

# ***LM18GC·LM56GC*** ***LM66TC***

Walk Behind Greens Mower  
Walk Behind Tee Mower

## Owner's Operating Manual

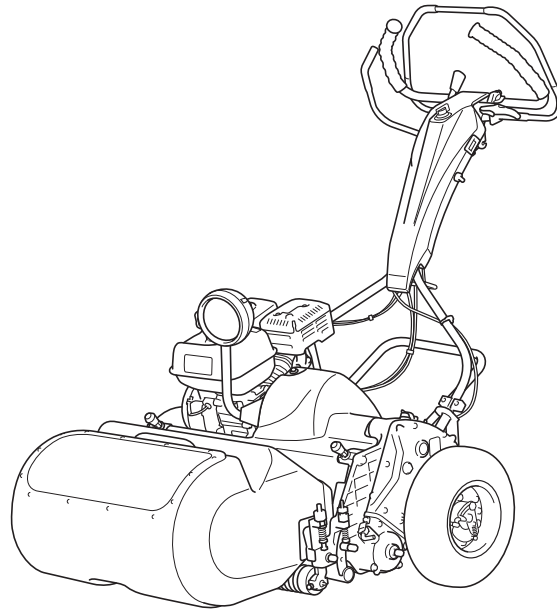

Serial No. LM18GC: 35165- · LM56GC: 36481-  
LM66TC: 35329-

"Required reading"  
Read this manual before using the machine.

---

**BARONESS**<sup>®</sup>  
Quality on Demand

Ver.2.8

# Regulations

---

## **USDA Forest Service Spark Arrester**

(For USA)

The engine of this machine is equipped with a spark arrester.

In some areas there are local, state, or federal regulations requiring that a spark arrester be used on the engine of this machine.

Thank you for purchasing the Baroness product. This manual describes the proper handling, adjustment, and inspection of your product. We hope you will use the product safely, and take advantage of its best performance.

## QR Code

A QR code label is affixed on the machine.

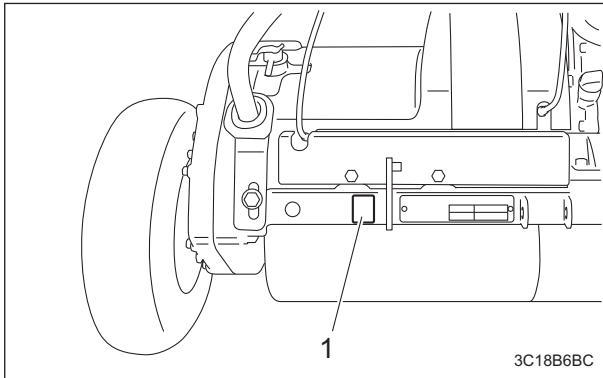

QR Code\_001

1	QR code label
---	---------------

Scan the QR code with your smartphone for easy access to Baroness Manual Reference Service where you can browse Owner's Operating Manual and Parts Catalog.  
 LM18GC: <https://doc.baroness-international.com/manuals/LM18GC>  
 LM18GC-0901Z0  
 QR code LM18GC



QR Code\_002

LM56GC: <https://doc.baroness-international.com/manuals/LM56GC>  
 LM56GC-0901Z0  
 QR code LM56GC



QR Code\_003

LM66TC: <https://doc.baroness-international.com/manuals/LM66TC>  
 LM66TC-0901Z0  
 QR code LM66TC



QR Code\_004

# Introduction

Read this manual carefully to ensure that you thoroughly understand how to properly operate and maintain the product, and to avoid causing injury to yourself or others.

The operator is responsible for operating the product properly and safely.

Maintenance service for this machine should be performed by a mechanic with expertise.

If you have any questions concerning maintenance or genuine parts, please contact a Baroness dealer or Kyoisha.





When making inquiries about your product, please specify the model and serial number.

When loaning or transferring the product, please also provide this manual together with the product.

Kyoisha Co., Ltd.

## Warning Symbols

This manual uses the following warning symbols for handling precautions that are important for your safety.

 <small>696cq5-001</small>	<p>Warning symbol</p>
<p>This symbol indicates the articles regarding “Danger,” “Warning,” or “Caution.” Those articles describe important safety precautions and so read them carefully to understand completely before operating the machine.</p> <p>Failure to adequately follow these safety precautions may cause an accident.</p>	
<p><b> Danger</b></p> <p>This symbol indicates that serious injury or death will occur if the warning is ignored.</p>	
<p><b> Warning</b></p> <p>This symbol indicates that serious injury or death may occur if the warning is ignored.</p>	
<p><b> Caution</b></p> <p>This symbol indicates that injury or damage to property may occur if the warning is ignored.</p>	
<p><b>Important</b></p> <p>This symbol indicates precautions on the mechanism of the machine.</p>	

## Precautionary Statement

 Caution

The information described in this manual is subject to change for improvement without prior notice.

When replacing parts, be sure to use genuine Baroness parts or parts designated by Kyoeshia.

Note that the Baroness product warranty may not apply to defects caused by the use of parts from other companies.

Prior to use, carefully read the following manuals to thoroughly understand the contents for safe and correct operation.

- Baroness Owner's Operating Manual
- The Engine's Owner's Manual

## Purpose

This machine is intended for cutting turf grass at golf courses.

Do not use this machine in any way other than its intended purpose, and do not modify the machine.

Operating this machine for other purposes and modifying it may be very dangerous and may cause damage to the machine.

# Introduction

---

<b>Safety</b> .....	<b>Page 1-1</b>	Storage .....	Page 6-25
Safe Operating Practices .....	Page 1-2	<b>Repair</b> .....	<b>Page 7-1</b>
<b>Disposal</b> .....	<b>Page 2-1</b>	Precautions for Repair .....	Page 7-2
Recycle and Waste Disposal .....	Page 2-2	Adjustment and Replacement .....	Page 7-2
<b>Product Overview</b> .....	<b>Page 3-1</b>	<b>Appended Table</b> .....	<b>Page 8-1</b>
Specifications .....	Page 3-2	Tightening Torques .....	Page 8-2
Names of Each Section .....	Page 3-9	Maintenance Schedule .....	Page 8-5
Regulation Decals .....	Page 3-9	List of Adjusted Values .....	Page 8-7
Safety Signs and Instruction Signs .....	Page 3-11	Troubleshooting Procedures of Aftercut Appearance .....	Page 8-8
Operation Decals .....	Page 3-13		
<b>Description of Functions</b> .....	<b>Page 4-1</b>		
Light Switch .....	Page 4-2		
Engine Switch .....	Page 4-2		
Throttle Lever .....	Page 4-2		
Throttle Lever .....	Page 4-2		
Brake Lever .....	Page 4-3		
Clutch Lock Lever .....	Page 4-3		
Main Clutch Lever .....	Page 4-3		
Traveling/Working Selector Lever .....	Page 4-4		
FOC (High/Low Clip) Selector Lever .....	Page 4-4		
Air Adjusting Plate .....	Page 4-5		
Engine Clutch Cover .....	Page 4-5		
Groomer Clutch Lever .....	Page 4-5		
IGCA (Independent Grass Catcher Arm) .....	Page 4-6		
Instruments .....	Page 4-8		
<b>Handling Instructions</b> .....	<b>Page 5-1</b>		
Preparation for Use .....	Page 5-2		
Inspection and Cleaning .....	Page 5-3		
Adjustment before Work .....	Page 5-8		
Start/Stop of Engine .....	Page 5-9		
Parking and Stopping .....	Page 5-11		
Move .....	Page 5-11		
Cutting Work .....	Page 5-12		
Transporting .....	Page 5-14		
<b>Maintenance</b> .....	<b>Page 6-1</b>		
Precautions for Maintenance .....	Page 6-2		
Position of Mower during Maintenance .....	Page 6-2		
Greasing .....	Page 6-2		
Lubrication .....	Page 6-4		
Adjustment and Replacement .....	Page 6-5		

# Contents

---



**Safe Operating Practices ..... Page 1-2**

Training ..... Page 1-2

Preparation ..... Page 1-2

Operation ..... Page 1-3

Maintenance ..... Page 1-4

Storage ..... Page 1-4

# Safety

Failure to adequately follow these safety precautions may cause an accident resulting in injury or death.

## Danger

This product is designed to ensure safe operation and has been tested and inspected thoroughly before shipment from the factory. The product is equipped with safety devices to prevent accidents.

However, whether the product demonstrates its original performance level depends on the manner in which it is operated and handled, as well as the manner in which it is managed on a daily basis.

Inappropriate use or management of the product may result in injury or death.

Observe the following safety instructions to ensure safe operation.

## Safe Operating Practices

### Training

1. Read this manual and other training material carefully.  
Be familiar with the controls, safety signs, and the proper use of the equipment.
2. If the operator or mechanic can not read the language used in this manual, it is the owner's responsibility to explain this material to them.
3. All operators and mechanics should seek and obtain professional and practical instruction.  
The owner is responsible for training the users.
4. Never allow people unfamiliar with these instructions to use or service the machine.  
Local regulations may restrict the age of the operator.
5. The owner/user can prevent and is responsible for accidents or injuries occurring to themselves, other people, or property.
6. Keep in mind that the owner, operator, and mechanic are responsible for accidents or hazards occurring to other people or their property.
7. You can find additional safety information where needed throughout this manual.
8. Determine the left and right sides of the machine from the normal operating position.

### Preparation

1. Evaluate the terrain to determine what accessories and attachments are needed to properly and safely perform the job.  
Only use accessories and attachments approved by the manufacturer.
2. While operating, always wear substantial footwear, long trousers, hard hat, safety glasses, mask, and ear protection.  
Long hair, loose clothing, or jewelry may get tangled in moving parts.  
Do not operate the equipment when barefoot or wearing open sandals.
3. Inspect the area where the equipment is to be used and remove all objects such as rocks, toys and wire which can be thrown by the machine.
4. Keep children out of the operating area and under the watchful care of a responsible adult other than the operator.
5. Exercise care in the handling of fuel.

## Warning

Fuel is highly flammable.  
Take the following precautions:

- [1] Store fuel in containers specifically designed for this purpose.
- [2] Add fuel before starting the engine.  
Never remove the cap of the fuel tank or add fuel while the engine is running or when the engine is hot.
- [3] Refuel outdoors only and do not smoke while refueling.
- [4] If fuel is spilled, do not attempt to start the engine but move the machine away from the area of spillage and avoid creating any source of ignition until petrol vapours have dissipated;
- [5] Replace all fuel tanks and container caps securely.
6. Check that operator's presence controls, safety switches and shields are attached and functioning properly.  
Do not operate unless they are functioning properly.
7. If the brake operation is faulty, be sure to adjust or repair them before operating the machine.

8. If the handlebar has noticeable play, be sure to adjust or repair them before operating the machine.
9. Replace faulty mufflers.

### Operation

1. Do not operate the machine under the influence of alcohol or drugs.
2. Do not operate the engine in a confined space where dangerous carbon monoxide fumes can collect.
3. Be sure all drives are in neutral and parking brake is engaged before starting engine.
4. Start the engine or switch on the motor carefully according to this manual and with feet well away from the cutting section.
5. Do not change the engine governor settings or overspeed the engine.  
Operating the engine at excessive speed may increase the hazard of personal injury.
6. Pay attention not to touch hot parts.
7. Never operate the machine with damaged guards, shields, or without safety protective devices in place.  
Be sure all interlocks are attached, adjusted properly, and functioning properly.
8. Keep hands and feet away from the rotating parts.
9. Never pick up or carry the machine in operation.
10. Never operate while people, especially children, or pets are nearby.
11. Only operate in good light, keeping away from holes and hidden hazards.
12. Do not operate the machine when there is the risk of lightning.
13. Walk, never run.
14. Do not stop or start suddenly.
15. Avoid operating the equipment in wet grass, where feasible.
16. Look behind and down before backing up to be sure of a clear path.
17. Slow down and use caution when making turns and crossing roads and sidewalks.
18. Use care when approaching blind corners, shrubs, trees, or other objects that may obscure vision.
19. Do not take your eyes off the road ahead.  
Do not operate the machine with no hands.
20. Always be sure of your footing on slopes.
21. Remember there is no such thing as a safe slope.  
Travel on grass slopes requires particular care.  
To guard against overturning, follow these instructions.
  - [1] Do not operate the machine on excessively steep slopes.
  - [2] Do not stop or start suddenly when going up or downhill.
  - [3] Engage clutch slowly, always keep machine in gear, especially when traveling downhill.
  - [4] Machine speeds should be kept low on slopes and during turns.
22. Use extra care while operating machine with a grass catcher or other attachments.  
They can affect the stability of the machine.
23. Disengage drive to the cutting section, when other than operating.
24. Do the following before leaving the operator's position.
  - [1] Stop on level ground.
  - [2] Disengage the all drives.
  - [3] Set the parking brake.
  - [4] Stop the engine.
25. Stop the engine in the following conditions.
  - [1] Before refuelling.
  - [2] Before removing the grass catcher.
  - [3] Before making height or depth adjustment unless adjustment can be made from the operator's position.
  - [4] Before clearing blockages.
  - [5] Before checking, cleaning or working on the machine.
  - [6] After striking a foreign object or if an abnormal vibration occurs.  
Inspect the machine for damage and make repairs before restarting and operating the equipment.
26. Reduce the throttle setting during engine run-out.
27. Do not direct discharge material toward anyone.  
Avoid discharging material against a wall or obstruction.  
Material may ricochet back toward the operator.

# Safety

---

28. Take care when loading or unloading the machine into a trailer or a truck.  
Load or unload the machine in a flat and safe place.  
Before loading or unloading, set the parking brake on the truck or trailer, stop the engine, and chock the wheels.  
When transporting the machine on a truck or a trailer, set the parking brake, stop the engine, and fasten the machine to the truck with a rope or other suitable restraining device that has sufficient strength.  
When using a running board, select one with sufficient strength, length, and width and that will not cause the machine to slip.
29. Close the fuel valve before transporting the machine.

## Maintenance

1. Never allow untrained personnel to service machine.
2. Implement the following work before adjusting, cleaning or repairing.
  - [1] Stop the machine on level ground.
  - [2] Disengage drive to the cutting section.
  - [3] Set the parking brake.
  - [4] Stop the engine.
  - [5] Disconnect spark plug wire.
  - [6] Wait for all movement to stop.
3. Allow the engine/muffler to cool before checking/maintenance.
4. To reduce the fire hazard, keep hot parts such as the engine and silencer/muffler, and fuel storage area free of grass, leaves, or excessive grease.  
Clean up oil or fuel spillage.
5. Appropriately manage and correctly use the tools necessary for servicing or adjusting the machine.
6. Use jack stands to support components when required.
7. Keep hands and feet away from moving parts.  
If possible, do not make adjustments with the engine running.
8. Make sure that parts such as wires are not touching each other and that their covers have not come off.
9. Keep all parts in good working condition and all hardware tightened.  
Replace all worn or damaged decals.

10. Keep all nuts, bolts and screws tight to be sure the equipment is in safe working condition.
11. Carefully release pressure from components with stored energy.
12. Use care when checking the cylinders/reels and bed knives.  
Wear gloves and use caution when servicing them.
13. Be careful during adjustment of the machine to prevent entrapment of the fingers between moving blades and fixed parts of the machine.
14. Check the grass catcher frequently for wear or deterioration.
15. If the fuel tank has to be drained, do this outdoors.

## Storage

1. Allow the engine to cool before storing in any enclosure.
2. Only cover the machine with a sheet after hot parts have sufficiently cooled down.
3. Never store the equipment with fuel in the tank inside a building where fumes may reach an open flame or spark.
4. If the engine is provided with a shut-off valve, shut off valve while storing or transporting.
5. Do not store fuel near flames.

**Recycle and Waste Disposal ..... Page 2-2**

About Recycle .....Page 2-2

About Waste Disposal ..... Page 2-2

# Disposal

---

## Recycle and Waste Disposal

### About Recycle

Recycling battery etc. is recommended for environmental conservation and economical use of resources.

It may be required by local laws.

### About Waste Disposal

Make sure that waste generated when servicing or repairing the machine is disposed of in accordance with local regulations. (e.g. waste oil, antifreeze, rubber products, and wires etc.)

**Specifications ..... Page 3-2**

- Specifications List ..... Page 3-2
- Sound Pressure Level ..... Page 3-8
- Sound Power Level ..... Page 3-8
- Vibration Level ..... Page 3-8

**Names of Each Section ..... Page 3-9**

**Regulation Decals ..... Page 3-9**

- Positions of Regulation Decals ..... Page 3-9
- Description of Regulation Decals ..... Page 3-9

**Safety Signs and Instruction Signs ... Page 3-11**

- About Safety Signs and Instruction  
Signs ..... Page 3-11
- Positions of Safety Decals and  
Instruction Decals ..... Page 3-11
- Description of Safety Decals and  
Instruction Decals ..... Page 3-11

**Operation Decals ..... Page 3-13**

- Positions of Operation Decals ..... Page 3-13
- Description of Operation Decals ..... Page 3-13

# Product Overview

## Specifications

### Specifications List

#### LM18GC

Model		LM18GC	
Name		Walk Behind Greens Mower	
Dimensions	Total length	with grass catcher	141 cm 55.51 in
	Total width	without travelling wheel	84 cm 33.07 in
	Total height	Steering handle	116 cm 45.67 in
Weight	Machine (empty fuel tank)		94 kg 207.23 lb
	Grass catcher *1		3.1 kg 6.83 lb
	Groomer *1		3.0 kg 6.61 lb
	Travelling wheel (for one machine) *1		6.9 kg 15.21 lb
Minimum turning radius		-	
Engine	Model		HONDA GX120
	Type		Gasoline air-cooled engine (OHV) four-stroke single-cylinder
	Total displacement		122 cm <sup>3</sup> (0.122 L) 7.44 cu.in.
	Maximum output		2.4 kW (3.3 PS)/3,600 rpm
	Rated output		2.1 kW (2.9 PS)/3,600 rpm
Fuel tank capacity		Gasoline 2.0 dm <sup>3</sup> (2.0 L)	Gasoline 0.53 U.S.gals
Fuel consumption		338 g/kW · h (rated output)	248.60 g/PS · h (rated output)
Engine oil capacity		0.56 dm <sup>3</sup> (0.56 L)	0.15 U.S.gals
Coolant volume		-	
Hydraulic tank capacity		-	
Transmission oil capacity		-	
Operating width (Mowing width)		45.7 cm	18 in
Operating height (Mowing height)		3.0 (3.0) - 29.0 mm[3.0 (3.0) - 27.0 mm] *2	0.118 (0.118) - 1.142 in[0.118 (0.118) - 1.063 in] *2
Number of Blades		11	
Drive	Traveling	Mechanical	
	Mowing	Mechanical	
Speed (HST)		-	
Speed (Mechanical)		4.7 km/h (@3,000 rpm)	2.92 mph (@3,000 rpm)
Efficiency		1,718 m <sup>2</sup> /h (4.7 km/h x mowing width x 0.8)	0.42 acres/hour (2.92 mph x mowing width x 0.8)
Maximum inclination for operation		-	
Tire size		4.10/3.50-6	
Tire pneumatic pressure		120 kPa (1.2 kgf/cm <sup>2</sup> )	17 psi
Battery		-	
Engine plug		NGK BPR4ES	



The factory default maximum engine rpm is 3,300 rpm.

\*1: Weight (Machine) includes \*1 parts.

\*2: The indicated lowest mowing height is for general application. It may be adjusted according to the state of green and the bed knife to be installed.

The value in the brackets [ ] is the mowing height of the machine equipped with a groomer.

The value in the brackets ( ) is the mowing height of the machine equipped with a standard bed knife.

# Product Overview

## LM56GC

Model		LM56GC	
Name		Walk Behind Greens Mower	
Dimensions	Total length	with grass catcher	141 cm 55.51 in
	Total width	without travelling wheel	94 cm 37.01 in
	Total height	Steering handle	116 cm 45.67 in
Weight	Machine (empty fuel tank)		102 kg 224.87 lb
	Grass catcher *1		3.3 kg 7.28 lb
	Groomer *1		3.6 kg 7.94 lb
	Travelling wheel (for one machine) *1		6.9 kg 15.21 lb
Minimum turning radius		-	
Engine	Model		HONDA GX120
	Type		Gasoline air-cooled engine (OHV) four-stroke single-cylinder
	Total displacement		122 cm <sup>3</sup> (0.122 L) 7.44 cu.in.
	Maximum output		2.4 kW (3.3 PS)/3,600 rpm
	Rated output		2.1 kW (2.9 PS)/3,600 rpm
Fuel tank capacity		Gasoline 2.0 dm <sup>3</sup> (2.0 L)	Gasoline 0.53 U.S.gals
Fuel consumption		338 g/kW · h (rated output)	248.60 g/PS · h (rated output)
Engine oil capacity		0.56 dm <sup>3</sup> (0.56 L)	0.15 U.S.gals
Coolant volume		-	
Hydraulic tank capacity		-	
Transmission oil capacity		-	
Operating width (Mowing width)		55.7 cm	22 in
Operating height (Mowing height)		3.0 (3.0) - 29.0 mm [3.0 (3.0) - 27.0 mm] *2	0.118 (0.118) - 1.142 in [0.118 (0.118) - 1.063 in] *2
Number of Blades		11	
Drive	Traveling	Mechanical	
	Mowing	Mechanical	
Speed (HST)		-	
Speed (Mechanical)		4.7 km/h (@3,000 rpm)	2.92 mph (@3,000 rpm)
Efficiency		2,094 m <sup>2</sup> /h (4.7 km/h x mowing width x 0.8)	0.51 acres/hour (2.92 mph x mowing width x 0.8)
Maximum inclination for operation		-	
Tire size		4.10/3.50-6	
Tire pneumatic pressure		120 kPa (1.2 kgf/cm <sup>2</sup> )	17 psi
Battery		-	
Engine plug		NGK BPR4ES	

The factory default maximum engine rpm is 3,300 rpm.

\*1: Weight (Machine) includes \*1 parts.

## Product Overview

---

\*2: The indicated lowest mowing height is for general application. It may be adjusted according to the state of green and the bed knife to be installed.

The value in the brackets [ ] is the mowing height of the machine equipped with a groomer.

The value in the brackets ( ) is the mowing height of the machine equipped with a standard bed knife.

# Product Overview

## LM66TC

Model		LM66TC	
Name		Walk Behind Tee Mower	
Dimensions	Total length	with grass catcher	141 cm 55.51 in
	Total width	without travelling wheel	103 cm 40.55 in
	Total height	Steering handle	116 cm 45.67 in
Weight	Machine (empty fuel tank)		107 kg 235.89 lb
	Grass catcher *1		3.6 kg 7.94 lb
	Groomer *1		4.0 kg 8.82 lb
	Travelling wheel (for one machine) *1		6.9 kg 15.21 lb
Minimum turning radius		-	
Engine	Model		HONDA GX120
	Type		Gasoline air-cooled engine (OHV) four-stroke single-cylinder
	Total displacement		122 cm <sup>3</sup> (0.122 L) 7.44 cu.in.
	Maximum output		2.4 kW (3.3 PS)/3,600 rpm
	Rated output		2.1 kW (2.9 PS)/3,600 rpm
Fuel tank capacity		Gasoline 2.0 dm <sup>3</sup> (2.0 L)	Gasoline 0.53 U.S.gals
Fuel consumption		338 g/kW · h (rated output)	248.60 g/PS · h (rated output)
Engine oil capacity		0.56 dm <sup>3</sup> (0.56 L)	0.15 U.S.gals
Coolant volume		-	
Hydraulic tank capacity		-	
Transmission oil capacity		-	
Operating width (Mowing width)		64.6 cm	26 in
Operating height (Mowing height)		4.5 (7.0) - 29.0 mm [4.5 (7.0) - 27.0 mm] *2	0.177 (0.276) - 1.142 in [0.177 (0.276) - 1.063 in] *2
Number of Blades		7, 9, 11	
Drive	Traveling		Mechanical
	Mowing		Mechanical
Speed (HST)		-	
Speed (Mechanical)		4.7 km/h (@3,000 rpm)	2.92 mph (@3,000 rpm)
Efficiency		2,429 m <sup>2</sup> /h (4.7 km/h x mowing width x 0.8)	0.60 acres/hour (2.92 mph x mowing width x 0.8)
Maximum inclination for operation		-	
Tire size		4.10/3.50-6	
Tire pneumatic pressure		120 kPa (1.2 kgf/cm <sup>2</sup> )	17 psi
Battery		-	
Engine plug		NGK BPR4ES	

The factory default maximum engine rpm is 3,300 rpm.

\*1: Weight (Machine) includes \*1 parts.

\*2: The indicated lowest mowing height is for general application. It may be adjusted according to the state of green and the bed knife to be installed.

The value in the brackets [ ] is the mowing height of the machine equipped with a groomer.

The value in the brackets ( ) is the mowing height of the machine equipped with a standard bed knife.

# Product Overview

---

## Sound Pressure Level

### LM18

#### ■ Sound Pressure Level

This machine was confirmed to have a continuous A-weighted sound pressure level of 87 dB by measuring identical machines in accordance with the procedure specified in ISO 5395-1:2013.

### LM56

#### ■ Sound Pressure Level

This machine was confirmed to have a continuous A-weighted sound pressure level of 87 dB by measuring identical machines in accordance with the procedure specified in ISO 5395-1:2013.

### LM66

#### ■ Sound Pressure Level

This machine was confirmed to have a continuous A-weighted sound pressure level of 87 dB by measuring identical machines in accordance with the procedure specified in ISO 5395-1:2013.

## Sound Power Level

### LM18

#### ■ Sound Power Level

This machine was confirmed to have a sound power level of 98 dB by measuring identical machines in accordance with the procedure specified in ISO5395-1:2013.

### LM56

#### ■ Sound Power Level

This machine was confirmed to have a sound power level of 98 dB by measuring identical machines in accordance with the procedure specified in ISO5395-1:2013.

### LM66

#### ■ Sound Power Level

This machine was confirmed to have a sound power level of 98 dB by measuring identical machines in accordance with the procedure specified in ISO5395-1:2013.

## Vibration Level

### LM18

#### ■ Hand-Arm Vibration

This machine was confirmed not to exceed a vibration level of 2.5 m/s<sup>2</sup> to hands and arms by measuring identical machines in accordance with the procedure specified in ISO 5395-1:2013.

### LM56

#### ■ Hand-Arm Vibration

This machine was confirmed not to exceed a vibration level of 2.5 m/s<sup>2</sup> to hands and arms by measuring identical machines in accordance with the procedure specified in ISO 5395-1:2013.

### LM66

#### ■ Hand-Arm Vibration

This machine was confirmed not to exceed a vibration level of 2.5 m/s<sup>2</sup> to hands and arms by measuring identical machines in accordance with the procedure specified in ISO 5395-1:2013.

**Names of Each Section**

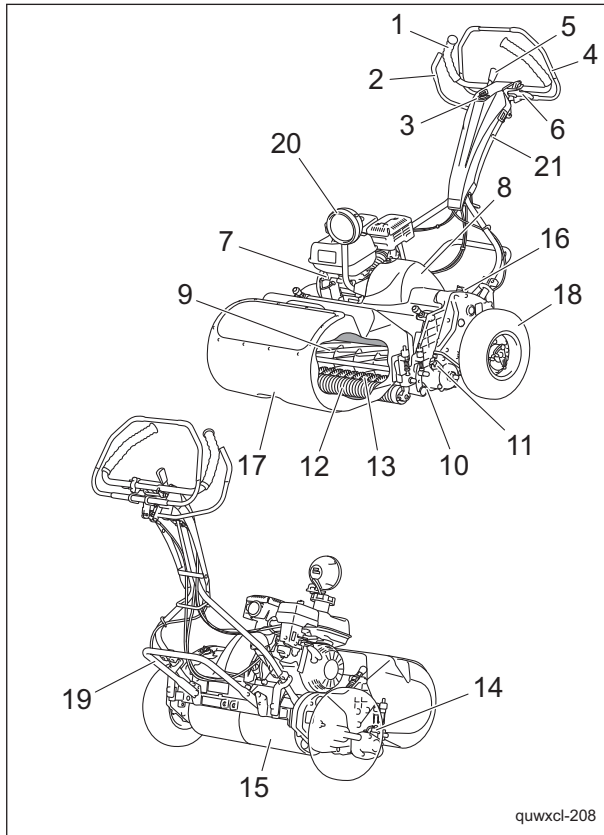

Names of Each Section\_001

1	Handle
2	Throttle lever
3	Engine switch
4	Main clutch lever
5	Clutch lock lever
6	Brake lever
7	Engine
8	Engine clutch cover
9	Reel cutter
10	Bed knife
11	FOC (High/Low Clip) selector lever
12	Front roller
13	Groomer
14	Groomer clutch lever
15	Drum
16	Traveling/ Working selector lever
17	Grass catcher
18	Traveling tires
19	Stand
20	Light
21	Light Switch

**Regulation Decals**

Positions of Regulation Decals

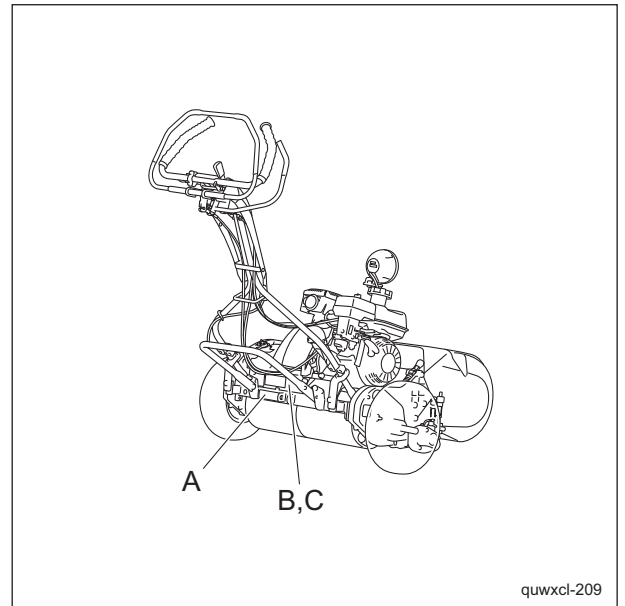

Positions of Regulation Decals\_001

A	Serial number plate
B	Spark arrester warning decal
C	California Proposition 65 decal (walk behind type)

Description of Regulation Decals

**Serial Number Plate**

The serial number plate indicates the model and serial number of the machine.

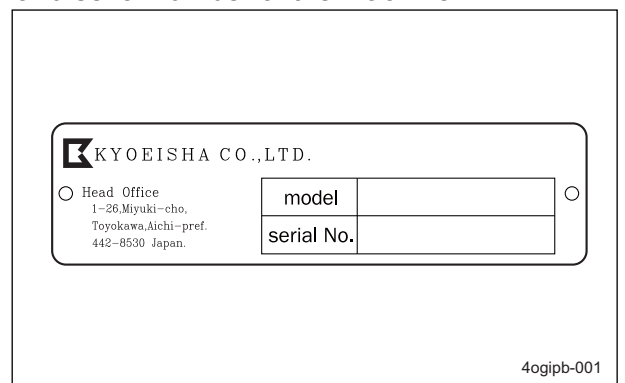

Serial Number Plate\_001

# Product Overview

---

## Spark Arrester Warning Decal

(For the State of California, USA)

Spark arrester warning decal describes the warning messages as required by California Public Resources Code.

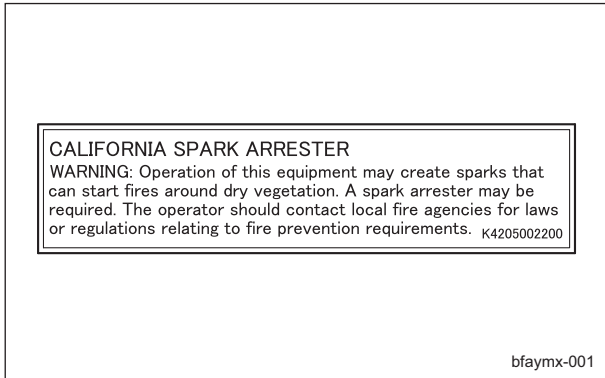

Spark Arrester Warning Decal\_001

## California Proposition 65 Decal (Walk Behind Type)

(For the State of California, USA)

California Proposition 65 Decal describes the warning messages as required by California Proposition 65.

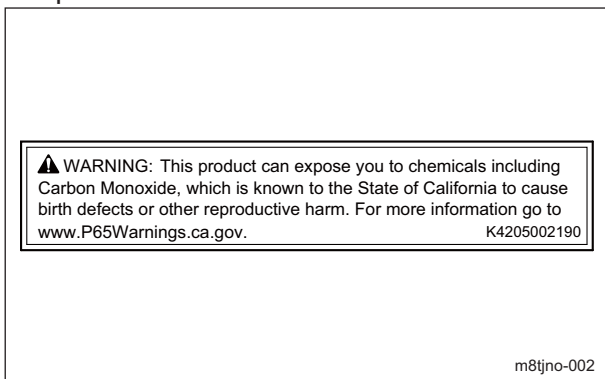

California Proposition 65 Decal (Walk Behind Type)\_001



## Safety Signs and Instruction Signs

### About Safety Signs and Instruction Signs

**Important**

Safety decals and instruction decals are attached to this product. Make sure that they are preserved in their entirety. If they are damaged, become dirty, or peel off, replace them with new ones.

Part numbers for decals that need to be replaced are listed in the parts catalog. Order them from a Baroness dealer or Kyoisha.

### Positions of Safety Decals and Instruction Decals

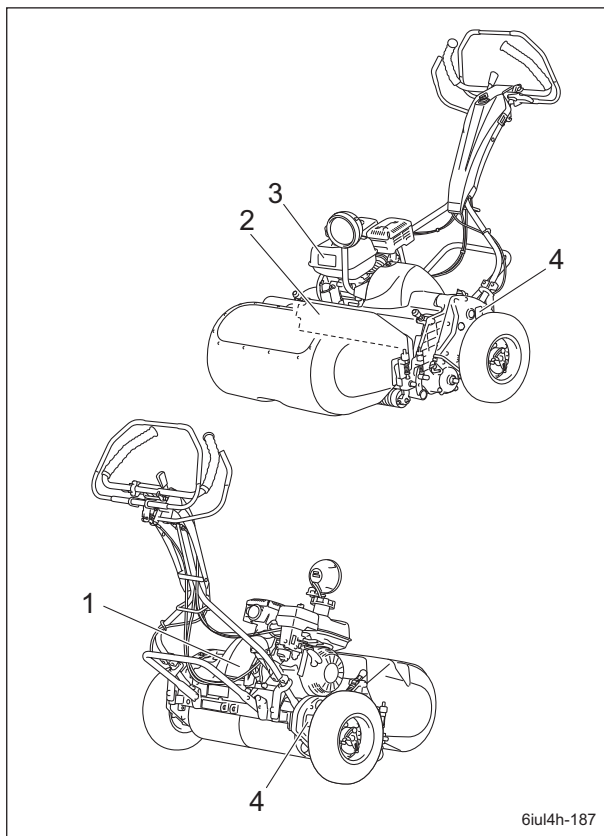

Positions of Safety Decals and Instruction Decals\_001

1	Safety instruction caution decal
2	Caution to mutilation decal
3	Caution to noise decal
4	Greasing 10HR decal

### Description of Safety Decals and Instruction Decals

#### Caution Safety Instruction Decal

K4205001590

DECAL, CAUTION SAFETY INSTRUCTION

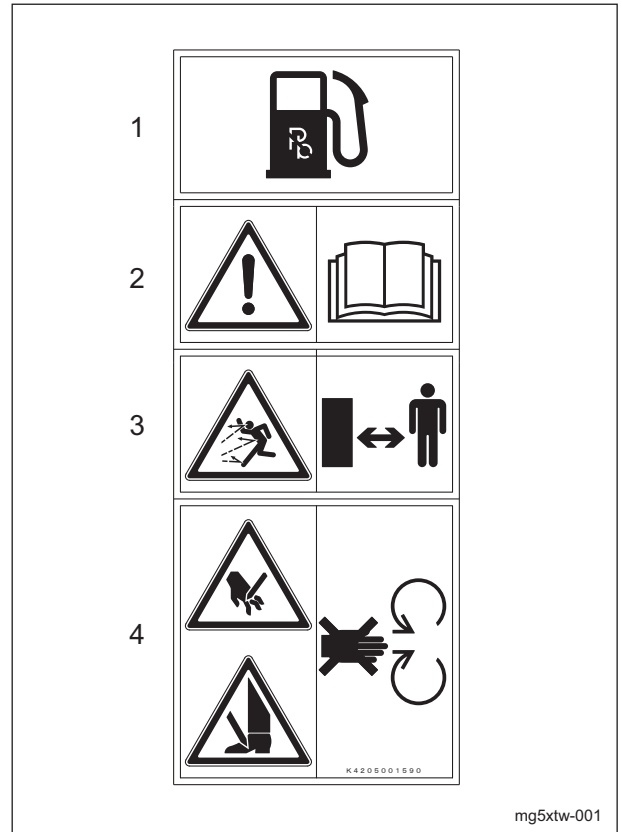

Caution Safety Instruction Decal\_001

1. Use lead-free gasoline.

2.



**Warning**

Read the Owner's Operating Manual.

3.

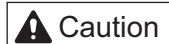

**Caution**

Flying objects - Be sure that people around the machine keep a safe distance away.

4.



**Warning**

May cut your hand or leg - When the blades are rotating, keep hands and feet away from moving parts.

# Product Overview

## Caution to Mutilation Decal

K4205001600  
DECAL, CAUTION TO MUTILATION

 Warning

May cut your hand or leg - Stop the cutter rotation and engine. Otherwise you may get injured.

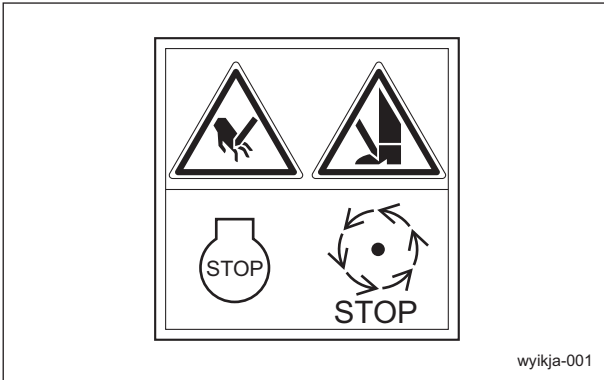

Caution to Mutilation Decal\_001

## Greasing Each 10-Hours Decal

K4209000370  
DECAL, GREASING EACH 10-HOURS  
Add grease every 10 hours.

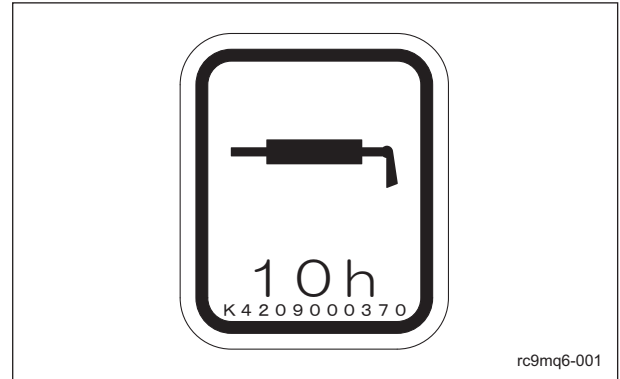

Greasing Each 10-Hours Decal\_001

## Caution to Noise Decal

K4205001330  
DECAL, CAUTION TO NOISE

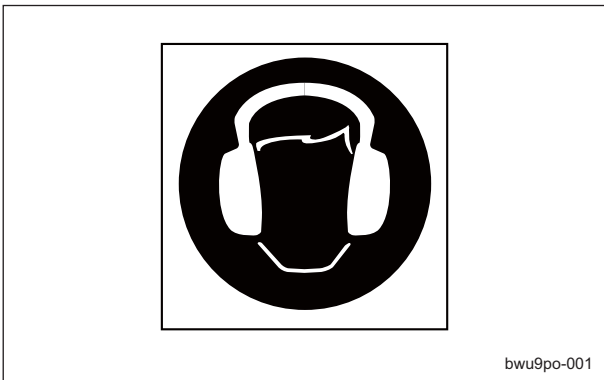

Caution to Noise Decal\_001

**Operation Decals**

Positions of Operation Decals

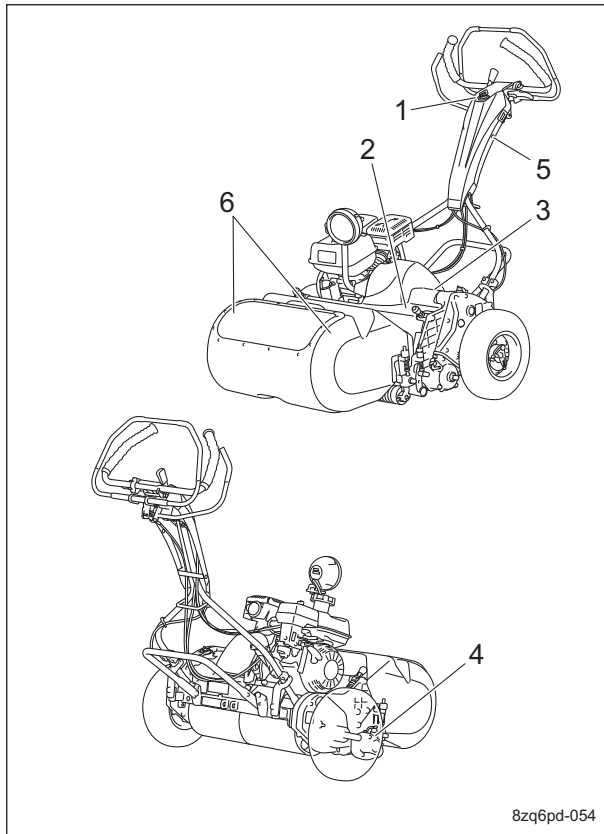

Positions of Operation Decals\_001

1	Decal, engine switch
2	Decal, clip selector lever
3	Decal, clutch
4	Decal, groomer indication
5	Decal, light switch
6	Sticker, alignment 10300

Description of Operation Decals

Engine Switch Mark

-  
**ENGINE SWITCH MARK**  
 It illustrates the positions of the engine switch.

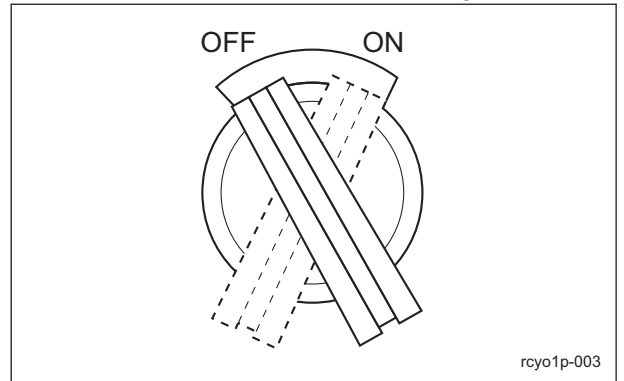

Engine Switch Mark\_001

High / Low Selector Lever Decal

K4203001320  
**STICKER, HIGH / LOW SELECTOR**  
 A: It illustrates High / Low clip of the reel clip of the reel cutter rotation speed.  
 B: It illustrates the positions of the air adjusting plate.

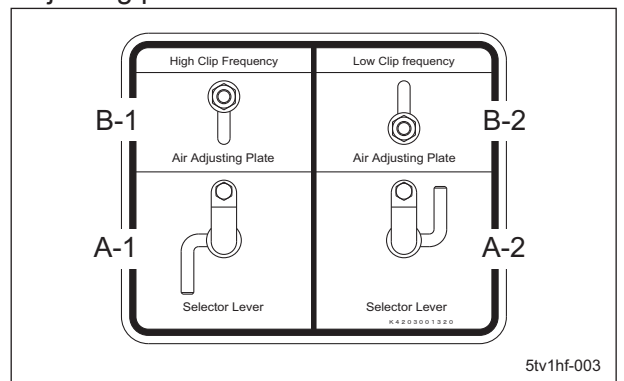

High / Low Selector Lever Decal\_001

A-1	High clip
A-2	Low clip
B-1	Close
B-2	Away

# Product Overview

## Clutch Decal

K4203001110  
 STICKER, CLUTCH  
 This indicates operating positions (traveling/working) for the reel cutter (cutting cylinder) and drum.

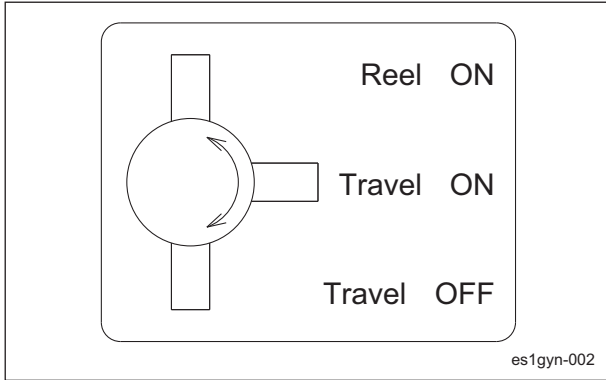

Clutch Decal\_001

## Light Switch Mark

Note:  
 Depending on the specifications, this function may not be available.  
 K4203001610  
 DECAL, LIGHT SWITCH  
 It illustrates ON/OFF of the light.

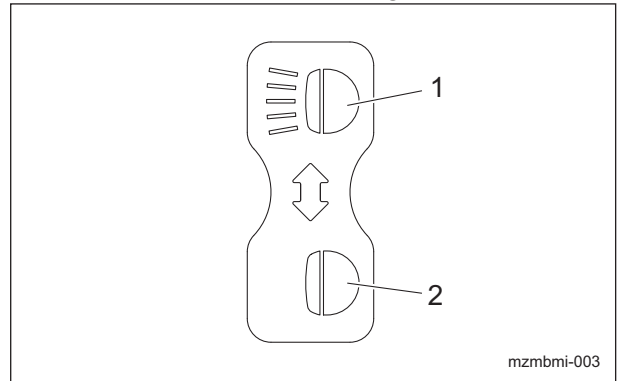

Light Switch Mark\_001

1	ON
2	OFF

## Groomer Indication Mark

Note:  
 Depending on the specifications, this function may not be available.  
 K4203001120  
 DECAL, GROOMER INDICATION  
 It illustrates the changeover of rotational direction of the groomer.

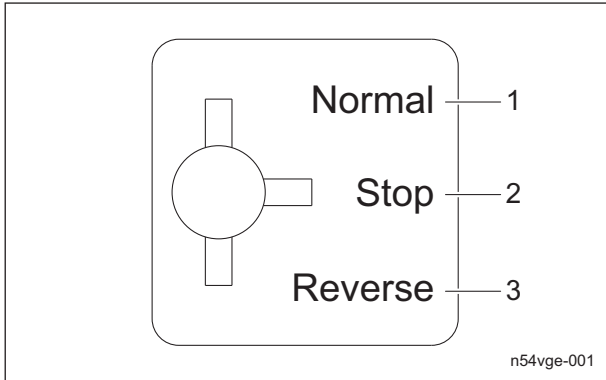

Groomer Indication Mark\_001

1	Normal rotation
2	Stop
3	Reverse rotation

## Red Alignment Mark 10300

Note:  
 Depending on the specifications, this function may not be available.  
 K4209001230  
 DECAL, ALIGNMENT 10300 (SET OF 2PCS)  
 Affix the decals in indicative positions on the grass catcher for operational support.

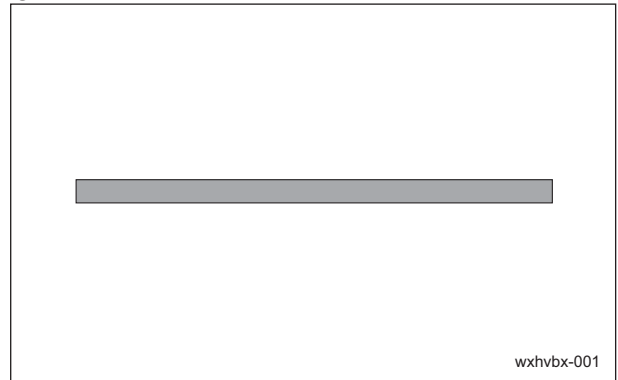

Red Alignment Mark 10300\_001

# Description of Functions

---

<b>Light Switch</b> .....	<b>Page 4-2</b>
<b>Engine Switch</b> .....	<b>Page 4-2</b>
<b>Throttle Lever</b> .....	<b>Page 4-2</b>
<b>Throttle Lever</b> .....	<b>Page 4-2</b>
<b>Brake Lever</b> .....	<b>Page 4-3</b>
<b>Clutch Lock Lever</b> .....	<b>Page 4-3</b>
<b>Main Clutch Lever</b> .....	<b>Page 4-3</b>
<b>Traveling/Working Selector Lever</b> .....	<b>Page 4-4</b>
<b>FOC (High/Low Clip) Selector Lever</b> ....	<b>Page 4-4</b>
<b>Air Adjusting Plate</b> .....	<b>Page 4-5</b>
<b>Engine Clutch Cover</b> .....	<b>Page 4-5</b>
<b>Groomer Clutch Lever</b> .....	<b>Page 4-5</b>
<b>IGCA (Independent Grass Catcher Arm)</b> .....	<b>Page 4-6</b>
<b>Instruments</b> .....	<b>Page 4-8</b>
Hour Meter .....	Page 4-8

# Description of Functions

## Light Switch

**Note:**  
Depending on the specifications, this function may not be available.  
The light switch is located in the handle panel. Flip up the switch to turn on the light, and down to turn off.

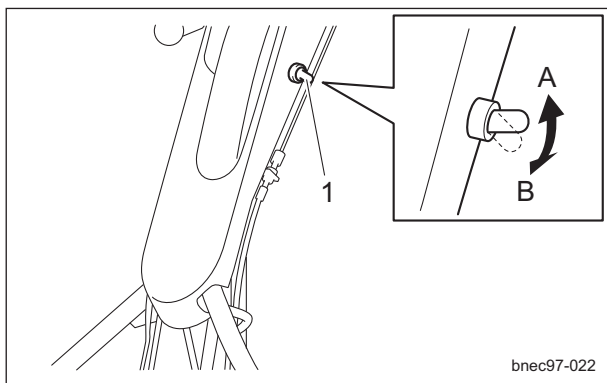

Light Switch\_001

1	Light switch
A	ON
B	OFF

## Engine Switch

The engine switch is located in the handle. To start the engine, set the engine switch to the "ON" position, and to stop it, set to the "OFF" position.

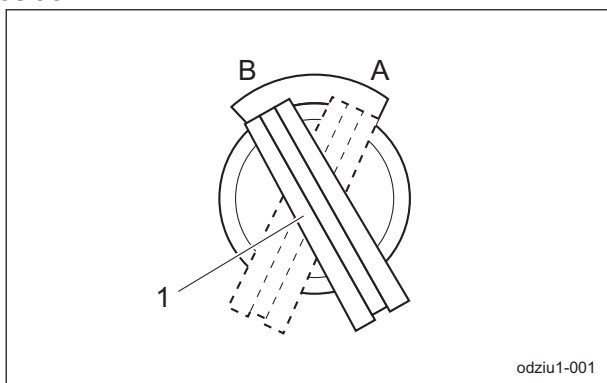

Engine Switch\_001

1	Engine switch
A	ON
B	OFF

## Throttle Lever

**Note:**  
Depending on the specifications, this function may not be available.  
The throttle lever is located in the handle and enables you to adjust the engine rpm. Grip the throttle lever tightly to move it toward "High speed" position for increasing the engine rpm, and loosen grip to move it toward "Low speed" position for decreasing the rpm.

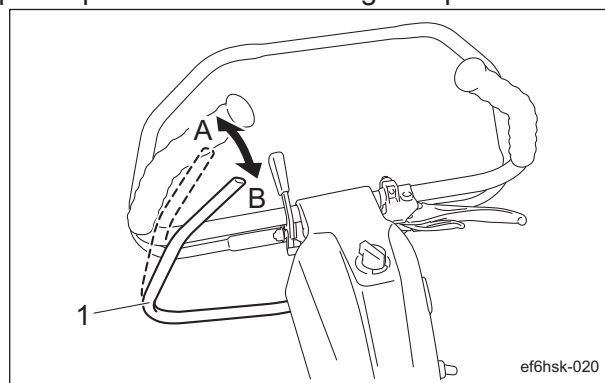

Throttle Lever\_001

1	Throttle lever
A	High speed
B	Low speed

## Throttle Lever

**Note:**  
Depending on the specifications, this function may not be available.  
The throttle lever is located in the handle and enables you to adjust the engine rpm. Move the throttle knob toward the "High speed" position to increase the engine rpm, and toward the "Low speed" position to reduce the rpm.

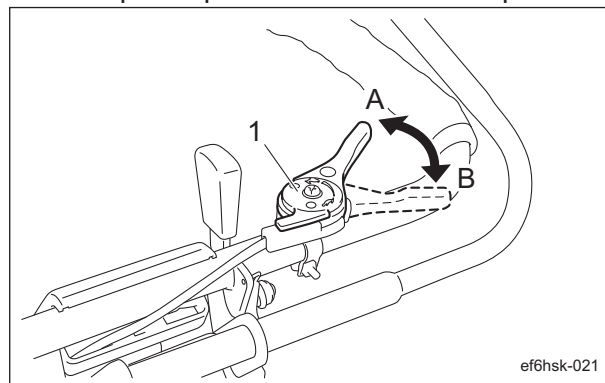

Throttle Lever\_001

1	Throttle lever
A	High speed
B	Low speed

# Description of Functions

## Brake Lever

**Caution**

Avoid quick operation.  
Carefully and slowly operate the machine.

The brake lever is located in the handle.  
Grip the brake lever to activate braking and the travel of the machine is stopped.  
Grip the lock lever while gripping the brake lever to lock the brake lever with braking applied.  
Grip the locked brake lever to release locking.  
Note:  
Lock the brake lever to apply Parking Brake.

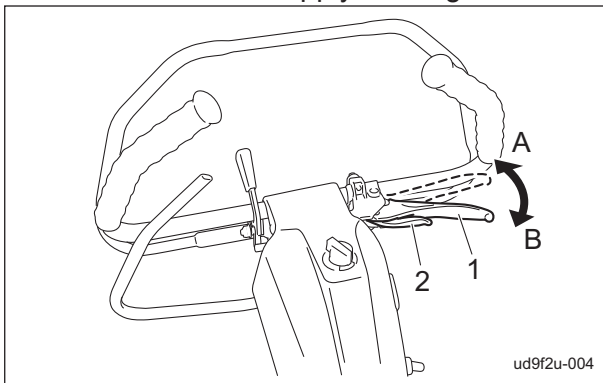

Brake Lever\_001

1	Brake lever
2	Lock lever
A	Lock
B	Unlock

## Clutch Lock Lever

The clutch lock lever is located in the handle.

**Important**

While the main clutch is in the "OFF" position, the safety lock is activated.

Grip the main clutch lever while tilting the clutch lock lever to "Unlock" side to unlock the safety lock.

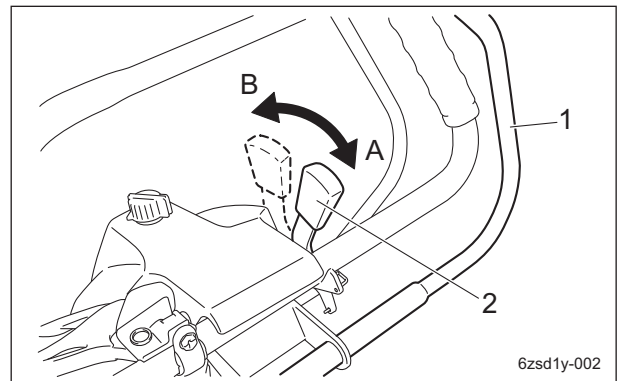

Clutch Lock Lever\_001

1	Main clutch lever
2	Clutch lock lever
A	Lock
B	Unlock

## Main Clutch Lever

**Caution**

Avoid quick operation.  
Carefully and slowly operate the machine.

**Important**

The main clutch is not activated unless the safety lock released.

The main clutch lever is located in the handle.  
Unlock the safety lock and then grip the main clutch lever to traveling forward with rotating the reel cutter.  
Release the main clutch lever from the hands to stop the machine traveling and the reel cutter rotating.

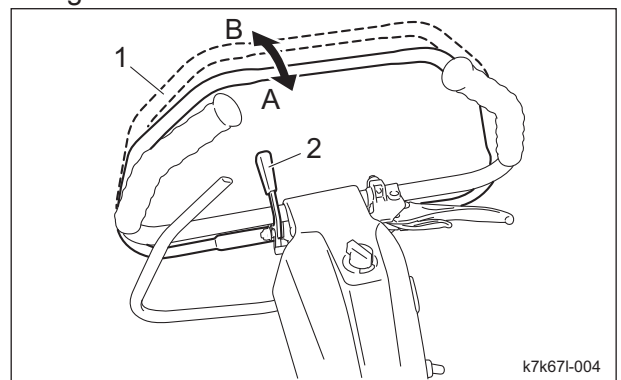

Main Clutch Lever\_001

1	Main clutch lever
2	Clutch lock lever
A	ON
B	OFF

# Description of Functions

## Traveling/Working Selector Lever

**Caution**

This lever should be operated while the main clutch lever is set to the disengaged position, and adjusted to the position suitable for your work.

The traveling/working selector lever is located on top of the left frame and has three positions. When the lever is set to the "Reel ON" position, the drum and reel cutter (cutting cylinder) operate and cutting is performed. When the lever is set to the "Travel ON" position, only the drum operates and the machine travels. When the lever is set to the "Travel OFF" position, both the drum and reel cutter (cutting cylinder) are not driven.

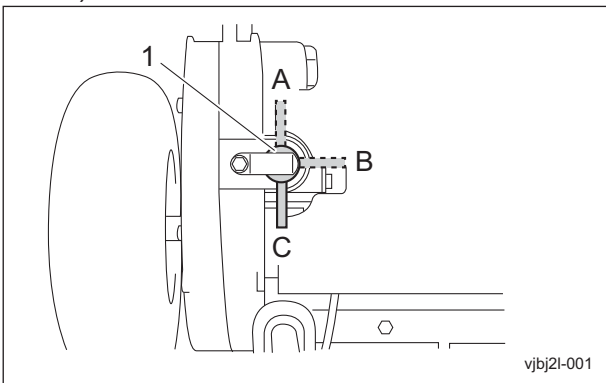

Traveling/Working Selector Lever\_001

1	Traveling/Working selector lever
A	Reel ON
B	Travel ON
C	Travel OFF

This is suitable for the work in good turf condition.

When the lever is set to the "Low clip" position, the reel cutter (cutting cylinder) rotates slower compared to the "High clip" position, and the clip pitch becomes longer.

This is suitable for the work when the turf condition is not so good.

When the lever is set to the "Stop" position, the drive transmission for the reel rotation gear is disengaged.

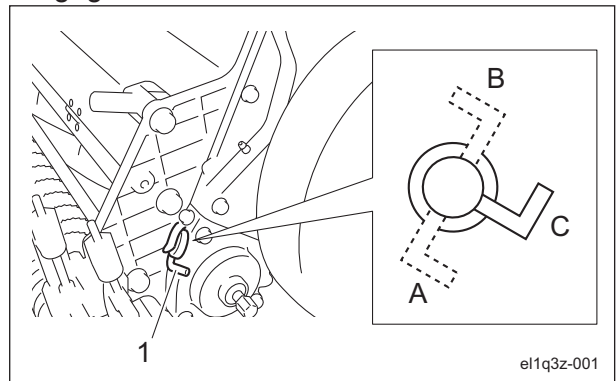

FOC (High/Low Clip) Selector Lever\_001

1	FOC (high/low clip) selector lever
A	High clip
B	Low clip
C	Stop

## FOC (High/Low Clip) Selector Lever

**Caution**

This lever should be operated while the main clutch lever is set to the disengaged position, and adjusted to the position suitable for your work.

The FOC (high/low clip) selector lever is located on the left frame and has three positions. When the lever is set to the "High clip" position, the reel cutter (cutting cylinders) rotates faster, and the clip pitch (cutting interval) becomes shorter.



# Description of Functions

## Air Adjusting Plate

**Caution**

The air adjusting plate should be operated while the engine rotation is stopped, and adjusted to the position suitable for your work.

The air adjusting plate is attached on the reel cover.

The dispersing angle of clippings can be adjusted by changing the position of the air adjusting plate.

Adjust it according to the grass condition and the reel rotation (high/low speed).

The air adjusting plate can be moved closer to the reel cutter when the grass condition is "dry" or the reel rotation is "high speed."

The air adjusting plate can be moved away from the reel cutter when the grass condition is "wet" or the reel rotation is "low speed."

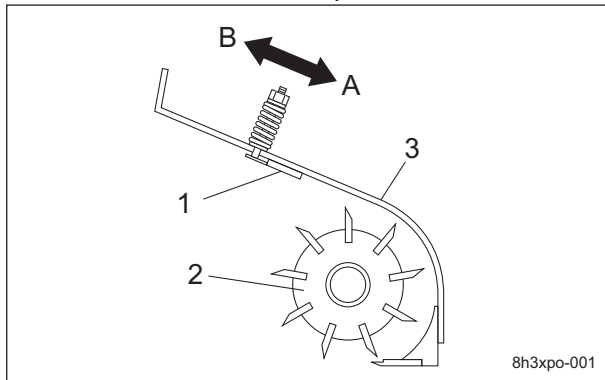

Air Adjusting Plate\_001

1	Air Adjusting Plate
2	Reel cutter
3	Reel cover
A	Close
B	Away

## Engine Clutch Cover

The engine clutch cover is located on the left side of the engine and covers the engine clutch. Open or close the engine clutch cover by removing or installing the lock bolt.

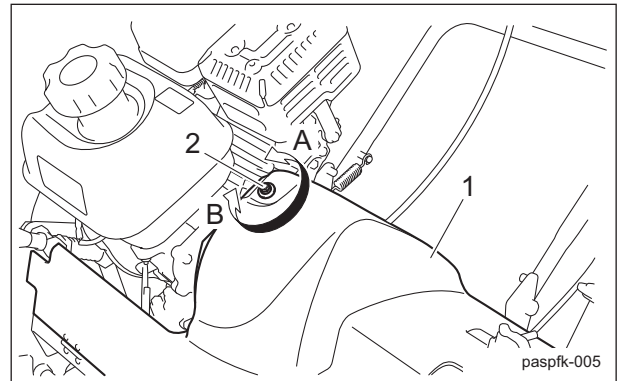

Engine Clutch Cover\_001

1	Engine clutch cover
2	Lock bolt
A	Loosen
B	Tighten

## Groomer Clutch Lever

Note:

Depending on the specifications, this function may not be available.

**Caution**

This lever should be operated while the main clutch lever is set to the disengaged position, and adjusted to the position suitable for your work.

The groomer clutch lever is located on the upper side of the right frame and has three positions. When the lever is set to the "Normal" position, the groomer rotates in the same direction as the reel cutter (cutting cylinder).

When the lever is set to the "Reverse" position, the groomer rotates in the opposite direction as the reel cutter (cutting cylinder).

When the lever is set to the "Stop" position, the groomer will not rotate.

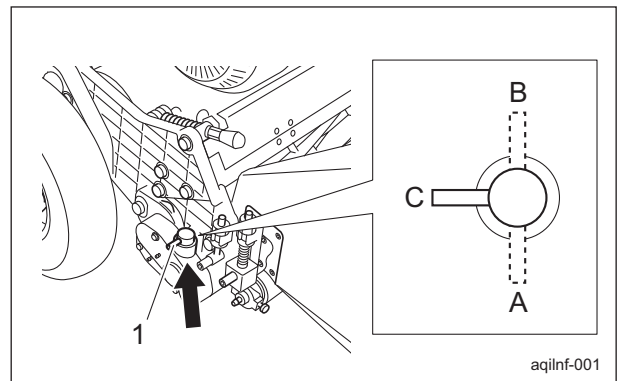

Groomer Clutch Lever\_001

# Description of Functions

1	Groomer clutch lever
A	Normal
B	Reverse
C	Stop

## IGCA (Independent Grass Catcher Arm)

**Note:**

Depending on the specifications, this function may not be available.

(IGCA can be installed onto the LM18GC/ LM56GC.)

IGCA is located above the cutting section. The IGCA is a mechanism that prevents the mowing attitude of the cutting section from changing, even when there is an increase in the volume of clippings entering the grass catcher. It eliminates as much as possible the transfer of rough handle movements causing changes in the cutting section attitude.

Since the cutting section is stabilized while the lawn is mowed, even if the handle is treated roughly, the cutting height does not change from the start of mowing the green to the end.

Stable lawn mowing work can be performed regardless of the operator's skill level and machine proficiency level, enabling all greens to be mowed at a uniform cutting height.

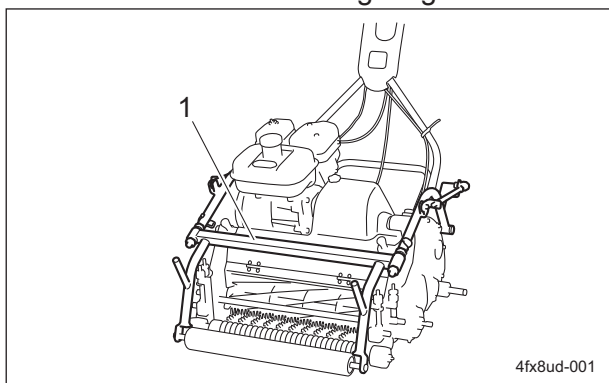

IGCA (Independent Grass Catcher Arm)\_001

1	IGCA
---	------

**Issue 1:**

The cutting height fluctuates due to the up-and-down movements of the cutting section caused by the weight of the grass catcher.

**Solution:**

The cutting section and grass catcher operate independently.

Therefore, the mowing attitude of the cutting section is not affected, even when the grass catcher becomes heavier from the added weight of grass, thatch, sand, etc.

The operator can mow at a uniform cutting height from the start of mowing the green to the end.

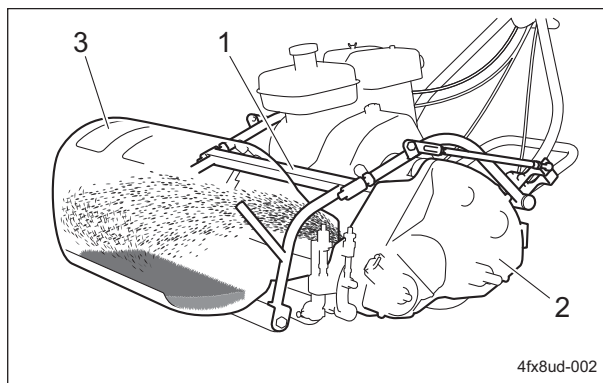

IGCA (Independent Grass Catcher Arm)\_002

1	IGCA
2	Cutting section
3	Grass catcher

# Description of Functions

**Issue 2:**

The cutting height is uneven due to the up-and-down movements of the cutting section caused by the operator's handle movements.

**Solution:**

The grass catcher and handle are linked, eliminating as much as possible the transfer of rough handle movements causing changes in the cutting section attitude. By adjusting the link rods, the handle can remain centered in the handle adjuster, and uniform cutting section contact pressure can be achieved.

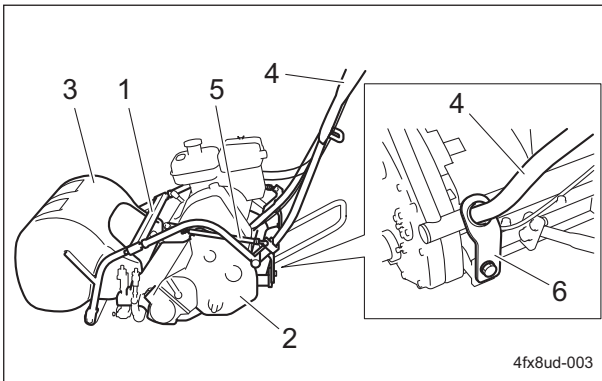

IGCA (Independent Grass Catcher Arm)\_003

1	IGCA
2	Cutting section
3	Grass catcher
4	Handle
5	Link rod
6	Handle adjuster

**Effect 1:**

Regardless of skill level, any operator can mow at a uniform cutting height, as long as the handle can be adjusted within the range of the hole in the handle adjuster.

This is effective when accelerating very quickly or mowing undulations.

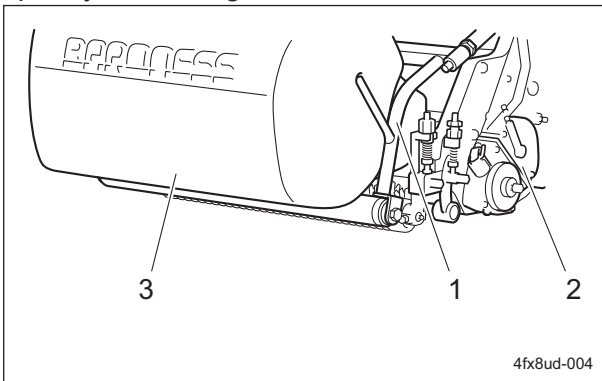

IGCA (Independent Grass Catcher Arm)\_004

1	IGCA
2	Cutting section
3	Grass catcher

**Effect 2:**

Since the load of the grass catcher does not affect the front roller, it is possible to reduce sinking (gouging or digging) caused by the front roller touching the ground when entering the green.

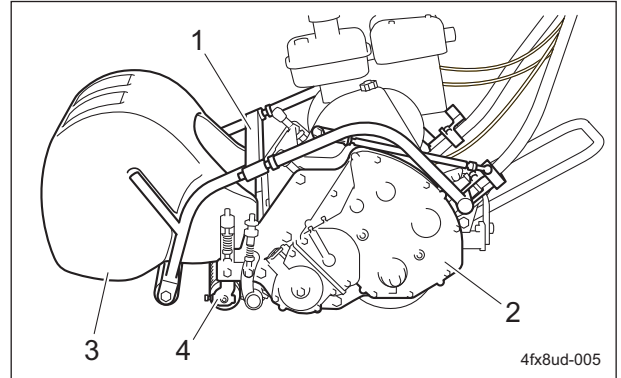

IGCA (Independent Grass Catcher Arm)\_005

1	IGCA
2	Cutting section
3	Grass catcher
4	Front roller

# Description of Functions

---

## Instruments

### Hour Meter

**Important**

The battery of this hour meter can not be replaced.  
If the battery power is burned out, replace the hour meter with a new one.

The hour meter indicates the accumulated operation time of the engine.  
The accumulated time can not be manually reset.  
When the accumulated time exceeds 99999 hours, the display automatically shows zero for restart.

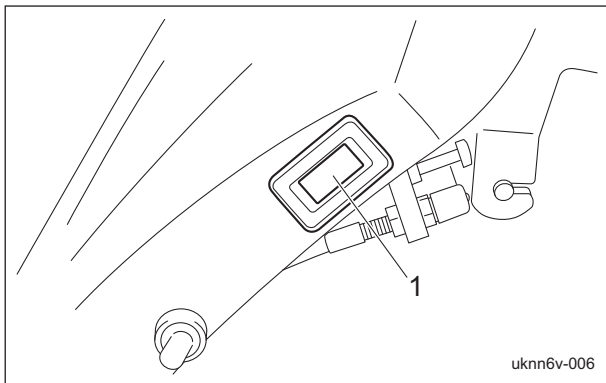

Hour Meter\_001

1	Hour meter
---	------------

# Handling Instructions

<b>Preparation for Use</b> .....	<b>Page 5-2</b>	Removing/Installing Grass Catcher .....	Page 5-13
Installing The Handle .....	Page 5-2	<b>Transporting</b> .....	<b>Page 5-14</b>
Connection of Engine Switch Cord .....	Page 5-2	Transporting Procedure .....	Page 5-14
Installing The Stand .....	Page 5-2		
Confirmation of The Operation .....	Page 5-3		
<b>Inspection and Cleaning</b> .....	<b>Page 5-3</b>		
Reel Cutter (Cutting Cylinder) and Bed Knife (Bottom Blade) .....	Page 5-3		
Cover .....	Page 5-3		
Air Cleaner .....	Page 5-3		
Roller .....	Page 5-4		
Drum .....	Page 5-5		
Tire .....	Page 5-5		
Brake .....	Page 5-5		
Clutch .....	Page 5-5		
Wire .....	Page 5-5		
Electrical Wiring .....	Page 5-5		
Around The Engine .....	Page 5-5		
Engine Oil .....	Page 5-6		
Fuel .....	Page 5-7		
Fuel Strainer .....	Page 5-7		
Liquid Leakage .....	Page 5-8		
Bolts and Nuts .....	Page 5-8		
Grass Catcher .....	Page 5-8		
<b>Adjustment before Work</b> .....	<b>Page 5-8</b>		
Adjustment of Handle Position .....	Page 5-8		
<b>Start/Stop of Engine</b> .....	<b>Page 5-9</b>		
Procedure to Start Engine .....	Page 5-9		
Procedure to Stop Engine .....	Page 5-10		
<b>Parking and Stopping</b> .....	<b>Page 5-11</b>		
Leaving The Machine .....	Page 5-11		
<b>Move</b> .....	<b>Page 5-11</b>		
Traveling Procedure .....	Page 5-11		
<b>Cutting Work</b> .....	<b>Page 5-12</b>		
Cutting Work .....	Page 5-12		
Removing/Installing Traveling Tires ....	Page 5-12		

# Handling Instructions

## Preparation for Use

### Installing The Handle

1. Put the handle pin on the left frame into the hole at the left-side lower edge of the handle.
2. While pressing the right-side lower edge of the handle inward, put the handle pin of the right frame into the hole.
3. Secure the lower edges (slotted section of the handle adjusters) of the right and left sides of the handle to the rear frame stay from the back with the bolts, conical spring washers, and washers.

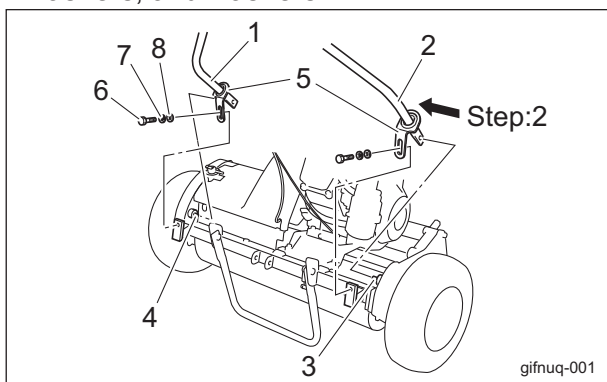

Installing The Handle\_001

1	Left-side lower edge of handle
2	Right-side lower edge of handle
3	Handle pin (Right frame)
4	Handle pin (Left frame)
5	Handle adjuster
6	Bolt
7	Conical spring washer
8	Washer

### Connection of Engine Switch Cord

#### Important

When the connection of the engine switch cord is incomplete, the engine will not stop even if the engine switch is operated. Check that the cord is correctly connected.

When assembling the handle, check the connection of the engine switch cord. There are two connections - plug and crimp terminal.

1. The plug is connected to the plug connected to the engine.

2. The crimp terminal is secured to the engine crankcase with a hexagon bolt.

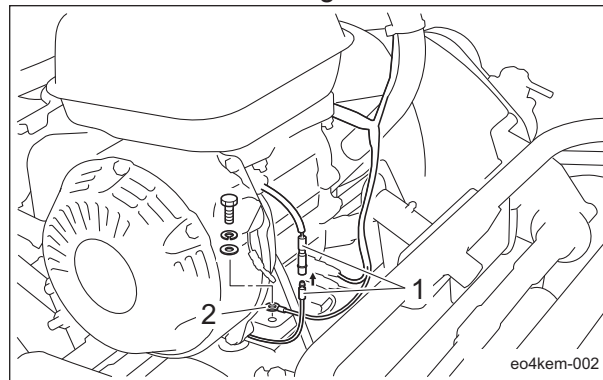

Connection of Engine Switch Cord\_001

1	Plug
2	Crimp terminal

### Installing The Stand

1. With the inside projection side set to the right, temporarily secure the left side of the stand to the frame with the bolt, washer (inside), and nut (outside).
2. Put the spring on the projection of the frame and the projection at the right edge of the stand.

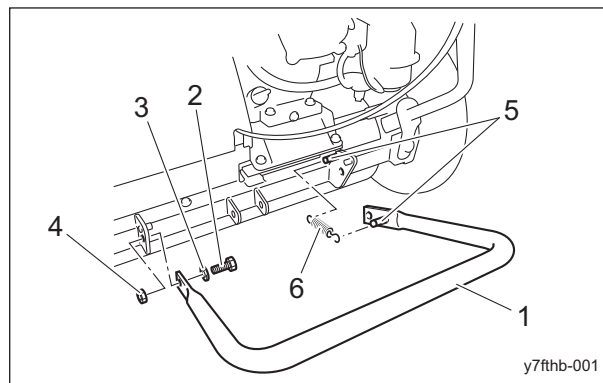

Installing The Stand\_001

1	Stand
2	Bolt
3	Washer
4	Nut
5	Projection
6	Spring

3. While pulling the right side of the stand backward, make alignment with the hole in the frame, and secure the stand with the bolt, washer (inside), and nut (outside).

# Handling Instructions

4. Tighten the bolt, washer, and nut at the left side of the stand that were temporarily secured.

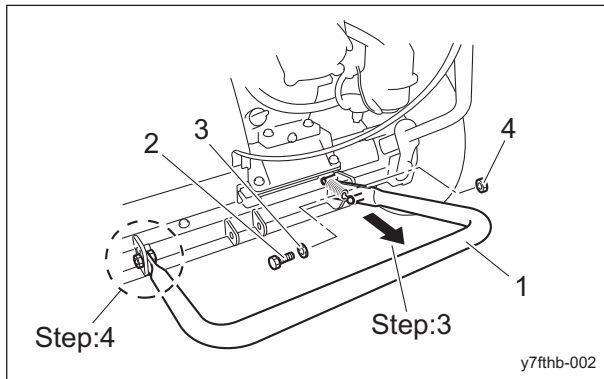

Installing The Stand\_002

1	Stand
2	Bolt
3	Washer
4	Nut

## Confirmation of The Operation

1. Check that the brake operates completely.
2. Check that the engine clutch operates completely.
3. If necessary, make adjustment.

## Inspection and Cleaning

Inspect and clean the machine with the goals of the followings.

- Accident prevention
- Failure prevention
- Performance retention

Make efforts for early detection of the machine failure and prevention of the sudden occurrence of trouble.

Perform maintenance and repair works immediately if any abnormality is found in the machine.

### Reel Cutter (Cutting Cylinder) and Bed Knife (Bottom Blade)

Inspection of Reel Cutter (Cutting Cylinder) and Bed Knife (Bottom Blade)

#### ⚠ Caution

Wear gloves when touching edged tools to avoid cutting your hands.

1. Check to see whether or not the edge of the reel cutter (cutting cylinder) and the bed knife (bottom blade) are too blunt to cut.

2. Make sure that the reel cutter (cutting cylinder) and the bed knife (bottom blade) are not cracked.
3. Check to see how much the reel cutter (cutting cylinder) and the bed knife (bottom blade) are worn.
4. Make sure that the reel cutter (cutting cylinder) and the bed knife (bottom blade) have not changed color due to heat from grinding.
5. Check to see whether or not the second edge face (relief) remains at the point of reel cutter (cutting cylinder).
6. Make sure that the welding between the reel cutter (cutting cylinder) and the disc has not come off.

## Cover

### Inspection of Covers

#### ⚠ Warning

If you have removed the covers during inspection, be sure to securely install them in their original positions. If a cover remains removed, the operator may come into contact with rotating parts or belts and foreign objects may fly off, possibly resulting in injuries.

1. Make sure that there is no wear or deterioration of the reel cover and all other covers.
2. Make sure that there is no damage to the reel cover and all other covers.
3. Make sure that there is no interference with moving parts due to deformation of the reel cover and all other covers.
4. Make sure that the reel cover and all other covers are installed in their appropriate positions.

## Air Cleaner

### Inspection of Air Cleaner

The air cleaner is a component that removes dirt from the intake air to prevent wear of the cylinder liners and piston rings so that the engine will always operate smoothly. A contaminated air cleaner element may cause malfunction of the engine.

1. Make sure that there is no damage to the air cleaner.

# Handling Instructions

2. Make sure that the air cleaner element is not contaminated.

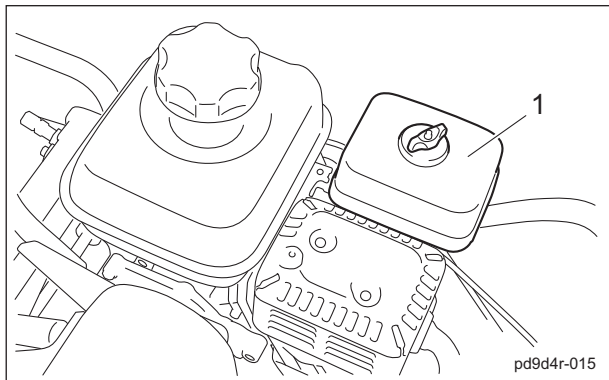

Inspection of Air Cleaner\_001

1	Air cleaner
---	-------------

## Cleaning of Air Cleaner Element

A contaminated air cleaner elements may cause malfunction of the engine. To maximize the life of the engine, clean the air cleaner properly.

1. Remove the wing screw, and then remove the cover.
2. Remove the screw, and then remove the air cleaner elements.
3. Remove the urethane element from the paper element.

### Important

When cleaning the paper element, do not use petroleum solvents.

### Important

Replace the air cleaner elements when it gets damaged or dirty.

4. Clean the urethane element with a solvent, such as a hardly flammable kerosene, and then soak it in the engine oil and wring out.
5. Remove dirt and dust from the paper element with blowing air or patting.
6. Assemble the paper and urethane elements.
7. Attach the air cleaner elements with the screw.

8. Set the cover, and then secure it firmly with the wing screw.

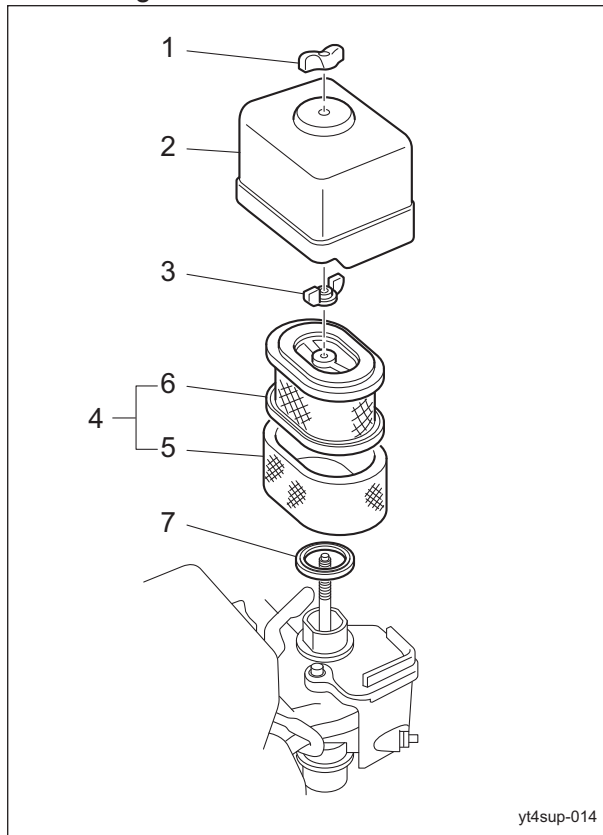

Cleaning of Air Cleaner Element\_001

1	Wing screw
2	Cover
3	Screw
4	Air cleaner element
5	Urethane element
6	Paper element
7	Gasket

## Roller

### Inspection of Rollers

1. Make sure that there is no abrasion nor adhesion of the roller.
2. Make sure that there is no wear of the roller shaft.
3. Make sure that there is no wear nor damage of the oil seal.
4. Make sure that there is no wear nor rust of the bearing.
5. Make sure that there is no play in the roller shaft.



# Handling Instructions

## Drum

### Inspection of Drum

1. Make sure that the drum is not cracked or damaged.
2. Make sure that there is no abrasion or adhesion of the drum.
3. Make sure that there is no play in the fit of the drum and the bearing.

## Tire

### Inspection of Tires

1. Make sure that there are no cracks, damage or abnormal wear.
2. Check the pneumatic pressure of the tires.

	Tire size	Pneumatic pressure	
Tire for traveling	4.10/3.50-6	120 kPa (1.2 kgf/cm <sup>2</sup> )	17 psi

## Brake

### Inspection of Brake

1. Grip the brake lever and make sure that the brake can operate completely.
2. Operate the lock lever and make sure that it can lock the brake lever.
3. Make sure that the brake is not applied even slightly after releasing the lock on the brake lever.

## Clutch

### Inspection of Clutch

1. Operate the clutch levers and check that the clutch operates perfectly.
2. Make sure that the clutch levers function well.

## Wire

### Inspection of Wire

1. Make sure that the wire is not cracked or damaged.
2. Make sure that the wire is not worn.
3. Make sure that the wire is not crushed.
4. Make sure that the wire is not bent.
5. Make sure that the wire is not corroded or rusted.

## Electrical Wiring

### Inspection of Electrical Wiring

#### Important

Electrical short circuit will cause fire, electrical leakage and malfunction of electrical equipments.

1. Make sure that there is no defacement in wires and terminals.
2. Make sure that there is no deterioration or damage in wires and terminals.
3. Make sure that there is no looseness in wiring connections.
4. Make sure that there is no poor terminal connection.

## Around The Engine

### Inspection of Engine-Associated Parts

#### Caution

Perform operations after the engine and other parts have sufficiently cooled. Otherwise, you may suffer burns.

1. Check for damages and dirt.
2. Check the mount for looseness and cracks.
3. Check for liquid leakage.
4. Check on and around the muffler for grass clippings and flammable materials.

### Cleaning Engine-Associated Parts

#### Caution

Perform operations after the engine and other parts have sufficiently cooled. Otherwise, you may suffer burns.

1. Clean clippings and remove dirt.
2. Blow compressed air to clean any grass or flammable materials that may be attached on or around the muffler.

# Handling Instructions

## Engine Oil

### Inspection of Engine Oil

**Important**

Screw the oil level gauge firmly.

1. Stop the engine, wait for 10 to 20 minutes for the engine to cool down, and then check the oil level.
2. Position the machine so that the engine will be level, then check the engine oil level without screwing the oil level gauge into the oil filling port.

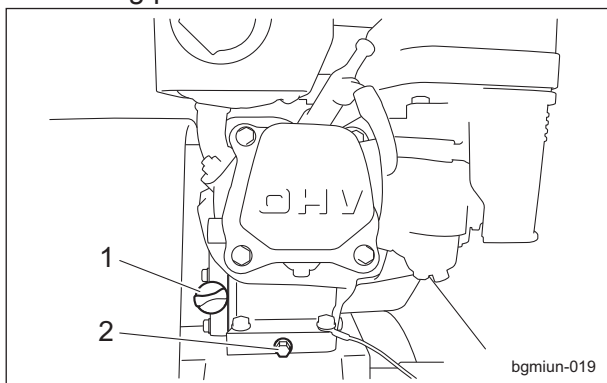

Inspection of Engine Oil\_001

1	Oil level gauge (Oil filling port)
2	Drain plug

3. The appropriate engine oil level should be between the upper and lower limit lines on the gauge.

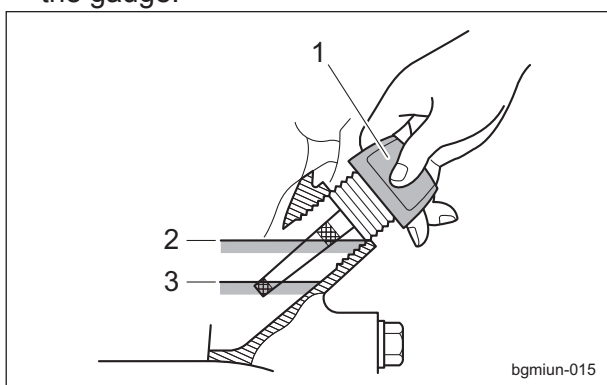

Inspection of Engine Oil\_002

1	Oil level gauge
2	Upper limit
3	Lower limit

4. Screw the oil level gauge firmly.

### Supply of Engine Oil

**Important**

Do not supply too much engine oil. Otherwise, the engine may be damaged.

**Important**

Do not mix different types of engine oil.

**Important**

Be sure to use engine oil that is classified as API Service Grade SE or higher, with an SAE Viscosity that is appropriate for the operating environment (ambient temperature).

**Important**

Screw the oil level gauge firmly.

1. Remove the oil level gauge.
2. Through the oil filling port, supply new engine oil until the engine oil reaches a level in the upper limit lines on the oil level gauge.
3. Position the machine so that the engine will be level, then check the engine oil level without screwing the oil level gauge into the oil filling port.
4. Screw the oil level gauge firmly.

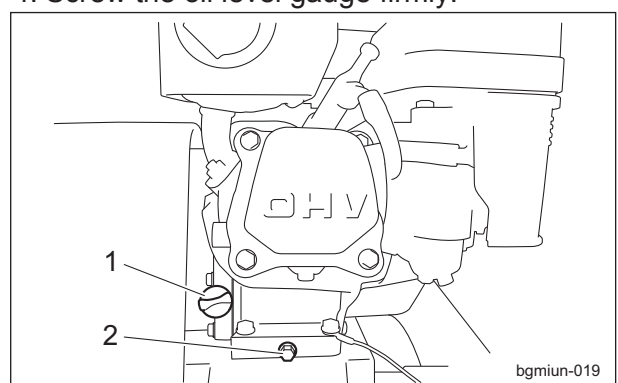

Supply of Engine Oil\_001

1	Oil level gauge (Oil filling port)
2	Drain plug

# Handling Instructions

## Fuel

### Inspection of Fuel Quantity

Level the machine and then remove the tank cap to inspect fuel quantity from the fill port.

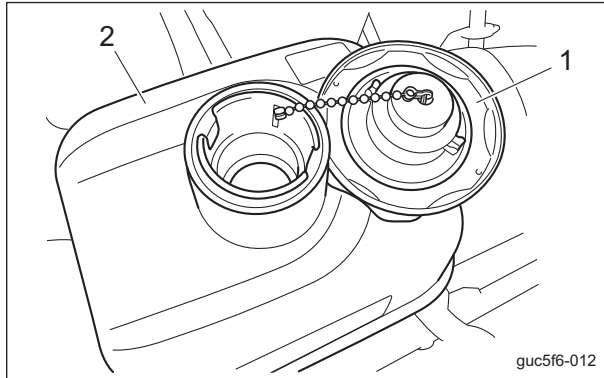

Inspection of Fuel Quantity\_001

1	Tank cap
2	Fuel tank

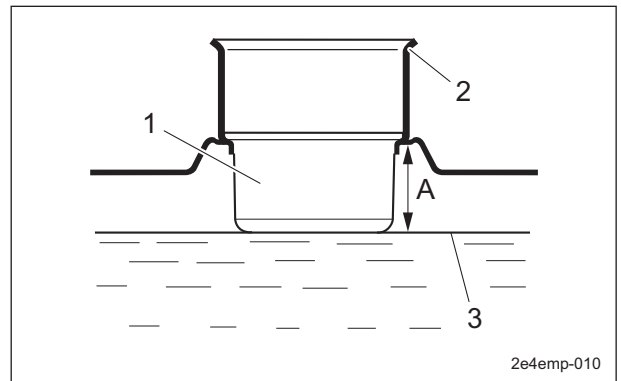

Fuel Supply\_001

1	Fuel strainer
2	Filling opening
3	Maximum limit of fueling
A	2.5 cm (0.98 in)

### Fuel Strainer

#### Inspection of Fuel Strainer

The fuel strainer is located in the piping for fuel supply system and removes contamination.

1. Make sure that there is no fuel leakage.
2. Make sure that the fuel strainer is not damaged or dirty.

#### Cleaning of Fuel Strainer

If dust or dirt accumulates in the fuel strainer, the fuel flow will become insufficient. Periodically clean it.

#### Important

Clean the fuel strainer in a clean location, free of dust and dirt.

1. Close the fuel cock of the fuel strainer.
2. Remove the strainer cup.
3. Clean the filter and the inside of the strainer cup with a solvent, such as hardly flammable kerosene.

### Fuel Supply

#### Caution

Do not supply fuel above FULL level of the fuel gauge.  
If you supply too much fuel, it might overflow from the fuel cap when you travel or work on a slope.

#### Caution

Keep fire away while refueling.  
Do not smoke while refueling.

#### Caution

Supply fuel after the engine is stopped and has well cooled down.

#### Caution

Pay attention not to touch hot parts.

Inspect the fuel quantity and put fuel (gasoline) if insufficient.  
The fuel tank capacity is approximately 2.0 dm<sup>3</sup> (2.0 L).

# Handling Instructions

4. Dry with compressed air.

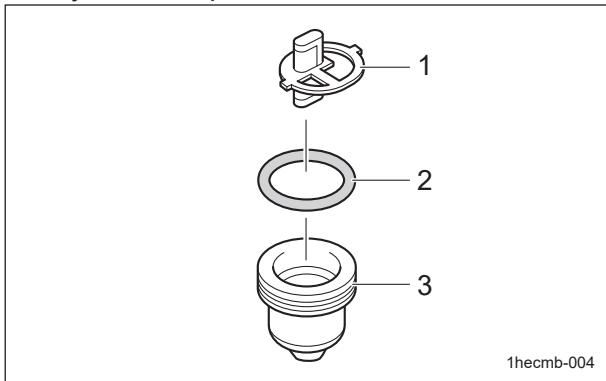

Cleaning of Fuel Strainer\_001

1	Filter
2	O ring
3	Strainer cup

**Important**

During installation, prevent contamination with dirt or dust. If the fuel is contaminated with dirt, dust, etc., the fuel flow will become insufficient.

5. Correctly install all parts in their original positions.
6. Fill up the fuel tank with fuel, and then open the fuel cock.
7. Make sure that there is no fuel leakage.

## Liquid Leakage

Inspection of Liquid Leakage

**Important**

After approximately 50 hours of operation, some tightened portions may be loosened and liquid such as oil may leak. Be sure to retighten the parts.

**Important**

If liquid leakage found, repair it before operation. Ignoring leakage will cause further trouble.

1. Check the bottom of the machine for leakage of liquid such as oil, water, etc.
2. Locate the leakage and identify the type of liquid.

## Bolts and Nuts

Inspection of Bolts and Nuts

**Important**

The bolts and nuts may be loosened at the earlier stage of the use. Be sure to retighten or replace before operating the machine whenever there is any abnormality.

1. Check the bolts and nuts for looseness and coming off.
2. Check the bolts and nuts for cracks and damages.
3. Check the bolts and nuts for rust.
4. Check around the bolts and nuts for traces of rust fluid.
5. Check for unequal bolt length.
6. Check the bolts and nuts for stripped threads and abrasion.

## Grass Catcher

Inspection of Grass Catcher

1. Make sure that there is no wear or deterioration of the grass catcher.
2. Make sure that there is no damage to the grass catcher.
3. Make sure that there is no interference to moving parts due to deformation of the grass catcher.

## Adjustment before Work

### Adjustment of Handle Position

The height of the handle can be adjusted according to the operator's working position. Move the handle adjusters supporting the handle up or down and fix them with the bolts.

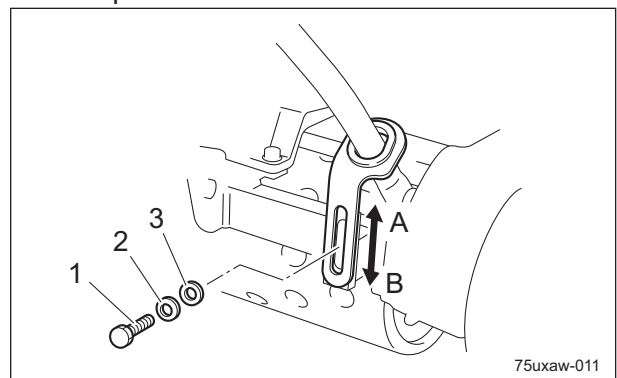

Adjustment of Handle Position\_001

1	Bolt
2	Conical spring washer
3	Washer
A	High
B	Low

1	Brake lever
2	Lock lever
A	Lock
B	Unlock

## Start/Stop of Engine

### Procedure to Start Engine

#### Caution

Before starting the engine, make sure that there are no other people or obstacles around the machine.

#### Caution

Make sure that the engine clutch cover is installed in the prescribed position.

1. Make sure that the engine switch is in the "OFF" position.

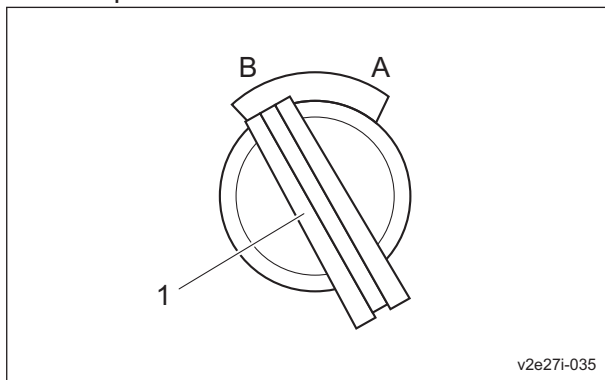

Procedure to Start Engine\_001

1	Engine switch
A	ON
B	OFF

2. Make sure that the brake is locked.

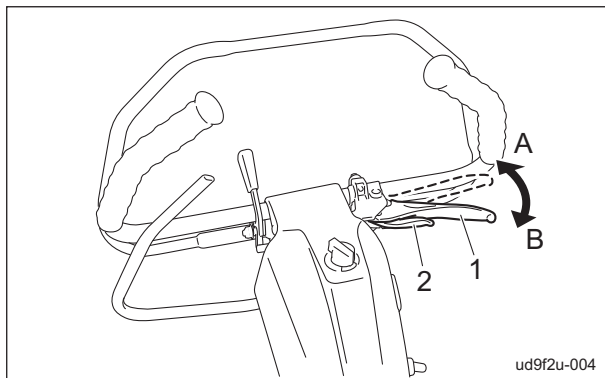

Procedure to Start Engine\_002

3. Don't grip the main clutch lever.

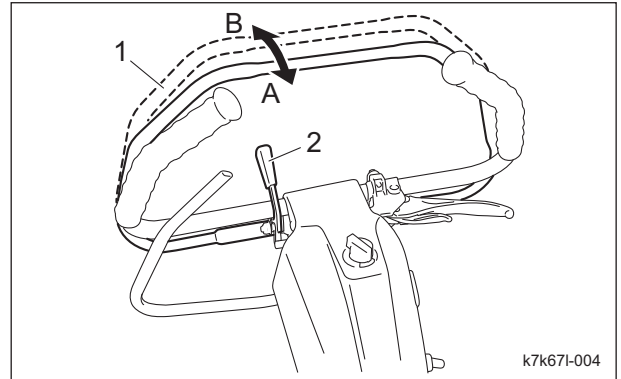

Procedure to Start Engine\_003

1	Main clutch lever
2	Clutch lock lever
A	ON
B	OFF

4. Set the fuel cock to the "Open" position.

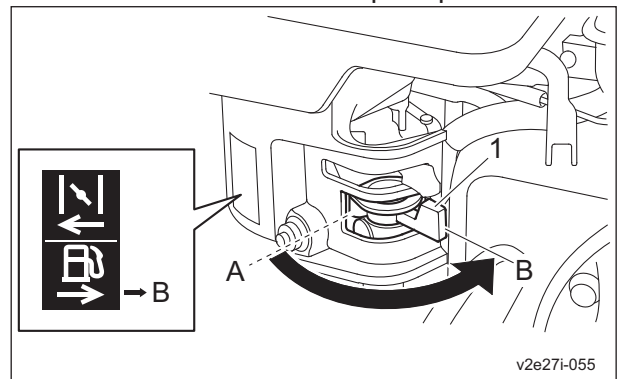

Procedure to Start Engine\_004

1	Fuel cock
A	Close
B	Open

# Handling Instructions

5. Set the engine switch to the "ON" position.

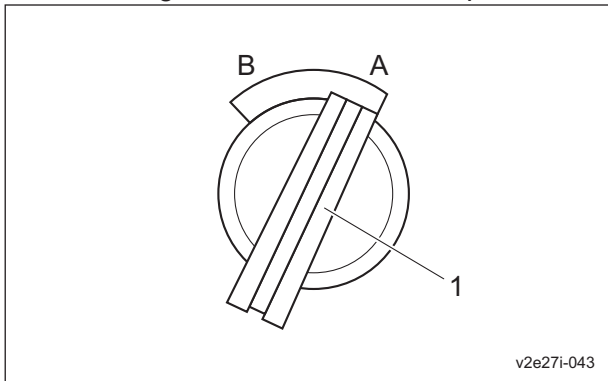

Procedure to Start Engine\_005

1	Engine switch
A	ON
B	OFF

7. Pull the starter grip swiftly, and the engine will start.

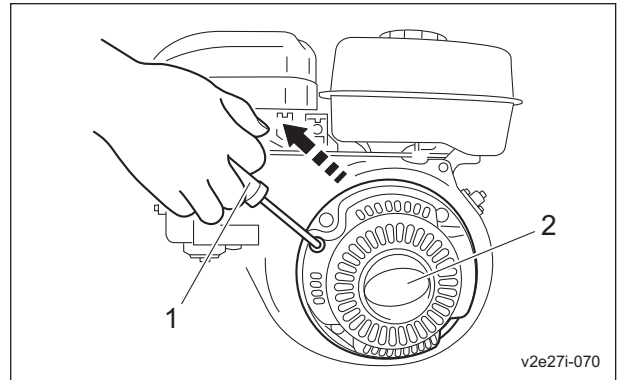

Procedure to Start Engine\_007

1	Starter grip
2	Recoil starter

6. Set the choke lever to the "Close" position.

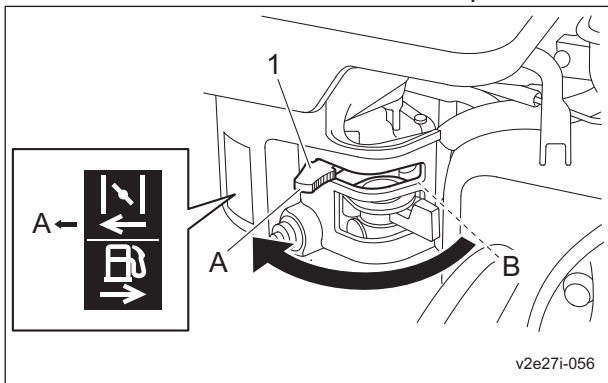

Procedure to Start Engine\_006

1	Choke lever
A	Close
B	Open

8. Set the choke lever to the "Open" position.

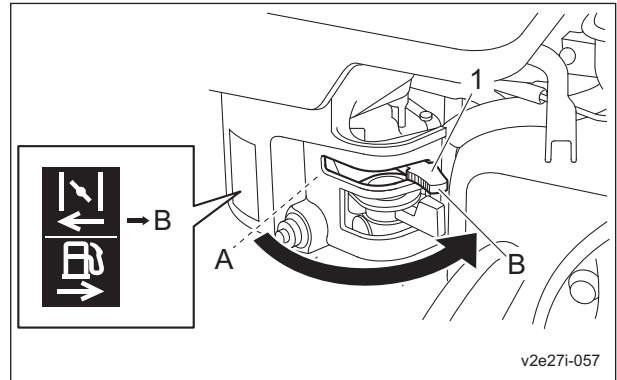

Procedure to Start Engine\_008

1	Choke lever
A	Close
B	Open

**Important**

Return the starter grip slowly to its original position after the engine starts. Do not let go of the pulled starter grip since it may cause damage to the machine.

## Procedure to Stop Engine

1. Don't grip the main clutch lever.

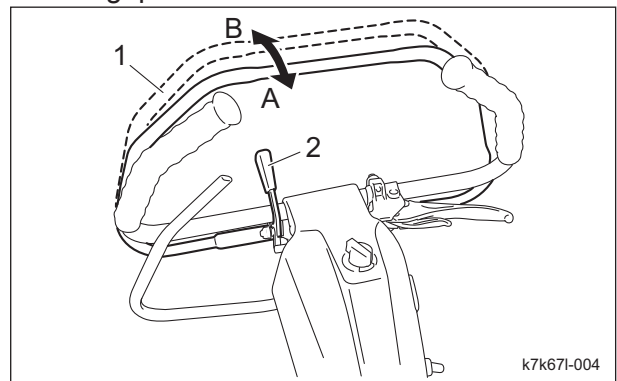

Procedure to Stop Engine\_001

# Handling Instructions

1	Main clutch lever
2	Clutch lock lever
A	ON
B	OFF

2. Set the engine switch to the "OFF" position.

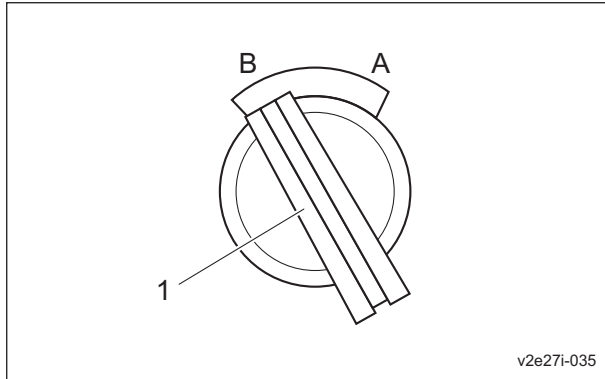

Procedure to Stop Engine\_002

1	Engine switch
A	ON
B	OFF

3. Make sure that the engine has stopped.
4. Make sure that the brake is locked.
5. Set the fuel cock to the "Close" position.

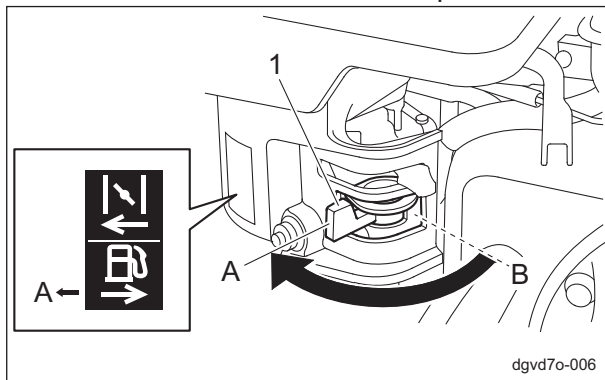

Procedure to Stop Engine\_003

1	Fuel cock
A	Close
B	Open

## Parking and Stopping

### Leaving The Machine

**Caution**

If the brakes are not sufficiently effective, use the wheel stoppers to secure the machine.

**Caution**

Do not park the machine on a slope.

**Caution**

Check that the engine has stopped.

1. Stop the machine on a flat place.
2. Make sure that the brake lever is locked.
3. Stop the engine.
4. Leave the machine.

## Move

### Traveling Procedure

**Caution**

Under any circumstances drive the machine at such a speed that you can stop it immediately for emergencies.

**Caution**

Do not start to move or stop the machine abruptly.

1. Install traveling tires.
2. Flip up the stand.
3. Set the traveling/working selector lever to "Travel ON" position of.
4. Start the engine.
5. Release the brake.
6. Release the safety lock and grip the main clutch lever slowly.
7. The machine starts traveling.
8. The machine stops when the main clutch lever released.

# Handling Instructions

## Cutting Work

### Cutting Work

**Warning**

Do not operate on a steep slope.

**Caution**

Do not start to move or stop the machine abruptly.

**Caution**

Be sure to operate at an appropriate speed for the mowing site.  
For mowing on an undulated surface, mow with lowered cutting speed.

**Important**

Be sure to attach the grass catcher.  
Discharge the clippings at the right time during operation.

1. Remove the traveling tires.
2. Flip up the stand.
3. Install the grass catcher.
4. Move the FOC (High/Low Clip) selector lever to the desired position.
5. Move the air adjusting plate to the desired position.
6. Move the groomer clutch lever to the desired position.
7. Move the traveling/working selector lever to the "Reel ON" position.
8. Start the engine.
9. Release the brake.
10. Release the safety lock and grip the main clutch lever slowly to start mowing.

Note:

Operate at about 3,000 rpm.

### Removing/Installing Traveling Tires

**Important**

Mow with the traveling tires removed.

Use the traveling tires to move the machine by self-propelling.

### Removal of traveling tires:

1. Set the machine on its stand.

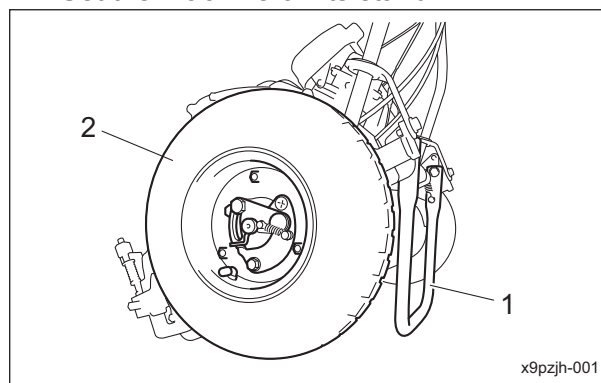

Removing/Installing Traveling Tires\_001

1	Stand
2	Traveling tires

2. While sliding the lever of the wheel mounting plate and holding it in the released position, pull the traveling tire toward you to remove it.

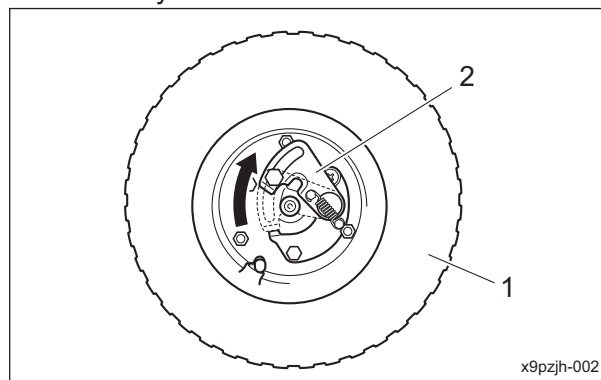

Removing/Installing Traveling Tires\_002

1	Traveling tires
2	Wheel mounting plate

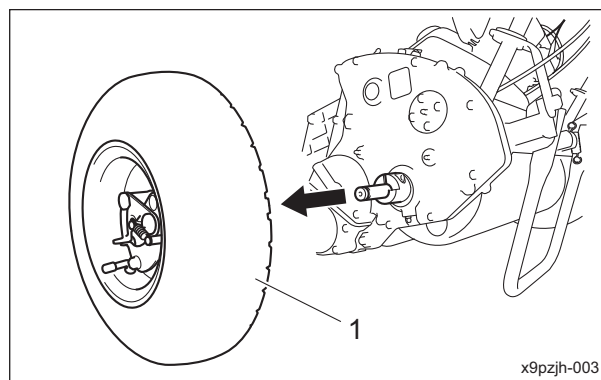

Removing/Installing Traveling Tires\_003

1	Traveling tires
---	-----------------

3. Follow the same steps to remove the traveling tire on the opposite side.



# Handling Instructions

Installation of traveling tires:  
Follow below steps to install the traveling tire.

1. Set the machine on its stand.

**Important**

The drum shaft and traveling tire have depressions and projections that fit together. Match the shapes during installation.

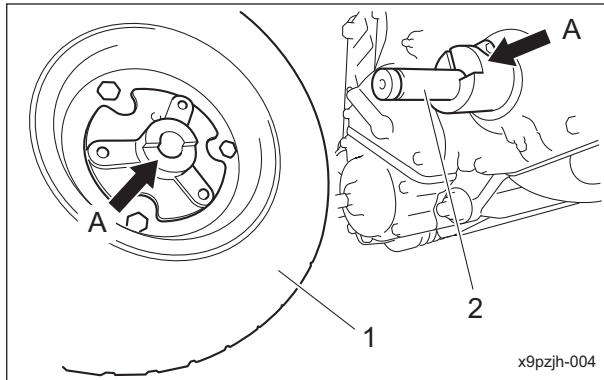

Removing/Installing Traveling Tires\_004

1	Traveling tires
2	Drum shaft
A	Depressions and projections that fit together

2. Install the traveling tire to the drum shaft.

**Important**

Make sure that the wheel mounting plate fits into the groove in the drum shaft. If they do not engage, the wheel may fall off.

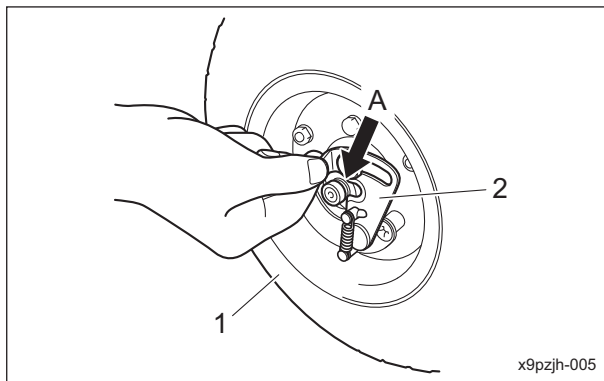

Removing/Installing Traveling Tires\_005

1	Traveling tires
2	Wheel mounting plate
A	Groove

## Removing/Installing Grass Catcher

**Caution**

Stop the engine before removing / installing the grass catcher.

Removing Grass Catcher:

Lift up the grass catcher to detach the right & left latches of it from the roller brackets.

Installing Grass Catcher:

Attach the right & left latches of the grass catcher to the roller brackets.

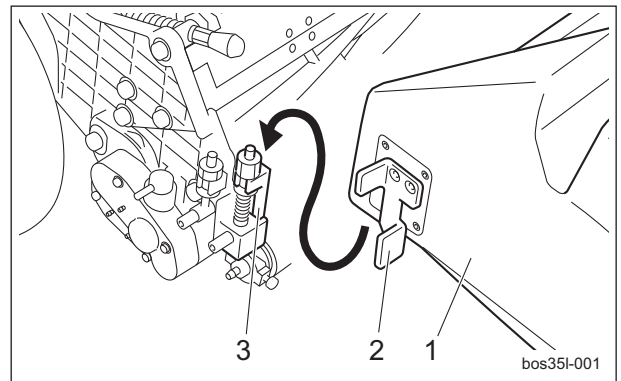

Removing/Installing Grass Catcher\_001

1	Basket
2	Latch
3	Roller bracket

# Handling Instructions

---

## Transporting

### Transporting Procedure

**⚠ Caution**

When loading and unloading the machine, wear non-slip shoes and travel slowly.

**Important**

When securing the machine with a rope, do not tie the rope to the engine.

**Important**

When securing the machine with a rope, be careful not to bend any wires.

Be extremely careful when loading the machine into a truck or a trailer.  
Before loading or unloading, stop the truck or trailer on a level surface in a safe location, apply the parking brake, stop the engine, and then chock the wheels.  
Before loading into a truck or a trailer for transportation, apply the parking brake of the machine, stop its engine, and then secure the machine with rope or any other sufficiently strong restraining device.  
When using a loading ramp, select one of sufficient length, width and strength, and that will not allow the machine to slip off.

<b>Precautions for Maintenance .....</b>	<b>Page 6-2</b>
<b>Position of Mower during Maintenance .....</b>	<b>Page 6-2</b>
<b>Greasing .....</b>	<b>Page 6-2</b>
About Greasing .....	Page 6-2
Greasing Points .....	Page 6-2
<b>Lubrication .....</b>	<b>Page 6-4</b>
About Lubrication .....	Page 6-4
Lubricating Points .....	Page 6-5
<b>Adjustment and Replacement .....</b>	<b>Page 6-5</b>
Adjustment of IGCA (Independent Grass Catcher Arm) .....	Page 6-5
Adjustment of Blade Engagement .....	Page 6-7
Adjustment of Cutting Height .....	Page 6-8
Adjustment of Groomer .....	Page 6-10
Adjustment of Cutter Adjustment Spring .....	Page 6-11
Adjusting CAM .....	Page 6-12
Back Lapping .....	Page 6-13
Sharpening of Reel Cutter (Cutting Cylinder) .....	Page 6-15
Replacement of Reel Cutter (Cutting Cylinder) .....	Page 6-16
Replacement of Bed Knife (Bottom Blade) .....	Page 6-18
Removing/Installing The Bed Knife Base .....	Page 6-18
Removing/Installing The Bed Knife .....	Page 6-22
Removing/Installing The Cover (Left) ..	Page 6-23
Change of Air Cleaner Element .....	Page 6-24
Replacement of Engine Oil .....	Page 6-24
<b>Storage .....</b>	<b>Page 6-25</b>
Long-Term Storage .....	Page 6-25

# Maintenance

## Precautions for Maintenance

**Warning**

The chapter "Maintenance" in this manual describes practical measures which should be performed by a mechanic with expertise. The owner should instruct the mechanic with expertise to perform maintenance service for this machine.

**Caution**

First, learn well the operations you plan to perform.

**Important**

Use tools appropriate for each operation.

**Important**

Use Baronsse genuine parts for replacement and accessories. Our product warranty may be void if you use non-genuine parts for replacement or accessories.

## Position of Mower during Maintenance

**Important**

If the mower is left for a long time during maintenance with the handle leaned on the ground or with the handle hoisted up, the engine oil will enter the engine combustion chamber and cause the engine to run improperly. After leveling the engine, be sure to start the engine in ten minutes to ensure sufficient time for any oil to drain back.

## Greasing

### About Greasing

Since there may be adhesion or damage due to lack of grease on moving parts, they must be greased. Add urea-based No. 2 grease in accordance with the Maintenance Schedule.

Other locations where the specified grease or lubricant is used are indicated in "Greasing Points". Add grease using the specified grease or lubricant.

### Greasing Points

Grease nipples are installed in the following locations. Add grease to A every 10 hours, and B every 50 hours. If specified locations and periods are additionally described below, follow the instructions.

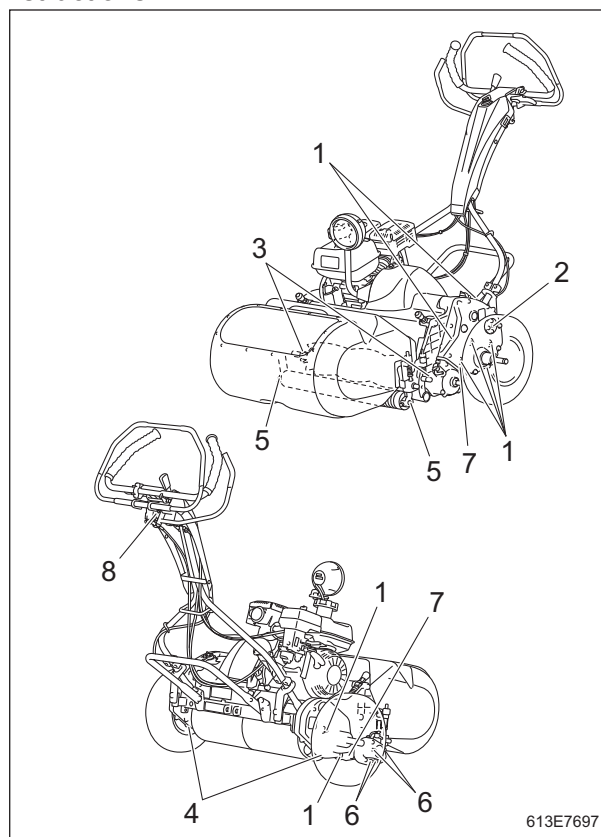

Greasing Points\_001

	Location	No. of greasing points	Greasing period	
			A	B
1	Frame & Transmission	8	A	B
2	Differential gear	1	A	-
3	Reel bearing	2	-	B
4	Drum housing	2	-	B
5	Front roller	2	-	B
6	Groomer	4	A	B
7	Cam bush	2	Refer to "Maintenance Schedule."	
8	Handle	1	-	B

### 1. Frame & Transmission

There are eight points in total on the left and right.

Right side

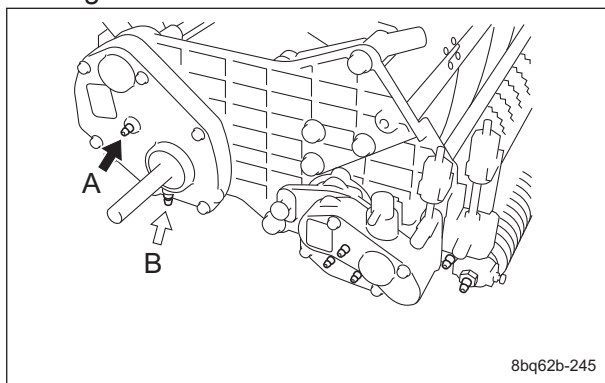

Greasing Points\_002

Left side

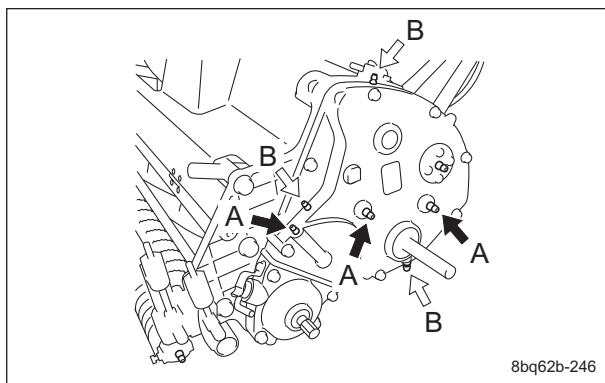

Greasing Points\_003

### 2. Differential gear

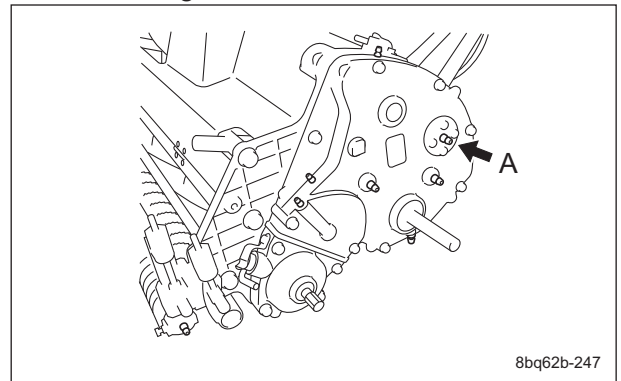

Greasing Points\_004

### 3. Reel bearing

Before the initial greasing, remove the elastic adhesive on the tips of the grease nipples with a flat-blade screwdriver, etc.

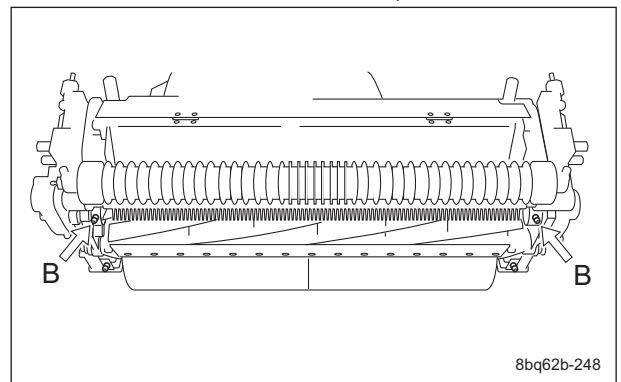

Greasing Points\_005

### 4. Drum housing

Before the initial greasing, remove the elastic adhesive on the tips of the grease nipples with a flat-blade screwdriver, etc.

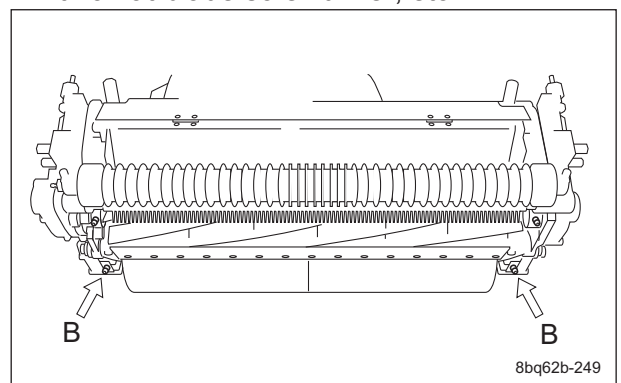

Greasing Points\_006

# Maintenance

## 5. Front roller

There is one point each on the left and right.

Right side

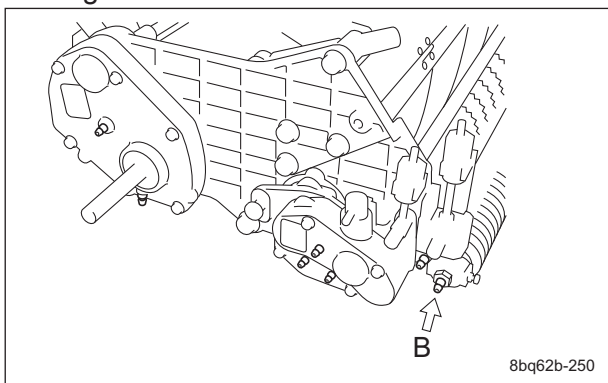

Greasing Points\_007

Left side

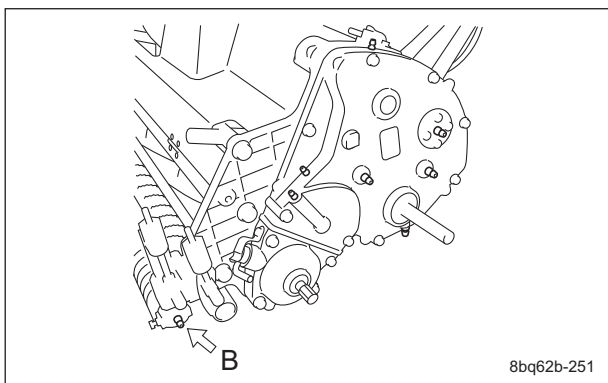

Greasing Points\_008

## 6. Groomer

Note:

Depending on the specifications, this function may not be available.

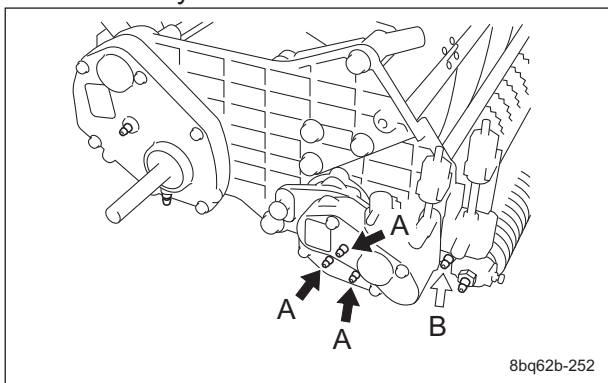

Greasing Points\_009

## 7. Cam bush

There is one point each on the right and left sides.

Apply 0.5 g (0.001 lb) of grease to outer perimeter of the cam bush pipe according to the maintenance schedule.

Left side

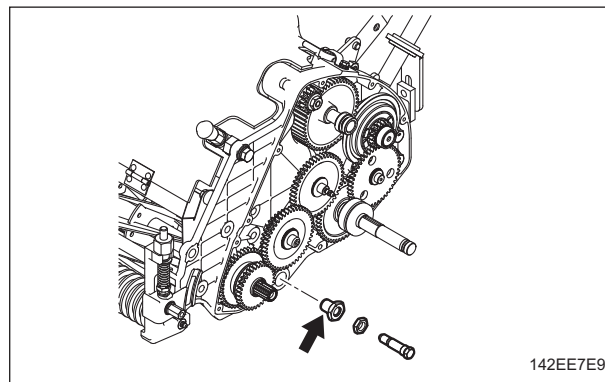

Right side

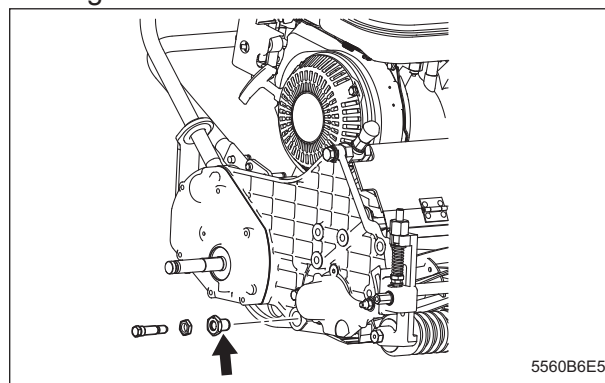

## 8. Handle

• Main clutch lever

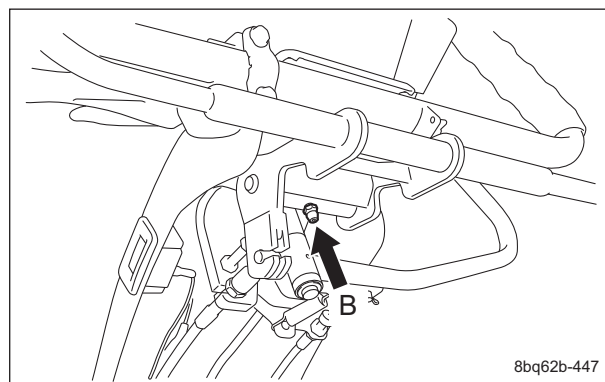

Greasing Points\_010

## Lubrication

### About Lubrication

It is necessary to lubricate moving parts so that they will not become stuck or damaged. The locations where lubricant is used are indicated in "Lubricating Points". Apply the lubricant.

## Lubricating Points

There are oil filling ports at the following locations.  
Apply lubricant every 50 hours of operation.

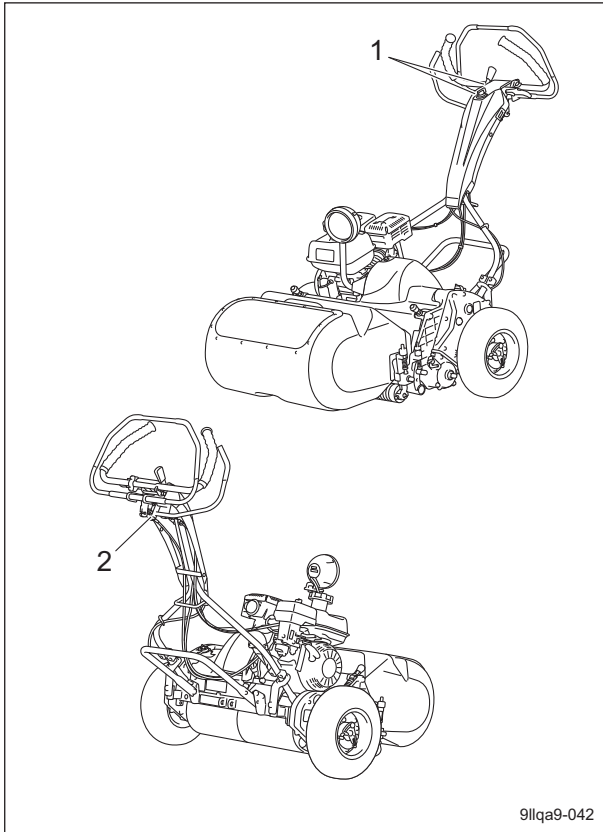

Lubricating Points\_001

	Location	No. of greasing points
1	Clutch lock lever fulcrum	2
2	Throttle lever fulcrum	1

### 1. Clutch lock lever fulcrum

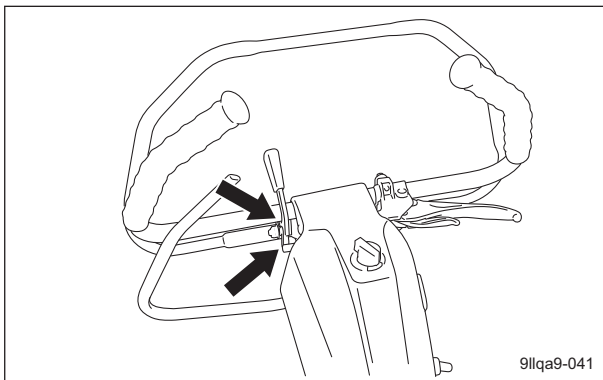

Lubricating Points\_002

### 2. Throttle lever fulcrum

Note:

Depending on the specifications, this function may not be available.

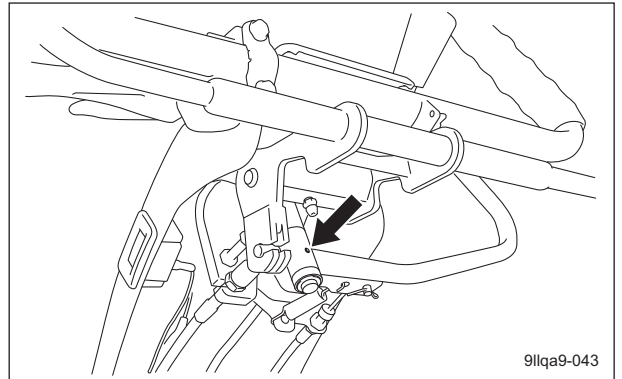

Lubricating Points\_003

## Adjustment and Replacement

### Adjustment of IGCA (Independent Grass Catcher Arm)

Note:

Depending on the specifications, this function may not be available.

#### Important

When adjusting the height of handle, adjust IGCA.

1. Remove the traveling tires.
2. Flip up the stand.
3. Install the grass catcher.

Adjustment of the link rod:

#### Important

Adjust the handle pipe so that it can locate at the center of the handle guide.

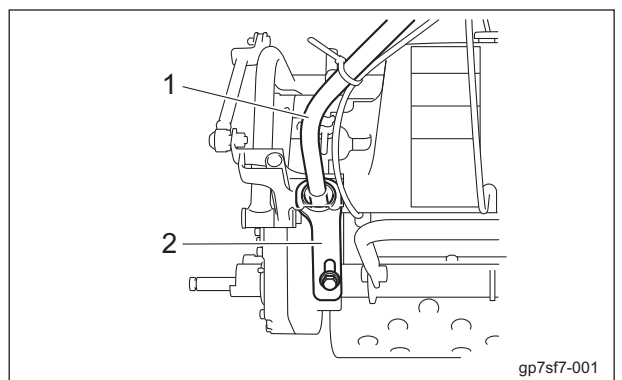

Adjustment of IGCA (Independent Grass Catcher Arm)\_001

1	Handle pipe
2	Handle guide

# Maintenance

**Important**

Adjust the right and left link rods so that they will be as long as each other.

1. Remove the snap pin and washer and then remove the flat head pin.
2. Loosen the nut A and turn the L-shape bracket to adjust the length of the link rod. When raising the handle, shorten the link rod. When lowering the handle, lengthen the link rod.
3. Attach the flat head pin, washer and snap pin to the forefront of slotted hole of the L-shape bracket.
4. Make sure that the handle pipe locates at the center of the handle guide.
5. Tighten the nut A.

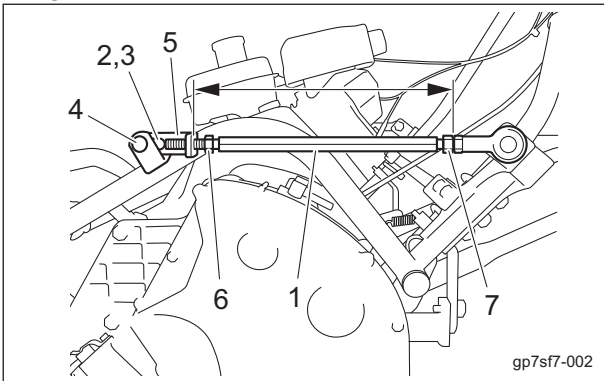

Adjustment of IGCA (Independent Grass Catcher Arm)\_002

1	Link rod
2	Snap pin
3	Washer
4	Flat head pin
5	L-shape bracket
6	Nut A
7	Nut B

6. Repeat the same process for adjustment of the opposite link rod.

Adjustment of gap for the grass catcher:

**Important**

Adjust so that the grass catcher will not overlap with the stay.

**Important**

Adjust so that the small gap between the grass catcher and the stay will be even.

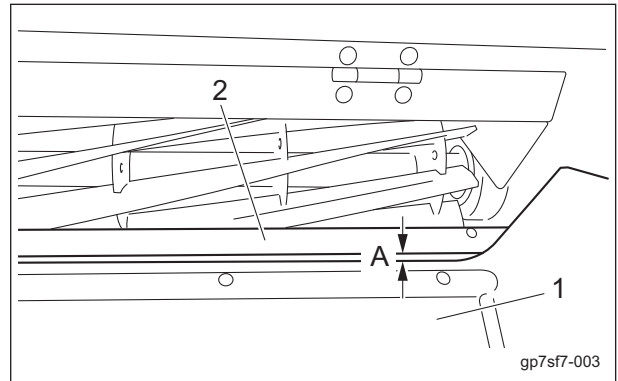

Adjustment of IGCA (Independent Grass Catcher Arm)\_003

1	Grass catcher
2	Stay
A	Gap

1. Loosen the right and left locknuts.
2. Remove the right and left clip pin.

**Important**

The shaft has a through-hole into which the clip pin will be inserted.

To adjust length always turn the shaft 180 degrees to keep holes aligned.

3. Turn the right and left shafts to adjust so that the gap between the grass catcher and the stay will be 1.0 mm (0.039 in).
4. Tighten the right and left locknuts.

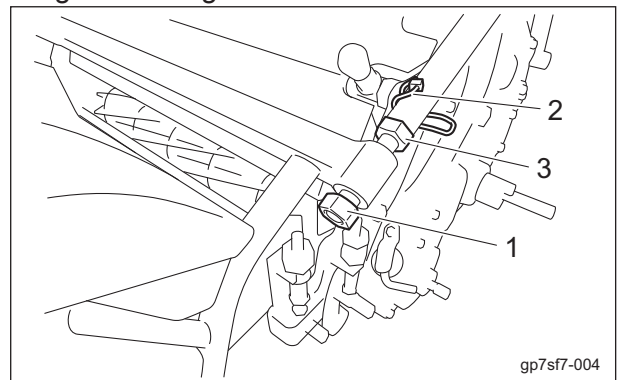

Adjustment of IGCA (Independent Grass Catcher Arm)\_004

1	Locknut
2	Clip pin
3	Shaft



## Adjustment of Blade Engagement

**Caution**

When handling the reel cutter (cutting cylinder) or bed knife (bottom blade), wear gloves to protect your hands. Pay attention not to let the reel cutter (cutting cylinder) catch your gloves. Otherwise, you may injure your hand or fingers.

1. Stop the engine.
2. Set the traveling/working selector lever to the "Travel OFF" position.

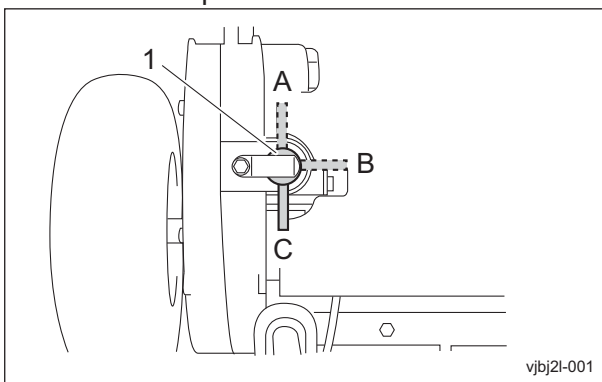

Adjustment of Blade Engagement\_001

1	Traveling/Working selector lever
A	Reel ON
B	Travel ON
C	Travel OFF

3. Shift the FOC (high/low clip) selector lever to the "Stop" position.

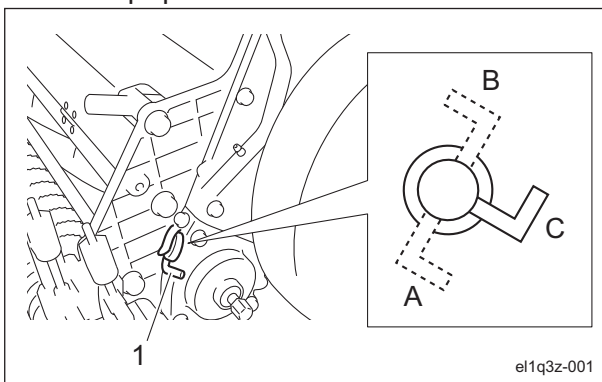

Adjustment of Blade Engagement\_002

1	FOC (high/low clip) selector lever
A	High speed
B	Low speed
C	Stop

4. With the cutter adjustment nut, adjust the engagement between the reel cutter (cutting cylinder) and the bed knife (bottom blade) so that newspaper (one sheet) will be cleanly cut by the edge of both blades when the blades in their entirety come slightly into contact with each other.
5. Insert a strip of newspaper into the space between the reel cutter (cutting cylinder) and the bed knife (bottom blade) at an angle of 90 degrees. Then, rotate the reel cutter (cutting cylinder) counter-clockwise (when you face the mower unit from the left) to check the sharpness of the blades. Check the sharpness of the entire range (at three or four points) of the reel cutter (cutting cylinder).

- If there is a gap between the blade edges: Loosen (rotate counter-clockwise) the cutter adjustment nut to apply more contact pressure between the reel cutter (cutting cylinder) and the bed knife (bottom blade).
- If the reel cutter (cutting cylinder) is too tight to turn: Tighten (rotate clockwise) the cutter adjustment nut to reduce the contact pressure between the reel cutter (cutting cylinder) and the bed knife (bottom blade).
- If the blades still cannot cut well: Perform back lapping of the reel cutter (cutting cylinder).

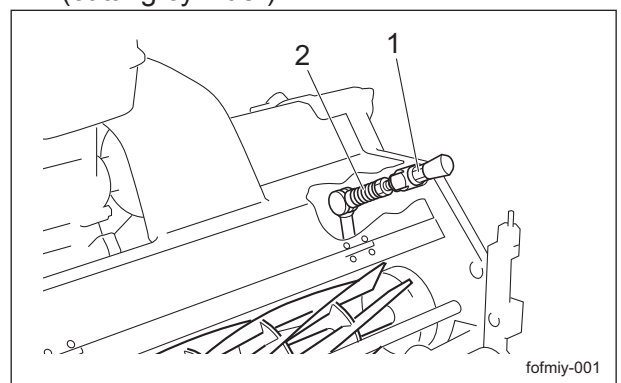

Adjustment of Blade Engagement\_003

1	Cutter adjustment nut
2	Spring

# Maintenance

## Adjustment of Cutting Height

### Important

This applies the set cutting height that differs from the actual cutting height.

Adjust the cutting height to fit your cutting work.

### Cutting Height and Blade Thickness of Bed Knife (Bottom Blade)

### Important

The recommended minimum cutting heights are based on those of common greens. These values are affected by the conditions of the greens and the machine specifications. If the green undulation is hard, set it a little bit higher in order not to damage the green surface.

The recommended minimum cutting height according to the blade thickness of the bed knife (bottom blade) is as indicated below.

Type	Blade type	Thickness of blade (mm/inch)	Rough minimum cutting height (mm/inch)	Code	Part name	Remarks	
LM18G C	Standard blade	1.0/0.039	2.5/0.098	K2511000480	1 Bed knife 18		
				K2511000500	1 Bed knife 18-44.5	Offset 2.5 mm	
		1.5/0.059	3.0/0.118	K2511000410	1.5 Bed knife 18G		Standard equipment
				K2511000440	1.5 Bed knife 18G-47	Offset 5 mm	
				K2511000430	1.5 Bed knife 18G-44.5	Offset 2.5 mm	
2.0/0.079	3.5/0.138	K2511000420	2 Bed knife 18G				
LM56G C	Standard blade	1.0/0.039	2.5/0.098	K2511000490	1 Bed knife 22		
				K2511000510	1 Bed knife 22-44.5	Offset 2.5 mm	
		1.5/0.059	3.0/0.118	K2511000270	1.5 Bed knife 55G		Standard equipment
				K2511000390	1.5 Bed knife 55G-47	Offset 5 mm	
				K2511000280	2 Bed knife 55G		
		2.0/0.079	3.5/0.138	K2511000350	2 Bed knife 55G-47	Offset 5 mm	
	2.5/0.098			4.0/0.157	K2511000050	2.5 Bed knife 55G	
		K2511000240	2.5 Bed knife 55G-47		Offset 5 mm		
High-speed-steel-tipped blade	3.0/0.118	4.5/0.177	K2510000060	3 Bed knife 62.5-559			
	5.0/0.197	7.0/0.276	K2510000160	5 Bed knife 62.5-559			
LM66T C	High-speed-steel-tipped blade	3.0/0.118	4.5/0.177	K2510000150	3 Bed knife 62.5-648.4	Standard equipment	
		5.0/0.197	7.0/0.276	K2510000170	5 Bed knife 62.5-648.4		

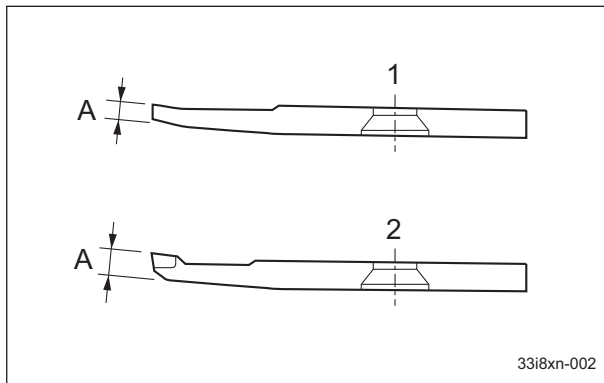

Cutting Height and Blade Thickness of Bed Knife (Bottom Blade)\_001

1	Standard blade
2	High-speed-steel-tipped blade
A	Thickness of blade

### Adjustment of Front Roller

You can adjust the cutting height by moving the front roller up or down.

The cutting height can be adjusted to the maximum of 29.0 mm (1.141 in).

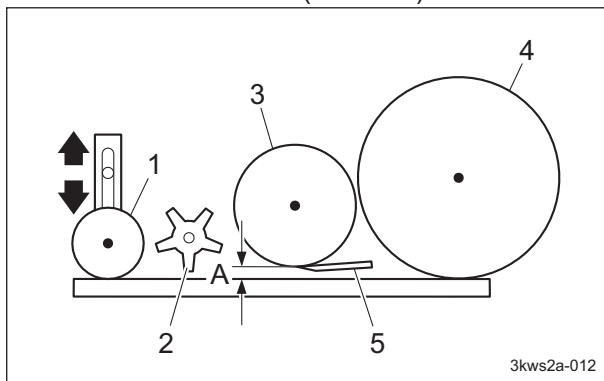

Adjustment of Front Roller\_001

1	Front roller
2	Front groomer
3	Reel cutter (Cutting cylinder)
4	Drum
5	Bed knife (bottom blade)
A	Cutting height

1. Set the slide caliper to the required cutting height, adjust the position of the bottom of the head of the small screw for cutting height setup in the cutting height gauge, and then securely lock it with a fly nut.

2. Loosen the nut securing the roller adjuster.

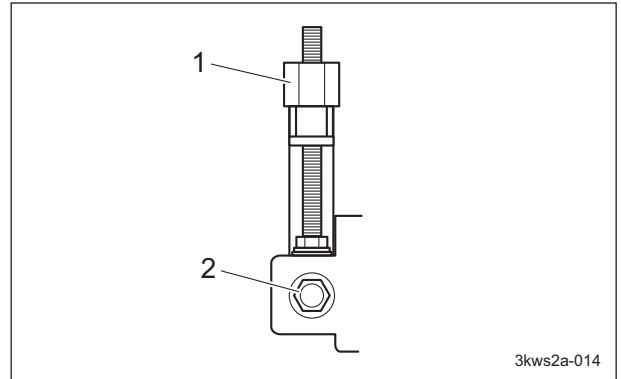

Adjustment of Front Roller\_002

1	Roller adjuster
2	Nut

3. Position the cutting height gauge against the front roller and drum at the edge on the left and right sides of the mower unit.
4. Move the front roller up or down with the roller adjuster to position the front roller so that there is no gap between the bottom of the head of the small screw for cutting height setup in the cutting height gauge and the edge of the bed knife (bottom blade).

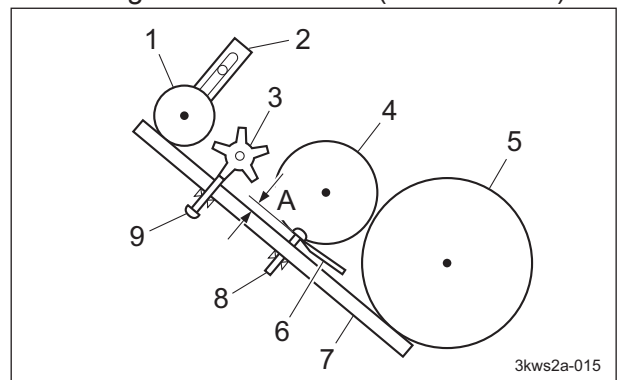

Adjustment of Front Roller\_003

1	Front roller
2	Roller bracket
3	Front groomer
4	Reel cutter (Cutting cylinder)
5	Drum
6	Bed knife (bottom blade)
7	Cutting height gauge
8	Small screw for cutting height setup
9	Small screw for groomer setup
A	Cutting height

5. Follow the same steps to adjust the cutting height on the opposite side.
6. Tighten the nuts that secure the left and right roller brackets to secure them firmly.

# Maintenance

7. Again, make sure that the cutting height is at the required position by positioning the cutting height gauge against the front roller and drum at the edge on the left and right sides of the mower unit.

## Adjustment of Groomer

**Note:**  
Depending on the specifications, this function may not be available.

1	Dethatching blade
2	Small screw for groomer setup
3	Cutting height gauge
4	Front roller
A	Groomer height

**Important**

If the front groomer is being used, adjust it according to the conditions of the greens.

**Important**

Set the grooming height more than 0.0 mm (0.00 in) from the ground. Allowing the front groomer to go into the ground will damage the groomer shaft.

**Important**

If the front groomer goes in too deep, the engine and drive components may become overloaded, which will cause malfunction and damage.

**Important**

When using the grooming brush, adjust it to the same height as the cutting height. If the grooming brush is too low, it may quickly become damaged.

1. Set the slide caliper to the required groomer height, adjust the tip of the groomer setting screw on the cutting height gauge, and then securely lock it with a wing nut.

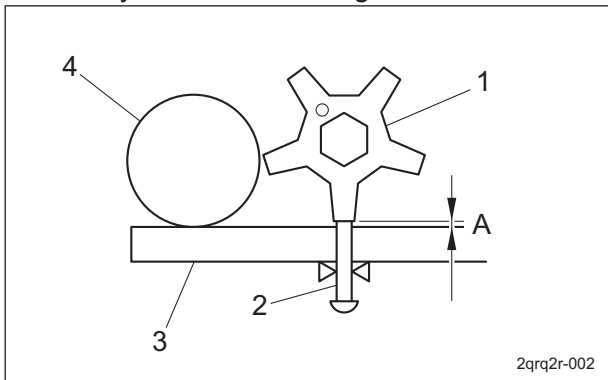

Adjustment of Groomer\_001

2. Loosen the nuts securing the left and right groomer adjustment screws.  
3. Loosen left and right special nut A.

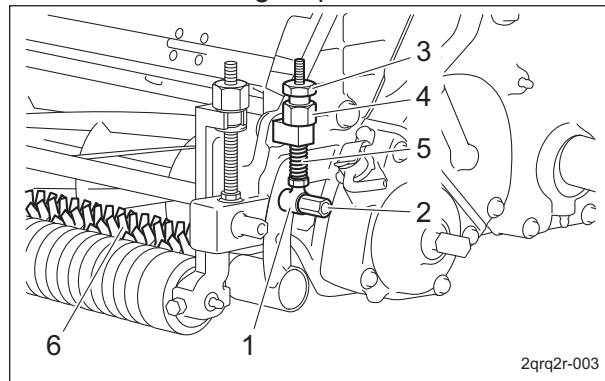

Adjustment of Groomer\_002

1	Groomer adjustment screw
2	Nut
3	Special nut A
4	Special nut B
5	Spring
6	Front groomer

4. Position the cutting height gauge against the front roller and drum at the edge on the left and right sides of the mower unit.

**Important**

Adjust so that the small screw for groomer setup contacts the dethatching blades.

5. Adjust special nut B up or down so that the left and right sides are parallel.

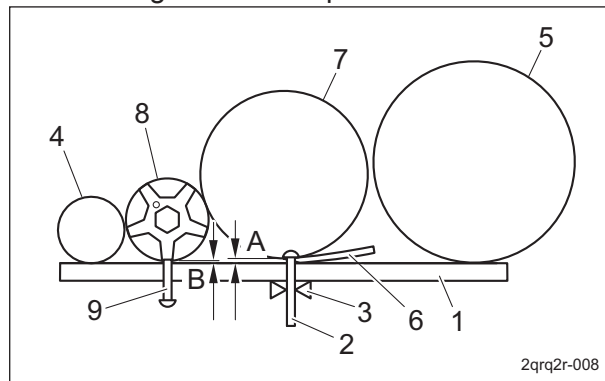

Adjustment of Groomer\_003

1	Cutting height gauge
2	Small screw for cutting height setup
3	Fly nut
4	Front roller
5	Drum
6	Bed knife (bottom blade)
7	Reel cutter (Cutting cylinder)
8	Dethatching blade
9	Small screw for groomer setup
A	Cutting height
B	Groomer height

6. Follow the same steps to adjust the groomer height on the opposite side.
7. Firmly tighten the nuts that secure the left and right groomer adjustment screws.
8. Tighten left and right special nut A.
9. Again, make sure that the groomer height is at the required position by positioning the cutting height gauge against the front roller and drum at the edge on the left and right sides of the mower unit.

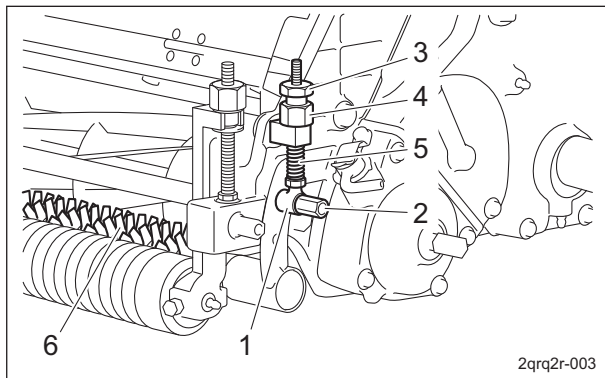

Adjustment of Groomer\_004

1	Groomer adjustment screw
2	Nut
3	Special nut A
4	Special nut B
5	Spring
6	Front groomer

**Note:**

In the case that the front groomer is not used, you do not have to change the set groomer height.

Loosen the nuts fixing the right and left groomer adjustment screws, lift the groomer and tighten the right and left nuts to raise the front groomer so that it cannot contact the lawn.

Next time the groomer is used, loosen the right and left nuts, lower the groomer and tighten the nuts so that it can return to the groomer height set previously.

## Adjustment of Cutter Adjustment Spring

**Caution**

When handling the reel cutter (cutting cylinder) or bed knife (bottom blade), wear gloves to protect your hands. Pay attention not to let the reel cutter (cutting cylinder) catch your gloves. Otherwise, you may injure your hand or fingers.

If the diameter of the reel cutter (cutting cylinder) becomes smaller, adjust the cutter adjustment spring.

1. Adjust the blade engagement.
2. Loosen the spring adjusting screw and the nut, and then adjust the length of the coil spring to 50.0 mm (1.97 in).

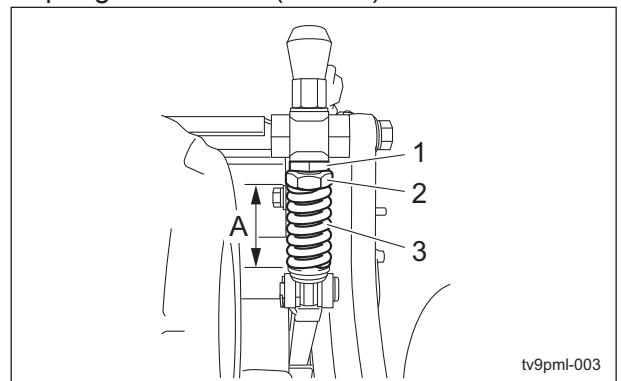

Adjustment of Cutter Adjustment Spring\_001

1	Spring adjusting screw
2	Nut
3	Spring
A	50 mm (1.97 in)

# Maintenance

## Adjusting CAM

Turn the cam bush on both sides of the bed knife (bottom blade), and the blade can be raised and lowered respectively by maximum 0.3 mm (0.012 in).

The above method is used when the edges of the reel cutter (cutting cylinder) and the bed knife (bottom blade) are not in parallel.

Check for the gap between the reel cutter (cutting cylinder) and the bed knife (bottom blade).

Loosen the locknut when adjusting the cam bush.

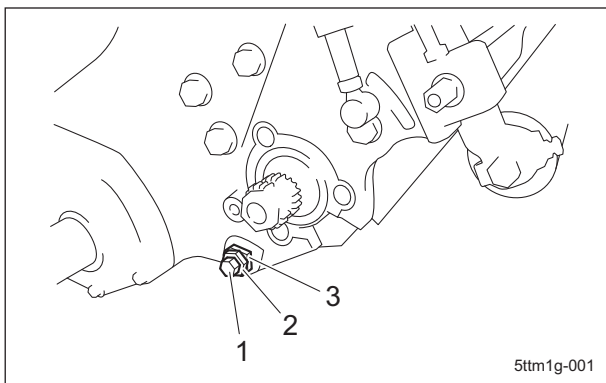

Adjusting CAM\_001

1	Cam bush
2	Locknut
3	Cutter pin

When the gap appears on the left side.:

1. Turn the left cam bush clockwise to eliminate only the gap distance.

When you raise the bed knife (bottom blade) by 0.1 mm (0.004 in), turn the left cam bush clockwise 30 degrees.

2. Once the adjustment completed, tighten the locknut securely.

When the gap appears on the right side.:

1. Turn the right cam bush counterclockwise to eliminate only the gap distance.

2. Once the adjustment completed, tighten the locknut securely.

Note:

The figure below shows the situation when you see from the left side.

The right side is mirror reversed.

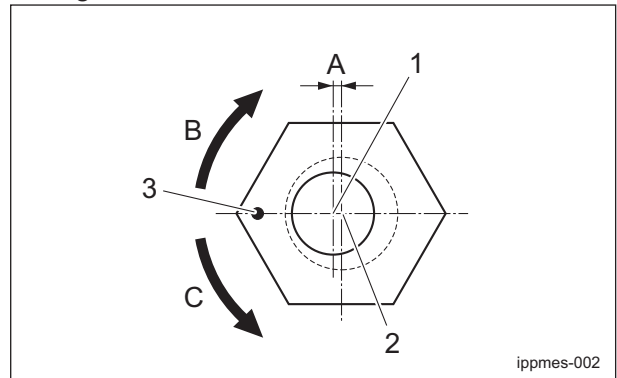

Adjusting CAM\_002

1	Center of cutter pin
2	Center of cam bush
3	Punch mark
A	0.3 mm (0.012 in)
B	Raising the bed knife
C	Lowering the bed knife.

## Back Lapping

Back lapping is work similar to sharpening a cooking knife. If the edges of the reel cutter (cutting cylinder) and the bed knife (bottom blade) become blunt and make cutting difficult, both the reel cutter (cutting cylinder) and the bed knife (bottom blade) should be simultaneously sharpened by reversing the reel cutter (cutting cylinder) with an abrasive paste applied.

However, back lapping is a temporary measure and would not restore the sharpness completely.

If the edges of the reel cutter (cutting cylinder) and the bed knife (bottom blade) become blunt and make cutting difficult, follow the steps below to perform back lapping.

**Warning**

During back lapping, the reel cutter (cutting cylinder) rotates. Keep hands and feet away from moving parts.

**Caution**

Do not perform back lapping with any other persons.

1. Have the following items ready: Strips of newspaper, Abrasive [Back lapping powder mixed with oil; or gel compound (Baroness genuine abrasive)], Brush.

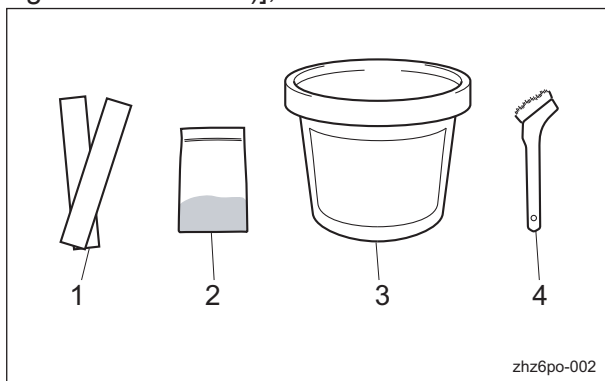

Back Lapping\_001

1	Newspaper
2	Back lapping powder
3	Gel compound
4	Brush

**Note:**

The mixing ratio for the abrasive, in volume, is one part back lapping powder (#200 - #400) to three or four parts oil.

2. Have a lapping machine or the lapping handle ready.

**Caution**

When handling the reel cutter (cutting cylinder) or bed knife (bottom blade), wear gloves to protect your hands. However, pay attention not to let the reel cutter (cutting cylinder) catch your gloves, etc. Otherwise, you may injure your hand or fingers.

**Important**

Check the sharpness of the blade by checking the blade engagement after cutting grass.

3. Stop the engine.
4. Set the traveling/working selector lever to the "Travel OFF" position.

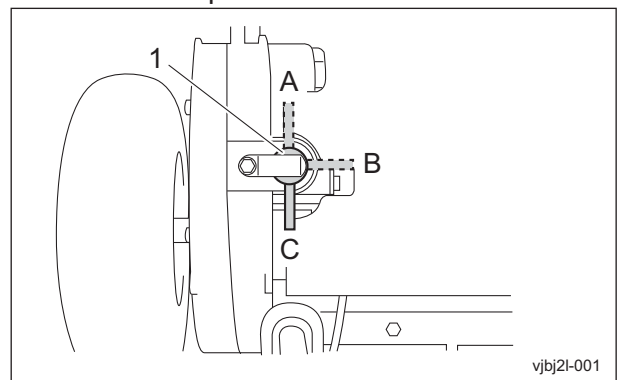

Back Lapping\_002

1	Traveling/Working selector lever
A	Reel ON
B	Travel ON
C	Travel OFF

# Maintenance

- Insert one or two strips of newspaper into the space between the reel cutter (cutting cylinder) and the bed knife (bottom blade) at an angle of 90 degrees. Then, rotate the reel cutter (cutting cylinder) counter-clockwise (when you face the mower unit from the left) to check the sharpness of the blades.

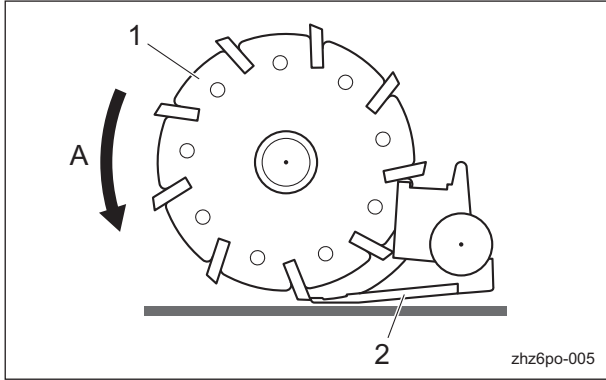

Back Lapping\_003

1	Reel cutter (Cutting cylinder)
2	Bed knife (bottom blade)
A	Rotation direction

- Check the sharpness of the entire range (three or four points) of the reel cutter (cutting cylinder).
- With a piece of chalk, etc., mark locations on the blade that are sharp.
- With a roller receiver, jack stand, etc., position the machine so that the bed knife (bottom blade) is level.

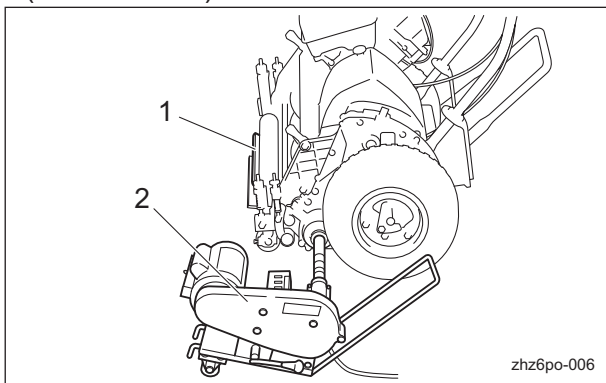

Back Lapping\_004

1	Roller receiver
2	Lapping machine

- Connect the lapping machine or lapping handle to the lapping bolt of the machine.

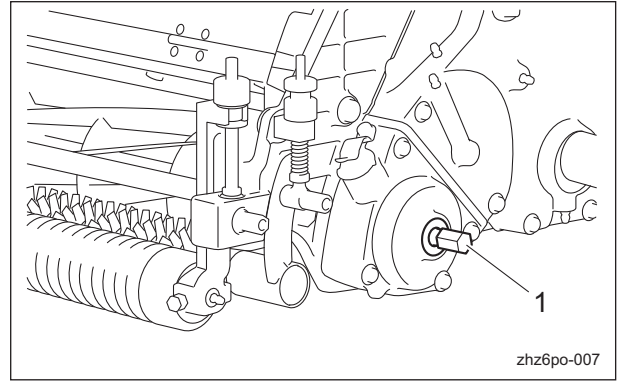

Back Lapping\_005

1	Lapping bolt
---	--------------

- Rotate the reel cutter (cutting cylinder) clockwise (reverse rotation) when you face the mower unit from the left.
  - Turn on the lapping machine. Otherwise, rotate the lapping handle.

### Important

The right side of the reel cutter (cutting cylinder) (when you face the mower unit from the front) is inclined to wear earlier than the left side. Accordingly be sure to move the brush from the left to the right to apply the abrasive.

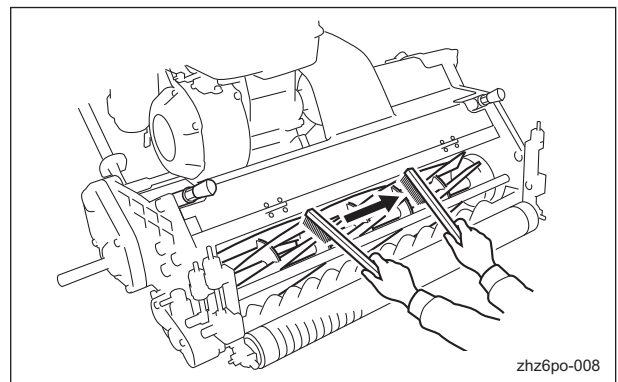

Back Lapping\_006

- Apply the abrasive evenly with the brush on the top side of reel cutter (cutting cylinder) where the newspaper was cut well or of chalk-marked locations. (Never apply to blunt areas.)
- Rotate the reel cutter (cutting cylinder) for a while and stop its rotation when the sound of contact is lost.
  - Turn off the lapping machine. Otherwise, stop rotating the lapping handle.



13. Remove the lapping machine or lapping handle.
14. Wash off or wipe off with a cloth, etc., the abrasive from the reel cutter (cutting cylinder), and then check the sharpness.
15. Repeat steps 5 to 14 until the entire range (three or four points) of the reel cutter (cutting cylinder) is uniformly sharpened.
16. Finally, apply abrasive to the entire blade width of the reel cutter (cutting cylinder) and perform final back lapping.

**Important**

When cleaning, do not allow water to come into contact with the engine or electrical components.

17. Wash off the abrasive with a washer, etc.
18. While checking the blade for sharpness, adjust blade engagement.

### Sharpening of Reel Cutter (Cutting Cylinder)

The sharpening of the reel cutter (cutting cylinder) consists in maintaining its roundness and creating a relief (second edge face). This work should be performed if the sharpness cannot be restored, even after back lapping, or if the relief (second edge face) has worn away.

Sharpen the reel cutter (cutting cylinder) when the sharpness cannot be restored, even after back lapping, or when the relief (second edge face) has worn away, there is full contact or back lapping takes too much time.

In addition, if the reel cutter (cutting cylinder) becomes worn and its shape conical, perform cylindrical grinding to return it to a cylindrical shape.

For sharpening the reel cutter (cutting cylinder), contact your dealer or Baroness unless you have a grinding machine.

**Caution**

Both the reel cutter (cutting cylinder) and the bed knife (bottom blade) are edged tools. Handle them carefully, since they could cut your hands and feet.

**Caution**

Wear gloves when touching edged tools to avoid cutting your hands.

The criteria for sharpening the reel cutter (cutting cylinder) are described below. However, these criteria are only references and do not guarantee performance of a reel cutter (cutting cylinder).

1. If the outer diameter of the reel cutter (cutting cylinder) after sharpening is more than the usage limit, the reel cutter (cutting cylinder) can be sharpened.

New		Usage limit	
Dimension A (Outer diameter of reel cutter (cutting cylinder))	Dimension B (Distance from blade edge to outer edge of reel cutter (cutting cylinder) shaft)	Dimension A (Outer diameter of reel cutter (cutting cylinder))	Dimension B (Distance from blade edge to outer edge of reel cutter (cutting cylinder) shaft)
128 mm (5.04 in)	51.3 mm (2.02 in)	118 mm (4.65 in)	46.3 mm (1.82 in)

**Note:**

The outer diameter of the reel cutter (cutting cylinder) shaft is 25.4 mm (1.00 in).

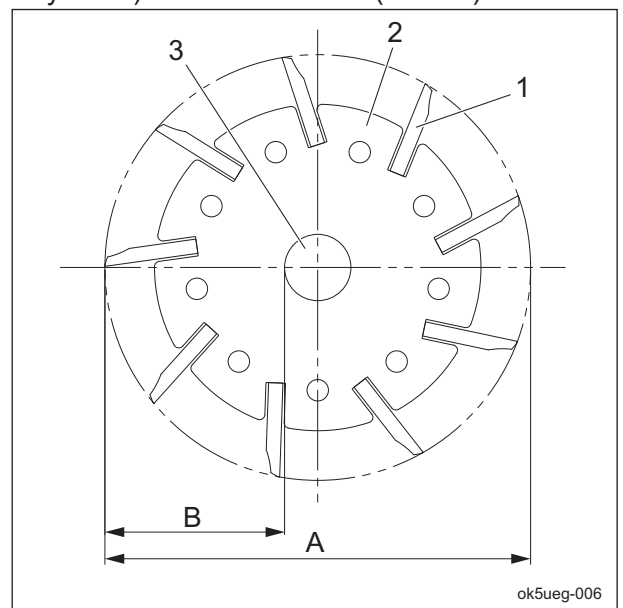

Sharpening of Reel Cutter (Cutting Cylinder)\_001

# Maintenance

1	Reel cutter (cutting cylinder) blade
2	Reel cutter (cutting cylinder) disc
3	Reel cutter (cutting cylinder) shaft
A	Outer diameter of reel cutter (cutting cylinder)
B	Distance from blade edge to outer edge of reel cutter (cutting cylinder) shaft

2. Sharpening is necessary when the reel cutter (cutting cylinder) reaches a condition described below.

[1] When the sharpening width (length of contacting surface of bed knife (bottom blade)) for the outer diameter of the reel cutter (cutting cylinder) is greater than the usage limit.

Outer diameter of reel cutter (cutting cylinder) (new part)	Usage limit of sharpening width for outer diameter of reel cutter (cutting cylinder)
128 mm (5.04 in)	2.5 mm (0.10 in) (factory-recommended)

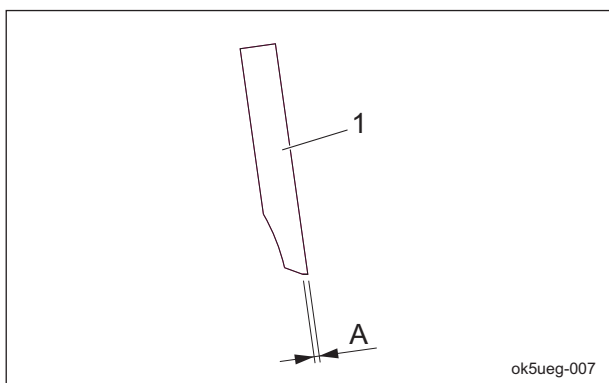

Sharpening of Reel Cutter (Cutting Cylinder)\_002

1	Reel cutter (cutting cylinder) blade
A	Sharpening width for outer diameter of reel cutter (cutting cylinder)

[2] When the edges become blunt or the blade edge cannot be formed with back lapping

[3] When the reel cutter (cutting cylinder) becomes worn and its shape conical, or when blade engagement adjustment cannot be performed

## Replacement of Reel Cutter (Cutting Cylinder)

### ⚠ Caution

Both the reel cutter (cutting cylinder) and the bed knife (bottom blade) are edged tools. Handle them carefully, since they could cut your hands and feet.

### ⚠ Caution

Wear gloves when touching edged tools to avoid cutting your hands.

The criteria for replacing the reel cutter (cutting cylinder) are described below.

However, these criteria are only a reference and do not guarantee performance like that of a new reel cutter (cutting cylinder).

1. When the outer diameter of the reel cutter (cutting cylinder) is less than the usage limit

New		Usage limit	
Dimension A (Outer diameter of reel cutter (cutting cylinder))	Dimension B (Distance from blade edge to outer edge of reel cutter (cutting cylinder) shaft)	Dimension A (Outer diameter of reel cutter (cutting cylinder))	Dimension B (Distance from blade edge to outer edge of reel cutter (cutting cylinder) shaft)
128 mm (5.04 in)	51.3 mm (2.02 in)	118 mm (4.65 in)	46.3 mm (1.82 in)

**Note:**

The outer diameter of the reel cutter (cutting cylinder) shaft is 25.4 mm (1.00 in).

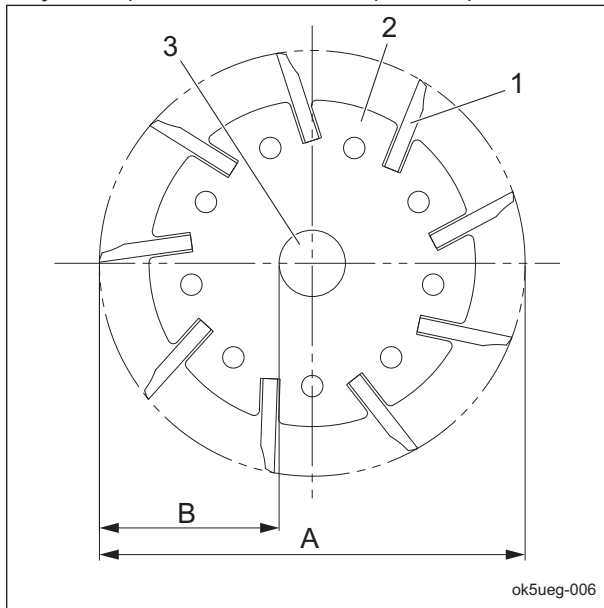

Replacement of Reel Cutter (Cutting Cylinder)\_001

1	Reel cutter (cutting cylinder) blade
2	Reel cutter (cutting cylinder) disc
3	Reel cutter (cutting cylinder) shaft
A	Outer diameter of reel cutter (cutting cylinder)
B	Distance from blade edge to outer edge of reel cutter (cutting cylinder) shaft

### Installing The Reel Cutter (Cutting Cylinder)

**Caution**

Both the reel cutter (cutting cylinder) and the bed knife (bottom blade) are edged tools. Handle them carefully, since they could cut your hands and feet.

**Caution**

When handling the reel cutter (cutting cylinder) or bed knife (bottom blade), wear gloves to protect your hands. Pay attention not to let the reel cutter (cutting cylinder) catch your gloves. Otherwise, you may injure your hand or fingers.

Follow the steps below to replace the bearings and oil seals on the left and right ends of the reel cutter (cutting cylinder).

**Important**

Use 30204JRP6 as bearing.

1. Fill up the bearings and oil seals with grease (Excelite EP No. 2).
2. Install the reel cutter (cutting cylinder) onto the frame.
3. Tighten the nut until the length of the spring reaches 11.5 mm (0.453 in), and then lock it.

**Note:**

Preloading with a constant force by spring pressure is possible.

4. Measure the rotating torque of the reel cutter (cutting cylinder) with a torque wrench.  
The specified value is 0.8 to 1.0 N·m (8 to 10 kgf·cm).

Specification without groomer:

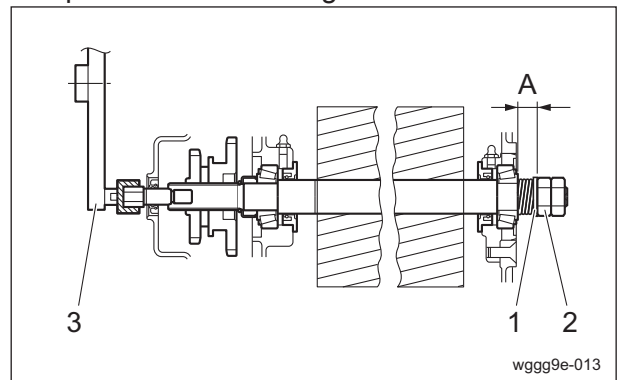

Installing The Reel Cutter (Cutting Cylinder)\_001

1	Washer
2	Left-hand nut
3	Torque wrench
A	11.5 mm (0.453 in)

Specification with groomer:

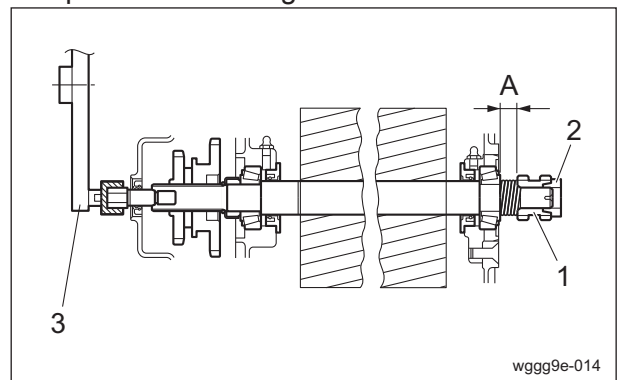

Installing The Reel Cutter (Cutting Cylinder)\_002

# Maintenance

1	Reel gear
2	Reel gear fixing nut
3	Torque wrench
A	11.5 mm (0.453 in)

## Replacement of Bed Knife (Bottom Blade)

### ⚠ Caution

Both the reel cutter (cutting cylinder) and the bed knife (bottom blade) are edged tools. Handle them carefully, since they could cut your hands and feet.

### ⚠ Caution

Wear gloves when touching edged tools to avoid cutting your hands.

The criteria for replacing the bed knife (bottom blade) are described below.

1. When the reel cutter (cutting cylinder) is ground
2. When the reel cutter (cutting cylinder) is replaced
3. When the bed knife (bottom blade) is worn  
Standard blade  
Replace the bed knife (bottom blade) before it no longer has a front face.

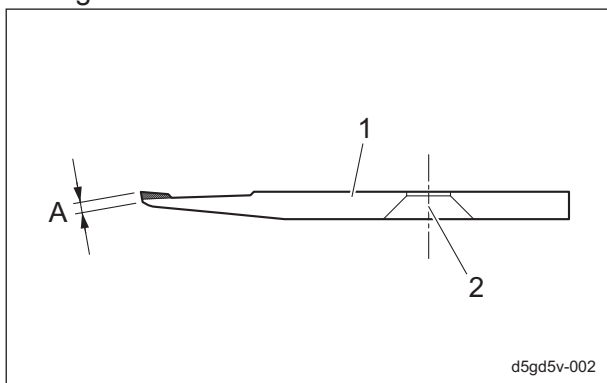

Replacement of Bed Knife (Bottom Blade)\_001

1	Bed knife (bottom blade)
2	Mounting hole
A	Front face

High-speed-steel-tipped blade  
Replace the bed knife (bottom blade) before it no longer has a tip.

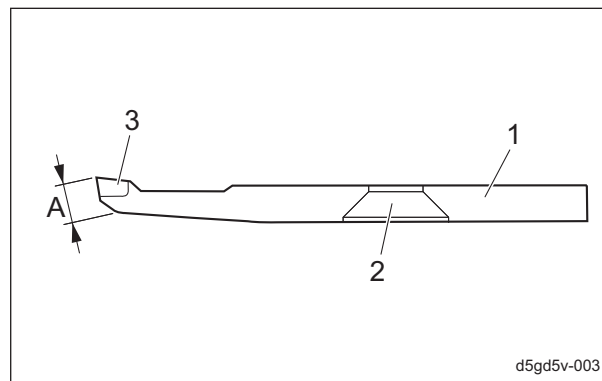

Replacement of Bed Knife (Bottom Blade)\_002

1	Bed knife (bottom blade)
2	Mounting hole
3	Tip
A	Front face

## Removing/Installing The Bed Knife Base

### Removing The Bed Knife Base

### ⚠ Caution

Both the reel cutter (cutting cylinder) and the bed knife (bottom blade) are edged tools. Handle them carefully, since they could cut your hands and feet.

### ⚠ Caution

Wear gloves when touching edged tools to avoid cutting your hands.

### ⚠ Caution

Raising the front part of the machine for servicing operation may create a falling hazard. Support the machine securely.

1. Loosen the lock nuts on both sides, and then loosen the cutter pins.

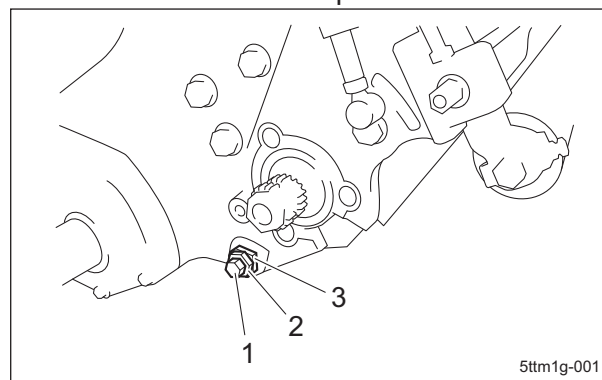

Removing The Bed Knife Base\_001

# Maintenance

1	Cutter pin
2	Lock nut
3	Cam bush

2. Remove the 2 bolts that secure the bed knife base arm Assy and bed knife base COMP.

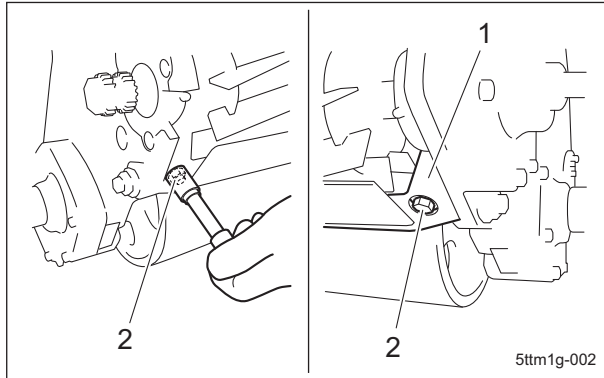

Removing The Bed Knife Base\_002

1	Bed knife base COMP
2	Bolt

**Important**

Keep 1 to 5 pieces of washer for clearance adjustment between the fulcrum seat and the frame if there are any of them.

3. Unscrew the fulcrum seat bolt, S washer, washer, and remove the bed knife base arm Assy from the bed knife base COMP.

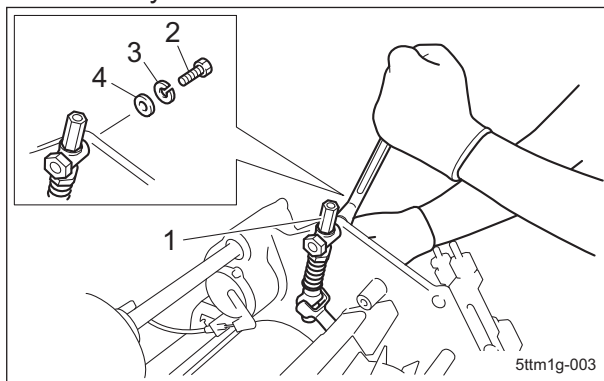

Removing The Bed Knife Base\_003

1	Bed knife base arm Assy
2	Bolt
3	S washer
4	Washer

**Caution**

Be careful when you remove the cutter pin as the bed knife base COMP may fall off.

4. While supporting the bed knife base COMP, remove the cutter pins and lock nuts on both sides.

5. Remove the bed knife base COMP.

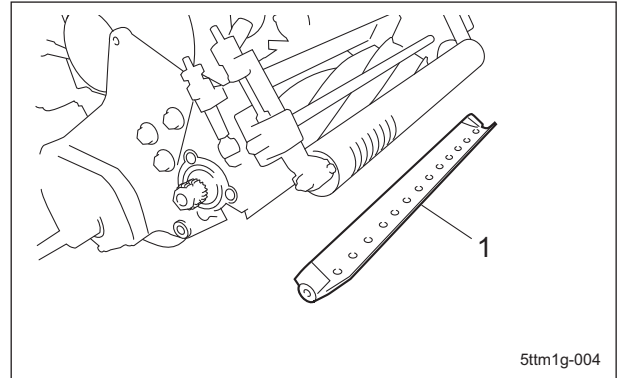

Removing The Bed Knife Base\_004

1	Bed knife base COMP
---	---------------------

## Installing The Bed Knife Base

**Caution**

Both the reel cutter (cutting cylinder) and the bed knife (bottom blade) are edged tools. Handle them carefully, since they could cut your hands and feet.

**Caution**

When handling the reel cutter (cutting cylinder) or bed knife (bottom blade), wear gloves to protect your hands. Pay attention not to let the reel cutter (cutting cylinder) catch your gloves. Otherwise, you may injure your hand or fingers.

**Caution**

While operations are performed with the front of the machine raised, it may fall. Securely support the machine.

**Important**

Make sure that there is no binding at the cam bushes in the frame of the mower unit.

1. Remove the right and left cam bushes.
2. Clean the cam bushes and the cam bush mounting portions on the frame and grease them.
3. Install the cam bushes.

# Maintenance

- Temporarily install the bed knife base COMP onto the machine with the left and right cutter pins and lock nuts.

Note:

At this time, tighten the lock nuts to the heads of the cutter pins, but do not allow the lock nuts to contact the cam bushes.

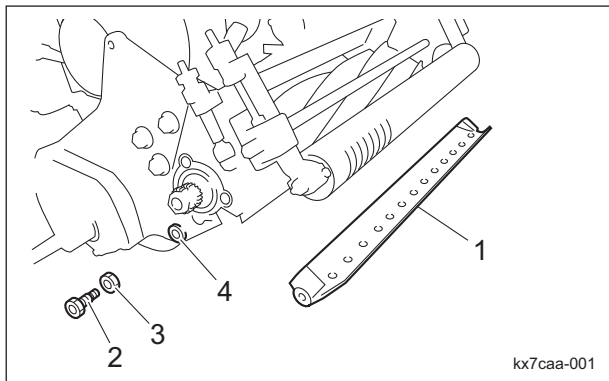

Installing The Bed Knife Base\_001

1	Bed knife base COMP
2	Cutter pin
3	Lock nut
4	Cam bush

**Important**

Install the bed knife base arm Assy parallel to the frame. During installation, be careful not to twist both arms.

- Insert the bed knife base arm Assy into the bed knife base COMP.
- Temporarily install the bed knife base arm with the bolt of the fulcrum seat.

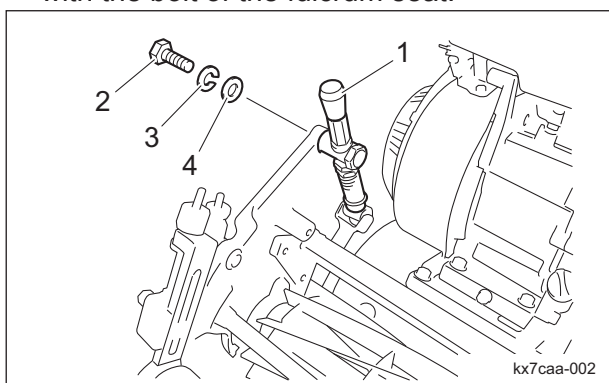

Installing The Bed Knife Base\_002

1	Bed knife base arm Assy
2	Bolt
3	Spring washer
4	Washer

- Tighten the bolt used to install the bed knife base arm Assy, and then firmly secure it.

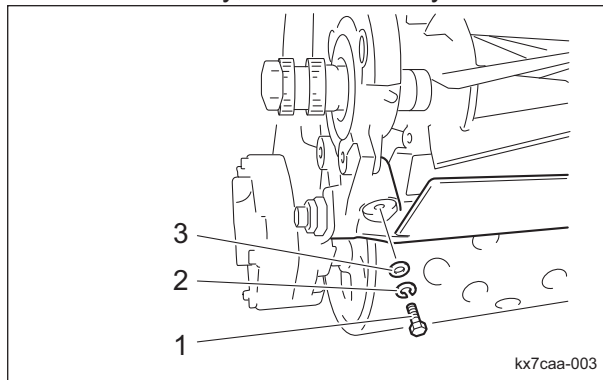

Installing The Bed Knife Base\_003

1	Bolt
2	Spring washer
3	Washer

**Important**

Do not tighten the left and right lock nuts.

- Tighten the left and right cutter pins used to temporarily install the bed knife base COMP.
- Remove the fulcrum seat bolt used to temporarily install the bed knife base arm. Note: With the weight of the bed knife base arm, the bed knife (bottom blade) will slightly come into contact with the reel cutter (cutting cylinder).
- Align the punch mark on each (left and right) cam bush with the travel direction.

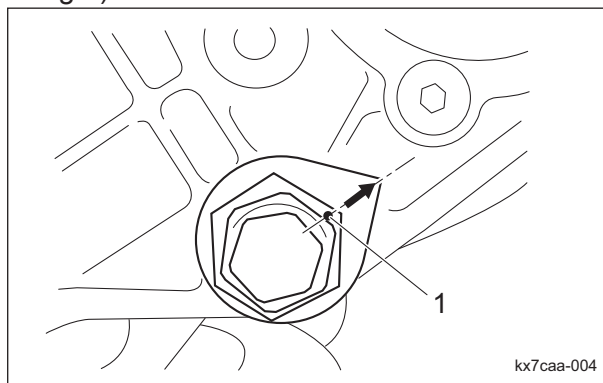

Installing The Bed Knife Base\_004

1	Punch mark
---	------------

11. Make sure that the bed knife (bottom blade) contacts the reel cutter (cutting cylinder).

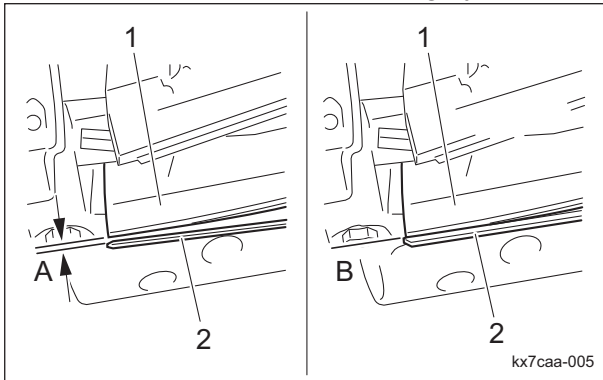

Installing The Bed Knife Base\_005

1	Reel cutter (Cutting cylinder)
2	Bed knife (bottom blade)
A	Gap
B	No gap

12. Insert one or two strips of newspaper into the space between the reel cutter (cutting cylinder) and the bed knife (bottom blade) at an angle of 90 degrees. Then, rotate the reel cutter (cutting cylinder) counterclockwise (as seen from the left side of the mower unit) by hand to check the sharpness of the entire range (three or four points) of the reel cutter (cutting cylinder).

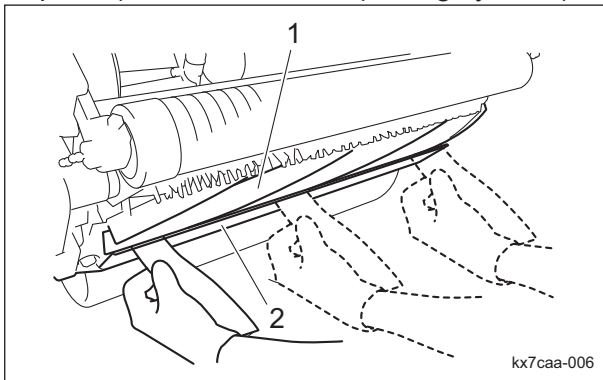

Installing The Bed Knife Base\_006

1	Reel cutter (Cutting cylinder)
2	Bed knife (bottom blade)

13. Adjust the positions of the cam bushes so that both sides cut.

"Adjusting CAM" (Page 6-12)

Note:

After making adjustments, use a marker, etc., to place a mark on the frame at the position of the punch mark.

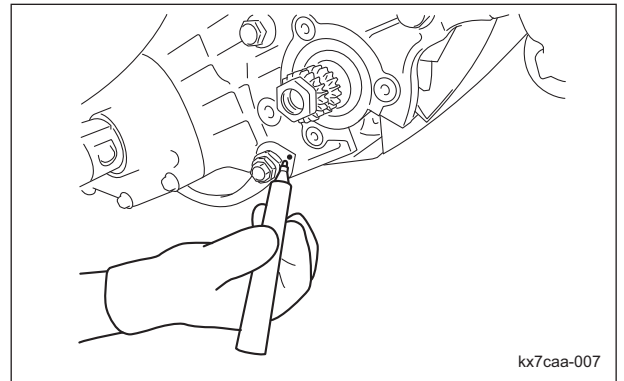

Installing The Bed Knife Base\_007

**Important**

If one to five gap adjustment washers had been inserted between the fulcrum seat and the frame, insert gap adjustment washers so that the gap is eliminated.

14. Install the fulcrum seats onto the left and right frames with the bolts, spring washers and washers.

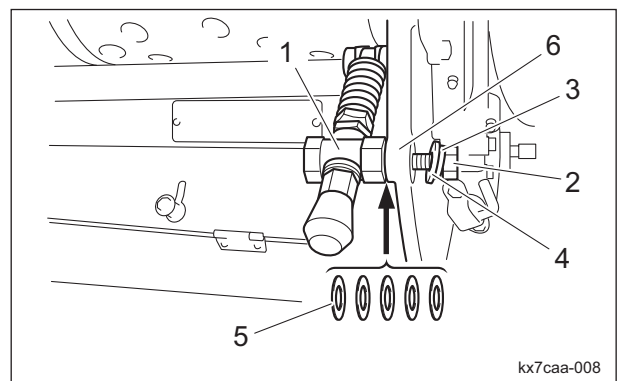

Installing The Bed Knife Base\_008

1	Fulcrum seat
2	Bolt
3	Spring washer
4	Washer
5	Gap adjustment washer
6	Frame

# Maintenance

15. Align the vertical hole in the fulcrum seat, and then secure it.

OK: The cutter adjustment bolt is centered in the hole of the fulcrum seat.

NG: The cutter adjustment bolt is not centered in the hole of the fulcrum seat.

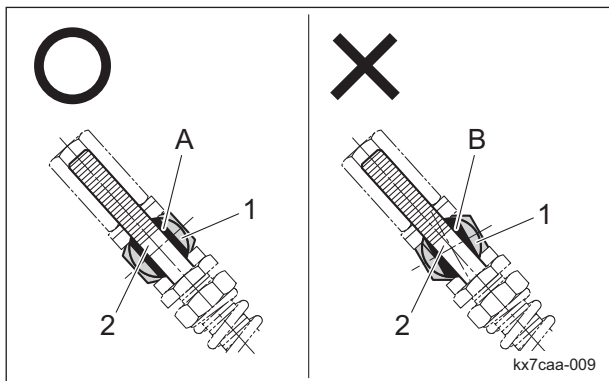

Installing The Bed Knife Base\_009

1	Fulcrum seat
2	Cutter adjustment bolt
A	OK
B	NG

### Important

Make sure that the cam bush does not move from the marked position.

16. Tighten the lock nuts of the left and right cutter pins.

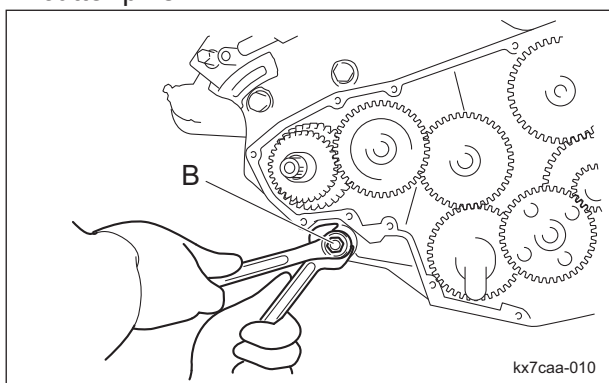

Installing The Bed Knife Base\_010

1	Lock nut
---	----------

## Removing/Installing The Bed Knife

### Removing The Bed Knife

#### Caution

Both the reel cutter (cutting cylinder) and the bed knife (bottom blade) are edged tools. Handle them carefully, since they could cut your hands and feet.

#### Caution

Wear gloves when touching edged tools to avoid cutting your hands.

#### Caution

While operations are performed with the front of the machine raised, it may fall. Securely support the machine.

1. Remove the bed knife base COMP.
2. Place the bed knife base COMP on a stable workbench.
3. Remove the bed knife by loosening the screw with a hammer driver or punch.

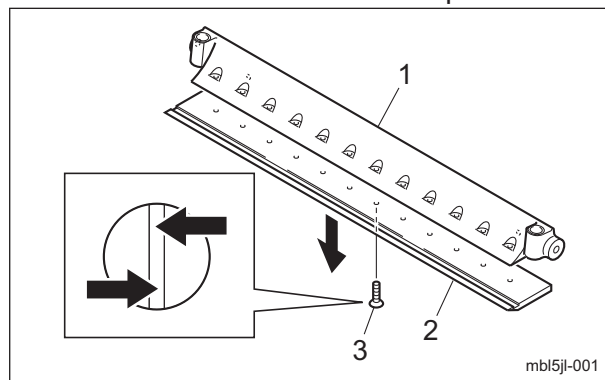

Removing The Bed Knife\_001

1	Bed knife base
2	Bed knife
3	Screw



## Installing The Bed Knife

**⚠ Caution**

Both the reel cutter (cutting cylinder) and the bed knife (bottom blade) are edged tools. Handle them carefully, since they could cut your hands and feet.

**⚠ Caution**

Wear gloves when touching edged tools to avoid cutting your hands.

**⚠ Caution**

While operations are performed with the front of the machine raised, it may fall. Securely support the machine.

**Important**

Be sure not to scratch the bed knife base surface where the bed knife shall be mounted. Remove rust and dust.

**Important**

Replace the old screws with new ones.

1. Tighten the screws uniformly with a hammer driver.

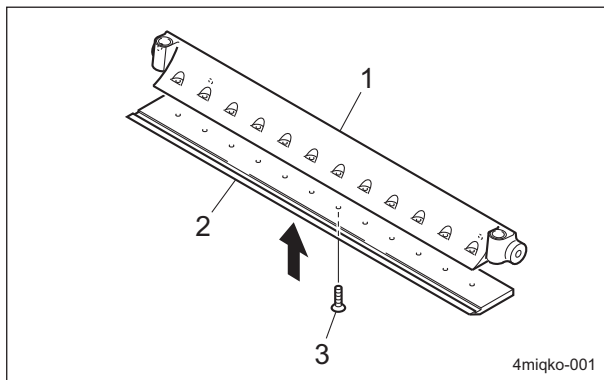

Installing The Bed Knife\_001

1	Bed knife base
2	Bed knife
3	Screw

**Note:**

When installing the bed knife, first tighten the center screw, and then tighten from center outwards, alternating between left and right sides.

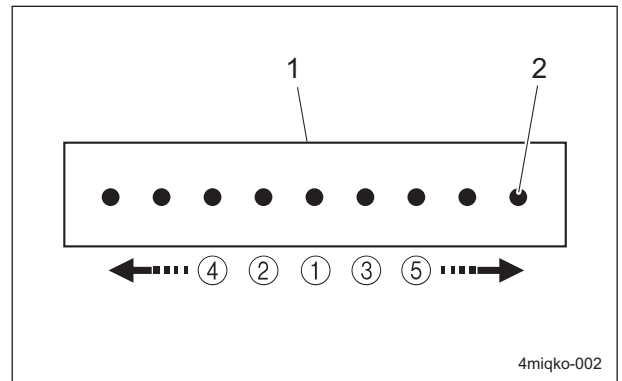

Installing The Bed Knife\_002

1	Bed knife
2	Screw

## Removing/Installing The Cover (Left)

### Removing The Cover (Left)

1. Insert an item such as a wooden hammer handle into the reel cutter to prevent the reel cutter from turning, and remove the special bolt.

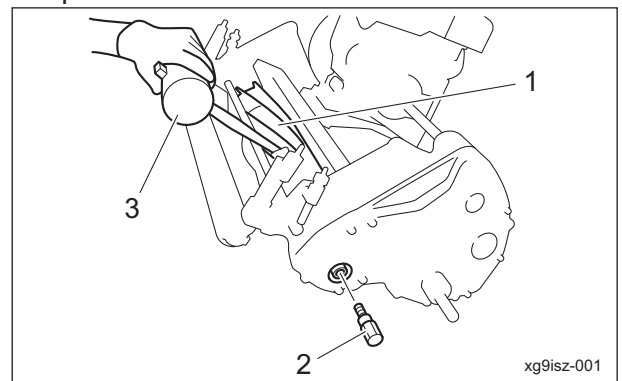

Removing The Cover (Left)\_001

1	Reel cutter
2	Special bolt
3	Wooden hammer

2. Remove the bolt, S Washer, Clutch retainer spring, and remove the FOC (High/Low Clip) selector lever.

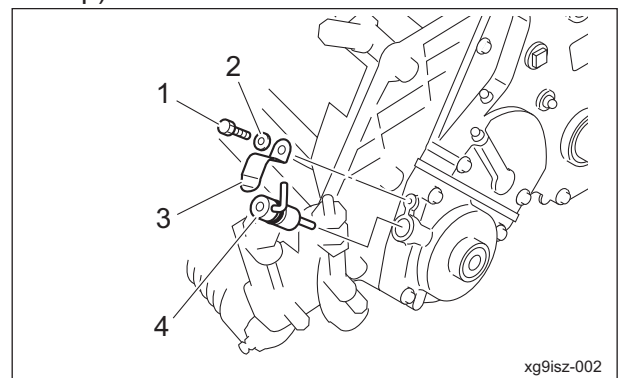

Removing The Cover (Left)\_002

# Maintenance

1	Bolt
2	S Washer
3	Clutch retainer spring
4	FOC (High/Low Clip) selector lever

- Loosen the hexagon socket head bolt, and then remove the wheel driving fitting.
- Remove the key from the drum shaft.

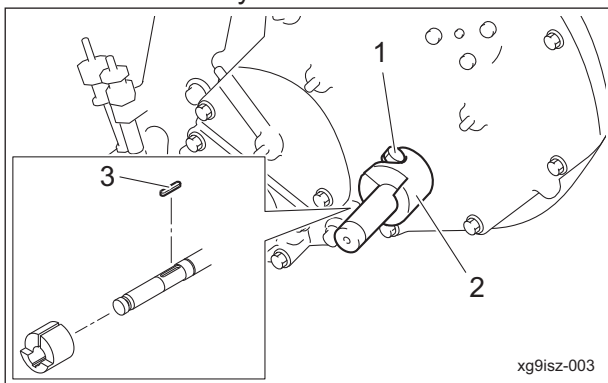

Removing The Cover (Left)\_003

1	Hexagon socket head bolt
2	Wheel driving fitting
3	Key

- Unscrew the 13 bolts, and then detach the cover (left).

**Notes:**

If the cover (left) doesn't come off easily, remove it by tapping these six locations (indicated by the arrows in the illustration) lightly with a wooden hammer etc.

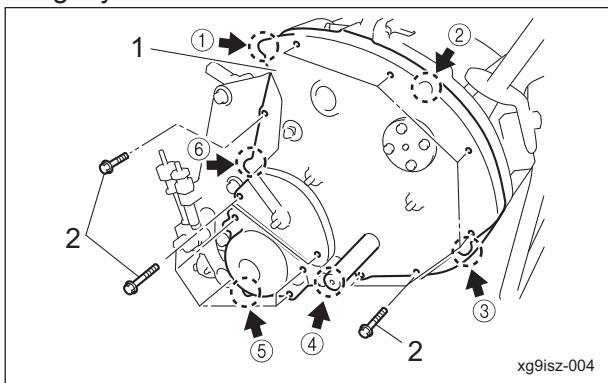

Removing The Cover (Left)\_004

1	The cover (left)
2	Bolt

### Installing The Cover (Left)

When installing the cover (left), follow the opposite procedure of removal.

## Change of Air Cleaner Element

**Important**

A contaminated air cleaner element may cause malfunction of the engine.

- The timing for replacing the air cleaner element is described below.

- Replace the air cleaner element in accordance with the Maintenance Schedule.
- If it is significantly contaminated, replace it, even if the hours of operation do not exceed the specified time.

- Replace the air cleaner element by following the same steps as for cleaning the air cleaner. "Cleaning of Air Cleaner Element" (Page 5-4)

## Replacement of Engine Oil

**Caution**

Be careful with hot oil, which could cause burns if it contacts your skin.

**Important**

When you replace the engine oil, be sure to drain it into a bowl and discard it in accordance with local laws and regulations.

**Important**

Be sure to use engine oil that is classified as API Service Grade SE or higher, with an SAE Viscosity that is appropriate for the operating environment (ambient temperature).

**Important**

Screw the oil level gauge firmly.

Replace the engine oil more frequently if the engine oil is contaminated, and especially if you use the machine in dusty areas or operate the engine at high loads or in high temperatures.

- Move the machine onto a level surface, stop the engine.

2. Remove the drain plug while the engine oil is warm, and then drain the engine oil into a bowl.
3. Replace the drain plug in the engine.
4. Remove the oil level gauge.
5. Through the oil filling port, supply new engine oil.  
The engine oil quantity is approximately 0.56 dm<sup>3</sup> (0.56 L).
6. Position the machine so that the engine will be level, then check the engine oil level without screwing the oil level gauge into the oil filling port.

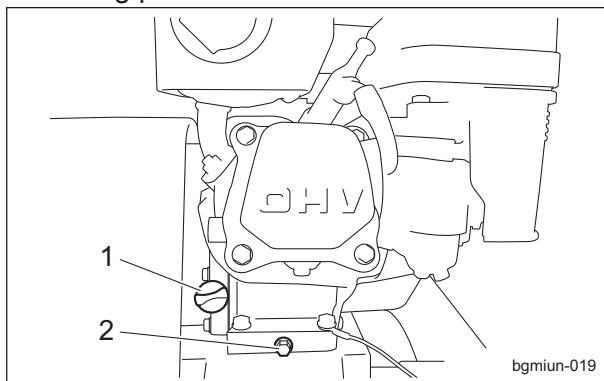

Replacement of Engine Oil\_001

1	Oil level gauge (Oil filling port)
2	Drain plug

7. After checking the oil level with the oil level gauge, add more engine oil if it is insufficient.
8. Securely tighten the oil level gauge.
9. Check underneath the machine for oil leakage.

## Storage

### Long-Term Storage

Follow the instructions below for long-term storage of the machine.

1. Cleaning
  - Remove dirt, grass clippings, oil stains etc. completely from the main vehicle and engine.
2. Replacing oil
  - Inspect and replace the engine oil and element.
3. Oil filling
  - Grease and lubricate the appropriate points.
4. Fuel
  - Remove the fuel from the fuel tank.

5. Tire pneumatic pressure
  - Set the tire air pressure slightly higher than normal, and then place the machine on a board to avoid humidity.
6. Storage location
  - Cover the machine and store it in a dry place where it will not be exposed to rain.

# Maintenance

---

**Precautions for Repair** ..... Page 7-2

**Adjustment and Replacement** ..... Page 7-2

Adjustment of Brake ..... Page 7-2

Adjustment of Engine Clutch Section .... Page 7-2

# Repair

## Precautions for Repair

### Warning

The chapter "Repair" in this manual describes practical measures which should be performed by a mechanic with expertise. The owner should instruct the mechanic with expertise to perform repair service for this machine.

### Caution

First, learn well the operations you plan to perform.

### Important

Use tools appropriate for each operation.

### Important

Use Baronesse genuine parts for replacement and accessories.  
Our product warranty may be void if you use non-genuine parts for replacement or accessories.

## Adjustment and Replacement

### Adjustment of Brake

### Caution

If the brake wire is cut, the machine will be unable to stop.  
If the brake wire is cracked or damaged, replace it with a new one immediately.

### Caution

If the brake is not sufficiently effective when it has been applied, adjust the brake wire.

1. Adjust the brake by use of the brake wire adjusting nut.

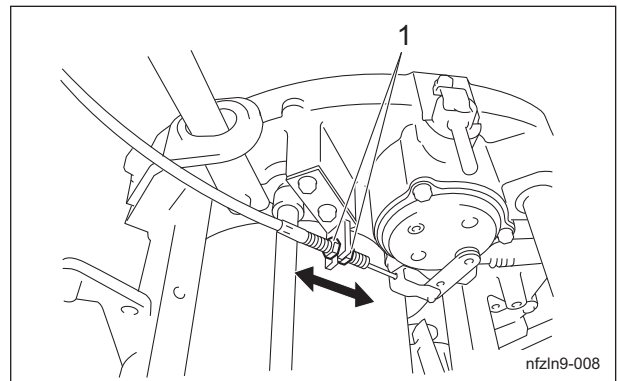

Adjustment of Brake\_001

1	Adjusting nut
---	---------------

2. Make sure that the brake shoe does not touch the brake drum.  
Avoid the brake always being engaged.  
Note:  
The brake shoe may touch the brake drum if you hear a rubbing sound or the drum feels heavy when rotating the drum.
3. Make sure that the brake lever is locked when gripping the lock lever while gripping the brake lever.

### Adjustment of Engine Clutch Section

For centering adjustment of the engine clutch :  
Centering adjustment of the engine clutch is required after replacement of the engine or clutch parts.

1. Adjust the engine clutch.
2. Adjust the clutch wire.
3. Adjust the clutch spring.

For clearance adjustment of the engine clutch :  
Clearance adjustment of the engine clutch is required after replacement of the clutch wire or when the clutch slips.

1. Adjust the clutch wire.
2. Adjust the clutch spring.

## Adjustment of Engine Clutch

Adjust the clearance between the engine clutch and clutch facing so that it will be 0.5 - 1.0 mm (0.020 - 0.039 in) when the main clutch lever set to the "ON" position.

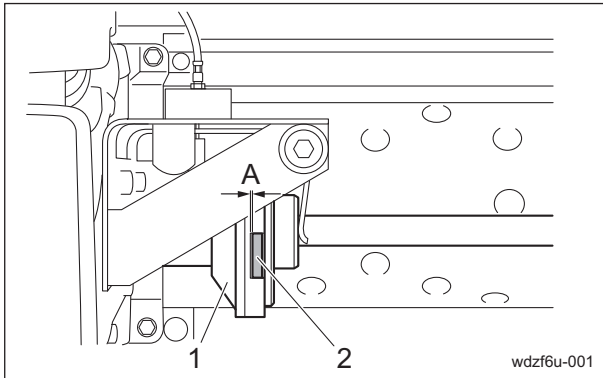

Adjustment of Engine Clutch\_001

1	Engine clutch
2	Clutch facing
A	0.5 - 1.0 mm (0.020 - 0.039 in)

1. Loosen the four bolts A securing the engine.  
Be sure not to loosen the bolts B.
2. Insert a thickness gauge (accessory tool) between the engine clutch and the clutch facing.  
Make adjustment of the engine position so that the front and rear clearances will be the same distance, and then tighten the bolts A.

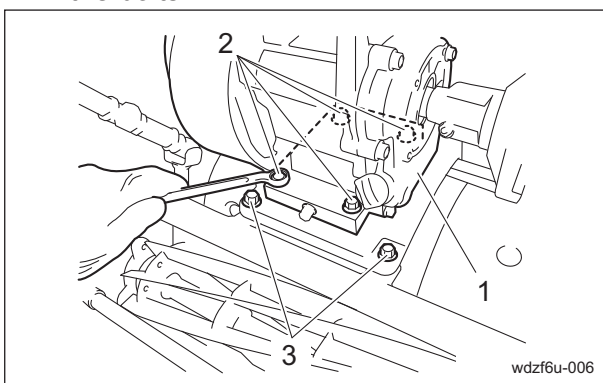

Adjustment of Engine Clutch\_002

1	Engine
2	Bolt A
3	Bolt B

## Adjustment of Clutch Wire

### Important

Make sure that the wire is not cracked or damaged.  
If the wire is cracked or damaged, replace it with a new one immediately.

### Important

Due to frequent use, movement of the lever will become dull, play of the inner wire will change and the inner wire will be stretched depending on R angle of the outer wire. Inspect them and, if necessary, implement adjustment.

Make adjustment of the clutch wire so that the operation distance of the clutch plate between "ON" and "OFF" positions of the main clutch lever will be 1.0 - 2.0 mm (0.039 - 0.079 in).

1. Loosen the clutch wire adjusting nuts.
2. Adjust the operation distance of the clutch plate by changing the clutch wire position.
3. After appropriate adjustment of the operation distance of the clutch plate completed, tighten the clutch wire adjusting nuts.

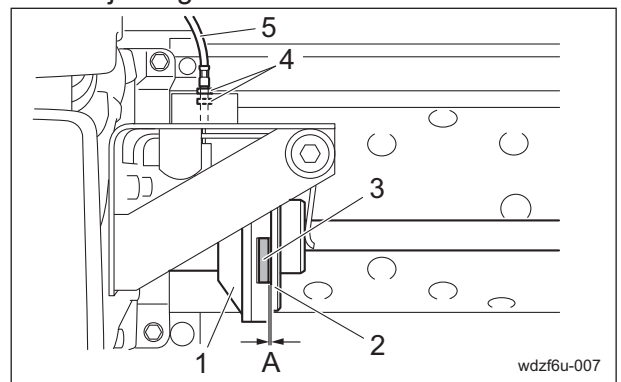

Adjustment of Clutch Wire\_001

1	Engine clutch
2	Clutch plate
3	Clutch facing
4	Clutch wire adjusting nut
5	Clutch wire
A	1.0 - 2.0 mm (0.039 - 0.079 in)

# Repair

## Adjustment of Clutch Spring

The factory default setting of the clutch spring total length is 63.0 mm (2.48 in). The longer the spring is set, the lighter clutch handling is provided. The shorter, the heavier.

1. Make adjustment with the spring adjustment nut so that the total length of the clutch spring will be 63.0 mm (2.48 in) when the main clutch lever set to the "ON" position.
2. Loosen the lock nut and adjust the clutch spring total length with the spring adjustment nut.
3. Confirm that there is no engine clutch slipping when the main clutch lever set to the "ON" position.
4. Tighten the lock nut.

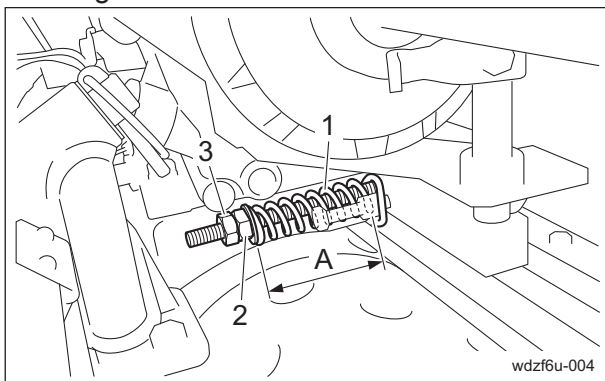

Adjustment of Clutch Spring\_001

1	Clutch spring
2	Spring adjustment nut
3	Lock nut
A	63.0 mm (2.48 in)



**Tightening Torques ..... Page 8-2**

Standard Tightening Torques ..... Page 8-2

Principal Tightening Torques ..... Page 8-4

**Maintenance Schedule ..... Page 8-5****List of Adjusted Values ..... Page 8-7****Troubleshooting Procedures of  
Aftercut Appearance ..... Page 8-8**

Scalping ..... Page 8-8

Angled Mismatch ..... Page 8-8

Overlap Marks ..... Page 8-9

Blade Does Not Cut ..... Page 8-10

Uneven Blade Engagement ..... Page 8-11

# Appended Table

---

## Tightening Torques

**Important**

Refer to the Tightening Torque table.  
Note that the Baroness product warranty may not apply to defects caused by incorrect or overtorque tightening, etc.

## Standard Tightening Torques

### Bolts and Nuts



**Important**

A number of bolts are used in each part of this machine.  
Be sure to re-tighten the bolts and nuts, because they may be loosened at the earlier stage of the use.

- As to the bolts and nuts without any special instruction, tighten them in appropriate tightening torque with proper tool.  
Too much tightening may cause the looseness or damage of the screw.
- The strength of tightening is determined by types of screws, strength, the friction of thread face or base face and others.  
The table below is for the galvanized or parkerized bolts.  
In case that the strength of internal thread is weak, it is not applied.
- Do not use rusty or sand attached "screw."  
Otherwise, it may cause insufficient tightening even if you apply the specified tightening torque.  
The friction of the screw face becomes higher and the tightening torque is canceled out by the friction, therefore sufficient tightening cannot be applied.
- If "screw" is wet by water or oil, do not tighten it with normal tightening torque.  
If the screw is wet, the torque coefficient will get smaller and it may result in too much tightening.  
Too much tightening may cause looseness by the screw stretched or result in damage.
- Do not use a bolt experienced too much burden.
- Using the impact wrench requires the skill.  
Do exercise as much as possible for steady tightening.

## Appended Table

Nominal diameter	General bolt		
	Strength classification 4.8		
	 tib3yb-001		
	N-m	kgf-cm	lb-in
M5	3 - 5	30.59 - 50.99	26.55 - 44.26
M6	7 - 9	71.38 - 91.77	61.96 - 79.66
M8	14 - 19	142.76 - 193.74	123.91 - 168.17
M10	29 - 38	295.71 - 387.49	256.68 - 336.34
M12	52 - 67	530.24 - 683.20	460.25 - 593.02
M14	70 - 94	713.79 - 958.52	619.57 - 831.99
M16	88 - 112	897.34 - 1142.06	778.89 - 991.31
M18	116 - 144	1,182.85 - 1,468.37	1,026.72 - 1,274.54
M20	147 - 183	1,498.96 - 1,866.05	1,301.10 - 1,619.73
M22	295	3,008.12	2,611.05
M24	370	3,772.89	3,274.87
M27	550	5,608.35	4,868.05
M30	740	7,545.78	6,549.74

Nominal diameter	Heat-treated bolt					
	Strength classification 8.8			Strength classification 10.9		
	 tib3yb-002			 tib3yb-003		
	N-m	kgf-cm	lb-in	N-m	kgf-cm	lb-in
M5	5 - 7	50.99 - 71.38	44.26 - 61.96	7 - 10	71.38 - 101.97	61.96 - 88.51
M6	8 - 11	81.58 - 112.17	70.81 - 97.36	14 - 18	142.76 - 183.55	123.91 - 159.32
M8	23 - 29	234.53 - 295.71	203.57 - 256.68	28 - 38	285.52 - 387.49	247.83 - 336.34
M10	45 - 57	458.87 - 581.23	398.30 - 504.51	58 - 76	591.43 - 774.97	513.36 - 672.68
M12	67 - 85	683.20 - 866.75	593.02 - 752.34	104 - 134	1,060.49 - 1,366.40	920.50 - 1186.03
M14	106 - 134	1,080.88 - 1,366.40	938.21 - 1,186.03	140 - 188	1,427.58 - 1,917.04	1,239.14 - 1,663.99
M16	152 - 188	1,549.94 - 1,917.04	1,345.35 - 1,663.99	210 - 260	2,141.37 - 2,651.22	1,858.71 - 2,301.26
M18	200 - 240	2,039.40 - 2,447.28	1,770.20 - 2,124.24	280 - 340	2,855.16 - 3,466.98	2,478.28 - 3,009.34
M20	245 - 295	2,498.27 - 3,008.12	2,168.50 - 2,611.05	370 - 450	3,772.89 - 4,588.65	3,274.87 - 3,982.95
M22	-	-	-	530	5,404.41	4,691.03
M24	-	-	-	670	6,831.99	5,930.17
M27	-	-	-	1,000	10,197.00	8,851.00
M30	-	-	-	1,340	14,628.78	11,860.34

Note:

The same values are applied to "fine screw thread."

# Appended Table

## Principal Tightening Torques

### Tightening Torque by Model

LM18GC/LM56GC/LM66GC/LM66TC

Tighten the following bolts and nuts at the torque specified in the table.

For thread locking adhesive, apply a middle strength thread locker (ThreeBond 1322 or equivalent anaerobic sealant).

Location	Code	Part name	Tightening torque			Thread locking adhesive
			N-m	kgf-cm	lb-in	
Bedknife	K0071000222	SCREW, HT FLAT HEAD M6-12	7 - 9	71.38 - 91.77	61.96 - 79.66	-
Reel shaft	K0185160002	NUT, LEFT-HANDED P1.5 M16-3	36	367.09	318.64	-
Reel shaft (Groomer model)	LM56G--1204Z0	GEAR, 20-TEETH	36	367.09	318.64	-
Front roller	K6083000042	PIN, STEPPED M15-19	29 - 38	295.71 - 387.49	256.68 - 336.34	-
Drum wheel	K001A080251	BOLT, WITH HEX. HOLE M8-25	To keep the fitting from coming off			-
Handle	K0010100252	BOLT, HT M10-25	29 - 38	295.71 - 387.49	256.68 - 336.34	-
Groomer	K0160000602	NUT, SPECIAL P1 M17 WITH M4	5 - 10	50.99 - 101.97	44.26 - 88.51	-
	K6083000143	PIN, STEPPED FOR FIXING (R) CASE	6	61.18	53.11	-

# Appended Table

## Maintenance Schedule

LM18GC/LM56GC/LM66GC/LM66TC

Follow the maintenance schedule below.

● · · · Inspect, adjust, supply, clean (first time)

○ · · · Inspect, adjust, supply, clean

▲ · · · Replace (first time)

△ · · · Replace

Maintenance Item		Before Work	After Work	Every 10 hrs.	Every 25 hrs.	Every 50 hrs.	Every 100 hrs.	Every 300 hrs.	Every 500 hrs.	Every year	Every 2 years	When Required	Remarks
Engine	*2	Check bolts and nuts	○										
	*2	Check fuel	○										
		Check liquid leakage	○										
	*2	Check engine oil	○										
	*2	Check air cleaner		○									
		Clean engine and circumference of the muffler cover		○									
	*2	Replace engine oil				▲		△					
	*2	Check spark plug						○					
	*2	Clean spark arrester						○					
	*2	Clean sediment cup						○					
	*1	Clean fuel tank & filter						○					
	*1	Check idling speed							○		○		Every 300 hours or every year whichever comes earlier
	*1	Check valve clearance							○		○		Every 300 hours or every year whichever comes earlier
	*2	Replace air cleaner							△		△		Paper filter element: Every 300 hours or every year whichever comes earlier Foam filter element: As necessary
	*2	Replace spark plug							△		△		Every 300 hours or every year whichever comes earlier
	*1	Remove carbon in combustion chamber								○			
*1	Check fuel hoses and clamp bands										○	△	

# Appended Table

Maintenance Item		Before Work	After Work	Every 10 hrs.	Every 25 hrs.	Every 50 hrs.	Every 100 hrs.	Every 300 hrs.	Every 500 hrs.	Every year	Every 2 years	When Required	Remarks
Driving section	Check tire	○											
	Check damaged parts	○											
	Check bolts and nuts	○											
	Check main clutch lever	○											
	Check brake	○											
	Check work lamp illumination	○											
	Adjust handle position	○											
	Check safety lock of main clutch	○											
	Check cover	○											
	Clean driving section		○										
	Grease and Lubricate all moving parts			○		○							Maintenance schedules differ according to greasing points
	Adjust engine clutch spring											○	
	Check brake wire						○					△	
	Check electrical wiring									○			
	Adjust engine clutch gap											○	
Check throttle wire											○		
Check main clutch wire											○		
Cutting section	Check blade (Reel cutter and Bedknife)	○											
	Check cover	○											
	Check roller	○											
	Check groomer	○											
	Check blade engagement	○											
	Check mowing height	○											
	Adjust groomer	○											
	Check damaged parts	○											
	Check bolts and nuts	○											
	Clean cutting section		○										
	Grease			○		○							Maintenance schedules differ according to greasing points
	Clean and Grease Bedknife Eccentric Bushes								○	○			Every 500 hours or every year whichever comes earlier, and when replacing a bedknife additionally.
Replace bearings inside gearcase										△			
Replace front/rear roller bearings										△			

# Appended Table

Maintenance Item		Before Work	After Work	Every 10 hrs.	Every 25 hrs.	Every 50 hrs.	Every 100 hrs.	Every 300 hrs.	Every 500 hrs.	Every year	Every 2 years	When Required	Remarks
Cutting section	Replace grass catcher roller bearings									△			
	Replace oil seals inside gearcase									△			
	Replace front/rear roller oil seals									△			
	Replace grass catcher roller oil seals									△			
	Replace grease inside gearcase									△			
	Adjust cutter adjustment spring											○	
	Engage blades											○	
	Adjust mowing height											○	
	Backlap blades											○	
	Regrind blades (Reel cutter)											○	Grind/Replace blades as and when required

- \*1: Consult your local Baroness Dealer for this service.
- \*2: Refer to the Engine's Owner's Manual.
- The values for consumables are not guaranteed.

## List of Adjusted Values

Cutter adjustment spring	50.0 mm (1.97 in)	Length of coil spring
Reel cutter shaft bearing preload spring	11.5 mm (0.453 in)	Total length of spring
Reel cutter rotation torque	0.8 - 1.0 N • m (8 - 10 kgf • cm)	
Engine clutch	0.5 - 1.0 mm (0.020 - 0.039 in)	Gap between engine clutch and clutch facing
Operation distance of clutch plate	1.0 - 2.0 mm (0.039 - 0.079 in)	
Engine clutch spring	63.0 mm (2.48 in)	Total length of spring

# Appended Table

## Troubleshooting Procedures of Aftercut Appearance

### Scalping

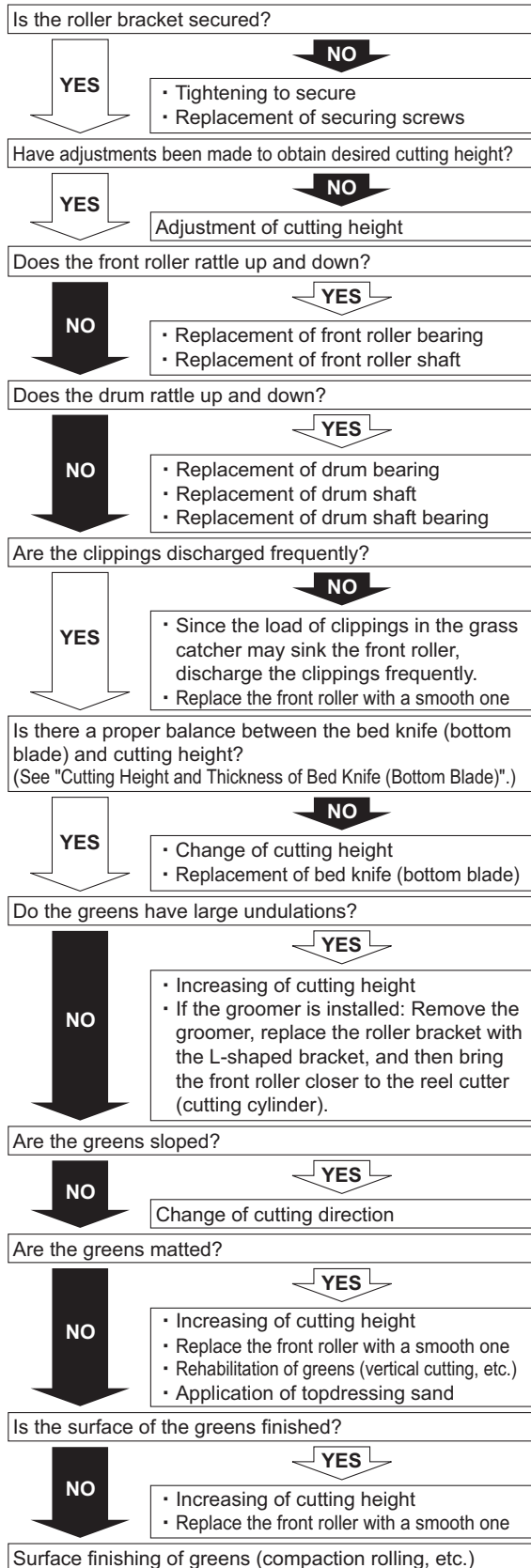

iuwt3m-004E

Scalping\_001

### Angled Mismatch

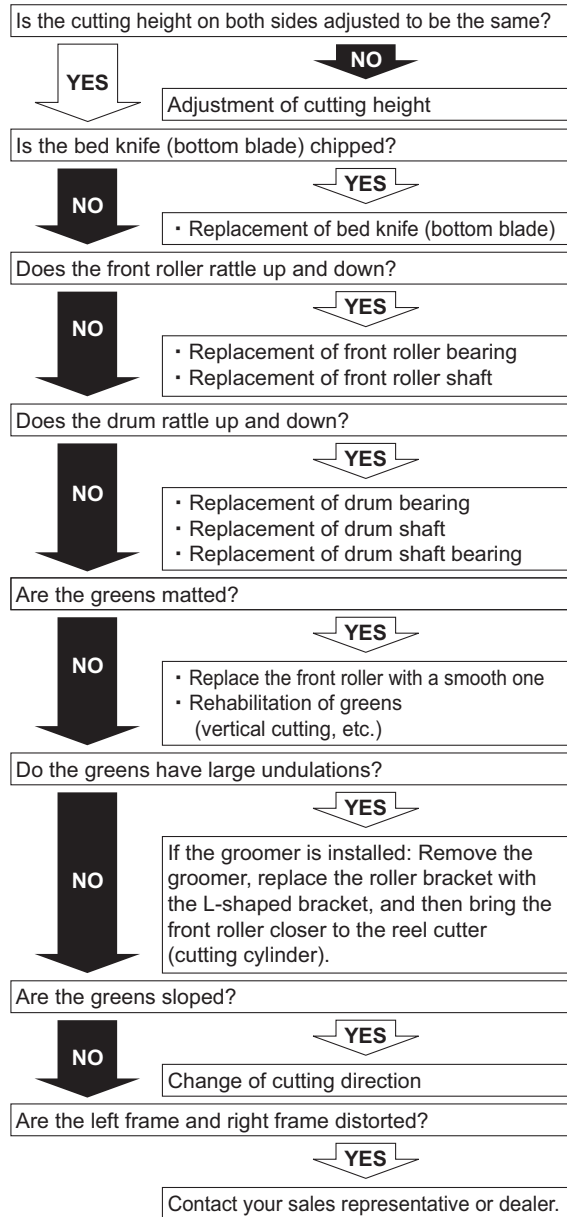

7x9s4e-001E

Angled Mismatch\_001



## Overlap Marks

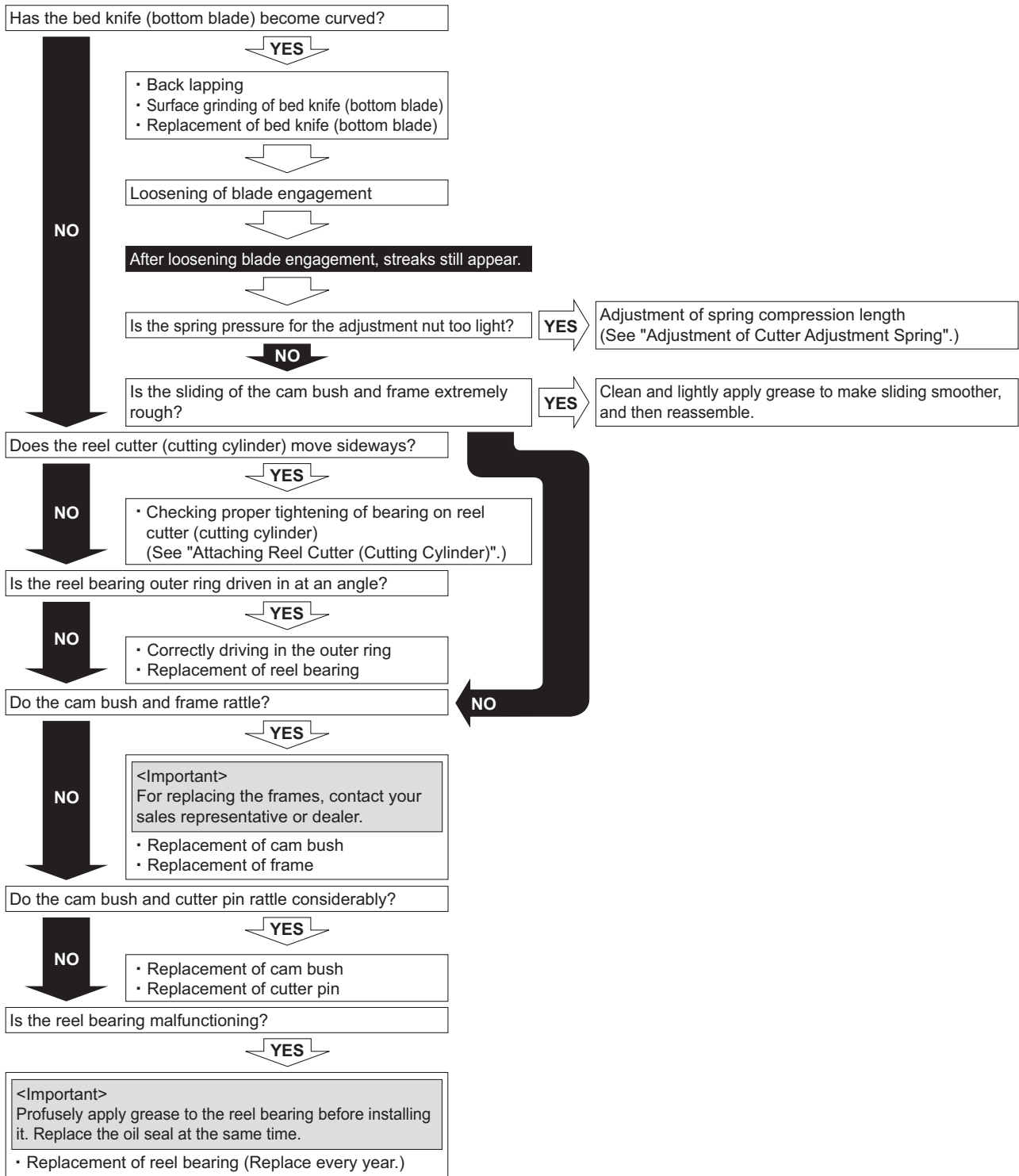

# Appended Table

## Blade Does Not Cut

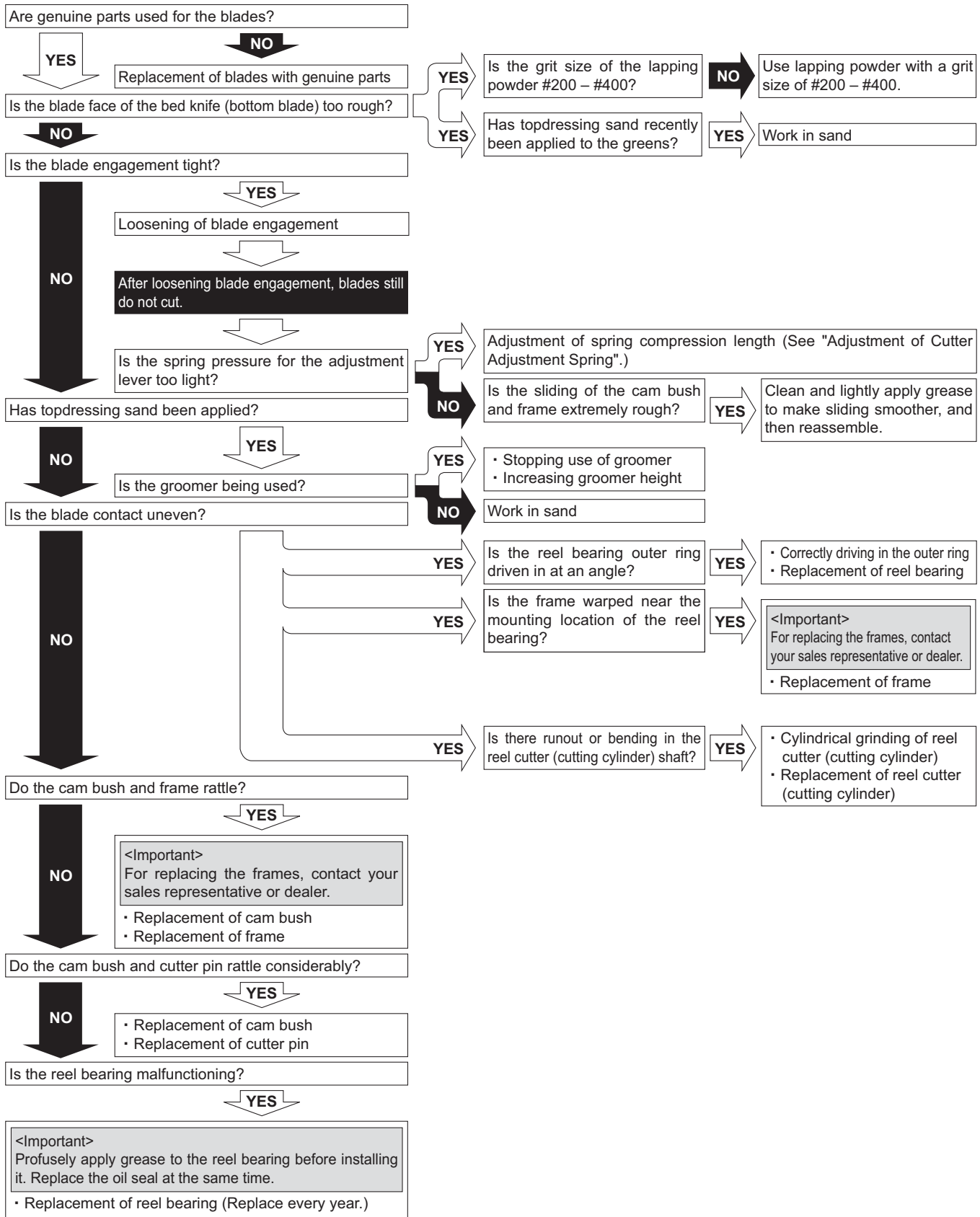

t3iz9v-002E

## Uneven Blade Engagement

The unevenness is a difference of tightening torque between the left and right cutter adjustment nuts, or blade engagement on only one side, which cannot be adjusted.

Promptly resolve the issue in order to maintain the optimum performance of the machine.

Cause of unevenness	Measure to resolve
Asymmetrical wear of reel cutter (cutting cylinder)	Cylindrical grinding of reel cutter (cutting cylinder) Replacement of reel cutter (cutting cylinder)
Asymmetrical wear of bed knife (bottom blade)	Surface grinding of bed knife (bottom blade) Replacement of bed knife (bottom blade)
Distortion of frames	Rearrange frames in parallel

### Important

Depending on the extent of the symptoms, they may not be resolved.

### Important

Performing temporary measures may cause the symptoms to progress, resulting in cutting issues.

Temporary measures:

- Adjustment with cam bushes  
"Adjusting CAM" (Page 6-12)
- Adjustment of spring pressure  
"Adjustment of Cutter Adjustment Spring" (Page 6-11)

## Appended Table

---

**BARONESS**<sup>®</sup>  
Quality on Demand

 **KYOEISHA CO., LTD.**  
Head Office 1-26, Miyuki-cho, Toyokawa-city, Tel :+81-533-84-1390  
Aichi-pref, 442-8530 JAPAN Fax:+81-533-84-1220