

LM551A

5-Unit Reel Mower

Owner's Operating Manual

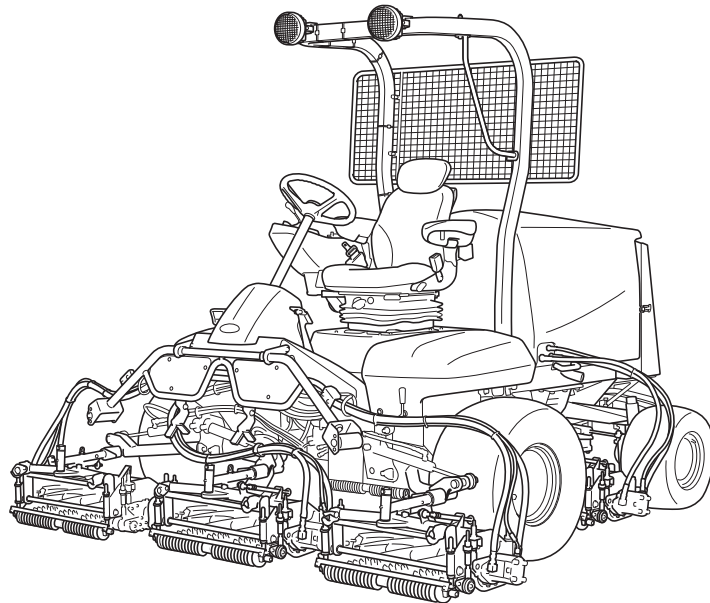

Serial No. LM551A : 20043-

"Required reading"

Read this manual and the Owner's Manual for the engine before using the machine.

BARONESS[®]
Quality on Demand

Ver.1.1

Regulations

California Proposition 65

(For California, USA)

⚠ WARNING:

Operating, servicing and maintaining a passenger vehicle or off-road vehicle can expose you to chemicals including engine exhaust, carbon monoxide, phthalates, and lead, which are known to the State of California to cause cancer and birth defects or other reproductive harm. To minimize exposure, avoid breathing exhaust, do not idle the engine except as necessary, service your vehicle in a well-ventilated area and wear gloves or wash your hands frequently when servicing your vehicle. For more information go to www.P65Warnings.ca.gov/passenger-vehicle.

318yi8-005

California Proposition 65_001

California Spark Arrester

(For California, USA)

⚠ Warning

Operation of this equipment may create sparks that can start fires around dry vegetation.

A spark arrester may be required.

The operator should contact local fire agencies for laws or regulations relating to fire prevention requirements.

The DPF installed on the engine of this machine meets requirements of California Public Resource Code Section 4443.

Thank you for purchasing the Baroness product. This manual describes the proper handling, adjustment, and inspection of your product. We hope you will use the product safely, and take advantage of its best performance. For details on the handling, adjustment and inspection of the attachments, refer to the Owner's Operating Manual for the attachments.

Keeping The Owner's Operating Manual

Keep this Manual in the bag located in the rear of the seat.

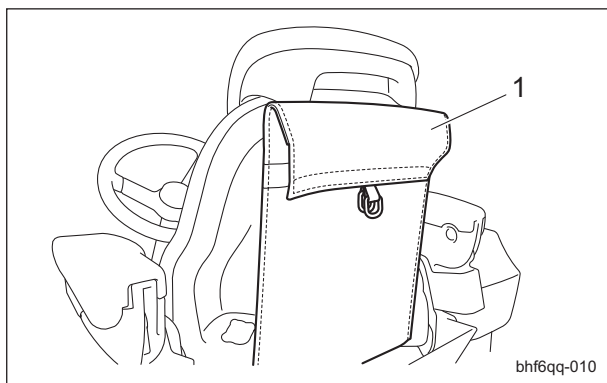

Keeping The Owner's Operating Manual_001

1	Bag
---	-----

Introduction

Read this manual carefully to ensure that you thoroughly understand how to properly operate and maintain the product, and to avoid causing injury to yourself or others.

The operator is responsible for operating the product properly and safely.

Maintenance should only be performed by a certified specialist.

If you have any questions concerning maintenance or genuine parts, please contact your local Baroness dealer or Kyoisha.

When making inquiries about the product, please specify the product's model designation and serial number.

When loaning or transferring the product, please also provide this manual together with the product.

Kyoisha Co., Ltd.

Warning Symbols

This manual uses the following warning symbols for handling precautions that are important for your safety.



696cq5-001

Warning symbol

This symbol indicates the articles regarding “Danger,” “Warning,” or “Caution.”

Those articles describe important safety precautions and so read them carefully to understand completely before operating the machine.

Failure to adequately follow these safety precautions may cause an accident.

Danger

This symbol indicates that serious injury or death will occur if the warning is ignored.

Warning

This symbol indicates that serious injury or death may occur if the warning is ignored.

Caution

This symbol indicates that injury or damage to property may occur if the warning is ignored.

Important

This symbol indicates precautions on the mechanism of the machine.

Precautionary Statement

 Caution

The information described in this manual is subject to change for improvement without prior notice.

When replacing parts, be sure to use genuine Baroness parts or parts designated by Kyoisha.

Note that the Baroness product warranty may not apply to defects caused by the use of parts from other companies.

Prior to use, carefully read the following manuals to thoroughly understand the contents for safe and correct operation.

- Baroness Owner's Operating Manual
- The Engine's Owner's Manual
- The Battery's Owner's Manual

Purpose

This product is intended for cutting turf grass at golf courses.

Do not use this product in any way other than its intended purpose, and do not modify this product.

Operating this product for other purposes and modifying it may be very dangerous and may cause damage to the product.

In addition, this product is not authorized for operation as a special motor vehicle. Do not operate it on public roads.

LM551A

Introduction

Safety	Page 1-1
Safe Operating Practices	Page 1-2
Disposal	Page 2-1
Recycle and Waste Disposal	Page 2-2
Product Overview	Page 3-1
Specifications	Page 3-2
Names of Each Section	Page 3-4
Regulation Decals	Page 3-4
Safety Signs and Instruction Signs	Page 3-7
Handling Instructions	Page 4-1
Inspection Before Use	Page 4-2
Tightening Torques	Page 4-15
Adjustment Before Operating	Page 4-18
Procedure to Start / Stop Engine	Page 4-22
Operation of Each Section	Page 4-25
Instruments	Page 4-40
Travel of Machine	Page 4-68
Cutting Work	Page 4-69
Transporting	Page 4-70
Long-Term Storage	Page 4-70
Maintenance	Page 5-1
Maintenance Precautions	Page 5-2
Maintenance Schedule	Page 5-2
DPF	Page 5-8
Jacking Up The Machine	Page 5-18
Greasing	Page 5-20
Lubrication	Page 5-24
Maintenance Work	Page 5-26

LM551A

Contents

Safe Operating Practices Page 1-2

Training Page 1-2

Preparation Page 1-2

Operation Page 1-3

Maintenance and Storage Page 1-4



Safety

Failure to adequately follow these safety precautions may cause an accident resulting in injury or death.

Danger

This product is designed to ensure safe operation and has been tested and inspected thoroughly before shipment from the factory. The product is equipped with safety devices to prevent accidents.

However, whether the product demonstrates its original performance level depends on the manner in which it is operated and handled, as well as the manner in which it is managed on a daily basis.

Inappropriate use or management of the product may result in injury or death.

Observe the following safety instructions to ensure safe operation.

Safe Operating Practices

Training

1. Read this manual and other training material carefully. Be familiar with the controls, safety signs, and the proper use of the equipment.

2. If the operator or mechanic can not read English it is the owner's responsibility to explain this manual to them.

3. All operators and mechanics should seek and obtain professional and practical instruction.

The owner is responsible for training the users.

Such instruction should emphasize.

[1] The need for care and concentration when working with ride-on machines.

[2] Control of a ride-on machine sliding on a slope will not be regained by the application of the brake.

The main reasons for loss of control are

- Insufficient wheel grip
- Being driven too fast
- Inadequate braking
- The type of machine is unsuitable for its task
- Lack of awareness of the effect of ground conditions, especially slopes
- Incorrect hitching and load distribution

4. Never allow children or people unfamiliar with these instructions to use or service the machine.

Local regulations may restrict the age of the operator.

5. The owner/user can prevent and is responsible for accidents or injuries occurring to themselves, other people, or property.

6. Keep in mind that the owner, operator, and mechanic are responsible for accidents or hazards occurring to other people or their property.

7. The ROPS is an integral and effective safety device.

Do not remove or alter the ROPS.

8. Replace a damaged ROPS.

Do not repair or alter.

9. You can find additional safety information where needed throughout this manual.

10. Determine the left and right sides of the machine from the normal operating position.

Preparation

1. Evaluate the terrain to determine what accessories and attachments are needed to properly and safely perform the job. Only use accessories and attachments approved by the manufacturer.

2. While operating, always wear substantial footwear, long trousers, hard hat, safety glasses, and ear protection. Long hair, loose clothing, or jewelry may get tangled in moving parts. Do not operate the equipment when barefoot or wearing open sandals.

3. Inspect the area where the equipment is to be used and remove all objects such as rocks, toys and wire which can be thrown by the machine.

4. Keep children out of the operating area and under the watchful care of a responsible adult other than the operator.

5. Exercise care in the handling of fuel.

Warning

Warning-Fuel is highly flammable. Take the following precautions.

[1] Store fuel in containers specifically designed for this purpose.

- [2] Add fuel before starting the engine. Never remove the cap of the fuel tank or add fuel while the engine is running or when the engine is hot.
- [3] Refuel outdoors only and do not smoke while refueling.
- [4] If fuel is spilled, do not attempt to start the engine but move the machine away from the area of spillage and avoid creating any source of ignition until petrol vapours have dissipated.
- [5] Replace all fuel tanks and container caps securely.
6. Check that operator's presence controls, safety switches and shields are attached and functioning properly. Do not operate unless they are functioning properly.
7. If the brake operation is faulty or the parking brake lever has noticeable play, be sure to adjust or repair them before operating the machine.
8. Replace faulty mufflers.
9. On multi-cylinder/multi-reel machines take care as rotating one cylinder/reel can cause other cylinder/reels to rotate.
- [5] Never operate across the face of the slope, unless the machine is designed for this purpose.
- [6] Never drive the machine on a slope with an angle of gradient that is greater than that specified or in a place where there is a danger of the machine slipping.
5. Use extra care while operating machine with a grass catcher or other attachments. They can affect the stability of the machine.
6. Never operate the machine with damaged guards, shields, or without safety protective devices in place. Be sure all interlocks are attached, adjusted and functioning properly.
7. Do not change the engine governor settings or overspeed the engine. Operating the engine at excessive speed may increase the hazard of personal injury.
8. Do the following before leaving the operator`s position.
 - [1] Stop on level ground.
 - [2] Disengage the power take-off and lower the attachments.
 - [3] Change into neutral and set the parking brake.
 - [4] Stop the engine and remove the key.

Operation

1. Do not operate the engine in a confined space where dangerous carbon monoxide fumes can collect.
2. Only operate in good light, keeping away from holes and hidden hazards.
3. Before attempting to start the engine, disengage all attachments, shift into neutral, and engage the parking brake. Only start engine from the operator`s position. Use seat belts if provided.
4. Remember there is no such thing as a safe slope. Travel on grass slopes requires particular care. To guard against overturning:
 - [1] Do not stop or start suddenly when going up or downhill.
 - [2] Engage clutch slowly, always keep machine in gear, especially when traveling downhill.
 - [3] Machine speeds should be kept low on slopes and during tight turns.
 - [4] Stay alert for humps and hollows and other hidden hazards.
9. Disengage the drive to attachments, stop the engine, and remove the ignition key in the following conditions.
 - [1] Before refueling.
 - [2] Before removing the grass catcher/ catchers.
 - [3] Before making height adjustment unless adjustment can be made from the operator's position.
 - [4] Before cleaning blockages.
 - [5] Before checking, cleaning, or working the machine.
 - [6] After striking a foreign object or if an abnormal vibration occurs. Inspect the machine for damage and make repairs before restarting and operating the equipment.
10. Keep hands and feet away from the cutting units and the rotating parts.
11. Do not mow in reverse unless absolutely necessary. Always look down and behind before and while backing.
12. Do not carry passengers.

Safety

13. Never operate while people, especially children, or pets are nearby.
14. Slow down and use caution when making turns and crossing roads and sidewalks.
15. Stop the blades rotating before crossing surfaces other than grass.
16. Disengage drive to attachments when transporting or not in use.
17. When using any attachments, never direct discharge of material toward bystanders nor allow anyone near the machine while in operation.
18. Do not operate the machine under the influence of alcohol or drugs.
19. Take care when loading or unloading the machine into a trailer or a truck. Load or unload the machine in a flat and safe place. Before loading or unloading, set the parking brake on the truck or trailer, stop the engine, and chock the wheels.
When transporting the machine on a truck or a trailer, set the parking brake, stop the engine, and fasten the machine to the truck with a rope or other suitable restraining device that has sufficient strength.
When using a loading ramp, select one with sufficient strength, length, and width and that will not cause the machine to slip.
20. Close the fuel valve before transporting the machine.
21. Use care when approaching blind corners, shrubs, trees, or other objects that may obscure vision.
22. Do not take your eyes off the road ahead. Do not operate the machine with no hands.
23. Reduce the throttle setting during engine run-out and, if the engine is provided with a shut-off valve, turn the fuel off at the conclusion of operation.
24. Do not operate the machine when there is the risk of lightning.
3. To reduce the fire hazard, keep the engine, silencer/muffler, battery compartment fuel storage area, cutting unit and drives free of grass, leaves, or excessive grease. Clean up oil or fuel spillage.
4. Allow the engine to cool before storing in any enclosure.
5. Only cover the machine with a sheet after hot parts have sufficiently cooled down.
6. Never store the equipment with fuel in the tank inside a building where fumes may reach an open flame or spark.
7. If the engine is provided with a shut-off valve, shut off valve while storing or transporting.
8. Do not store fuel near flames.
9. Never allow untrained personnel to service machine.
10. Allow the engine/muffler to cool before checking/maintenance.
11. Appropriately manage and correctly use the tools necessary for servicing or adjusting the machine.
12. Use jack stands to support components when required.
13. Carefully release pressure from components with stored energy.
14. Be sure to depressurize the hydraulic system before performing maintenance operations on it such as removing hydraulic equipment.
15. Check whether line connectors in the hydraulic system are properly tightened. Before applying hydraulic pressure, check the connections of the hydraulic pressure lines and the condition of the hoses.
16. When checking the hydraulic circuit for pinhole leaks or oil leakage from nozzles, do not use your hands. Use items such as paper or corrugated cardboard to find leakage points. Be extremely careful with high-pressure oil as it may pierce your skin, resulting in an injury.
If fluid is injected into the skin it must be surgically removed within a few hours by a doctor familiar with this form of injury or gangrene may result.
17. Disconnect battery before making any repairs. Disconnect the negative terminal first and the positive last. Reconnect positive first and negative last.

Maintenance and Storage

1. Disengage drives on level ground, lower the attachments, set parking brake, stop engine and remove key from ignition. Wait for all movement to stop before adjusting, cleaning or repairing.
2. When machine is to be parked, stored, or left unattended, lower the cutting units unless a positive mechanical lock is provided.

18. Make sure that parts such as wires are not touching each other and that their covers have not come off.
19. Use care when checking the cylinders/reels and bed knives.
 - [1] Wear gloves and use caution when servicing them.
 - [2] Be careful during adjustment of the machine to prevent entrapment of the fingers between moving blades and fixed parts of the machine.
20. On multi-cylinder/multi-reel machines take care as rotating one cylinder/reel can cause other cylinder/reels to rotate.
21. Keep hands and feet away from moving parts. If possible, do not make adjustments with the engine running.
22. Charge batteries in an open well ventilated area, away from spark and flames. Unplug charger before connecting or disconnecting from battery. Wear protective clothing and use insulated tools.
23. Keep all parts in good working condition and all hardware tightened. Replace all worn or damaged decals.
24. Keep all nuts, bolts and screws tight to be sure the equipment is in safe working condition.
25. Check the grass catcher frequently for wear or deterioration.
26. If the fuel tank has to be drained, do this outdoors.
27. Swallowing engine coolant can cause injury or death; keep out of reach from children and pets.

Recycle and Waste Disposal Page 2-2

About RecyclePage 2-2

About The Waste Disposal Page 2-2

Disposal

Disposal

Recycle and Waste Disposal

About Recycle

Recycling battery etc. is recommended for environmental conservation and economical use of resources.

It may be required by local laws.

About The Waste Disposal

Make sure that waste generated when servicing or repairing the machine is disposed of in accordance with local regulations. (e.g. waste oil, antifreeze, rubber products, and wires etc.)

Specifications	Page 3-2
Specifications	Page 3-2
Sound Pressure Level	Page 3-3
Sound Power Level	Page 3-3
Vibration Level	Page 3-3
Names of Each Section	Page 3-4
Regulation Decals	Page 3-4
Positions of Regulation Decals	Page 3-4
Description of Regulation Decals	Page 3-5
Safety Signs and Instruction Signs	Page 3-7
About Safety Signs and Instruction Signs	Page 3-7
Positions of Safety Decals and Instruction Decals	Page 3-7
Description of Safety Decals and Instruction Decals	Page 3-8

Product Overview

Specifications

Specifications

Model		LM551A					
Mower unit type		22 in			26 in		
Dimensions	Total length		116.14 in	295 cm	←	←	
	Total width		86.61 in	220 cm	←	←	
	Total height	Roof	94.09 in	239 cm	←	←	
		Handle	62.99 in	160 cm	←	←	
Weight	Machine (empty fuel tank)	LH52	with Groomer, CR brush, ROPS, Light and Ball proof net without Grass catcher	3238.59 lb	1469 kg	-	-
		LH62	with Groomer, CR brush, ROPS, Light and Ball proof net without Grass catcher	3439.21 lb	1560 kg	-	-
		LS62 • 66	with CR brush, ROPS, Light and Ball proof net without Grass catcher	3304.73 lb	1499 kg	3334.80 lb	1514 kg
	Grass catcher (for one machine)		10.14 lb	4.6 kg	-	-	
	Minimum turning radius		LH52	Front wheel (outer wheel) outside	120.47 in	306 cm	-
			Outer side of unit	136.61 in	347 cm	-	-
		LH62	Front wheel (outer wheel) outside	120.47 in	306 cm	-	-
				Outer side of unit	136.61 in	347 cm	-
		LS62 • 66	Front wheel (outer wheel) outside	120.47 in	306 cm	←	←
				Outer side of unit	135.83 in	345 cm	139.37 in
Engine	Model		Kubota V1505-T-E4B			←	
	Type		Vertical water-cooled 4-cycle diesel engine			←	
	Total displacement		91.41 cu.in.	1498 cm ³ (1.498 L)	←	←	
	Maximum output		33.0 kW (44.9 PS)/3000rpm			←	
Fuel tank capacity		Diesel 13.47 U.S.gals	Diesel 51.0 dm ³ (51.0 L)	←	←		
Fuel consumption		211.0 g/PS • h (rated output)	287 g/kW • h (rated output)	←	←		
Engine oil capacity		1.59 U.S.gals	6.0 dm ³ (6.0 L)	←	←		

Product Overview

Coolant volume		2.64 U.S.gals	10.0 dm ³ (10.0 L)	←	←
Hydraulic tank capacity		8.01 U.S.gals	30.3 dm ³ (30.3 L)	←	←
Operating width (Mowing width)		100.00 in	254 cm	111.02 in	282 cm
Operating height (Mowing height)	LH52	0.197 - 0.787 in	5.0 - 20.0 mm	←	←
	LH62	0.315 - 1.772 in	8.0 - 45.0 mm	-	-
	LS62 • 66	0.394 - 1.811 in	10.0 - 46.0 mm	←	←
Drive	Traveling	HST (Full time 4WD)		←	
	Mowing	Hydraulic (Gear motor drive)		←	
Speed (HST)	Forward	9.94 mph	16.0 km/h	←	←
	Reverse	4.97 mph	8.0 km/h	←	←
Speed (Mechanical)		-		-	
Efficiency		6.03 acres/ hour (7.46 mph x mowing width x 0.8)	24,384 m ² /h (12.0 km/h x mowing width x 0.8)	6.69 acres/ hour (7.46 mph x mowing width x 0.8)	27,072 m ² /h (12.0 km/h x mowing width x 0.8)
Maximum inclination for operation		15 degrees		←	
Tire size	Front wheel	26.5 x 14.00-12		←	
	Rear wheel	20 x 12.00-10		←	
Tire pneumatic pressure	Front wheel	17.40 psi	120 kPa (1.2 kgf/cm ²)	←	←
	Rear wheel	20.30 psi	140 kPa (1.4 kgf/cm ²)	←	←
Battery		105D31L		←	
Engine plug		-		←	

The factory default maximum engine rpm is 3,000 rpm.

Sound Pressure Level

Sound Pressure Level

This machine was confirmed to have a continuous A-weighted sound pressure level of 84 dB by measuring identical machines in accordance with the procedure specified in ISO5395-1:2013.

Sound Power Level

Sound Power Level

This machine was confirmed to have a sound power level of 103 dB by measuring identical machines in accordance with the procedure specified in directive 2000/14/EC.

Vibration Level

Hand-Arm Vibration

This machine was confirmed not to exceed a vibration level of 2.5 m/s² to hands and arms by measuring identical machines in accordance with the procedure specified in ISO 5395-1:2013.

Whole Body Vibration

This machine was confirmed not to exceed a vibration level of 0.5 m/s² to the whole body by measuring identical machines in accordance with the procedure specified in ISO 5395-1:2013.

Product Overview

Names of Each Section

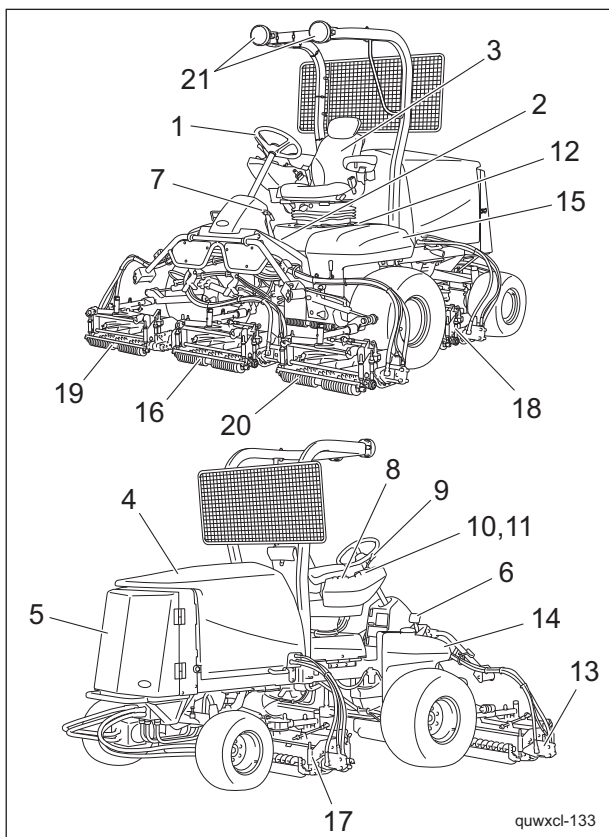

Names of Each Section_001

1	Steering wheel
2	Tilt lever
3	Seat
4	Hood
5	Radiator cover
6	Traveling pedal
7	Brake pedal
8	Throttle knob
9	Mower unit up/down lever
10	Traveling/working selector switch
11	Reel rotation switch
12	Reel forward/reverse switch
13	Reel rotation/stop switching lever
14	Fuel tank
15	Hydraulic tank
16	Mower unit #1
17	Mower unit #2
18	Mower unit #3
19	Mower unit #4
20	Mower unit #5
21	Light

Regulation Decals

Positions of Regulation Decals

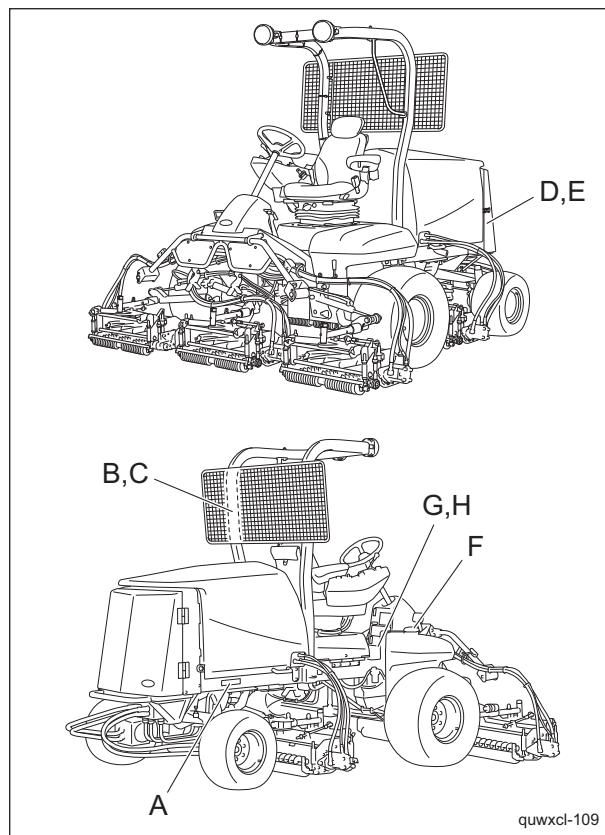

Positions of Regulation Decals_001

A	Serial number plate
B	ROPS compliance decal
C	ROPS caution decal
D	Recycle decal
E	Battery danger decal
F	Diesel instruction mark
G	California Proposition 65 decal (riding type)
H	Spark arrester warning decal

Product Overview

Description of Regulation Decals

Serial Number Plate

The serial number plate indicates the model and serial number of the machine.

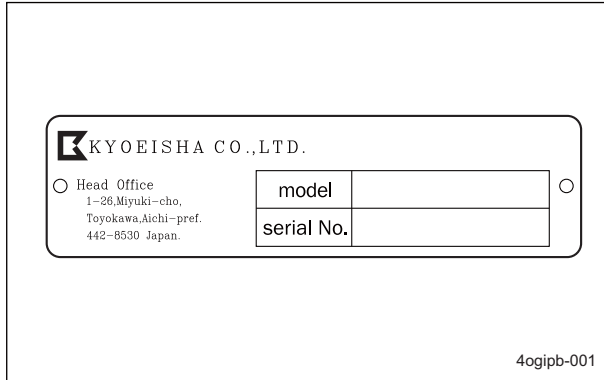

Serial Number Plate_001

ROPS Compliance Decal

The ROPS compliance decal indicates the manufacturer, model, etc., in accordance with International Standard ISO 21299:2009.

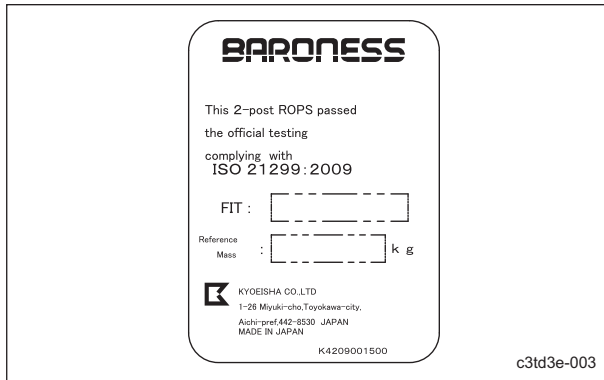

ROPS Compliance Decal_001

ROPS Caution Decal

ROPS caution decal describes the caution messages compliant with ISO 21299:2009. Replace damaged ROPS. Do not repair or revise. (Only if equipped with ROPS)

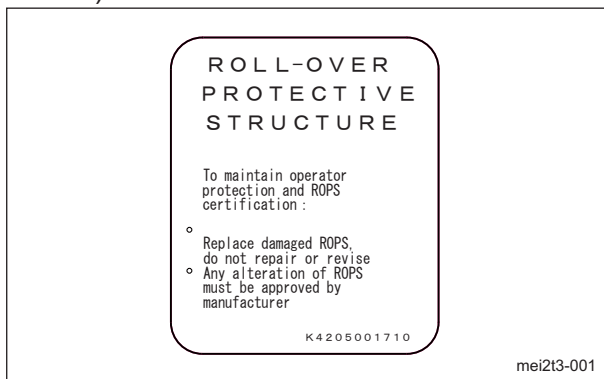

ROPS Caution Decal_001

Recycle Decal

Recycle Decal illustrates Recycle Mark in accordance with local regulation. (For Europe)

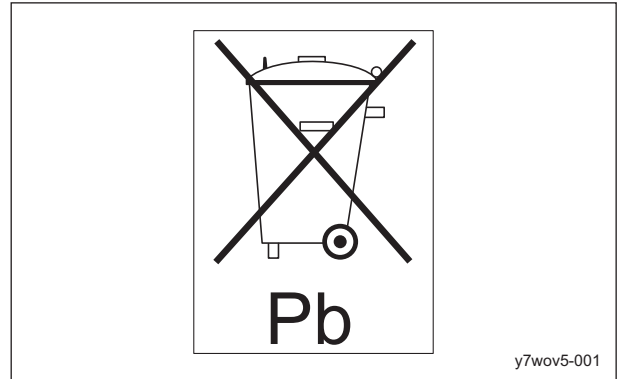

Recycle Decal_001

(For USA)



Recycle Decal_002

Battery Danger Decal

(For USA) Battery Danger Decal describes handling precautions for battery.

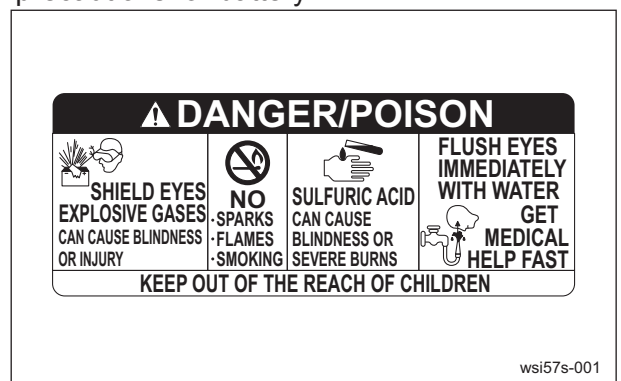

Battery Danger Decal_001

Product Overview

Diesel Instruction Mark

(For USA)
Diesel instruction mark describes the type of fuel to be used.
Use Ultra Low Sulfur Diesel Fuel (sulfur-free diesel).

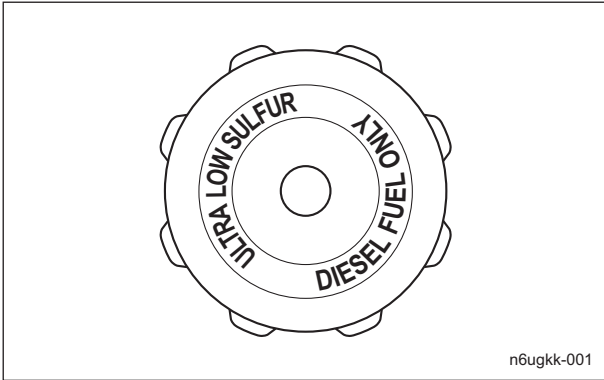

Diesel Instruction Mark_001

Spark Arrester Warning Decal

(For the State of California, USA)
Spark arrester warning decal describes the warning messages as required by California Public Resources Code.

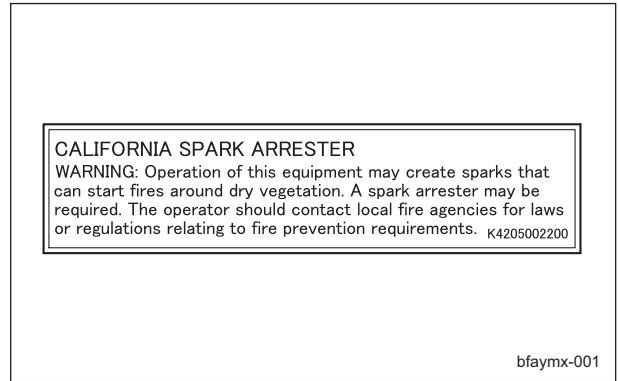

Spark Arrester Warning Decal_001

California Proposition 65 Decal (riding type)

(For the State of California, USA)
California Proposition 65 decal describes the warning messages as required by California Proposition 65.

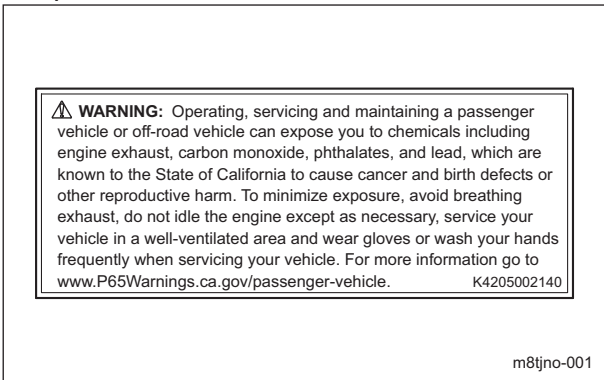

California Proposition 65 Decal (riding type)_001

Safety Signs and Instruction Signs

About Safety Signs and Instruction Signs

Important

Safety decals and instruction decals are attached to this product. Make sure that they are preserved in their entirety. If they are damaged, become dirty, or peel off, replace them with new ones.

Part numbers for decals that need to be replaced are listed in the parts catalog. Order them from a Baroness dealer or Kyoisha.

Positions of Safety Decals and Instruction Decals

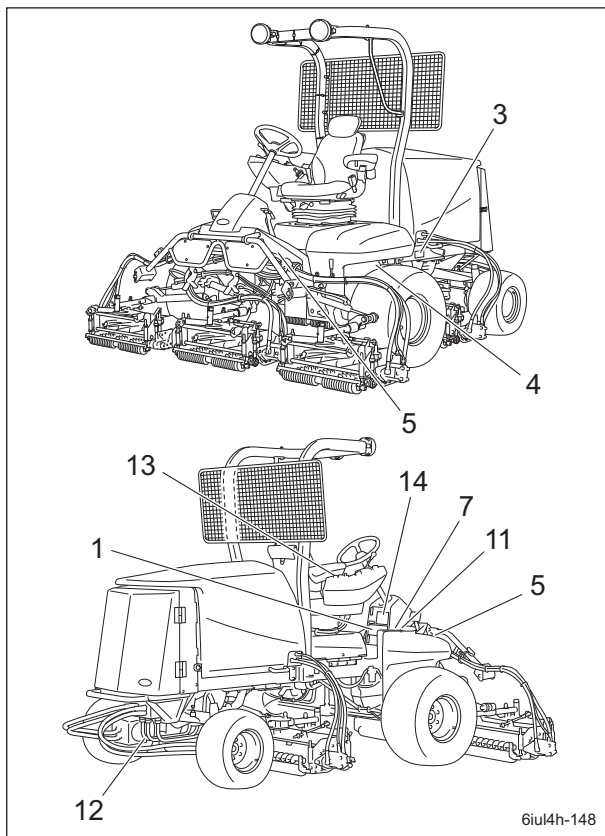

Positions of Safety Decals and Instruction Decals_001

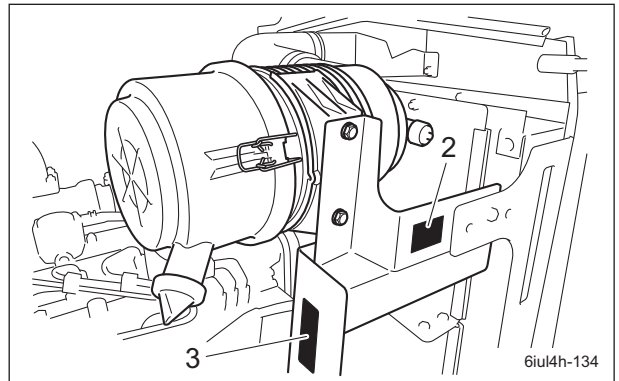

Positions of Safety Decals and Instruction Decals_002

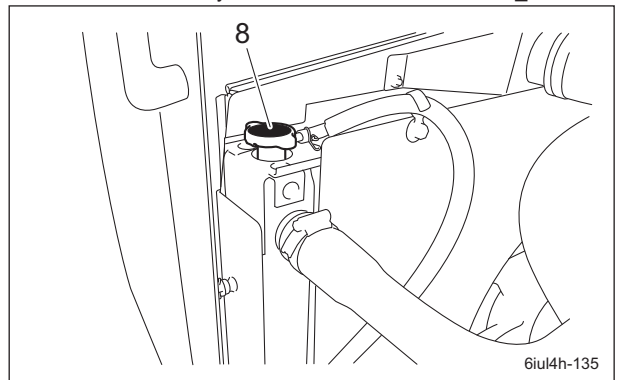

Positions of Safety Decals and Instruction Decals_003

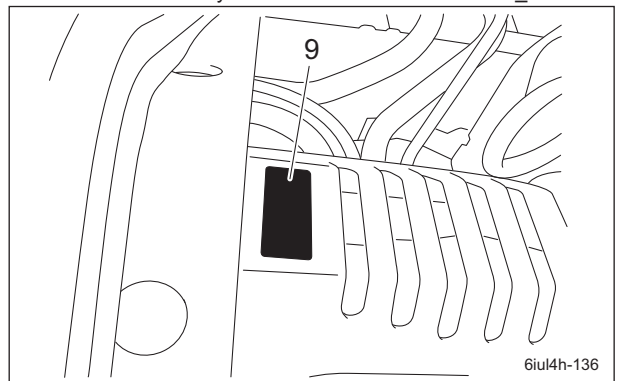

Positions of Safety Decals and Instruction Decals_004

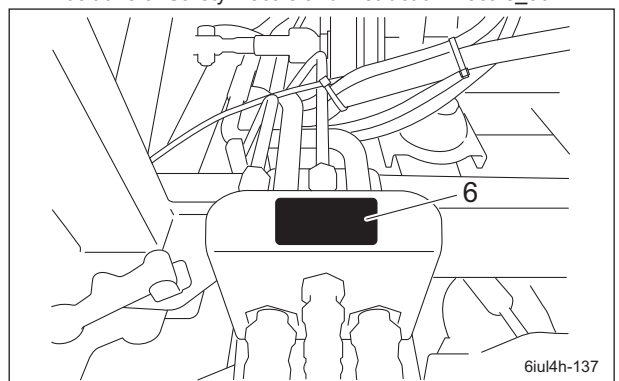

Positions of Safety Decals and Instruction Decals_005

Product Overview

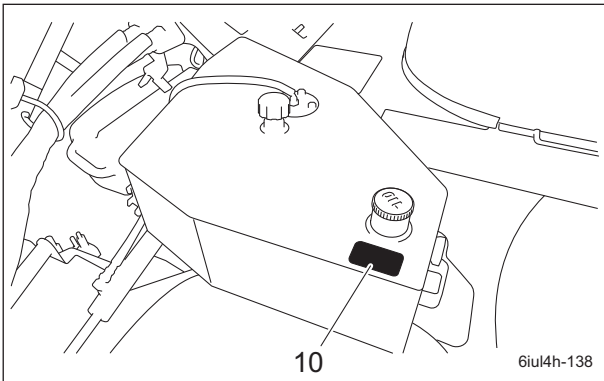

Positions of Safety Decals and Instruction Decals_006

1	Decal for operation 2
2	Caution to rotating object decal
3	Caution to hot parts decal
4	Caution to injury decal
5	Caution for mower lock decal
6	Caution to getting pinched decal
7	Fire prohibited decal
8	Caution for spouting coolant decal
9	PTO caution decal
10	Hydraulic oil icon
11	Diesel fuel icon
12	DO NOT JACK UP decal
13	Instructing operation decal (EN)
14	Caution to noise decal

Description of Safety Decals and Instruction Decals

Decal for Operation 2

Decal for operation 2
LM2400-0918Z0

1.

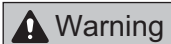

Read the Owner's Operating Manual.

2.



Apply the parking brake, stop the engine, remove the ignition key, and then leave the machine.

3.

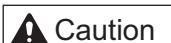

Flying objects - Be sure that people around the machine keep a safe distance away.

4.



May cut your hand or leg - Keep hands and feet away from moving parts.

5.

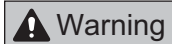

Be careful of exhaust emissions.

6.

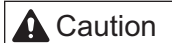

Rollover - Do not work on slopes of 15 degrees or more. When you descend a slope, lower the mower units and then drive at low speed. For ROPS equipped machine, fasten your seatbelt.

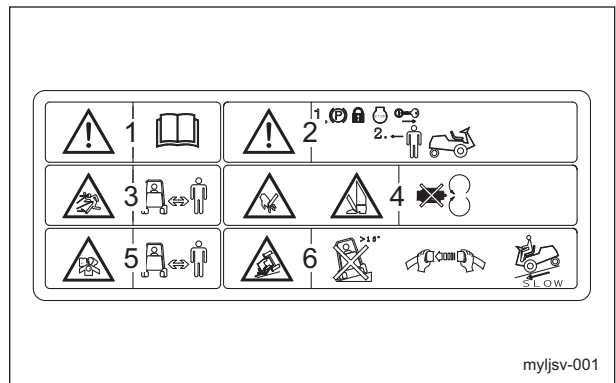

Decal for Operation 2_001

Caution to Rotating Object Decal

K4205001530
Decal, caution to rotating object

Warning

Watch for rotating parts - Keep your hands away from the belts while the engine is running.

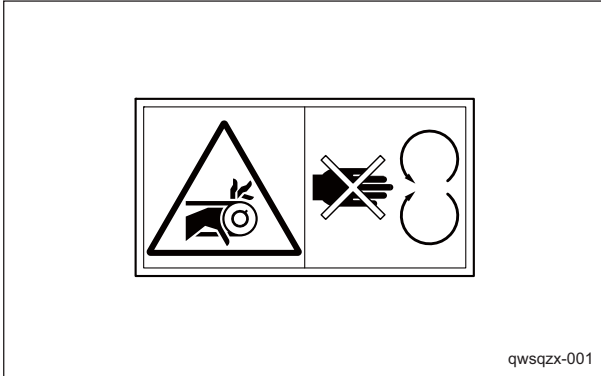

Caution to Rotating Object Decal_001

Caution to Hot Parts Decal

K4205001540
Decal for caution to hot parts

Caution

High temperature - Do not touch. Otherwise, you will get burned.



Caution to Hot Parts Decal_001

Caution to Injury Decal

K4205001580
Decal, caution to injure

Caution

May pinch - There is a risk of being pinched.

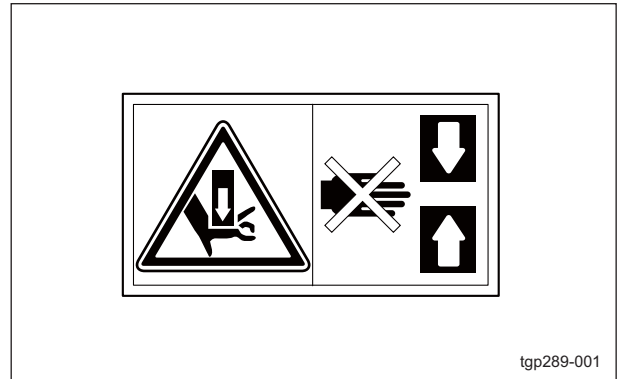

Caution to Injury Decal_001

Caution for Mower Lock Decal

K4205001900
Decal, caution for mower lock
Lock the mower units when traveling or storing with the mower units #4 and 5 raised.



Caution for Mower Lock Decal_001

Product Overview

Caution to Getting Pinched Decal

K4205001930

Decal, caution to getting pinched

Caution
May pinch - There is a risk of being pinched.

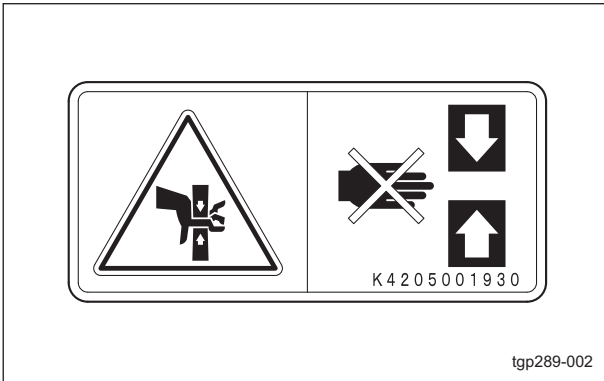

tgp289-002

Caution to Getting Pinched Decal_001

Fire Prohibited Decal

K4205001940

Decal, fire prohibited

Warning
Keep away from fire.



r653fo-001

Fire Prohibited Decal_001

Caution for Spouting Coolant Decal

K4205001970

Decal, caution for spouting coolant

Caution
Caution for spouting coolant - Do not open while hot.
High temperature - Do not touch. Otherwise, you will get burned.

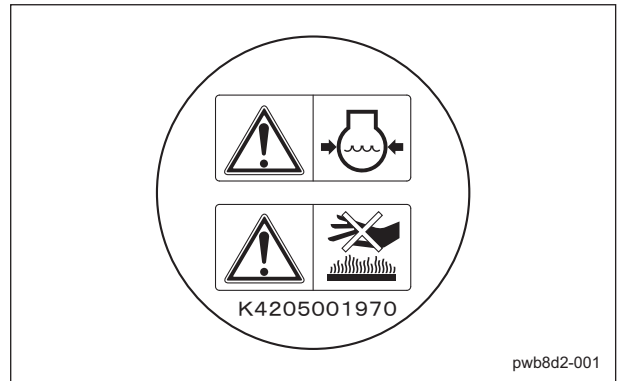

pwb8d2-001

Caution for Spouting Coolant Decal_001

PTO Caution Decal

K4205002000

Decal, caution PTO

Warning
Watch for rotating parts - Keep your hands away from the joints while the engine is running.

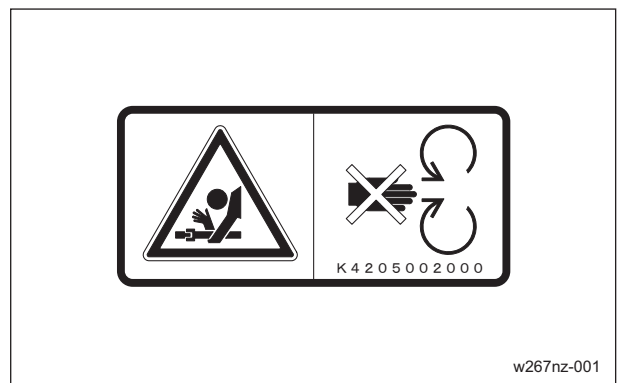

w267nz-001

PTO Caution Decal_001

Product Overview

Hydraulic Oil Icon

K4209000980
Hydraulic oil icon
Read the Owner's Operating Manual.

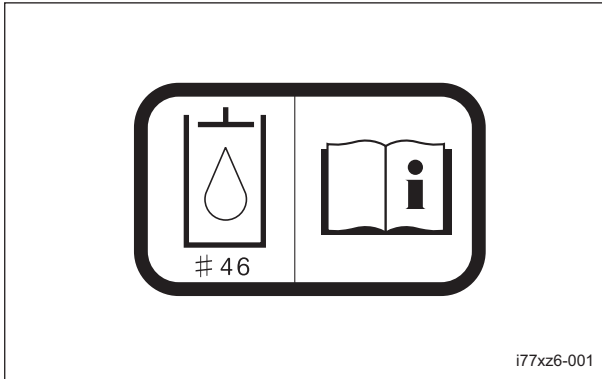

Hydraulic Oil Icon_001

Instructing Operation Decal (EN)

K4205002240
Decal, instructing operation (EN)



Instructing Operation Decal (EN)_001

Diesel Fuel Icon

K4209001000
Diesel fuel icon
Use diesel fuel.

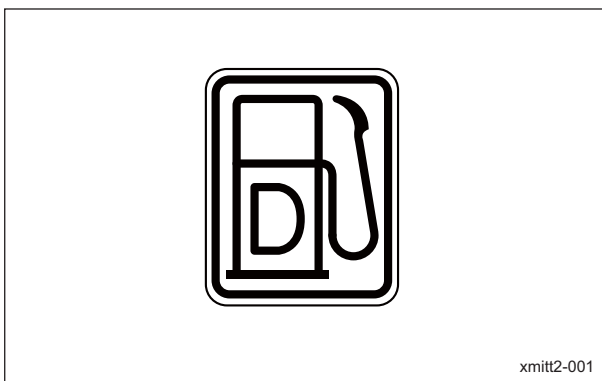

Diesel Fuel Icon_001

Caution to Noise Decal

K4205002090
Decal, caution to noise



Caution to Noise Decal_001

DO NOT JACK UP Decal

K4205002220
Decal, DO NOT JACK UP
Do not jack up.

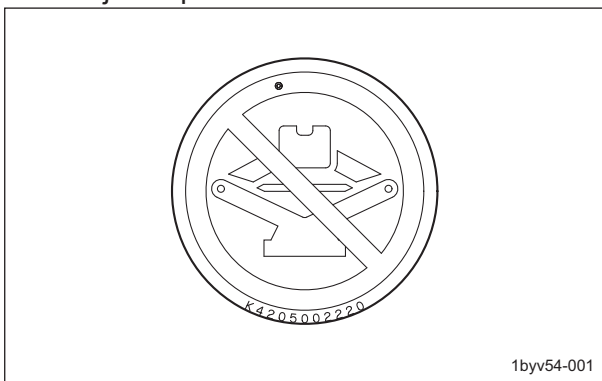

DO NOT JACK UP Decal_001

Product Overview

Handling Instructions

Inspection Before Use	Page 4-2	Description of Operation Decals	Page 4-26
Radiator Cover	Page 4-2	Proximity Sensor	Page 4-30
Radiator	Page 4-2	Relays	Page 4-31
Coolant	Page 4-3	Light Switch	Page 4-31
Oil Cooler	Page 4-5	Traveling/Working Selector Switch	Page 4-32
Hydraulic Oil	Page 4-5	Reel Rotation Switch	Page 4-32
Air Cleaner	Page 4-6	Reel Forward/Reverse Switch	Page 4-33
Battery	Page 4-7	Reel Rotation/Stop Switching Lever	Page 4-33
Tire	Page 4-8	Mower Lock Lever (Latch)	Page 4-33
Brake	Page 4-8	Mower Unit Up/Down Lever	Page 4-34
Belt	Page 4-9	Throttle Knob	Page 4-34
Wire	Page 4-9	DPF Auto Regeneration Inhibit Switch	Page 4-35
Around The Engine	Page 4-9	DPF Parked Regeneration Switch	Page 4-36
Engine Oil	Page 4-9	Traveling Pedal	Page 4-36
Fuel	Page 4-10	Pedal Stopper	Page 4-37
Water Separator	Page 4-12	Brake Pedal	Page 4-37
Fuel Filter	Page 4-14	Open-Close Lever	Page 4-38
Oil Leakage	Page 4-14	Radiator Cover	Page 4-38
Grass Catcher	Page 4-14	Hood	Page 4-38
Tightening Torques	Page 4-15	Underseat Cover	Page 4-39
Standard Tightening Torques	Page 4-15	Step Cover	Page 4-39
Principal Tightening Torques	Page 4-17	Instruments	Page 4-40
Adjustment Before Operating	Page 4-18	Description of Monitor	Page 4-40
Adjustment of Steering Wheel	Page 4-18	Displayed Icon	Page 4-40
Adjustment of Seat	Page 4-18	Main Menu Items	Page 4-41
Adjustment of Reel Rotation Control Valves	Page 4-19	Fault Code Displays	Page 4-57
Adjustment of Mower Stopper Pin	Page 4-20	Travel of Machine	Page 4-68
Adjustment of Mower Stabilizer	Page 4-21	Traveling Procedure	Page 4-68
Adjustment of Stopper Nuts	Page 4-22	Towing The Machine	Page 4-68
Procedure to Start / Stop Engine	Page 4-22	Cutting Work	Page 4-69
Start / Stop of Engine	Page 4-22	Cutting Work	Page 4-69
Safety Mechanisms	Page 4-23	Removal/Installation of Grass Catcher	Page 4-69
Warning Mechanisms	Page 4-24	Transporting	Page 4-70
Operation of Each Section	Page 4-25	Transporting Procedure	Page 4-70
Cautions for when You Leave The Machine	Page 4-25	Long-Term Storage	Page 4-70
Positions of Operation Decals	Page 4-25	Before Long-Term Storage	Page 4-70

Handling Instructions

Inspection Before Use

Be sure to perform an inspection before you start using the machine so that you will be able to take advantage of its optimum performance for a long period of time.

Radiator Cover

Inspection of Radiator Cover

1. Make sure that there is no damage to the radiator cover.
2. Make sure that the radiator cover is not contaminated.

Cleaning of Radiator Cover

Important

An unclean radiator cover may cause overheating or damage to the engine. It may also cause malfunction of the hydraulic system.

If the radiator cover has been contaminated with dust, be sure to clean it. After operating the machine in a dusty environment, it is important to remove dust from the cover as soon as possible.

1. Open the radiator cover.

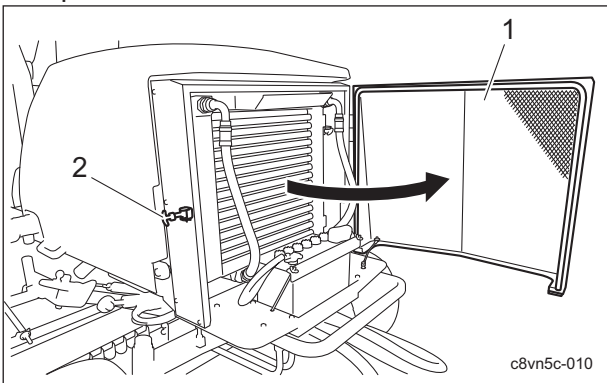

Cleaning of Radiator Cover_001

1	Radiator cover
2	Rubber catch

2. Carefully clean the front and back of the radiator cover with water or compressed air.

Radiator

Inspection of Radiator

1. Make sure that there is no damage to the radiator.

2. Make sure that the radiator is not contaminated.

Cleaning of Radiator

Important

An unclean radiator may cause the engine to overheat or seize. It may also cause malfunction of the hydraulic system.

Important

Do not use solid objects, such as a spatula or screwdriver, or high-pressure water to clean the radiator or oil cooler. Otherwise, special fins or tubes may be damaged, possibly resulting in reduced cooling performance or coolant leakage.

If the radiator has been contaminated with dust, be sure to clean it. Especially after operating the machine in a dusty environment, it is important to remove dust as soon as possible.

1. Open the radiator cover.
2. Remove the cotter pin and washer, and then remove the cable.

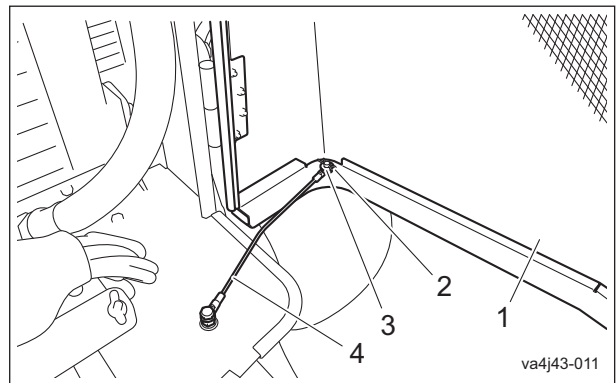

Cleaning of Radiator_001

1	Radiator cover
2	Cotter pin
3	Washer
4	Cable

Handling Instructions

3. Pull up the radiator cover to remove it.

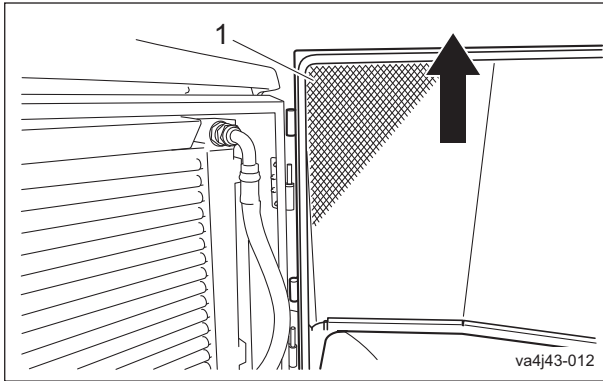

Cleaning of Radiator_002

1	Radiator cover
---	----------------

4. Unlock the rubber catches on the left and right of the oil cooler, and then tilt the oil cooler.

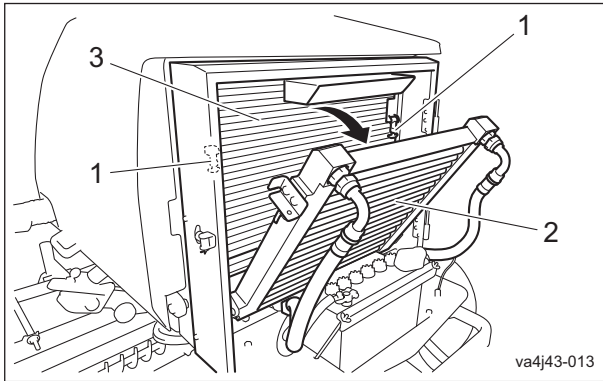

Cleaning of Radiator_003

1	Rubber catch
2	Oil cooler
3	Radiator

5. Carefully clean the radiator with water or compressed air.

6. Open the hood.

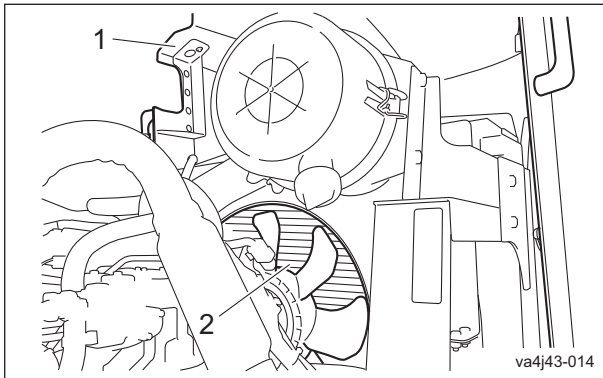

Cleaning of Radiator_004

1	Hood
2	Radiator

7. Carefully clean the radiator with water or compressed air.

Coolant

Inspection of Coolant

⚠ Caution

Do not touch the radiator or coolant during engine operation or immediately after the engine has been turned off. Otherwise, you may get burned.

⚠ Caution

Inspection should take place after the engine has well cooled down.

1. Make sure that the coolant level in the reserve tank is between "FULL" and "LOW".

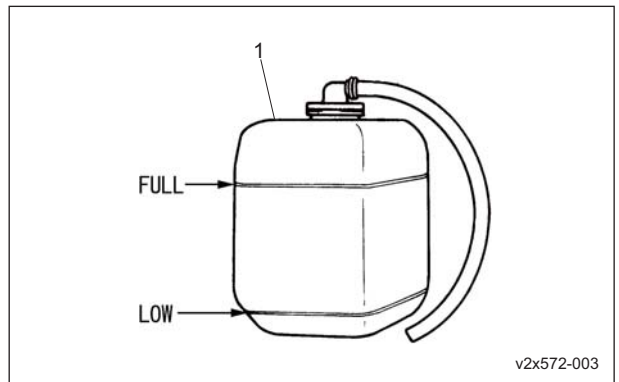

Inspection of Coolant_001

1	Reserve tank
---	--------------

Handling Instructions

Coolant Supply

Caution

Do not touch the radiator or coolant during engine operation or immediately after the engine has been turned off. Otherwise, you may get burned.

Caution

Supply coolant after the engine has well cooled down.

Caution

The radiator cap is pressurized. If you remove the radiator cap while the engine is overheated, hot steam will burst out, possibly resulting in burns. Make sure that the water temperature and pressure are reduced, and then grab the cap with a thick cloth and gradually open the cap.

Important

When supplying coolant, be sure to use clean water.

Important

Tightly close the radiator cap. If the cap is loose or incorrectly installed, water may leak and the engine may overheat.

1. If the coolant level in the reserve tank is lower than the "LOW" mark, open the reserve tank cap, and then supply clean water up to the "FULL" mark.

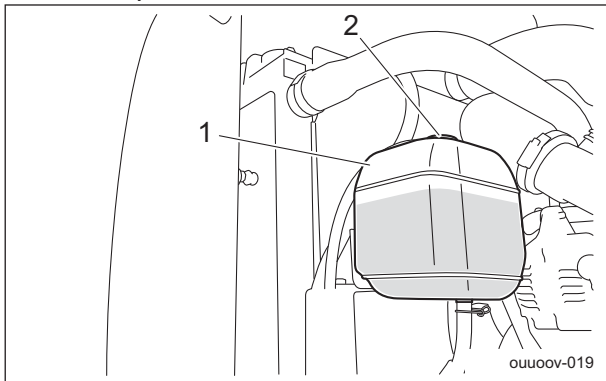

Coolant Supply_001

1	Reserve tank
2	Reserve tank cap

2. If no coolant is in the reserve tank, follow the steps below to supply clean water.

- [1] Open the radiator cap, and then supply clean water up to the opening.
- [2] Open the reserve tank cap, and then supply clean water up to the "FULL" mark.

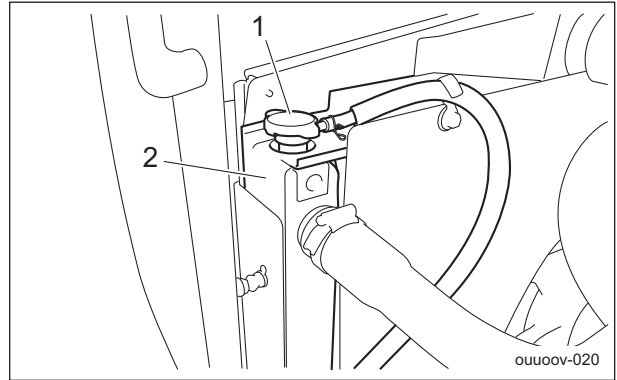

Coolant Supply_002

1	Radiator cap
2	Radiator

Handling Instructions

Oil Cooler

Inspection of Oil Cooler

1. Make sure that there is no damage to the oil cooler.
2. Make sure that the oil cooler is not contaminated.

Cleaning of Oil Cooler

Important

An unclean oil cooler may cause malfunction of the hydraulic system.

Important

Do not use solid objects, such as a spatula or screwdriver, or high-pressure water to clean the radiator or oil cooler. Otherwise, special fins or tubes may be damaged, possibly resulting in reduced cooling performance or coolant leakage.

If the oil cooler has been contaminated with dust, be sure to clean it. Especially after operating the machine in a dusty environment, it is important to remove dust as soon as possible.

1. Open the radiator cover.
2. Unlock the rubber catches on the left and right of the oil cooler, and then tilt the oil cooler.

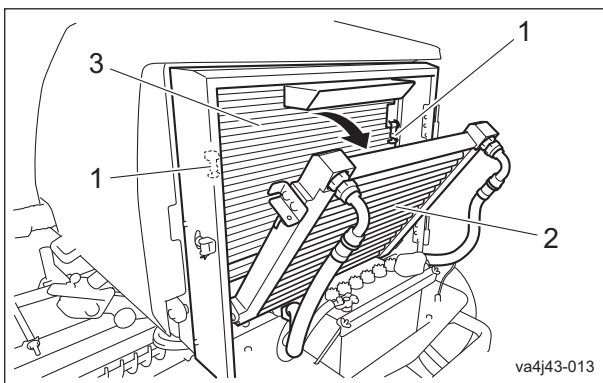

Cleaning of Oil Cooler_001

1	Rubber catch
2	Oil cooler
3	Radiator

3. Carefully clean the front and back of the oil cooler with water or compressed air.

Hydraulic Oil

Inspection of Hydraulic Oil

The oil gauge is on the side of the hydraulic tank.

1. Raise the mower units and maintain that position on a level surface.
2. Make sure that the oil level is at the middle of the oil gauge.

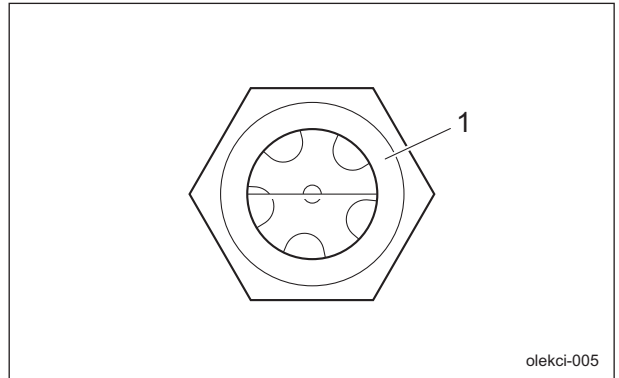

Inspection of Hydraulic Oil_001

1	Oil gauge
---	-----------

3. Check underneath the machine for oil leakage.

Supply of Hydraulic Oil

Important

Do not mix different types of oil.

Important

Use Shell Tellus S2M46 (or equivalent) as hydraulic oil.

1. Remove the screws from the tank cover, and then remove the tank cover.

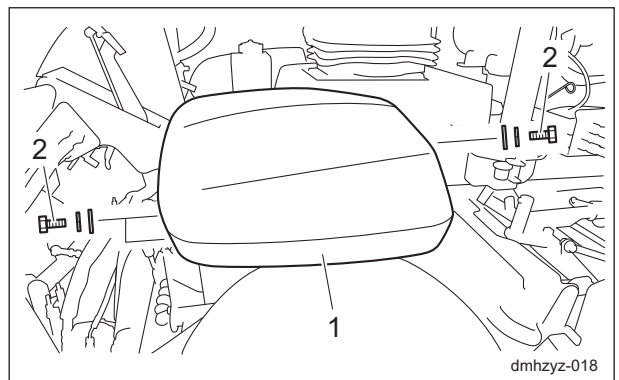

Supply of Hydraulic Oil_001

Handling Instructions

1	Tank cover
2	Screw

2. If the hydraulic oil level is low, follow the steps below to supply oil.

[1] Open the tank cap, and then supply hydraulic oil through the oil filling port until the oil level reaches the middle of the oil gauge on the hydraulic tank.

[2] Tighten the tank cap securely.

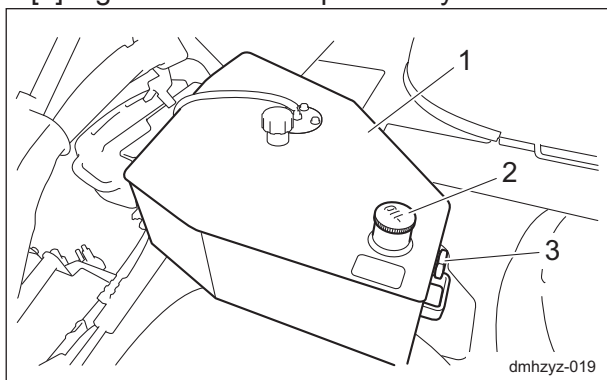

Supply of Hydraulic Oil_002

1	Hydraulic tank
2	Tank cap
3	Oil gauge

3. Start the engine, raise and lower the mower units, and turn the steering wheel right and left.

Move forward and reverse repeatedly several times.

4. Raise the mower units and maintain that position on a level surface, and then check to see if the oil level is at the middle of the oil gauge. If necessary, supply oil.

5. Check underneath the machine for hydraulic oil leakage.

6. Install the tank cover.

Air Cleaner

Inspection of Air Cleaner

The air cleaner is a component that removes dirt from the intake air to prevent wear of the cylinder liners and piston rings so that the engine will always operate smoothly. A contaminated air cleaner element may cause malfunction of the engine.

1. Inspect the air cleaner by checking the vacuum indicator.

If the air cleaner element is contaminated, the vacuum indicator will display a red ring.

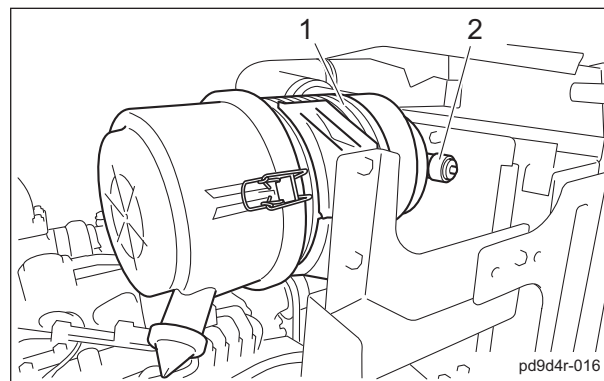

Inspection of Air Cleaner_001

1	Air cleaner
2	Vacuum indicator

2. Make sure that there is no damage to the air cleaner.

3. Make sure that the air cleaner element is not contaminated.

Cleaning of Air Cleaner

A contaminated air cleaner element may cause malfunction of the engine.

To maximize the life of the engine, clean the air cleaner properly.

1. Follow the steps below to clean the air cleaner.

[1] Release the clips, remove the air cleaner cap, and then remove the air cleaner element.

[2] While paying close attention not to damage the air cleaner element, tap a solid portion of the air cleaner element or blow compressed air from its inside to remove dust and dirt.

If the air cleaner element is extremely contaminated, replace it with a new one.

[3] Attach the air cleaner element to the air cleaner body.

[4] Attach the air cleaner cap, and then fix it securely with the clips.

Handling Instructions

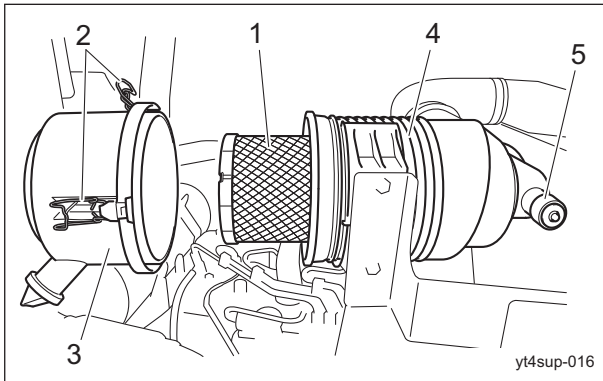

Cleaning of Air Cleaner_001

1	Air cleaner element
2	Clip
3	Air cleaner cap
4	Air cleaner body
5	Vacuum indicator

2. Press the reset button for the vacuum indicator.

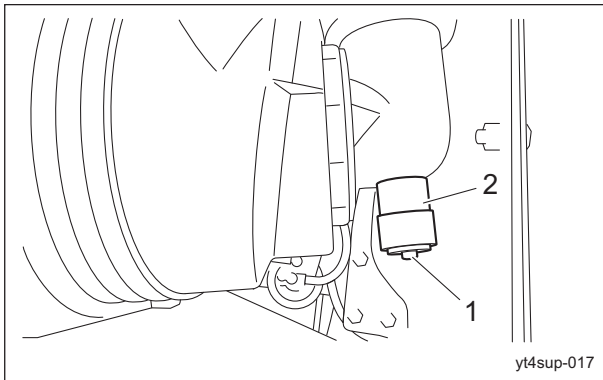

Cleaning of Air Cleaner_002

1	Reset button
2	Vacuum indicator

Battery

Inspection of Battery

⚠ Danger

Keep away from fire while inspecting or charging the battery.
The battery may explode.

⚠ Warning

Do not allow the battery fluid level to become lower than the LOWER LEVEL (minimum fluid level line).
The battery may explode if it is used or charged while the battery fluid level is at the LOWER LEVEL (minimum fluid level line).

⚠ Caution

Implement after the engine and DPF etc. have well cooled down.
Otherwise, you may get burned.

1. Open the radiator cover.

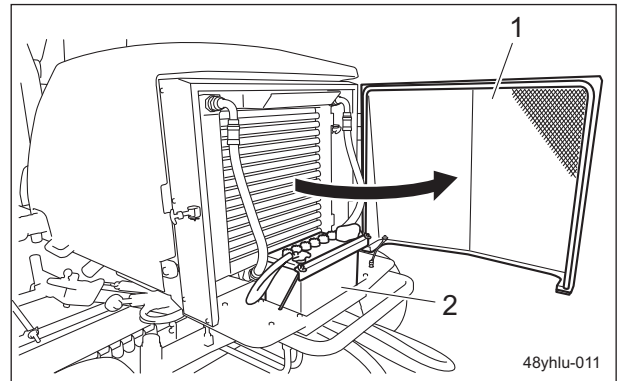

Inspection of Battery_001

1	Radiator cover
2	Battery

2. Clean the areas around the battery fluid level lines using a cloth dampened with water.
3. Make sure that the battery fluid level is between the UPPER LEVEL (maximum fluid level line) and the LOWER LEVEL (minimum fluid level line).

Handling Instructions

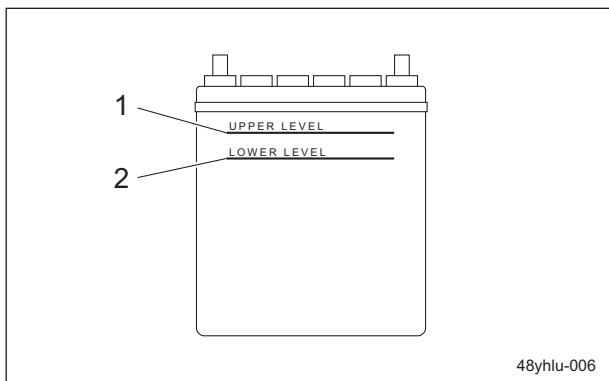

Inspection of Battery_002

1	UPPER LEVEL
2	LOWER LEVEL

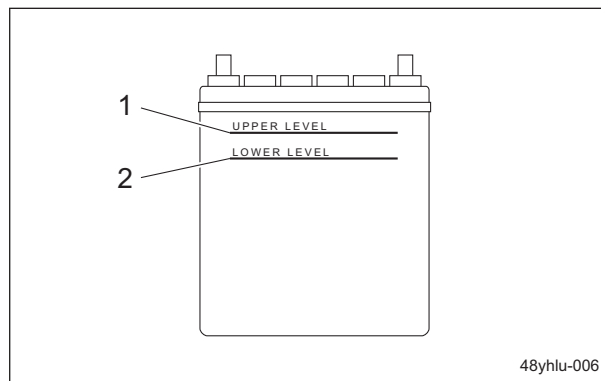

Supply of Battery Fluid_001

1	UPPER LEVEL
2	LOWER LEVEL

Supply of Battery Fluid

⚠ Danger

Be careful not to let your skin, eyes or clothes, etc., come into contact with the battery fluid or accidentally swallow the fluid.

Should your skin or clothes come into contact with the battery fluid, immediately wash them away with water.

⚠ Danger

When you supply battery fluid, wear protective garments and safety glasses, etc.

⚠ Caution

Implement after the engine and DPF etc. have well cooled down.

Otherwise you may get burned.

1. If the battery fluid level is lower than halfway between the UPPER LEVEL (maximum) line and LOWER LEVEL (minimum) line, add purified water up to the UPPER LEVEL (maximum) line.

Tire

Inspection of Tires

1. Check the pneumatic pressure of the tires.
2. Make sure that there are no cracks, damage or abnormal wear.

	Tire size	Pneumatic pressure
Front wheel	26.5 x 14.00-12	120 kPa (1.2 kgf/cm ²)
Rear wheel	20 x 12.00-10	140 kPa (1.4 kgf/cm ²)

Brake

Inspection of Brake

While traveling, depress the brake pedal firmly to make sure that the brake is applied effectively.

Inspection of Parking Brake

1. Depress the locking pedal while firmly depressing the brake pedal to lock it and check that the brake is applied effectively.
2. Firmly depress the brake pedal and release the locking pedal to release the brake pedal, and then check that the brake is not applied.

Handling Instructions

Belt

Inspection of Belt

Warning

The engine must be stopped when the belt is inspected.

Important

A slacking or damaged belt or damaged fan may cause overheating or lack of a battery charge.

1. Press the middle of the belt with your finger to check the belt tension.
2. Make sure that there are no cracks, damage or abnormal wear.

Wire

Inspection of Wire

1. Make sure that the wire is not cracked or damaged.
2. If the wire is cracked or damaged, replace it with a new one immediately.

Around The Engine

Inspection of Engine-Associated Parts

Caution

Implement after the engine and DPF etc. have well cooled down. Otherwise you may get burned.

1. Check the fuel system parts for loosened or cracked joints and leakage. Replace the parts if necessary.
2. Blow compressed air to clean any grass or flammable materials that may be attached on or around the DPF. Remove clippings and dust in a gap thoroughly due to the intricately shaped engine.

Engine Oil

Inspection of Engine Oil

Important

Securely tighten the oil level gauge and oil filler cap.

1. Check the oil level 10 to 20 minutes after stopping the engine.
2. Position the machine so that the engine is level, and then fully insert the oil level gauge to check the oil level.

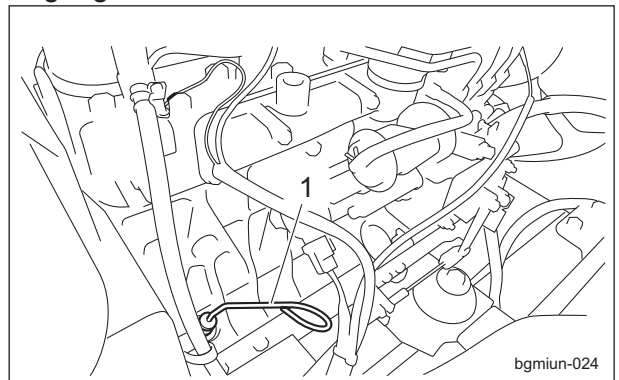

Inspection of Engine Oil_001

1	Oil level gauge
---	-----------------

3. The appropriate oil level should be between the upper and lower limit lines on the gauge.

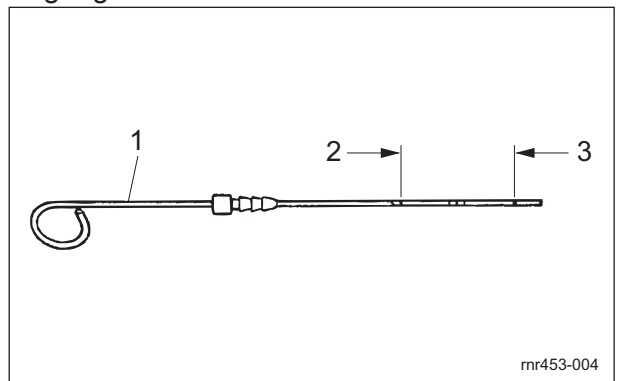

Inspection of Engine Oil_002

1	Oil level gauge
2	Upper limit
3	Lower limit

Handling Instructions

Supply of Engine Oil

Important

Do not supply too much engine oil. Otherwise, the engine may be damaged.

Important

Do not mix different types of engine oil.

Important

Be sure to use engine oil that is classified as JASO standard:DH-2 or API Service Grade: CJ-4, with an SAE Viscosity that is appropriate for the operating environment (ambient temperature).

Important

Securely tighten the oil level gauge and oil filler cap.

1. Engine oil is supplied through the oil filler cap.
Remove the oil filler cap, and then supply new engine oil until the oil reaches a level in between the upper and lower limit lines on the oil level gauge.
2. Securely install the oil filler cap.

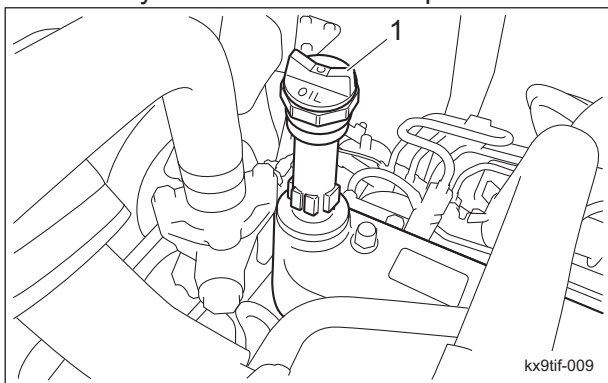

Supply of Engine Oil_001

1	Oil filler cap
---	----------------

3. It will take a while for the supplied engine oil to descend into the oil pan.
Check the oil level again 10 to 20 minutes after replenishment.

Fuel

Inspection of Fuel Quantity

With the machine on a level surface, observe the fuel level in the monitor to check the fuel level.

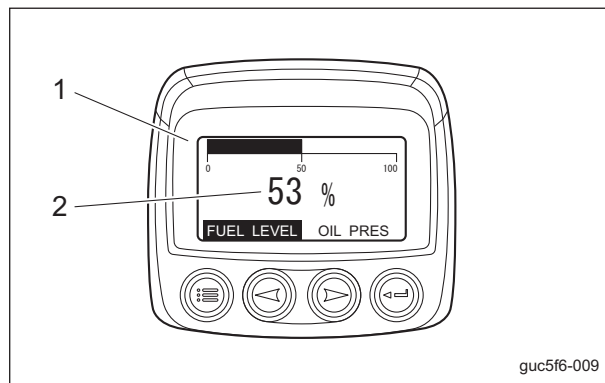

Inspection of Fuel Quantity_001

1	Monitor
2	Fuel level

Handling Instructions

Fuel Supply

Warning

Do not supply additional fuel after the fuel level indicates 100%.
If you supply too much fuel, it might overflow from the fuel cap when you travel or work on a slope.

Warning

Keep fire away while refueling.
Do not smoke.

Important

Use ultra-low sulfur diesel fuel (sulfur-free diesel fuel).

Important

In case of lack of fuel, DPF regeneration can not be performed.

If the monitor displays the warning message "FUEL LEVEL LOW", immediately stop operation, and then supply fuel (diesel). The fuel tank capacity is approximately 51.0 dm³ (51.0 L).

Note:

The factory default low fuel level is 10%. The level can be changed optionally.

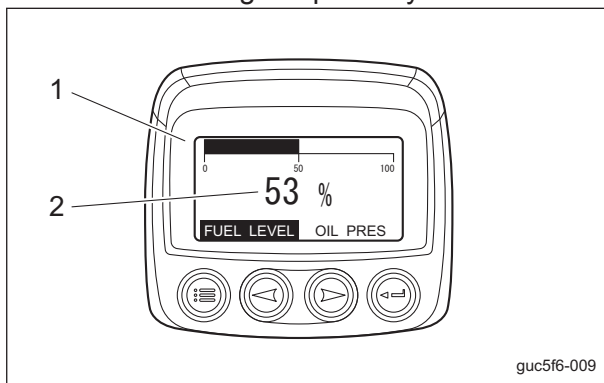

Fuel Supply_001

1	Monitor
2	Fuel level

Air Bleeding of Fuel System

Important

The air-bleed plug should always be in the closed position except during the air bleeding operation.
Using the machine with the air-bleed plug in the open position may cause the engine to stall.

This machine has a function of automatic air bleeding. However, depending on the mechanical structure, it may not bleed air completely. If the automatic air bleeding does not work well, follow the steps below to perform manual air bleeding.

Caution

Do not perform air bleeding when the engine is hot since the fuel may spill on the hot exhaust manifold and a fire might occur.

1. Set the ignition key to the "ON" position.
2. Turn the air-bleed plug on the fuel filter several times to loosen it.
3. When a bubble no longer arises, screw the air-bleed plug to the original position.
4. Open the air-bleed plug on the injection pump.
5. When a bubble no longer arises, screw the air-bleed plug to the original position.
6. Set the ignition key to the "OFF" position.

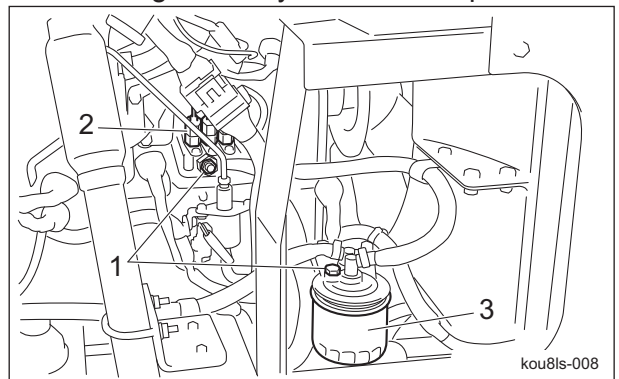

Air Bleeding of Fuel System_001

1	Air-bleed plug
2	Injection pump
3	Fuel filter

Handling Instructions

Water Separator

Inspection of Water Separator

Important

Water-contaminated fuel may impair engine startability, decrease output or damage engine parts.

The water separator removes water from the fuel.

1. Make sure that debris and water have not accumulated in the cup.
With the float raised, water contamination is confirmed.
When the float reaches the drain level, drain the water.

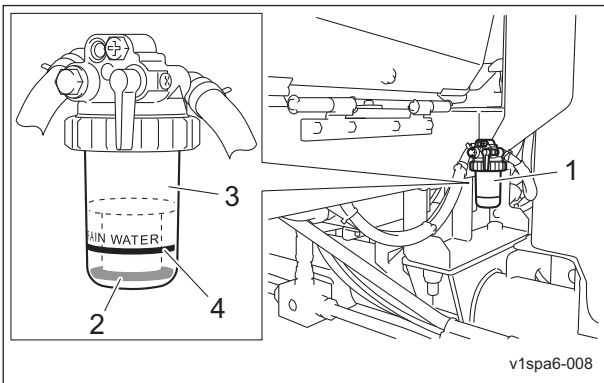

Inspection of Water Separator_001

1	Water Separator
2	Float
3	Cup
4	Drain level

Draining of Water Separator

Important

Water-contaminated fuel may impair engine startability, decrease output or damage engine parts.

Drain the water after at least the number of hours in the Maintenance Schedule and whenever the float is raised by water.

1. Stop the engine, and then turn the key switch to the "OFF" position.
2. Place a container under the water separator.
3. Close the fuel cock of the water separator.

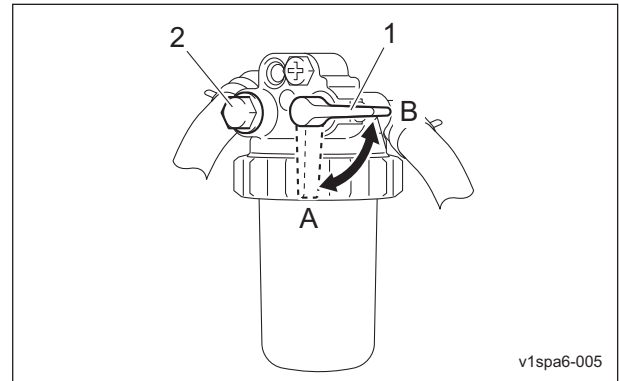

v1spa6-005

Draining of Water Separator_001

1	Fuel cock
2	Air-bleeding plug
A	ON (open)
B	OFF (close)

4. Remove the ring nut, and then remove the cup.

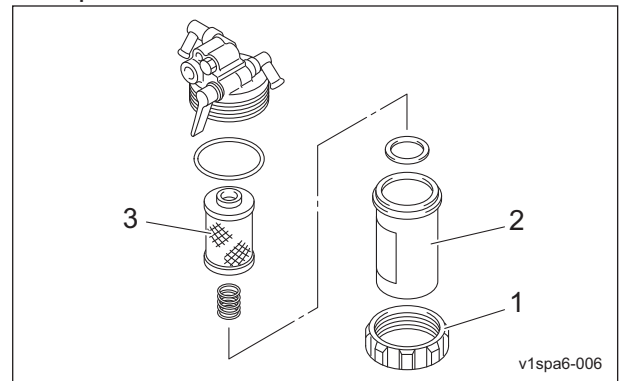

v1spa6-006

Draining of Water Separator_002

1	Ring nut
2	Cup
3	Element

5. Drain the water from the cup.

Important

During installation, prevent contamination with dirt or dust.

If the fuel is contaminated with dirt, dust, etc., the fuel injection pump and injection nozzle will become worn.

6. Correctly install all parts in their original positions.
7. Fill up the fuel tank with fuel.
8. Open the fuel cock of the water separator.

Handling Instructions

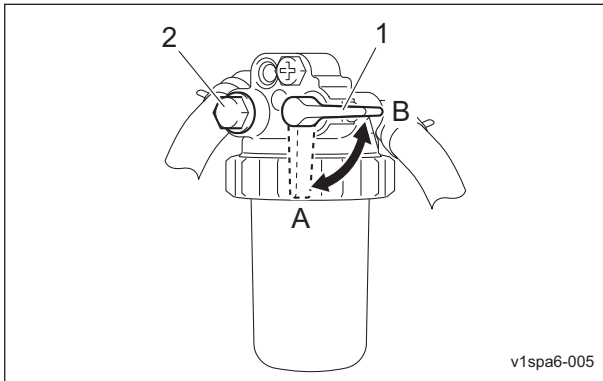

Draining of Water Separator_003

1	Fuel cock
2	Air-bleeding plug
A	ON (open)
B	OFF (close)

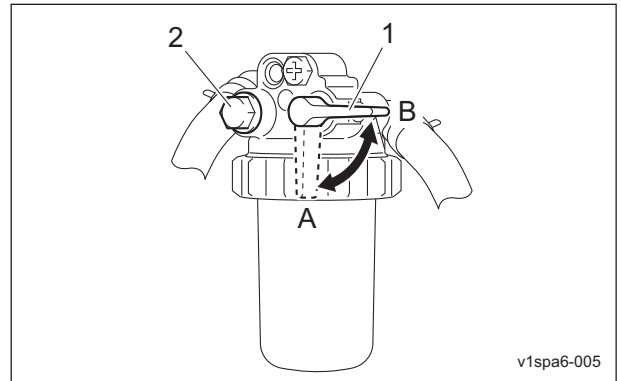

Cleaning of Water Separator_001

1	Fuel cock
2	Air-bleeding plug
A	ON (open)
B	OFF (close)

9. Loosen the air-bleed plug to bleed the air.
10. When the cup is filled with fuel, close the air-bleed plug.
11. If the engine does not start within 15 seconds after switching the ignition key to the "START" position, wait at least 30 seconds, and then repeat the same operation.
If there is still air in the cup after starting the engine, bleed the air again.

Cleaning of Water Separator

Important

Water-contaminated fuel may impair engine startability, decrease output or damage engine parts.

Clean the water separator after at least the number of hours in the Maintenance Schedule and whenever debris has accumulated in the cup.

1. Stop the engine, and then turn the key switch to the "OFF" position.
2. Place a container under the water separator.
3. Close the fuel cock of the water separator.

4. Remove the ring nut, and then remove the cup.

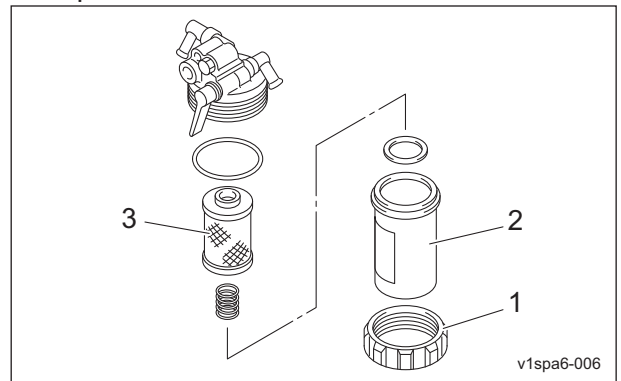

Cleaning of Water Separator_002

1	Ring nut
2	Cup
3	Element

5. Drain the water from the cup.
6. Clean the cup and element with diesel fuel.

Important

During installation, prevent contamination with dirt or dust.

If the fuel is contaminated with dirt, dust, etc., the fuel injection pump and injection nozzle will become worn.

7. Correctly install all parts in their original positions.
8. Fill up the fuel tank with fuel.
9. Open the fuel cock of the water separator.

Handling Instructions

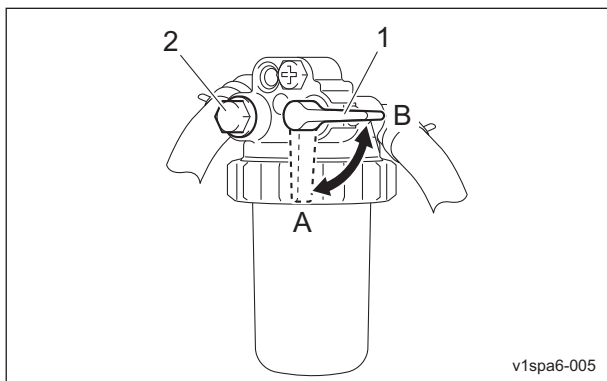

Cleaning of Water Separator_003

1	Fuel cock
2	Air-bleeding plug
A	ON (open)
B	OFF (close)

10. Loosen the air-bleeding plug to bleed the air.
11. When the cup is filled with fuel, close the air-bleeding plug.
12. If the engine does not start within 15 seconds after switching the ignition key to the "START" position, wait at least 30 seconds, and then repeat the same operation.
If there is still air in the cup after starting the engine, bleed the air again.

Fuel Filter

Inspection of Fuel Filter

The fuel filter is positioned between the fuel strainer and the engine, and cleans the fuel flowing into the carburetor.

When the fuel flow becomes insufficient, replace the fuel filter if necessary.

1. Make sure that there is no fuel leakage.
2. Make sure that the fuel filter is not damaged or dirty.

Oil Leakage

Inspection of Oil Leakage

⚠ Caution

When performing maintenance on the hydraulic system, lower the mower units.

After approximately 50 hours of operation, some tightened portions may be loosened and oil and grease may leak.

Be sure to retighten the parts.

Check the bottom of the machine for oil and grease leakage.

Grass Catcher

Inspection of Grass Catcher

The grass catcher may no longer correctly collect grass clippings due to its wear, damage, deformation, etc., caused by frequent use.

1. Make sure that there is no wear or deterioration of the grass catcher.
2. Make sure that there is no damage to the grass catcher.
3. Make sure that there is no interference to moving parts due to deformation of the grass catcher.

Tightening Torques

Important

Refer to the Tightening Torque table.
Note that the Baroness product warranty may not apply to defects caused by incorrect or overtorque tightening, etc.

Standard Tightening Torques

Bolts and Nuts

Important

A number of bolts are used in each part of this machine.
Be sure to re-tighten the bolts and nuts, because they may be loosened at the earlier stage of the use.

As to the bolts and nuts without any special instruction, tighten them in appropriate tightening torque with proper tool.

Too much tightening may cause the looseness or damage of the screw.

The strength of tightening is determined by types of screws, strength, the friction of thread face or base face and others.

The table below is for the galvanized or parkerized bolts.

In case that the strength of internal thread is weak, it is not applied.

Do not use rusty or sand attached "screw."

Otherwise, it may cause insufficient tightening even if you apply the specified tightening torque.

The friction of the screw face becomes higher and the tightening torque is canceled out by the friction, therefore sufficient tightening cannot be applied.

If "screw" is wet by water or oil, do not tighten it with normal tightening torque.

If the screw is wet, the torque coefficient will get smaller and it may result in too much tightening.

Too much tightening may cause looseness by the screw stretched or result in damage.



Do not use a bolt experienced too much burden.

Using the impact wrench requires the skill.

Do exercise as much as possible for steady tightening.

Handling Instructions

Nominal diameter	General bolt		
	Strength classification 4.8		
	 tib3yb-001		
	N-m	kgf-cm	lb-in
M5	3 - 5	30.59 - 50.99	26.55 - 44.26
M6	7 - 9	71.38 - 91.77	61.96 - 79.66
M8	14 - 19	142.76 - 193.74	123.91 - 168.17
M10	29 - 38	295.71 - 387.49	256.68 - 336.34
M12	52 - 67	530.24 - 683.20	460.25 - 593.02
M14	70 - 94	713.79 - 958.52	619.57 - 831.99
M16	88 - 112	897.34 - 1142.06	778.89 - 991.31
M18	116 - 144	1,182.85 - 1,468.37	1,026.72 - 1,274.54
M20	147 - 183	1,498.96 - 1,866.05	1,301.10 - 1,619.73
M22	295	3,008.12	2,611.05
M24	370	3,772.89	3,274.87
M27	550	5,608.35	4,868.05
M30	740	7,545.78	6,549.74

Nominal diameter	Heat-treated bolt					
	Strength classification 8.8			Strength classification 10.9		
	 tib3yb-002			 tib3yb-003		
	N-m	kgf-cm	lb-in	N-m	kgf-cm	lb-in
M5	5 - 7	50.99 - 71.38	44.26 - 61.96	7 - 10	71.38 - 101.97	61.96 - 88.51
M6	8 - 11	81.58 - 112.17	70.81 - 97.36	14 - 18	142.76 - 183.55	123.91 - 159.32
M8	23 - 29	234.53 - 295.71	203.57 - 256.68	28 - 38	285.52 - 387.49	247.83 - 336.34
M10	45 - 57	458.87 - 581.23	398.30 - 504.51	58 - 76	591.43 - 774.97	513.36 - 672.68
M12	67 - 85	683.20 - 866.75	593.02 - 752.34	104 - 134	1,060.49 - 1,366.40	920.50 - 1186.03
M14	106 - 134	1,080.88 - 1,366.40	938.21 - 1,186.03	140 - 188	1,427.58 - 1,917.04	1,239.14 - 1,663.99
M16	152 - 188	1,549.94 - 1,917.04	1,345.35 - 1,663.99	210 - 260	2,141.37 - 2,651.22	1,858.71 - 2,301.26
M18	200 - 240	2,039.40 - 2,447.28	1,770.20 - 2,124.24	280 - 340	2,855.16 - 3,466.98	2,478.28 - 3,009.34
M20	245 - 295	2,498.27 - 3,008.12	2,168.50 - 2,611.05	370 - 450	3,772.89 - 4,588.65	3,274.87 - 3,982.95
M22	-	-	-	530	5,404.41	4,691.03
M24	-	-	-	670	6,831.99	5,930.17
M27	-	-	-	1,000	10,197.00	8,851.00
M30	-	-	-	1,340	14,628.78	11,860.34

Note:

The same values are applied to "fine screw thread."

Handling Instructions

Principal Tightening Torques

Tightening Torque by Model

LM551

LM551A

Tighten the following bolts and nuts at the torque specified in the table.

For thread locking adhesive, apply a middle strength thread locker (ThreeBond 1322 or equivalent anaerobic sealant).

Location		Code	Part name	Tightening torque			Thread locking adhesive
				N-m	kgf-cm	lb-in	
Front wheel	Motor	K0013120702	BOLT, HT M12-70	104 - 134	1,060.49 - 1,366.40	920.50 - 1186.03	—
	Wheel mounting base	-	Slotted nut 1-20UNEF of hydraulic motor	280 - 300	2,855.16 - 3,059.10	2,478.28 - 2,655.30	—
	Wheel	K0034120352	BOLT, 8T P1.5 M12-35	67 - 85	683.20 - 866.75	593.02 - 752.34	—
Rear wheel	Motor	K0010120602	BOLT, HT M12-60	104 - 134	1,060.49 - 1,366.40	920.50 - 1186.03	—
	Wheel mounting base	-	Slotted nut 1-20UNEF of hydraulic motor	280 - 300	2,855.16 - 3,059.10	2,478.28 - 2,655.30	—
	Wheel	K0034120352	BOLT, 8T P1.5 M12-35	67 - 85	683.20 - 866.75	593.02 - 752.34	—
Engine		K0017100252	BOLT, SMALL HT P1.25 M10-25	45 - 76	458.87 - 774.97	398.30 - 774.97	○
		K0010121201	BOLT, HT M12-120	67 - 134	683.20 - 1,366.40	593.02 - 1,186.03	—
		K3680000030	M3.5 Screw (accessories)	0.78 - 1.18	7.95 - 12.03	6.90 - 10.44	—
Joint		K0024100401	BOLT, W/HEX. HOLE M10-40	62 - 72	632.21 - 734.18	632.21 - 734.18	○
		K0011100252	BOLT, HT P1.25 M10-25	45 - 76	458.87 - 774.97	398.30 - 774.97	—
Tie rod		- (K1610000020)	Slotted nut(END ASSY, TIE-ROD MALE (RH))	45	458.87	398.30	—
		- (K1611000020)	Slotted nut(END ASSY, TIE-ROD MALE (LH))	45	458.87	398.30	—
Piston pump		K0013140452	BOLT, HT M14-45	140 - 188	1,427.58 - 1,917.04	1,239.14 - 1,663.99	—
Cross valve		K0013101202	BOLT, HT M10-120	29 - 38	295.71 - 387.49	256.68 - 336.34	—
Seat		- (K1700000430)	M8 Bolt and Nut (accessories)	-	-	-	○
Mower stopper		K0041060122	SCREW, + FLAT HEAD M6-12	-	-	-	○

Handling Instructions

Adjustment Before Operating

Adjustment of Steering Wheel

Warning

Do not make adjustments while traveling since doing so is dangerous.

Caution

Be sure the steering wheel position is securely locked. If it becomes loose while traveling, an unexpected accident may occur.

The steering wheel can be adjusted up or down.

Adjust the position to fit the operator.

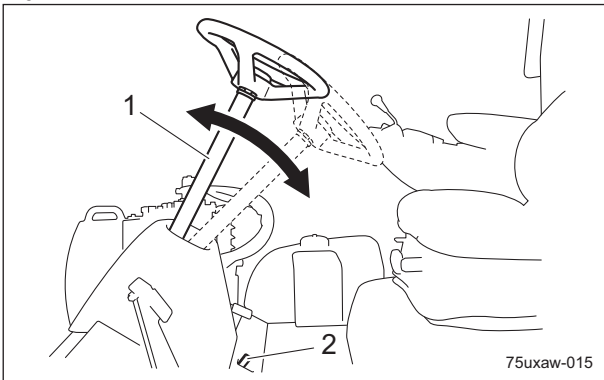

Adjustment of Steering Wheel_001

1	Steering
2	Tilt lever

Shift the tilt lever to the "FREE" position, move the steering wheel to the position that suits the work requirements, and then shift the tilt lever to the "LOCK" position to secure the steering wheel in place.

The tilt lever is located in the driver's left foot area.

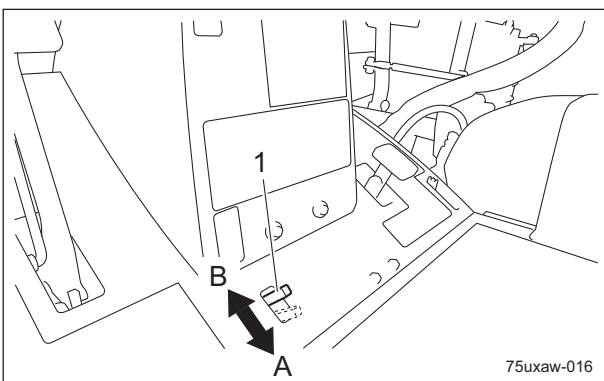

Adjustment of Steering Wheel_002

1	Tilt lever
A	FREE (released)
B	LOCK (locked)

Adjustment of Seat

Use the adjustment levers to adjust the seat. Adjust the position to fit the operator.

1. Use the forward/backward adjustment lever to adjust the seat back and forth.
2. Use the tilt adjustment lever to adjust the angle of the backrest.
3. Turn the suspension adjustment handle to adjust the firmness of the seat suspension. Refer to the suspension indicator while making adjustments. [45 to 130 kg (99.2 to 286.6 lb)]
4. Turn the armrest adjustment knob to adjust the angle of the armrests.
5. Turn the seat height adjustment knob to adjust the height of the seat steplessly. [0 to 60 mm (0 to 2.36 in)]

Adjust the height of the seat while sitting in it.

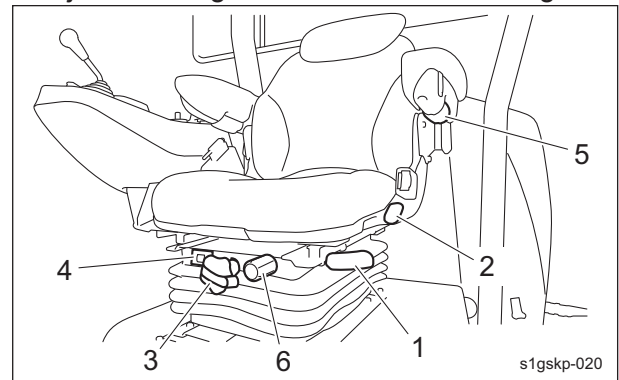

Adjustment of Seat_001

1	Forward/backward adjustment lever
2	Tilt adjustment lever
3	Suspension adjustment handle
4	Suspension indicator
5	Armrest adjustment knob
6	Seat height adjustment knob

Handling Instructions

Adjustment of Reel Rotation Control Valves

The reel rotation control valves adjust the rotation speeds of the reel cutters (cutting cylinders).

Adjust according to the operating conditions. A label listing dial settings for corresponding reel rotation speeds is attached.

Adjust the reel rotation control valve to the setting for the reel rotation speed listed on the reel rotation label.

"TURNS" means the rotation number of the dial's counterclockwise rotation started from the state where the dial is fully tightened clockwise.

"POS" means the dial decal number pointed by the indicating screw.

Note:

The factory default reel rotation speed is set to 1,450 rpm.

LH6* / LS6*			LH52		
TURNS	POS	REEL SPEED	TURNS	POS	REEL SPEED
2	6	1,150	1	7	1,250
	8	1,250		8	1,350
3	2	1,350	2	1	1,450
	4	1,450		2	1,550
	6	1,500		3	1,700

FOR 0 (STARTING POS) TURN CW TO MAX POS

96fzvf-005

Adjustment of Reel Rotation Control Valves_001

1. Stop the engine.
2. Open the underseat cover.
3. Use the specialized wrench (accessory) to loosen the lock nut for the dial.

Note:

Raise the lock nut to a position where it will not interfere when the dial is turned.

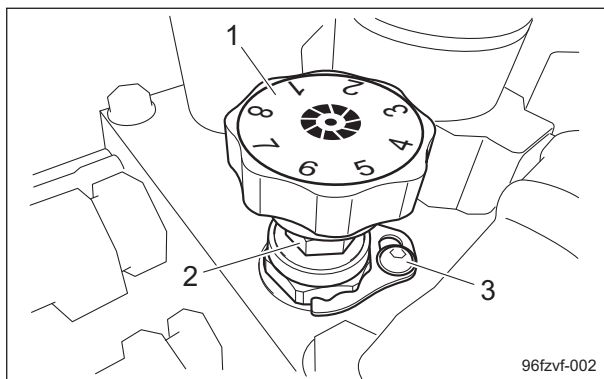

Adjustment of Reel Rotation Control Valves_002

1	Dial
2	Lock nut
3	Indicating screw

Important

In order to maintain quality mowing, the reel rotation speed must be the same for all mower units.

4. Turn the dial to set it to the appropriate position.
Set the two dials to the same position.

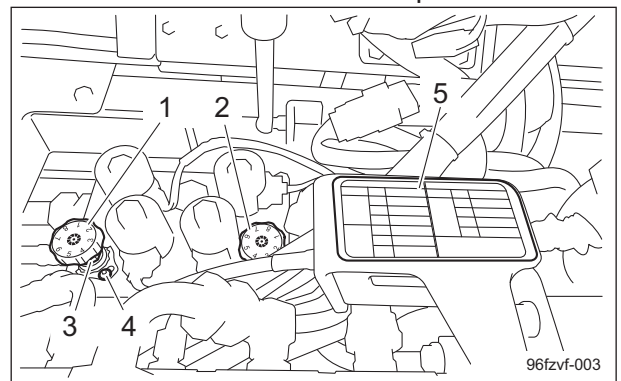

Adjustment of Reel Rotation Control Valves_003

1	Dial (mower units #1, #4 and #5)
2	Dial (mower units #2 and #3)
3	Lock nut
4	Indicating screw
5	Reel rotation label

5. Tighten the lock nut for the dial.
If the dial rotation number is unknown, follow the steps below to adjust the dial.

1. Stop the engine.
2. Open the underseat cover.
3. Use the specialized wrench (accessory) to loosen the lock nut for the dial.

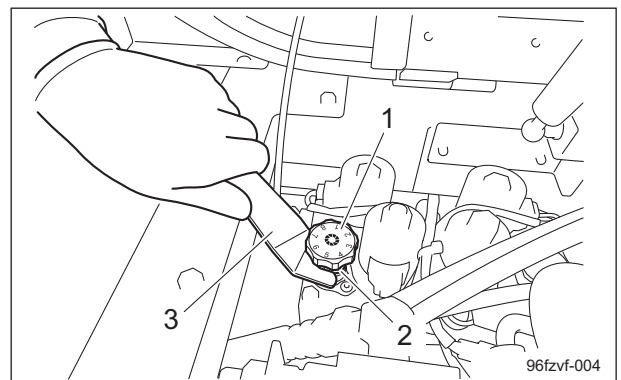

Adjustment of Reel Rotation Control Valves_004

Handling Instructions

1	Dial (mower units #1, #4 and #5)
2	Lock nut
3	Specialized wrench (accessory)

Note:

Raise the lock nut to a position where it will not interfere when the dial is turned.

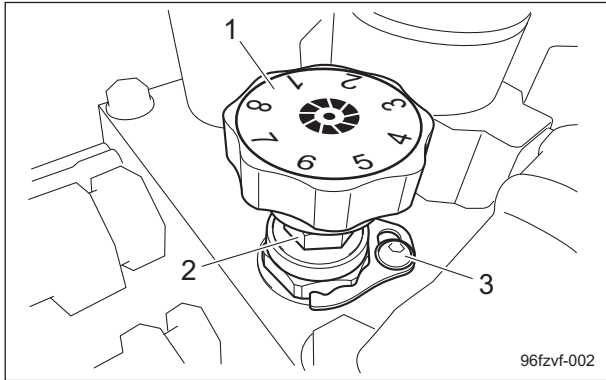

Adjustment of Reel Rotation Control Valves_005

1	Dial
2	Lock nut
3	Indicating screw

4. Turn the dial clockwise until it stops.
5. Turn the dial counterclockwise to set it to the appropriate position.

The amount that the dial is turned differs depending on the mower unit. For example, the following procedures show the steps to set the reel rotation speed to 1,450 rpm.

When mower unit LS62 or LS66/LH62 is installed:

Turn the dial counterclockwise three times, then an additional 180 degrees. Position "4" on the dial sticker should be aligned with the center of the indicating screw.

When mower unit LH52 is installed:

Turn the dial counterclockwise two times, then an additional 45 degrees.

Position "1" on the dial sticker should be aligned with the center of the indicating screw.

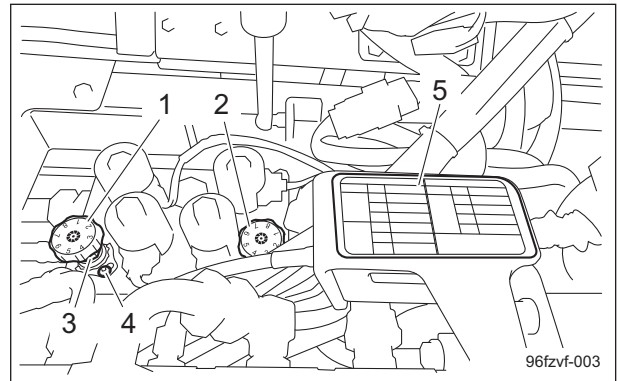

Adjustment of Reel Rotation Control Valves_006

1	Dial for mower units #1, #4 and #5
2	Dial for mower units #2 and #3
3	Lock nut
4	Indicating screw
5	Reel rotation label

6. Use the specialized wrench (accessory) to tighten the lock nut for the dial.

Adjustment of Mower Stopper Pin

The mower stopper pin can prevent or allow tilting of the mower units. Adjust according to the operating conditions.

Fixed:

- The mowing line while traveling straight ahead is a straight line. (The mowing line is easy to see.)
- The mower units do not tilt while operating on slopes, and incomplete mowing can be reduced.

Released:

- It is appropriate when turning while mowing or it is easy to follow undulations.
1. On a level surface, lower all mower units.
 2. Apply the parking brake, and then stop the engine.
 3. Adjust the position of the mower stopper pin, and then insert the cotter pin.

Handling Instructions

To fix:
Insert the cotter pin into the upper hole in the mower stopper pin.

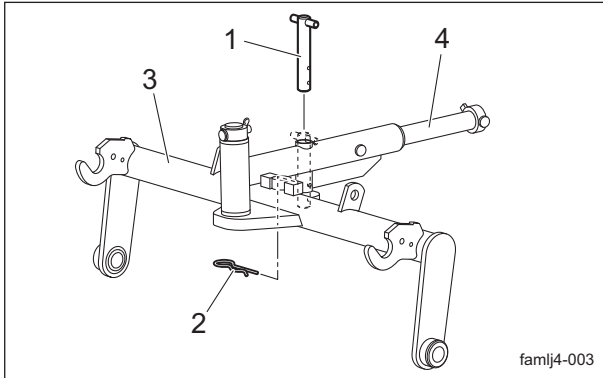

Adjustment of Mower Stopper Pin_001

1	Mower stopper pin
2	Cotter pin
3	Mower arm
4	Mower coupling

To release:
Insert the cotter pin into the lower hole in the mower stopper pin.

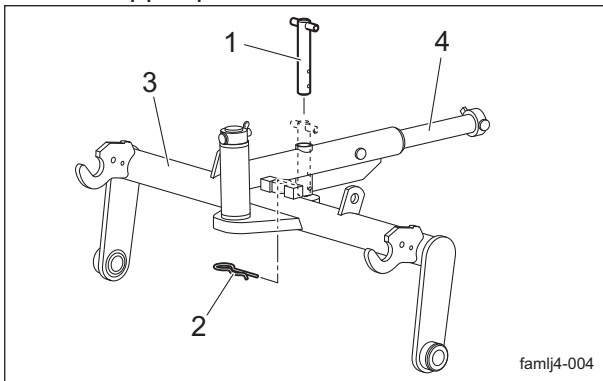

Adjustment of Mower Stopper Pin_002

1	Mower stopper pin
2	Cotter pin
3	Mower arm
4	Mower coupling

The mower stabilizer stabilizes the mower units and prevents an undulating finish (a phenomenon called Marcelling).

1. On a level surface, lower all mower units.
2. Apply the parking brake, and then stop the engine.
3. Loosen the lock nut.
4. Tighten the nut to adjust the length of the spring (compression).
 - Mower #1 to #5: 140.0 mm (5.51 in)
5. Tighten the lock nut.

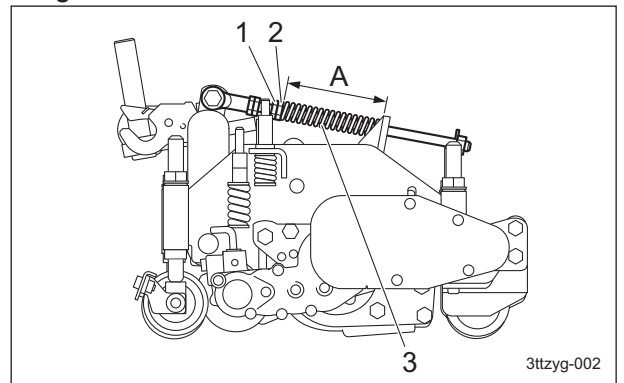

Adjustment of Mower Stabilizer_001

1	Lock nut
2	Nut
3	Spring
A	140.0 mm (5.51 in)

Adjustment of Mower Stabilizer

Note:
Depending on the specifications, this function may not be available.

Important

After adjusting the cutting height, adjust the mower stabilizer.

Handling Instructions

Adjustment of Stopper Nuts

Note:

Depending on the specifications, this function may not be available.

The stopper nut adjusts the movement range of the mower unit.

1. Apply the parking brake, and then stop the engine.

Important

When a grass catcher is installed on LH52 (5-inch mower unit), a large movement range of the mower may cause the grass catcher to come into contact with the front roller when the mower unit is raised.

Exercise care in the position of the stopper nut.

2. Turn the nut to adjust the length of A.

- Mower #1, #4 and #5: 15.0 mm (0.59 in)
- Mower #2 and #3: 40.0 mm (1.57 in)

When a grass catcher is installed on LH52 (5-inch mower unit):

- Mower #1, #4 and #5: 30.0 mm (1.18 in)
- Mower #2 and #3: 40.0 mm (1.57 in)

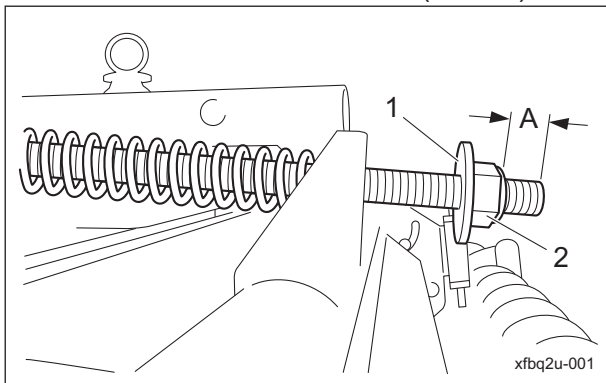

Adjustment of Stopper Nuts_001

1	Washer
2	Nut
A	Length

Procedure to Start / Stop Engine

Start / Stop of Engine

Procedure to Start Engine

Caution

Before starting the engine, make sure that there are no other people or obstacles around the machine.

Caution

Be careful of the mower units lowering when the mower unit up/down lever is shifted to the "Down" position and the key switch is turned to the "ON" position while the engine is stopped with the traveling/working selector switch set to the "Working" position.

Important

Starter operation must take 15 seconds or less.

If the engine still does not start, stop using the battery for 30 to 60 seconds to avoid exhausting the battery.

1. Open the fuel cock of the water separator.

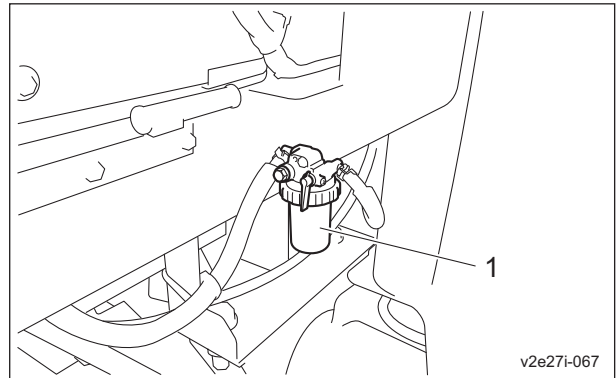

Procedure to Start Engine_001

1	Water Separator
---	-----------------

2. Sit on the seat.
3. Make sure that you have depressed the brake pedal and applied the parking brake.
4. Set the reel rotation switch to the "Stop" position.
5. Move the mower unit up/down lever to the neutral position.
6. Make sure that the traveling pedal is in neutral position.

Handling Instructions

7. Move the throttle knob from the "Low speed" position halfway toward the "High speed" position.
8. Switch the ignition key to the "ON (GLOW)" position.

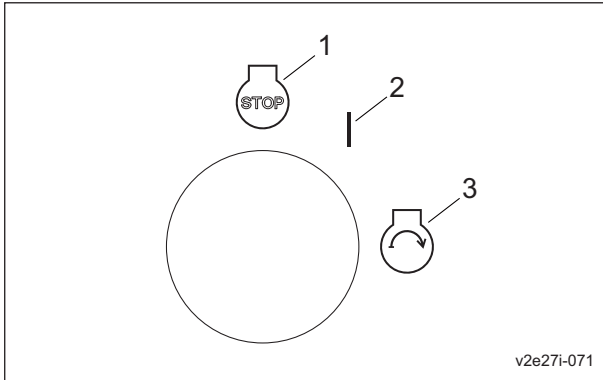

Procedure to Start Engine_002

1	OFF
2	ON (GLOW)
3	START

Caution

When the ignition key is switched to the "ON" position, "Warming up" may appear in the monitor display. Do not start the engine until the message disappears.

9. Make sure that the glow plug is generating heat, the "BARONESS" logo or "Warming up" message appears in the monitor display, and the yellow and red LEDs are lit.

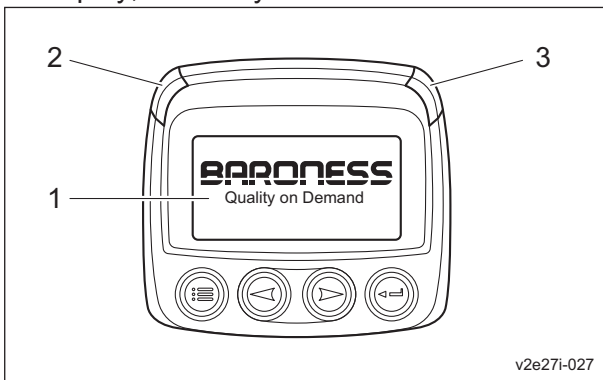

Procedure to Start Engine_003

1	Monitor display
2	Yellow LED
3	Red LED

Caution

Quickly returning the ignition key from the "START" position to the "ON" position may result in damage to the machine.

10. After the "BARONESS" logo and the yellow and red LEDs go off and the parameters (items and values such as the rotation speed) appear, immediately set the ignition key to the "START" position.
11. When the starter starts rotating and the engine starts, slowly return the ignition key to the "ON" position.
12. Move the throttle knob to the "Low speed" position, and then warm up the engine for 1-2 minutes.
13. Gradually move the throttle knob toward the "High speed" position.

Procedure to Stop Engine

1. Set the traveling pedal to the neutral position.
2. Depress the brake pedal, and then apply the parking brake.
3. Set the reel rotation switch to the "Stop" position.
4. Shift the throttle knob to the "Low speed" position, and then idle the machine for 1 to 2 minutes.
5. Switch the ignition key to the "OFF" position.
6. Make sure that the engine has stopped.
7. Remove the ignition key.
8. Leave the driver's seat.
9. Close the fuel cock of the water separator.

Safety Mechanisms

This machine features a safety device for starting/stopping the engine.

1. As for starting the engine, the safety device prevents the engine from starting unless it meets each of the following four conditions.
 - An operator is sitting on the seat.
 - The parking brake is applied.
 - The reel rotation switch is set to the "OFF" position.
 - The traveling pedal is set to the neutral position.

Handling Instructions

Important

When you restart the engine after the safety device stops the engine, be sure to return the ignition key to the "OFF" position first, and then restart it.
Otherwise the engine does not start.

2. In the event the operator leaves the seat with the parking brake applied and the engine running, the safety device will be activated and will stop the engine under any of the following conditions:
 - The traveling pedal is not set to the neutral position. (The operator has depressed the traveling pedal.)
 - The reel rotation switch is set to the "Rotate" position.
However, when the reel reverse switch is set to the "ON" position (reverse rotation), the engine does not stop.

Warning Mechanisms

This machine features various warning mechanisms.

1. Overheat Warning Buzzer
If the water temperature inside the engine exceeds 110 degrees Celsius, a buzzer will sound. (intermittent tone)
2. Hydraulic Oil Level Warning Buzzer
If the oil level in the hydraulic tank decreases by approximately 3.0 dm³ (3.0 L) from the specified level, a buzzer will sound. (continuous tone)
3. Engine Overload Warning Buzzer
If the traveling pedal is depressed and the speed exceeds 12.0 km/h while the pedal stopper is in the "OFF" position and the reel cutters (cutting cylinders) are rotating, a buzzer will sound. (intermittent tone)
4. Warning Buzzer for Traveling With Brake Applied
If the traveling pedal is depressed while the parking brake is applied, a buzzer will sound. (continuous tone)

Warning Buzzer

There are two warning buzzers, which indicate four warnings.

- Warning buzzer 1 & 2
 - Warning buzzer 3 & 4
1. Overheat Warning Buzzer
If the water temperature inside the engine exceeds 110 degrees Celsius, a buzzer will sound. (intermittent tone)
When the buzzer sounds, stop the engine immediately, and then inspect the machine and perform any necessary maintenance.
 2. Hydraulic Oil Level Warning Buzzer
If the oil level in the hydraulic tank decreases by approximately 3.0 dm³ (3.0 L) from the specified level, a buzzer will sound. (continuous tone)
When the buzzer sounds, remove the load from the engine, idle the machine for five minutes, stop the engine, and then inspect the machine and perform any necessary maintenance.
 3. Engine Overload Warning Buzzer
If the traveling pedal is depressed and the speed exceeds 12.0 km/h while the pedal stopper is in the "OFF" position and the reel cutters (cutting cylinders) are rotating, a buzzer will sound. (intermittent tone)
When the buzzer sounds, adjust the speed to 12.0 km/h or less.
 4. Warning Buzzer for Traveling With Brake Applied
If the traveling pedal is depressed while the brake pedal is locked with the locking pedal, a buzzer will sound. (continuous tone)
When the buzzer sounds, firmly depress the brake pedal to release the locking pedal.

Handling Instructions

Operation of Each Section

Cautions for when You Leave The Machine



Caution
If the brakes are not sufficiently effective, use the wheel stoppers to secure the machine.

Positions of Operation Decals

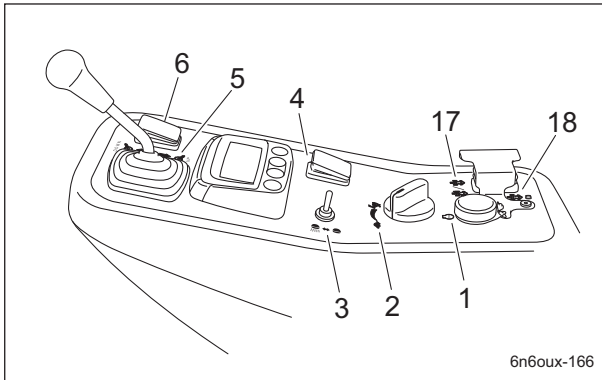

Positions of Operation Decals_001

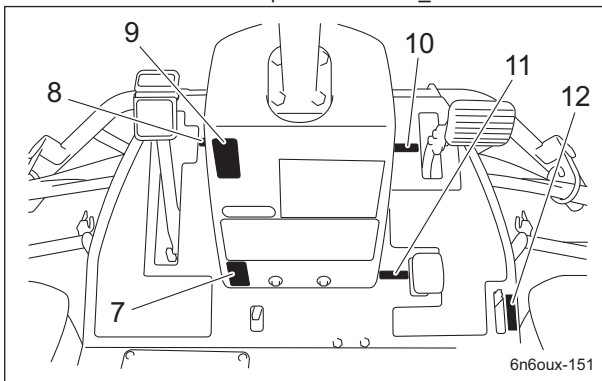

Positions of Operation Decals_002

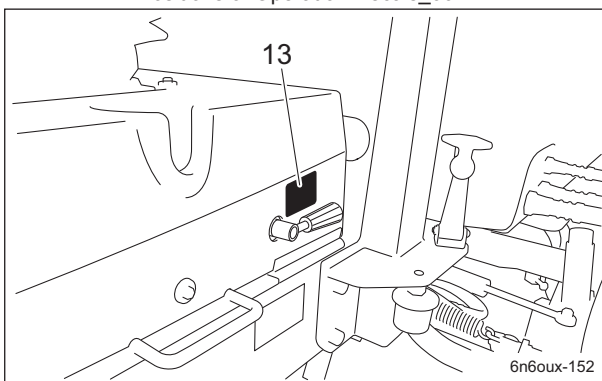

Positions of Operation Decals_003

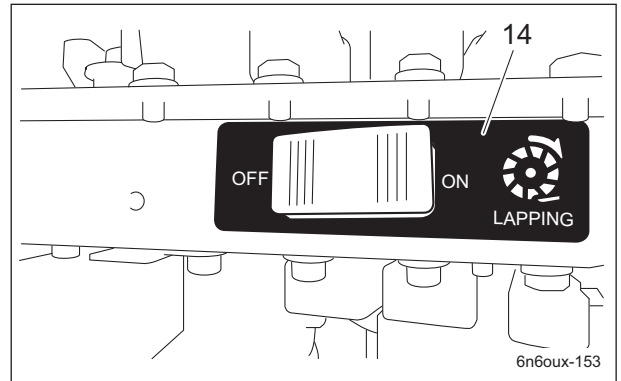

Positions of Operation Decals_004

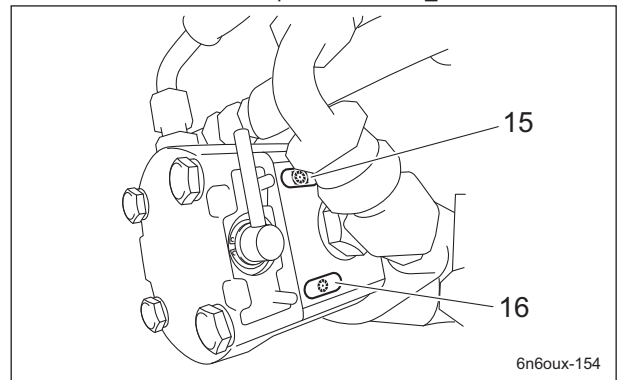

Positions of Operation Decals_005

1	Key switch decal
2	Engine rotation mark
3	Light switch mark
4	Reel rotation switch mark
5	Mower unit up/down lever decal
6	Traveling/working selector mark
7	Tilt steering decal
8	Parking brake decal
9	BRAKE decal
10	FORWARD decal
11	BACKWARD decal
12	Engine rotation decal
13	Lever open/close decal
14	Lapping decal
15	Reel rotation decal
16	Reel stop decal
17	DPF auto regeneration inhibit switch decal
18	DPF parked regeneration switch decal

Handling Instructions

Description of Operation Decals

Key Switch Decal

Decal, key switch

This indicates the key switch positions.

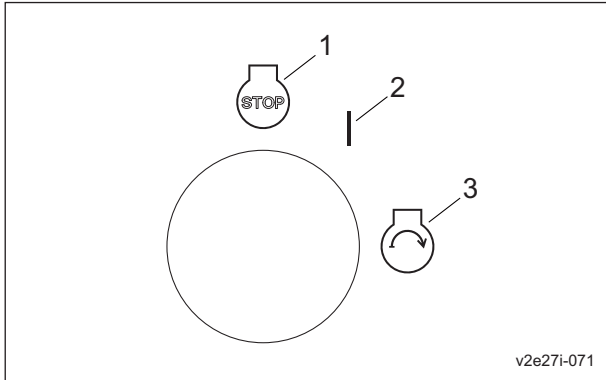

Key Switch Decal_001

1	OFF
2	ON (GLOW)
3	START

Light Switch Mark

Note:

Depending on the specifications, this function may not be available.

Light switch mark

It illustrates ON/OFF of the light.

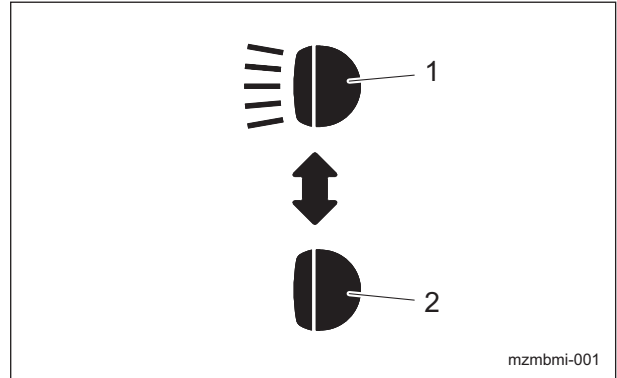

Light Switch Mark_001

1	ON
2	OFF

Engine Rotation Mark

Engine rotation mark

This indicates low/high speed of engine rotation.

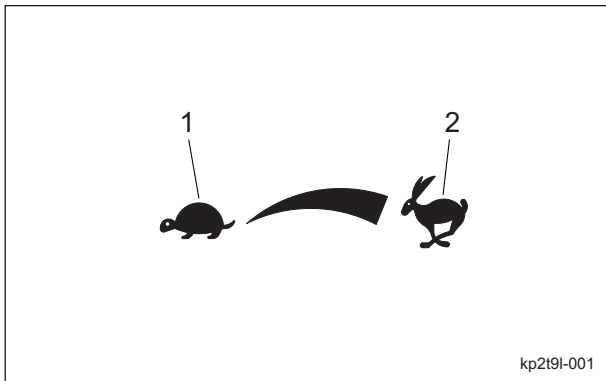

Engine Rotation Mark_001

1	Low speed
2	High speed

Reel Rotation Mark

Reel rotation mark

It illustrates Rotation/Stop of the reel cutter (cutting cylinder).

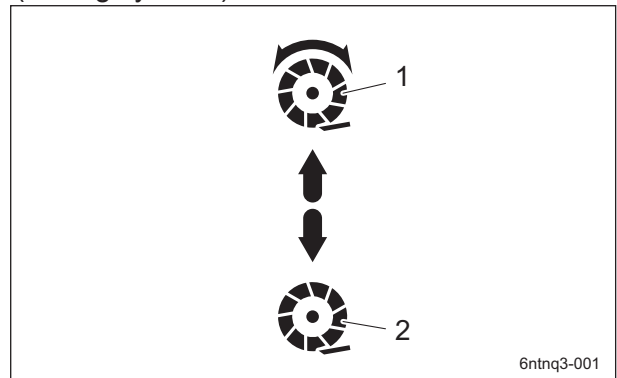

Reel Rotation Mark_001

1	Rotation
2	Stop

Handling Instructions

Mower Unit Up/Down Decal

Decal, mower unit up/down
This indicates the Up/Down positions of the mower unit.

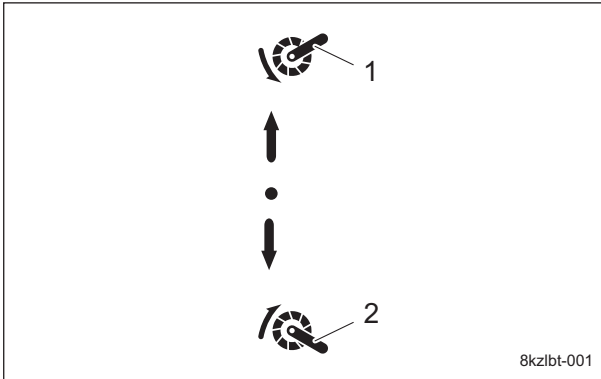

Mower Unit Up/Down Decal_001

1	Down
2	Up

Tilt Steering Decal

K4203001710
Decal, tilt steering
This illustrates the tilt directions of the steering wheel and the locked/free positions.



Tilt Steering Decal_001

Parking Brake Decal

K4203001700
Decal, parking brake
This shows how to lock and release the parking brake.

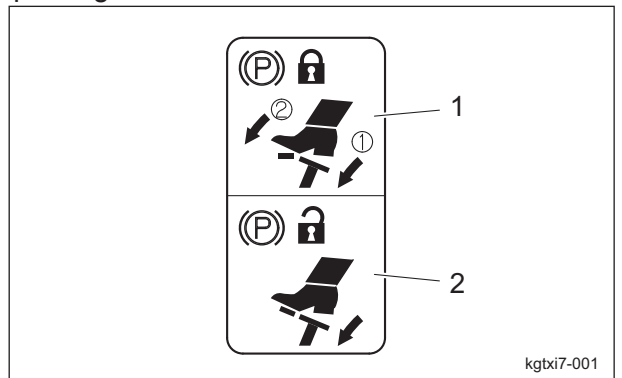

Parking Brake Decal_001

1	Lock
2	Release

Traveling/Working Selector Mark

Traveling/working selector mark
It illustrates the positions where mower units #4 and #5 stop when they are raised. (ON/OFF of slight lift function)

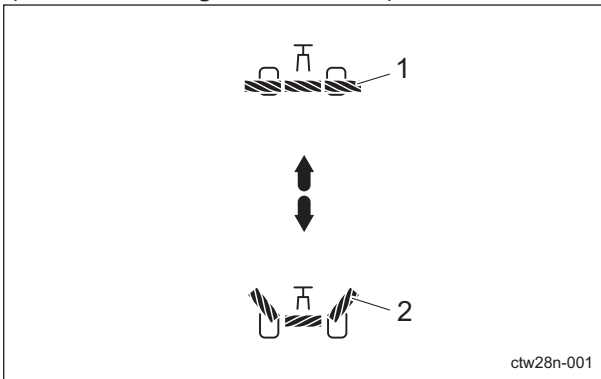

Traveling/Working Selector Mark_001

1	Working
2	Traveling

Handling Instructions

BRAKE Decal

K4203001450
Decal, BRAKE
This indicates brake.



BRAKE Decal_001

Engine Rotation Decal

K4203001660
Decal, engine rotation
This indicates high/low speed.

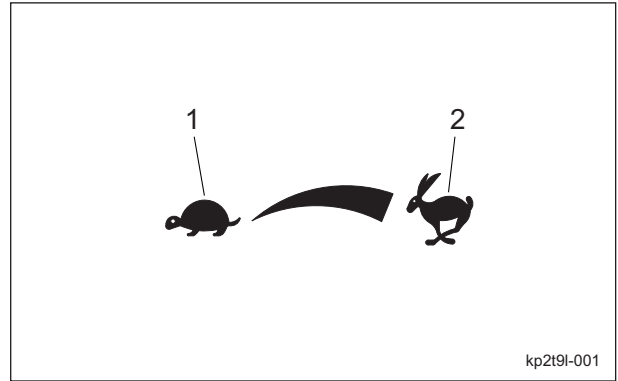

Engine Rotation Decal_001

1	Working speed
2	Traveling speed

FORWARD Decal

K4203001430
Decal, FORWARD
This indicates forward travel.



FORWARD Decal_001

Lever Open/Close Decal

K4203001720
Decal, open/close lever
This indicates lock/release of open/close lever.

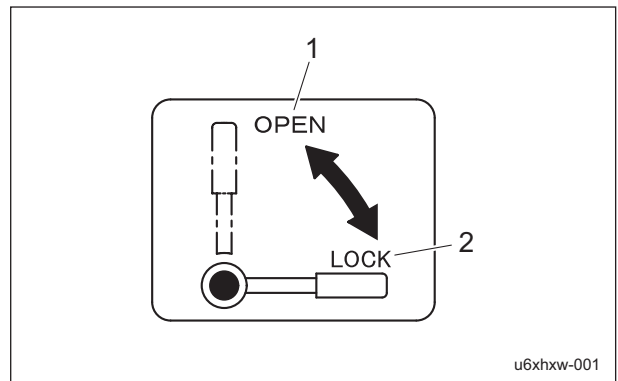

Lever Open/Close Decal_001

1	Release
2	Lock

BACKWARD Decal

K4203001440
Decal, BACKWARD
This indicates backward travel.

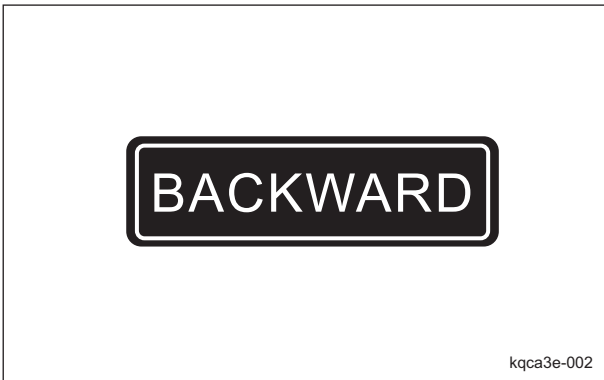

BACKWARD Decal_001

Handling Instructions

Lapping Decal

K4203001590

Decal, lapping

This indicates rotational direction of the reel cutter (cutting cylinder).

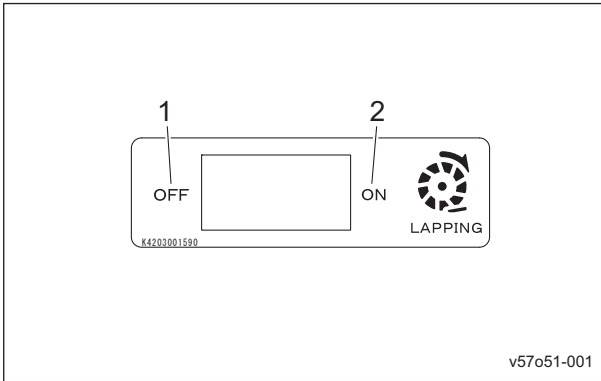

Lapping Decal_001

1	Normal rotation (cutting rotation)
2	Reverse rotation (back lapping rotation)

Reel Rotation Decal

K4203001300

Decal, reel rotation

This indicates rotation of the reel cutter (cutting cylinder).

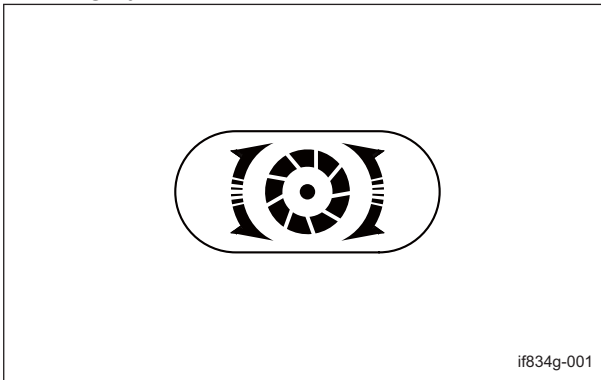

Reel Rotation Decal_001

Reel Stop Decal

K4203001310

Decal, reel stop

This indicates stop of the reel cutter (cutting cylinder).

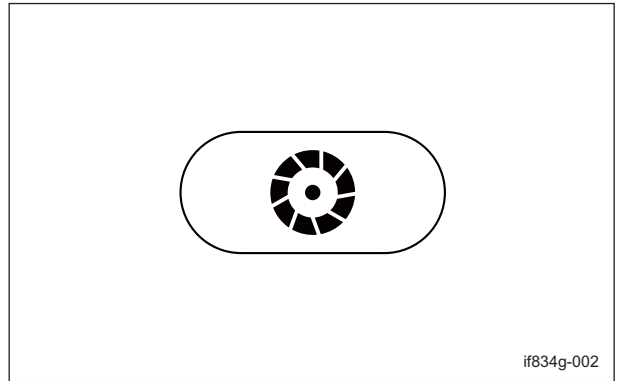

Reel Stop Decal_001

DPF Auto Regeneration Inhibit Switch Decal

Decal, DPF auto regeneration inhibit switch

This indicates switching regarding DPF auto regeneration.

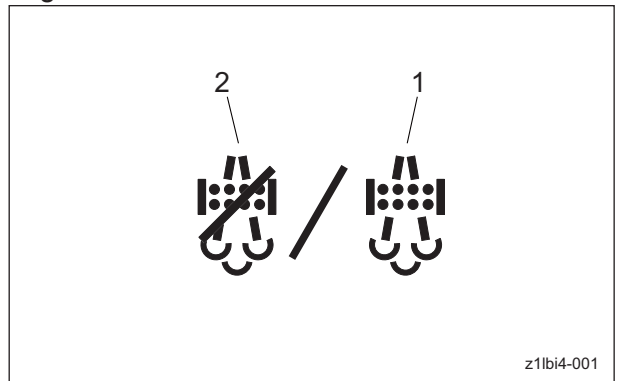

DPF Auto Regeneration Inhibit Switch Decal_001

1	Auto regeneration
2	Auto regeneration inhibit

Handling Instructions

DPF Parked Regeneration Switch Decal

Decal, DPF parked regeneration switch
This indicates the DPF parked regeneration.

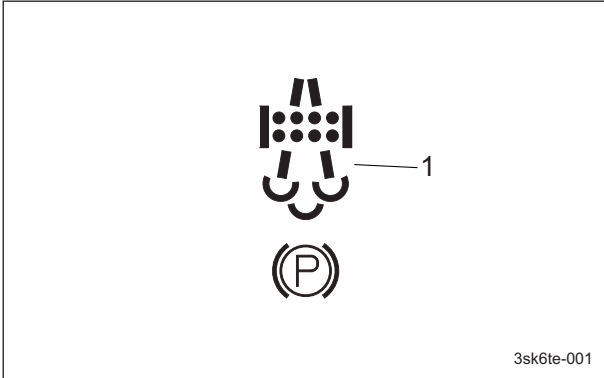

DPF Parked Regeneration Switch Decal_001

1	Parked regeneration (Engaged)
---	-------------------------------

Proximity Sensor

There are four proximity sensors on #1, #2, #4 and #5 mower arm fulcrums. These sensors detect the raised or lowered positions of mower units #1, #2, #4 and #5. The information is related to controlling rotation and stop of the reel cutter (cutting cylinder).

· Mower unit #1

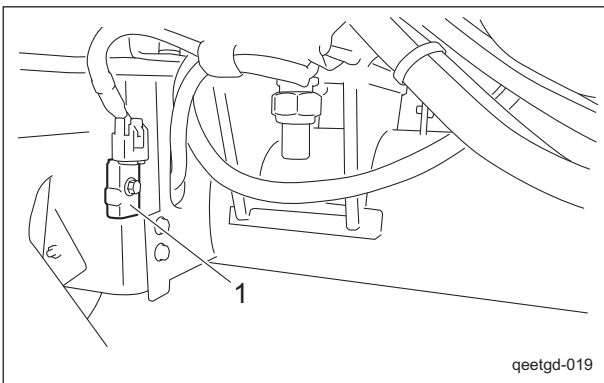

Proximity Sensor_001

1	Proximity sensor
---	------------------

· Mower unit #2

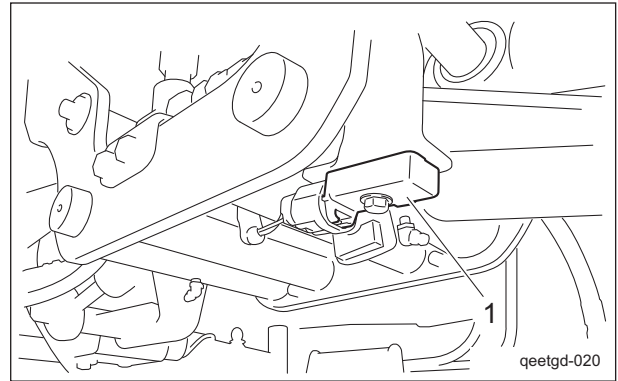

Proximity Sensor_002

1	Proximity sensor
---	------------------

· Mower units #4 and #5

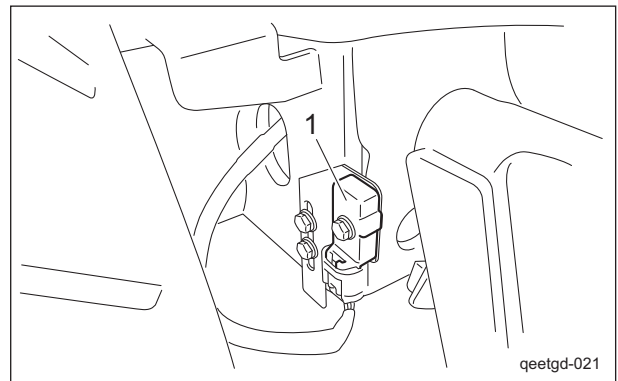

Proximity Sensor_003

1	Proximity sensor
---	------------------

Handling Instructions

Relays

The relay box is located inside the underseat cover. These relays control traveling/working selection, rotation of the reel cutters (cutting cylinders), and mower unit lowering selection. The operating condition can be checked by the illumination of the LEDs.

- LEDs ① and ② light up when the traveling/working selector switch is in the "Working" position and mower units #4 and #5 are raised.
- LED ③ is not used.
- LED ④ lights up when the mower unit up/down lever is in the "Down" position and the traveling/working selector switch is in the "Working" position.
- LEDs ⑤ and ⑥ light up when the reel rotation switch is in the "ON" position and the mower units are lowered.
- LEDs ⑦ and ⑧ light up when the reel reverse switch is in the "ON" position.

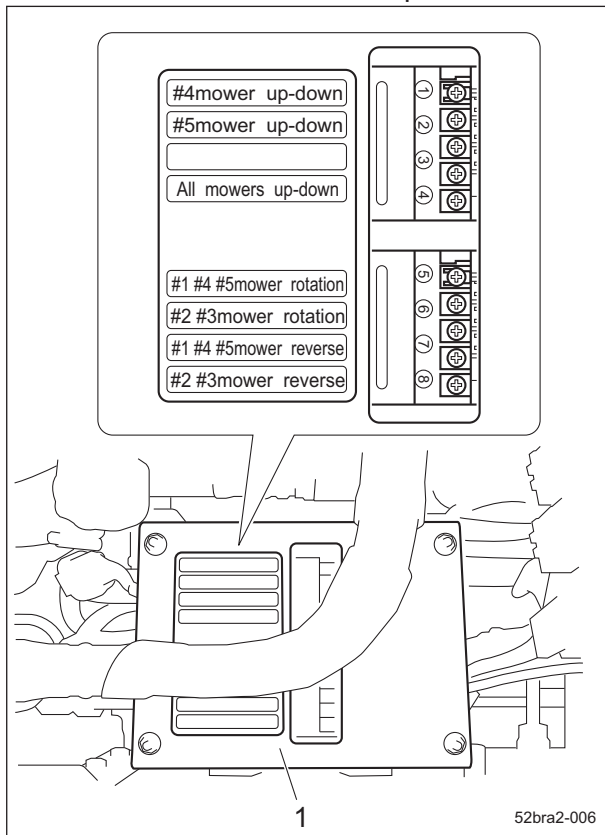

Relays_001

1	Relay box
---	-----------

Light Switch

Note: Depending on the specifications, this function may not be available.

Caution

The lights provide auxiliary lighting. Do not travel or operate the machine at night or under poor visibility.

The light switch is located in the operation panel. When the switch is set to the "Turn on" position, the lights turn on. When it is set to the "Turn off" position, the lights turn off.

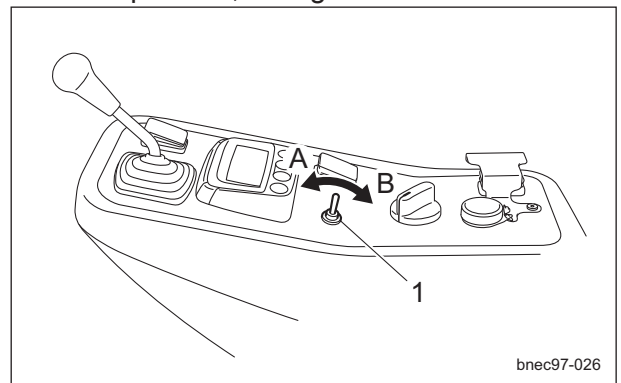

Light Switch_001

1	Light switch
A	Turn on
B	Turn off

Handling Instructions

Traveling/Working Selector Switch

The traveling/working selector switch is located in the operation panel.

This can change the positions where mower units #4 and #5 stop when they are raised.

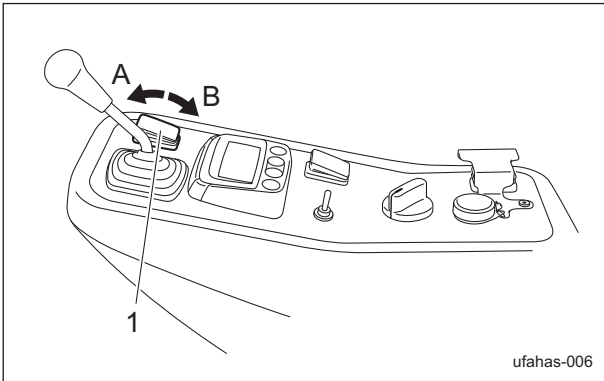

Traveling/Working Selector Switch_001

1	Traveling/working selector switch
A	Working
B	Traveling

When the switch is set to the "Traveling" position, mower units #4 and #5 are raised to their highest positions.

When the switch is set to the "Working" position, mower units #4 and #5 are only raised halfway.

When set to the "Traveling" position

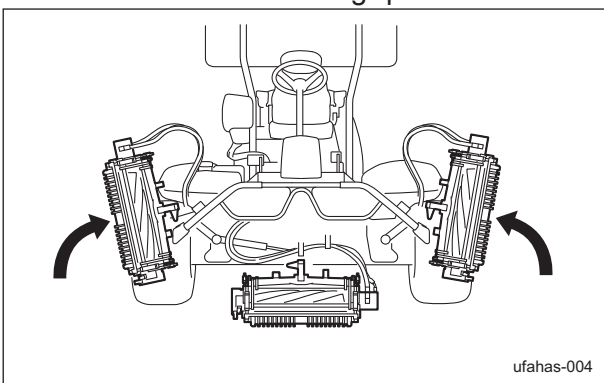

Traveling/Working Selector Switch_002

When set to the "Working" position

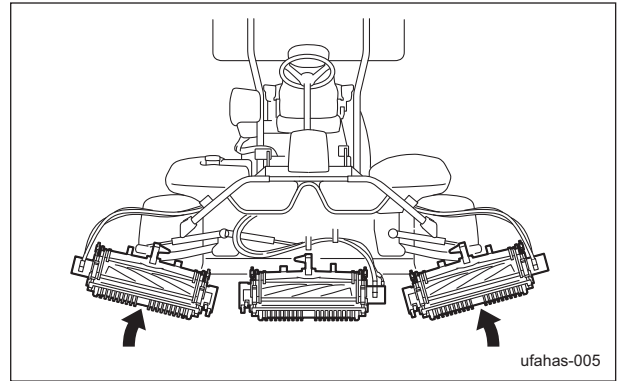

Traveling/Working Selector Switch_003

Reel Rotation Switch



Caution

Set the reel rotation switch to the "Rotation" position immediately before starting cutting work. At all other times, be sure to leave the reel rotation switch set to the "Stop" position.

The reel rotation switch is located in the operation panel and operates rotation of the reel cutters (cutting cylinders) of the mower units.

When the reel rotation switch is set to the "Rotation" position, the reel cutters (cutting cylinders) of all mower units will rotate for cutting work. When the reel rotation switch is set to the "Stop" position, the reel cutters (cutting cylinders) will stop.

Note:

When the mower units are raised, the reel cutters (cutting cylinders) do not rotate, even if the switch is set to the "Rotation" position.

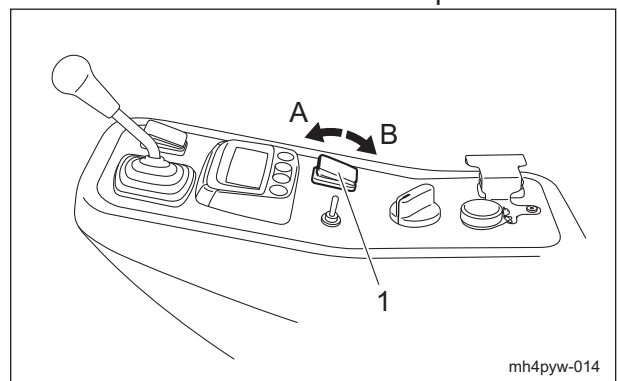

Reel Rotation Switch_001

1	Reel rotation switch
A	Rotation
B	Stop

Handling Instructions

Reel Forward/Reverse Switch

Important

Do not switch between "Forward" and "Reverse" while the reel cutter (cutting cylinder) is rotating. Otherwise, the hydraulic system will malfunction.

Important

If the reel rotation switch is not set to the "Rotation" position, the reel cutter (cutting cylinder) will not rotate.

The reel forward/reverse switch is located inside the underseat cover and switches the rotation direction of the reel cutters (cutting cylinders). When the reel forward/reverse switch is set to the "Forward" position, the reel cutters (cutting cylinders) of all mower units will rotate for cutting work. When the reel forward/reverse switch is set to the "Reverse" position, the reel cutters (cutting cylinders) will rotate in reverse (back lapping rotation).

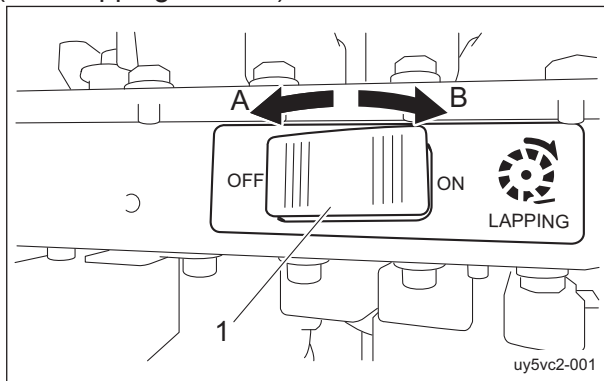

Reel Forward/Reverse Switch_001

1	Reel forward/reverse switch
A	Forward
B	Reverse

Reel Rotation/Stop Switching Lever

Caution

Before operating the reel rotation/stop switching lever, be sure to set the reel rotation switch to the "Stop" position.

The reel rotation/stop switching lever is located on the reel motor attached to each mower unit. It is used during cutting and back lapping. Shift the lever(s) to the "Rotation" position only for the mower unit(s) to be used for cutting or back lapping. Leave the lever(s) for other mower units in the "Stop" position.

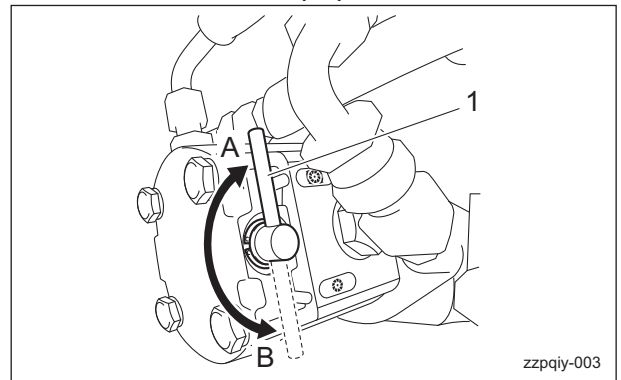

Reel Rotation/Stop Switching Lever_001

1	Reel rotation/stop switching lever
A	Rotation
B	Stop

Mower Lock Lever (Latch)

The mower lock levers (latches) are located in the foot area on the left and right sides and are used when traveling or storing the machine with mower units #4 and #5 raised.

When traveling or storing this machine, hook the mower lock levers (latches) on the arms.

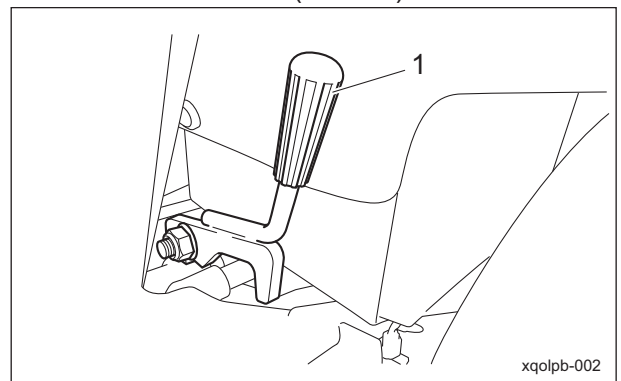

Mower Lock Lever (Latch)_001

1	Mower Lock Lever (Latch)
---	--------------------------

Handling Instructions

Mower Unit Up/Down Lever

Caution

Before raising or lowering the mower units, make sure that there are no people around the machine.

Caution

Be careful of the mower units lowering when the mower unit up/down lever is shifted to the "Down" position and the key switch is turned to the "ON" position while the engine is stopped with the traveling/working selector switch set to the "Working" position.

Important

When the mower lock levers (latches) are engaged, do not operate the mower unit up/down lever.

The mower unit up/down lever is located in the operation panel and raises or lowers the mower units.

When the lever is shifted to the "Down" position, the mower units are lowered. When the lever is shifted to the "Up" position, the mower units are raised.

When the lever is shifted to the "UP" position and then released from the hand, the lever returns to the neutral position.

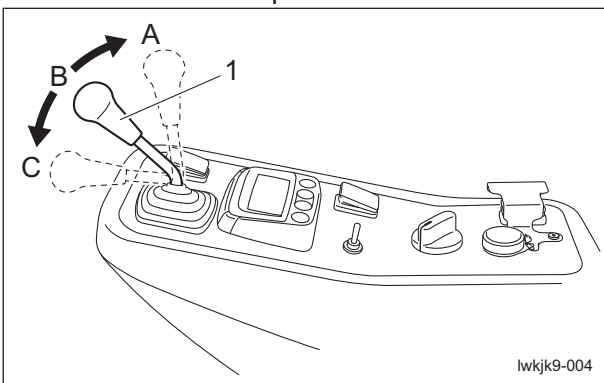

Mower Unit Up/Down Lever_001

1	Mower unit up/down lever
A	Up
B	Neutral
C	Down

Note:

When the mower units are raised, the reel cutters (cutting cylinders) stop rotating even if the reel rotation switch is set to the "Rotation" position.

Throttle Knob

The throttle knob is located in the operation panel and enables you to adjust the engine rpm.

Move the throttle knob toward the "High speed" position to increase the engine rpm, and toward the "Low speed" position to reduce the rpm.

Note:

The factory default maximum engine rotation speed is set to 3,000 rpm.

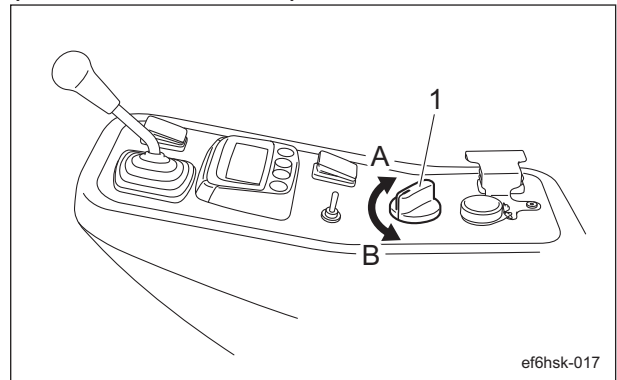

Throttle Knob_001

1	Throttle knob
A	High speed
B	Low speed

Handling Instructions

DPF Auto Regeneration Inhibit Switch

Caution

Normally, set the DPF auto regeneration inhibit switch to "Auto regeneration mode". However, when operating in a location where fires may occur, set the DPF auto regeneration inhibit switch to "Auto regeneration inhibit mode".

Important

The DPF auto regeneration inhibit switch is reset to "Auto regeneration mode" when the engine is started even if the engine was stopped with the DPF auto regeneration inhibit switch set to "Auto regeneration inhibit mode".

The DPF auto regeneration inhibit switch is located in the operation panel. The DPF auto regeneration inhibit switch is the switch for shifting between "Auto regeneration mode" and "Auto regeneration inhibit mode". With the engine running, press this switch to the "Auto regeneration/Auto regeneration inhibit mode" side to shift between "Auto regeneration mode" and "Auto regeneration inhibit mode".

- Auto regeneration mode:
The DPF auto regeneration inhibit switch is reset to "Auto regeneration mode" when the engine is started. In "Auto regeneration mode" regeneration is automatically performed regardless of the main vehicle's travel and stop on the condition that a specific amount of PM is accumulated and the requirements for DPF regeneration are fulfilled.
- Auto regeneration inhibit mode:
In order to set to "Auto regeneration inhibit mode", press the DPF auto regeneration inhibit switch after the engine is started. In "Auto regeneration inhibit mode" PM accumulates in the DPF and PM accumulation level increases. Unless the operator implements regeneration on his own will, regeneration is not performed.

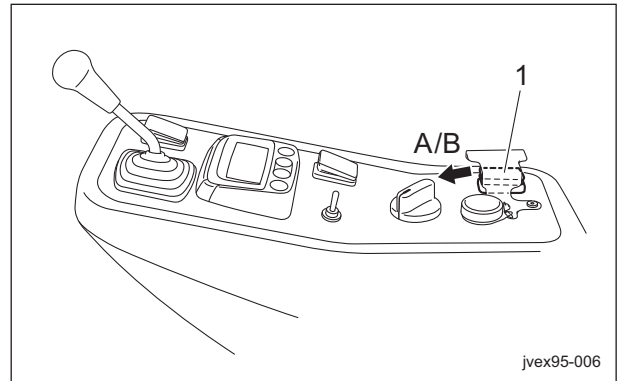

DPF Auto Regeneration Inhibit Switch_001

1	DPF auto regeneration inhibit switch
A	Auto regeneration mode
B	Auto regeneration inhibit mode

When the DPF auto regeneration inhibit switch is pressed and set to "Auto regeneration inhibit mode", the monitor displays Auto regeneration inhibit icon.

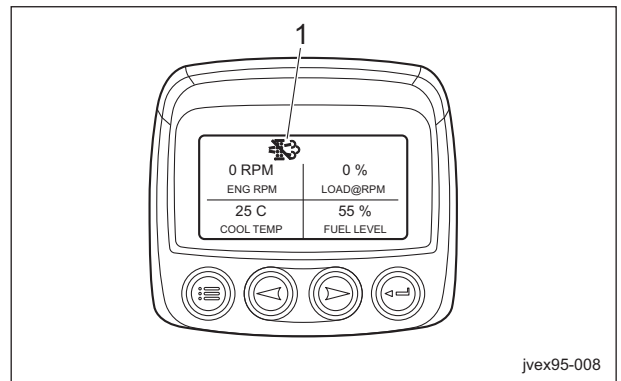

DPF Auto Regeneration Inhibit Switch_002

1	Auto regeneration inhibit icon
---	--------------------------------

Handling Instructions

DPF Parked Regeneration Switch

⚠ Danger

Do not perform DPF regeneration in a location where fires may occur since it will become extremely hot around the exhaust outlet during DPF regeneration.

Important

If parked regeneration is not required, it will not start even if the switch is pressed.

The DPF parked regeneration switch is located in the operation panel.
 The DPF parked regeneration switch is the switch for actuating parked regeneration.
 When the regeneration icon is blinking, press the switch to the "Parked regeneration (actuation)" side to start parked regeneration.

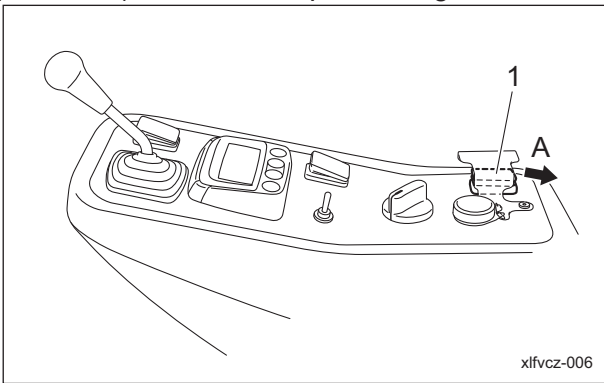

DPF Parked Regeneration Switch_001

1	DPF parked regeneration switch
A	Parked regeneration (actuation)

When parked regeneration starts, Regeneration icon in the monitor display changes from blinking to lighting.

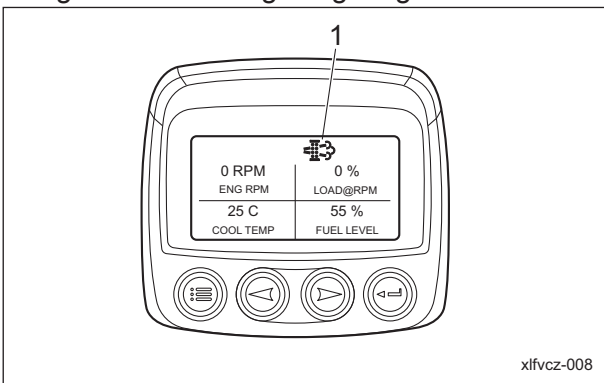

DPF Parked Regeneration Switch_002

1	Regeneration icon
---	-------------------

Traveling Pedal

The traveling pedal is located in the right foot area.
 When forward depressed, the machine travels forward. When backward depressed, the machine travels backward.

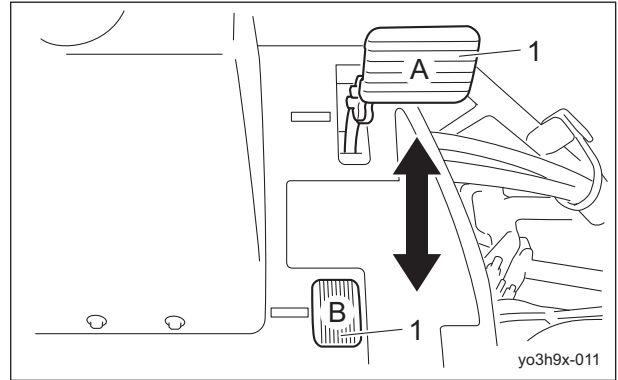

Traveling Pedal_001

1	Traveling pedal
A	Forward
B	Backward

The height and angle of the traveling pedal can be adjusted to fit the operator.

Forward:

The height and angle can be adjusted by changing the installation position of the bolt and spring washer.

Backward:

The height can be adjusted by changing the installation position of the bolt and spring washer.

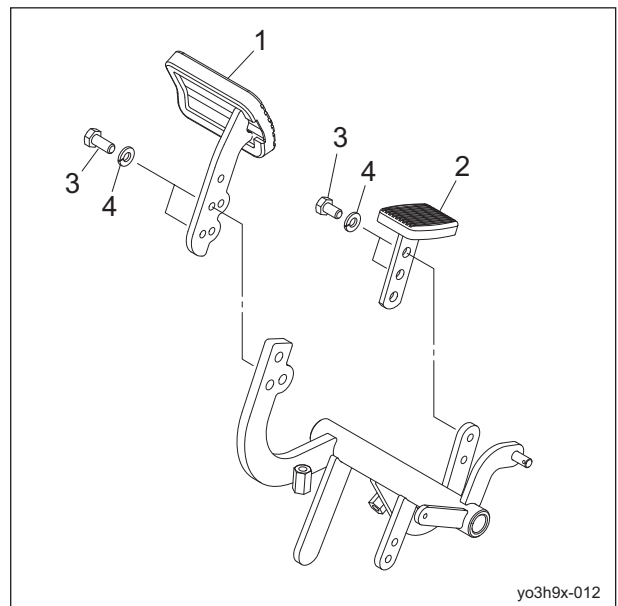

Traveling Pedal_002

Handling Instructions

1	Traveling pedal (forward)
2	Traveling pedal (backward)
3	Bolt
4	Spring washer

Pedal Stopper

The pedal stopper is located in the right foot area. This lever changes the amount that the forward pedal can be depressed.

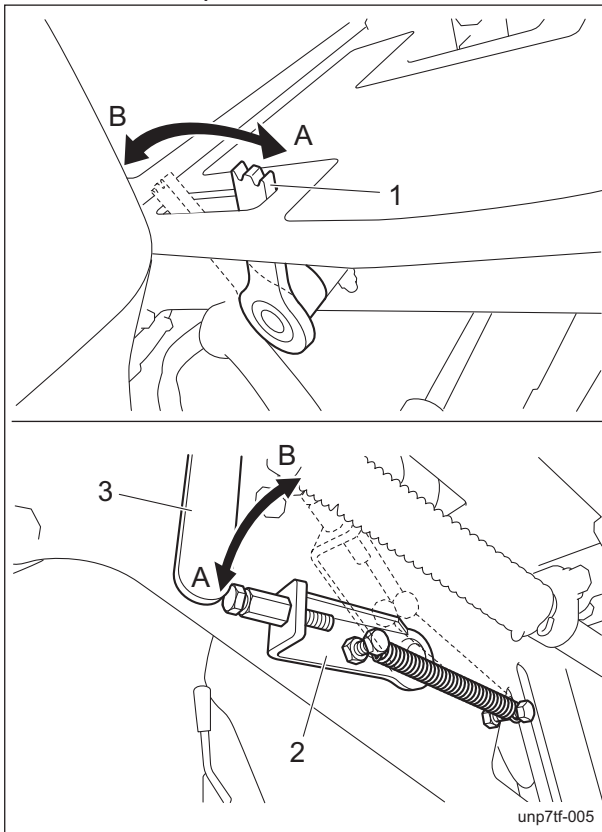

Pedal Stopper_001

1	Pedal stopper
2	Operating speed lock lever
3	Traveling pedal
A	ON
B	OFF

Use the pedal stopper during operation. You can adjust the amount that the forward pedal can be depressed. Loosen the bolt to adjust to 12 km/h or less.

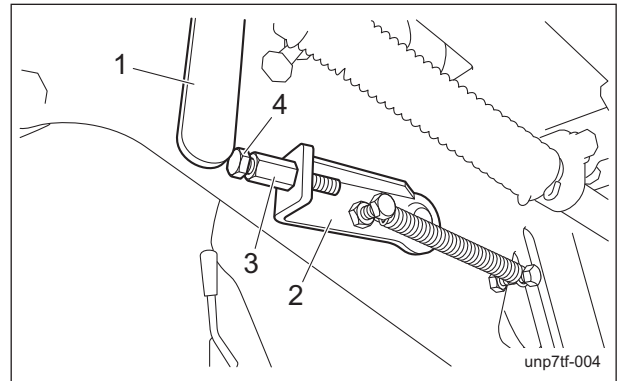

Pedal Stopper_002

1	Traveling pedal
2	Operating speed lock lever
3	Lock nut
4	Bolt

Brake Pedal

⚠ Caution

When leaving the driver's seat, park the machine on a stable, flat surface and be sure to apply the parking brake.

⚠ Caution

Never park the machine on a slope.

The brake pedal is located in the left foot area. To stop the machine, firmly depress the brake pedal.

When parking, depress the locking pedal while firmly depressing the brake pedal to lock it. To release the brake pedal, firmly depress the brake pedal to release the locking pedal.

Note:

Locking the brake pedal can be used as a parking brake.

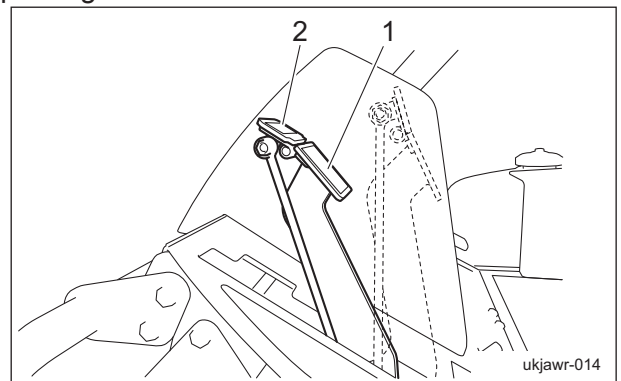

Brake Pedal_001

Handling Instructions

1	Brake pedal
2	Locking pedal

Open-Close Lever

The open-close lever is located at the lower-left side of the seat.

This is used when opening and closing the underseat cover.

When opening the underseat cover, raise the open-close lever to unlock. After closing the underseat cover, lock it.

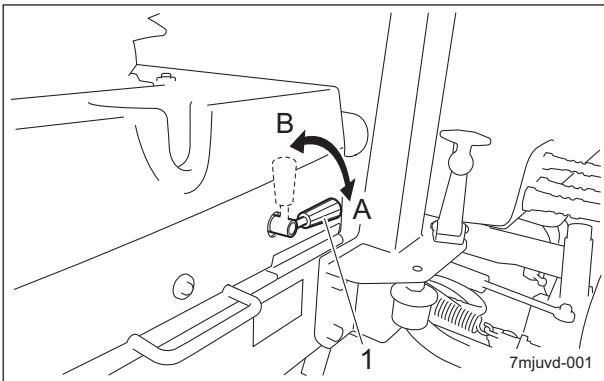

Open-Close Lever_001

1	Open-close lever
A	Lock
B	Unlock

Radiator Cover

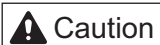

Caution
Do not open the radiator cover in strong winds.

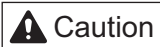

Caution
Be careful not to pinch your fingers when you open or close the cover.

1. Release the rubber catch.
2. Open the radiator cover to the right.

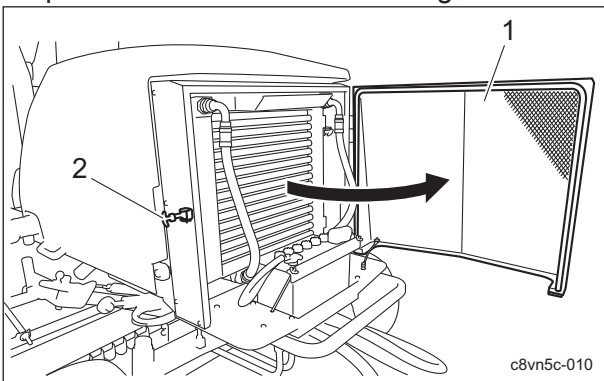

Radiator Cover_001

1	Radiator cover
2	Rubber catch

3. Close the radiator cover slowly.
4. Lock the rubber catch securely.

Hood



Caution
Do not open the hood in strong winds.



Caution
Be careful not to pinch your fingers when you open or close the hood.

1. Remove the nuts and bolts locking the catch clips on the left and right sides of the hood.

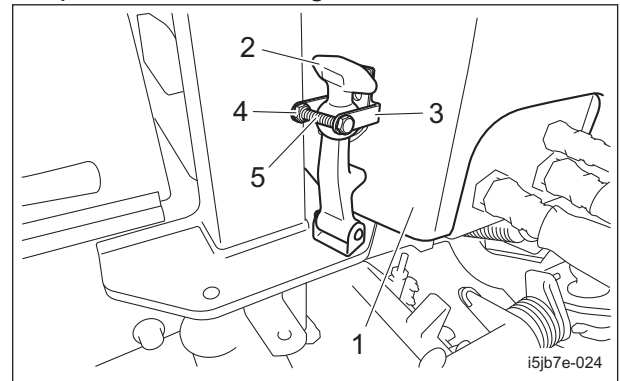

Hood_001

1	Hood
2	Rubber catch
3	Catch clip
4	Nut
5	Bolt

2. Release the rubber catches on the left and right sides.

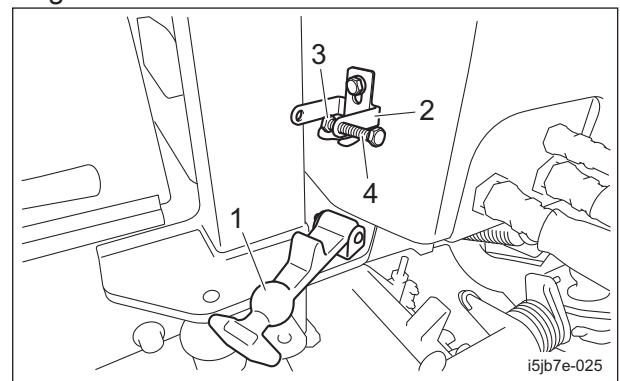

Hood_002

Handling Instructions

1	Rubber catch
2	Catch clip
3	Nut
4	Bolt

3. Make sure that the radiator cover is closed.
4. Lift up the hood.

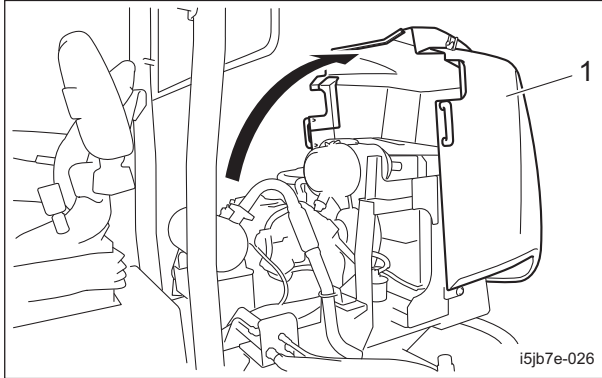

Hood_003

1	Hood
---	------

5. Close the hood slowly.
6. Securely engage the left and right rubber catches.
7. Install the nuts and bolts locking the left and right catch clips.

Underseat Cover

Caution

Be careful not to pinch your fingers when you open or close the cover.

1. Make sure that the steering wheel is raised completely.
2. Move the seat to the center between the forward and backward positions.
3. Tilt the seat backrest forward.

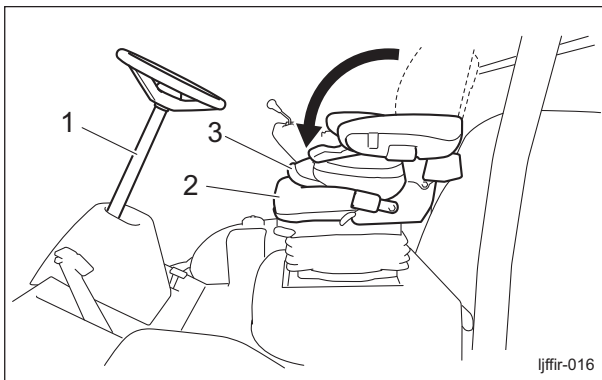

Underseat Cover_001

1	Steering wheel
2	Seat
3	Backrest

4. While unlocking with the open-close lever, grab the grip and tilt the seat to the right to open the underseat cover.

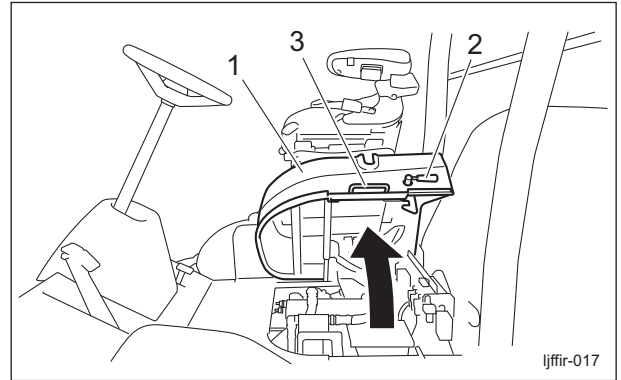

Underseat Cover_002

1	Underseat cover
2	Open-close lever
3	Grip

Step Cover

1. Remove the button head bolts.
2. Remove the step cover.

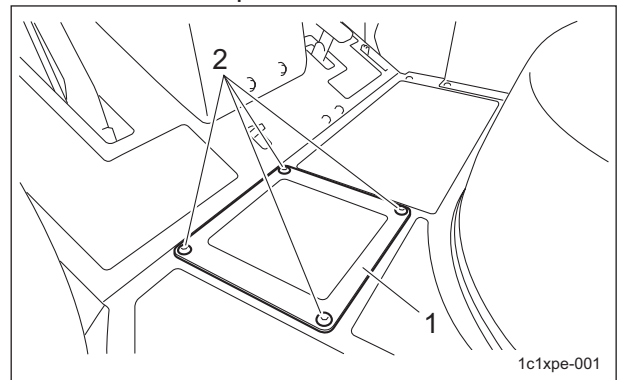

Step Cover_001

1	Step cover
2	Button head bolt

For installation, reverse the removing procedure.

Handling Instructions

Instruments

Description of Monitor

The monitor displays various information about the machine, such as the operating status and fault conditions.

The information of desired items can be confirmed according to operating the keys.

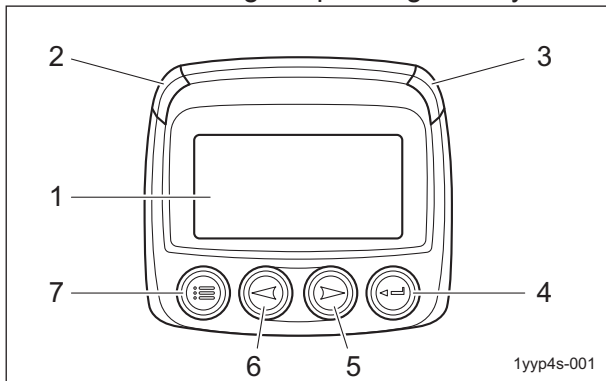

Description of Monitor_001

1	Monitor display
2	LED (yellow)
3	LED (red)
4	Enter key
5	Right arrow key
6	Left arrow key
7	Menu key

1. Monitor display
Displays machine conditions and items.
2. LED (yellow)
Lights up when a malfunction is detected, indicating warning and/or caution on the engine.
3. LED (red)
Lights up when a critical malfunction on the engine is detected.
4. Enter key
Selects the menu or parameter.
Switches between displaying/hiding the current fault code.
5. Right arrow key
Scrolls the screen.
Move the parameter selection to the right or down.
6. Left arrow key
Scrolls the screen.
Move the parameter selection to the left or up.
7. Menu key
Opens or exits the menu.

Displayed Icon

The icon appears at the top of the monitor display.

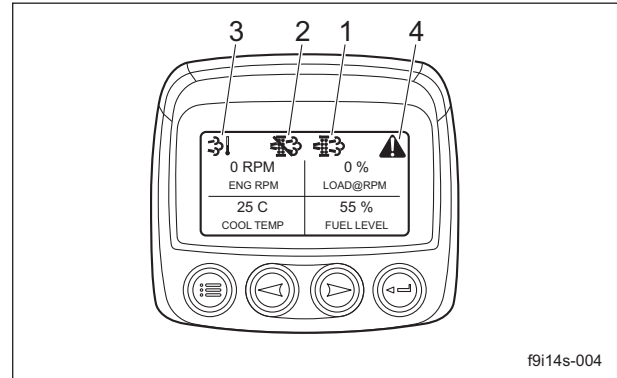

Displayed Icon_001

1	Regeneration icon
2	Auto regeneration inhibit icon
3	High exhaust temperature icon
4	Warning mark

1. Regeneration icon
The regeneration icon appears with DPF regeneration request or during DPF regeneration.
 - DPF regeneration request: Blinking
 - During DPF regeneration: Lighting
2. Auto regeneration inhibit icon
The auto regeneration inhibit icon lights up when the DPF auto regeneration inhibit switch is set to the "Auto regeneration inhibit mode".
3. High exhaust temperature icon
The high exhaust temperature icon lights up when the exhaust temperature reaches 450 °C during DPF regeneration.
4. Warning mark
The warning mark continues to be displayed in the upper right corner of the monitor display if the warning message ignored and the Enter key pressed to hide the message.
 - Service reminders
 - Low fuel level
 - Fault codes

Handling Instructions

Main Menu Items

While any parameter is displayed, press the menu key to display the main menu with the following 11 items.

- GO TO 1-UP DISPLAY / GO TO 4-UP DISPLAY
- LANGUAGES
- STORED CODES
- ENGINE CONFIGURATION
- SETUP 1-UP DISPLAY
- SETUP 4-UP DISPLAY
- SERVICE REMINDERS
- SELECT UNITS
- ADJUST BACKLIGHT
- ADJUST CONTRAST
- UTILITIES

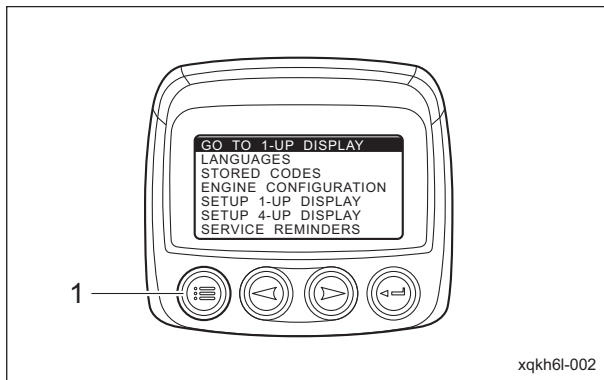

Main Menu Items_001

1	Menu key
---	----------

1-Up Display / 4-Up Display

"GO TO 1-UP DISPLAY" / "GO TO 4-UP DISPLAY" are used to set whether to display parameters individually in a screen or in groups of four per screen.

1. 1-up display

One parameter is displayed individually in the monitor display.

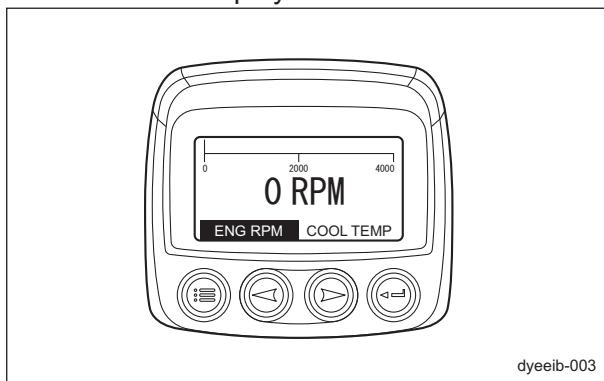

1-Up Display / 4-Up Display_001

2. 4-up display

Four parameters are displayed in the monitor display.

With the 4-up display, a total of 8 parameters are displayed over 2 pages.

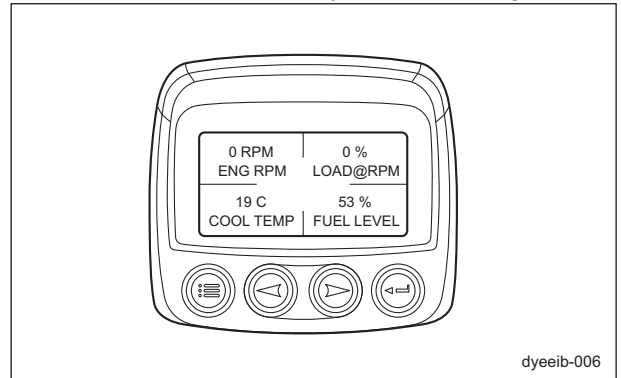

1-Up Display / 4-Up Display_002

Note:

The factory default display is the 4-up display. "GO TO 1-UP DISPLAY" appears in the main menu.

When the 1-up display is set, "GO TO 4-UP DISPLAY" appears in the main menu.

Handling Instructions

■Parameter Items

The parameters and corresponding information that appear in the monitor display are listed below.

No.	Monitor display L	Monitor display S	Description
1	ENGINE SPEED	ENG RPM	Displays the engine rpm.
2	ACTUAL ENGINE TORQUE	ENG TORQ	Displays the actual torque.
3	PERCENT LOAD AT CURRENT RPM	LOAD@RPM	Displays the engine load factor.
4	ACCELRSTOR PEDAL POSITION 1	ACCEL1	Displays the accelerator sensor opening.
5	ENGINE DESIRED OP SPEED	DES ENG SP	Displays the engine rpm required by the ECU.
6	ENGINE COOLANT TEMPERATURE	COOL TEMP	Displays the temperature measured by the coolant temperature sensor.
7	THROTTLE POSITION	THROTTLE	Displays the engine fuel consumption rate.
8	BATTERY POTENTIAL	BAT VOLT	Displays the battery voltage.
9	BAROMETRIC PRESSURE	BARO PRES	Displays the atmospheric pressure measured by the atmospheric pressure sensor.
10	TOTAL ENGINE HOURS	ENG HRS	Displays the total time that the ECU is on (time that the key is in the "ON" position).
11	ENGINE OIL PRESSURE	OIL PRES	Displays the engine oil pressure measured by the oil pressure switch. While the engine is running: Normal=200 kPa, Abnormal=0 kPa
12	DOC INTAKE GAS TEMP	DOC TEMP	Displays the DOC inlet gas temperature measured by the exhaust temperature sensor.
13	EXHAUST FILTER INLET TEMP	EF IN T	Displays the DPF inlet gas temperature measured by the exhaust temperature sensor.
14	DPF DIFFERENCE PRESSURE	DIFF PRES	Displays the pressure difference before and after the DPF, measured by the differential pressure sensor.
15	EXHAUST FILTER OUTLET TEMP	EF OUT T	Displays the DPF outlet gas temperature measured by the exhaust temperature sensor.
16	PARTICULATE TRAP LAMP	PT LAMP	Shows the status of the regeneration icon. Icon not displayed="OFF", Icon blinking="ON BLINK", Icon solid="ON SOLID"
17	DPF STATUS	DPF ST	Shows the status of the DPF. DPF regeneration not needed="REGEN NOT NEEDED" DPF regeneration needed=(Level 1="NEEDED LOWEST", Level 2-3="NEEDED MODERATE", Level 4="NEEDED HIGHEST")
18	DPF ACTIVE REGEN STATUS	DPF AR ST	Shows the DPF regeneration status. Regeneration not needed="INACTIVE", Regeneration needed="NEEDED", Regenerating="ACTIVE"
19	DPF REGEN INHIBIT STATUS	INHIBIT ST	Shows the ECU auto regeneration inhibited status. Auto regeneration inhibit switch off="OFF", Auto regeneration inhibit switch on="ON"

Handling Instructions

No.	Monitor display L	Monitor display S	Description
20	DPF REGENERATION INHIBITED SW	DPF INHIB SW	Shows the status of auto regeneration inhibit switch. Auto regeneration inhibit switch off="OFF", Auto regeneration inhibit switch on="ON"
21	EXHAUST TEMP LAMP	EXH T LAMP	Displays the condition of the exhaust temperature. 450 °C or more="ON", 450 °C or less="OFF"
22	MACHINE HOURS	MACH HRS	Displays the total operating time of the machine (time that the engine was actually running).
23	FUEL LEVEL	FUEL LEVEL	Displays the quantity of fuel remaining in the fuel tank.
24	BATTERY POTENTIAL VOLTAGE	BAT VOLT	Displays the battery potential voltage.

Note:

When display settings are being specified, the parameters appear on "Monitor display L".

At all other times, the parameters appear on "Monitor display S".

Handling Instructions

Language

With "LANGUAGES", the language used in the monitor display can be set to either of the following two.

- ENGLISH
- JAPANESE

An asterisk appears at the right of the currently selected language.

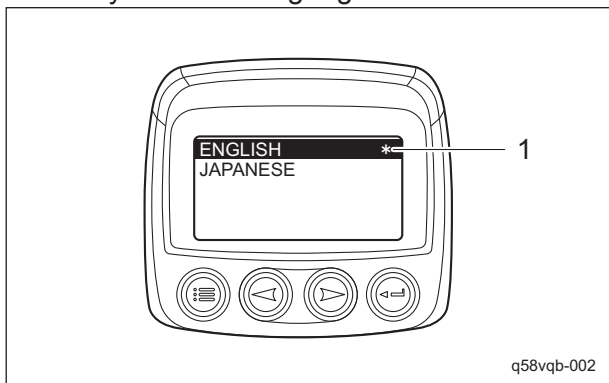

q58vqb-002

Language_001

1	Asterisk
---	----------

Note:

The factory default language is "ENGLISH".

Fault Code Log

This function is not available.

Engine Configuration

This function is not supported.

1-Up Display Setup

With "SETUP 1-UP DISPLAY", the displayed parameters can be reset to the factory defaults, or the necessary parameters to be displayed can be selected.

The following 3 items appear when "SETUP 1-UP DISPLAY" is selected.

- USE DEFAULTS
- CUSTOM SETUP
- AUTOMATIC SCAN

■Use Defaults

With "USE DEFAULTS", the 1-up display parameters return to the factory defaults.

1. Press the menu key. After the main menu appears, use the arrow keys to highlight "SETUP 1-UP DISPLAY", and then press the Enter key.

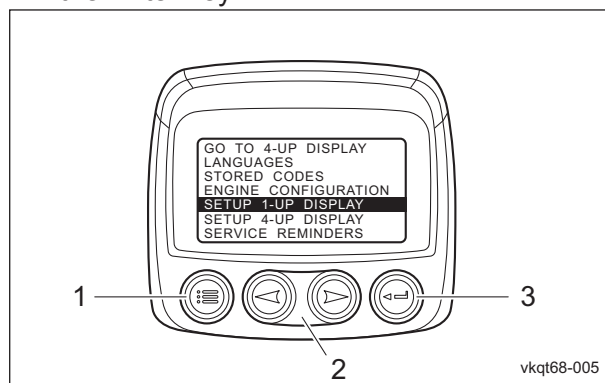

vkqt68-005

Use Defaults_001

1	Menu key
2	Arrow keys
3	Enter key

2. Highlight "USE DEFAULTS", and then press the Enter key.

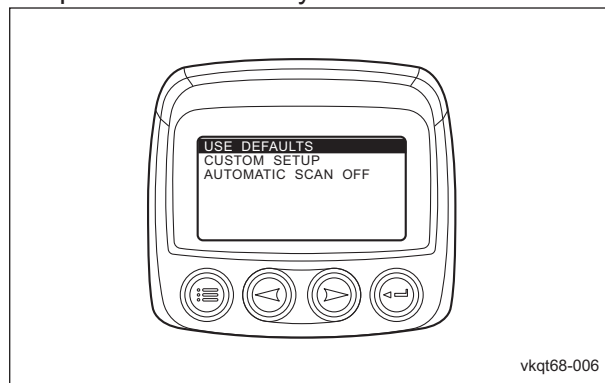

vkqt68-006

Use Defaults_002

Handling Instructions

3. "RESTORED TO DEFAULTS" appears in the monitor display, and the parameters are reset to the factory defaults of the following 10 items.

- [1] ENGINE SPEED
- [2] ENGINE COOLANT TEMPERATURE
- [3] FUEL LEVEL
- [4] ENGINE OIL PRESSURE
- [5] MACHINE HOURS
- [6] BATTERY POTENTIAL
- [7] DPF ACTIVE REGEN STATUS
- [8] DOC INTAKE GAS TEMP
- [9] EXHAUST FILTER INLET TEMP
- [10] EXHAUST FILTER OUTLET TEMP

4. After the settings have been applied, pressing the menu key once returns to the main menu, and pressing the key again returns to the 1-up/4-up display screen.

■Custom Setup

With "CUSTOM SETUP", the type and number of parameters as well as their display order can be specified.

1. Press the menu key. After the main menu appears, use the arrow keys to highlight "SETUP 1-UP DISPLAY", and then press the Enter key.

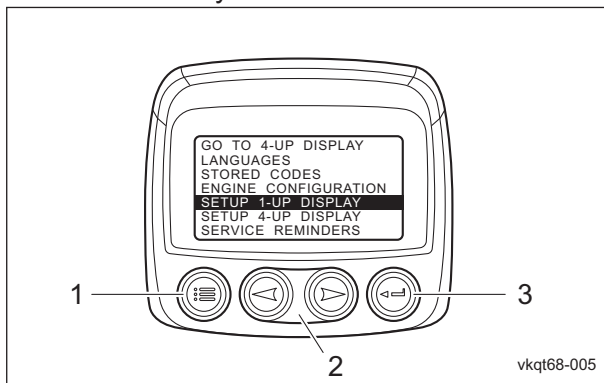

Custom Setup_001

1	Menu key
2	Arrow keys
3	Enter key

2. Highlight "CUSTOM SETUP", and then press the Enter key.
The list of parameters appears.

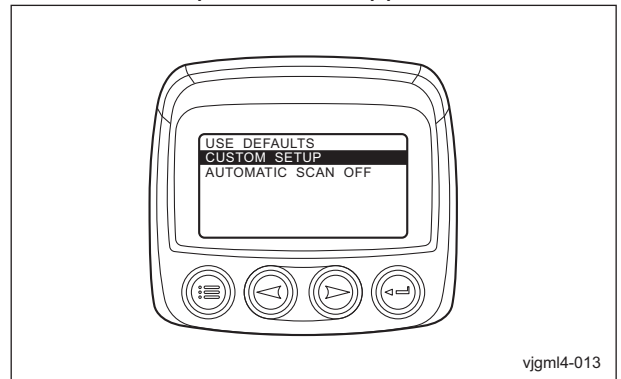

Custom Setup_002

3. Change the parameters.

[1] To add a parameter

a. Use the arrow keys to highlight the parameter to be added, and then press the Enter key.

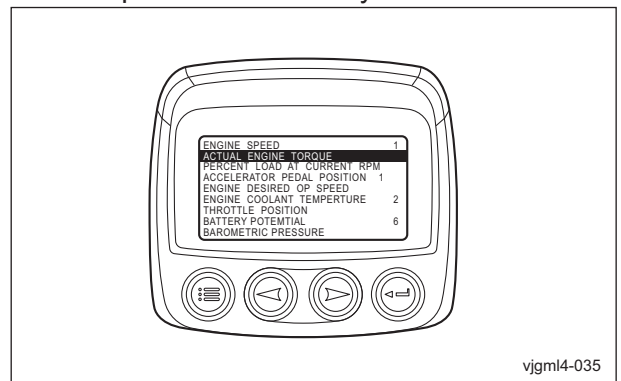

Custom Setup_003

b. A number appears at the right of the selected parameter. This number indicates the display order for the parameter.

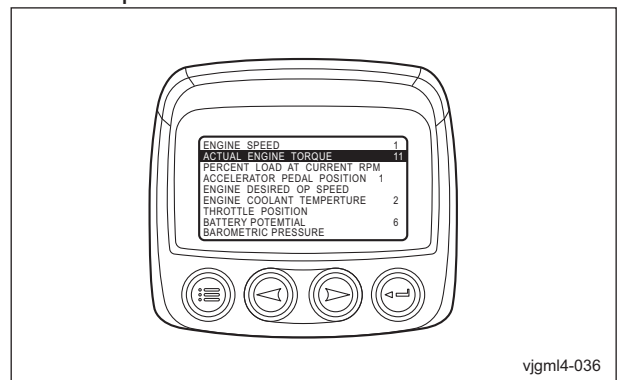

Custom Setup_004

Handling Instructions

- [2] To deselect a parameter and remove it from the list of displayed parameters
- a. Highlight the parameter, and then press the Enter key.

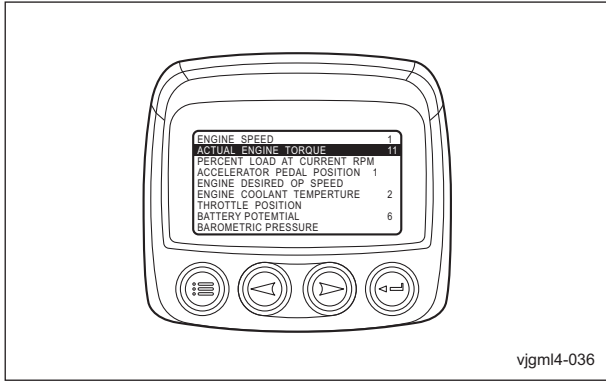

Custom Setup_005

- b. Check that the number at the right of the parameter disappeared.

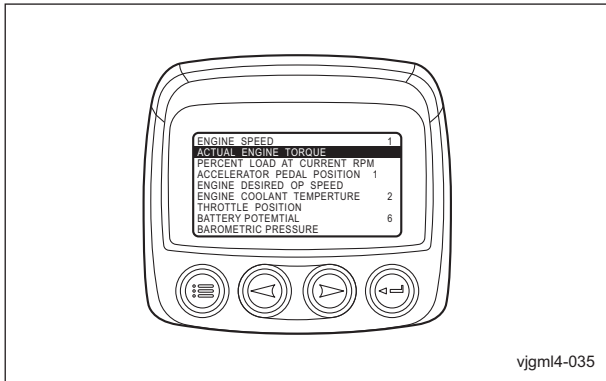

Custom Setup_006

4. After the settings have been applied, pressing the menu key once returns to the main menu, and pressing the key again returns to the 1-up/4-up display screen.

■ Automatic Scan

With "AUTOMATIC SCAN", the 1-up display can be set to automatically scroll through the selected parameters one by one.

1. Press the menu key.
After the main menu appears, use the arrow keys to highlight "SETUP 1-UP DISPLAY", and then press the Enter key.

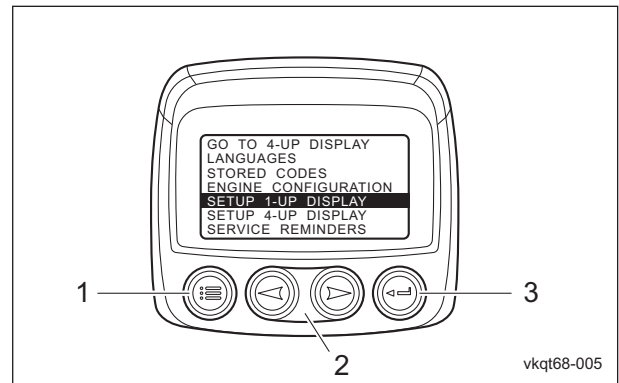

Automatic Scan_001

1	Menu key
2	Arrow keys
3	Enter key

2. When "AUTOMATIC SCAN ON" appears, the parameters are scrolled automatically. For manual scrolling, highlight "AUTOMATIC SCAN ON", and then press the Enter key.
It turns into "AUTOMATIC SCAN OFF" and the parameters will be scrolled manually.

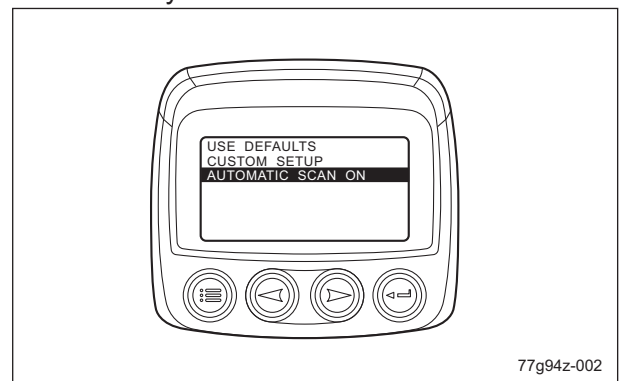

Automatic Scan_002

3. After the settings have been applied, pressing the menu key once returns to the main menu, and pressing the key again returns to the 1-up/4-up display screen.

Note:

When the parameters are scrolled automatically, press the Enter key once to pause scrolling.
When scrolling is paused, press the Enter key once to restart scrolling.

Handling Instructions

4-Up Display Setup

With "SETUP 4-UP DISPLAY", the displayed parameters can be reset to the factory defaults, or the monitor display of selected, necessary parameters can be set up. The following 2 items appear when "SETUP 4-UP DISPLAY" is selected.

- USE DEFAULTS
- CUSTOM SETUP

■Use Defaults

With "USE DEFAULTS", the 4-up display parameters return to the factory defaults.

1. Press the menu key.

After the main menu appears, use the arrow keys to highlight "SETUP 4-UP DISPLAY", and then press the Enter key.

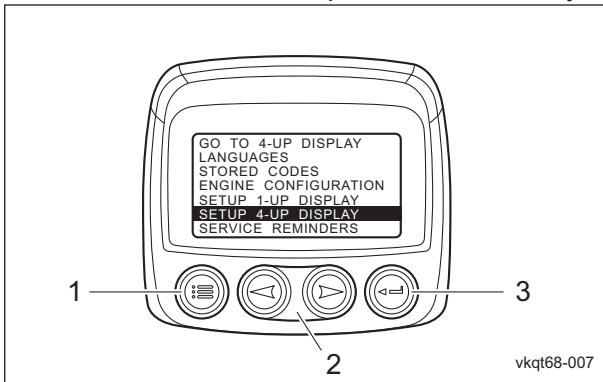

Use Defaults_001

1	Menu key
2	Arrow keys
3	Enter key

2. Highlight "USE DEFAULTS", and then press the Enter key.

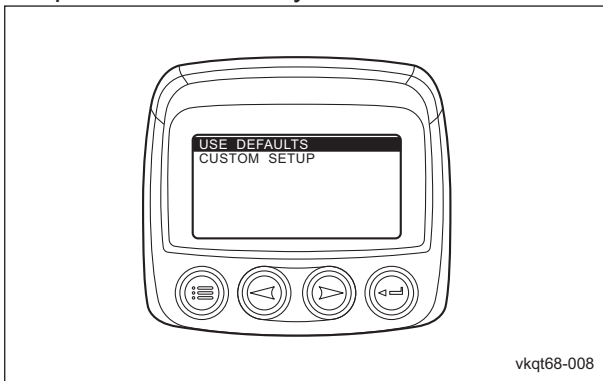

Use Defaults_002

3. "RESTORED TO DEFAULTS" appears in the monitor display, and the parameters are reset to the factory defaults of the following 8 items.

- First page
 - [1] ENGINE SPEED
 - [2] ENGINE COOLANT TEMPERATURE
 - [3] LOAD@RPM
 - [4] FUEL LEVEL
- Second page
 - [1] ENGINE OIL PRESSURE
 - [2] MACHINE HOURS
 - [3] BATTERY POTENTIAL
 - [4] DPF STATUS

4. After the settings have been applied, pressing the menu key once returns to the main menu, and pressing the key again returns to the 1-up/4-up display screen.

■Custom Setup

With "CUSTOM SETUP", the type and number of parameters as well as their display order can be specified.

1. Press the menu key. After the main menu appears, use the arrow keys to highlight "SETUP 4-UP DISPLAY", and then press the Enter key.

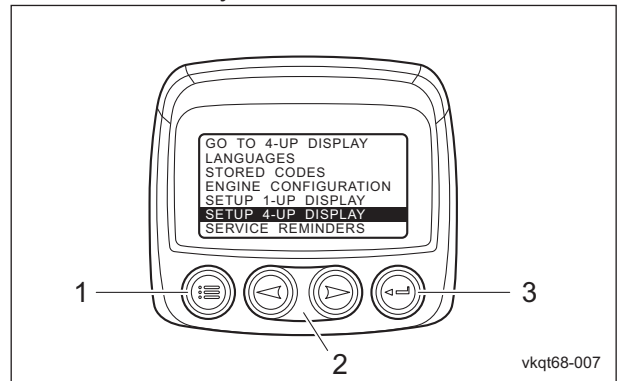

Custom Setup_001

1	Menu key
2	Arrow keys
3	Enter key

Handling Instructions

2. Highlight "CUSTOM SETUP", and then press the Enter key.

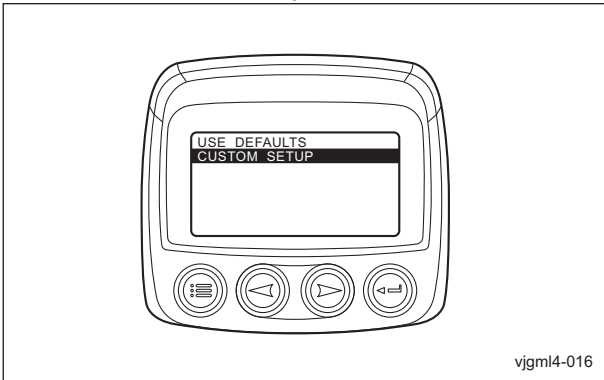

Custom Setup_002

3. Select the page.

[1] Check that the values for the four parameters are highlighted.

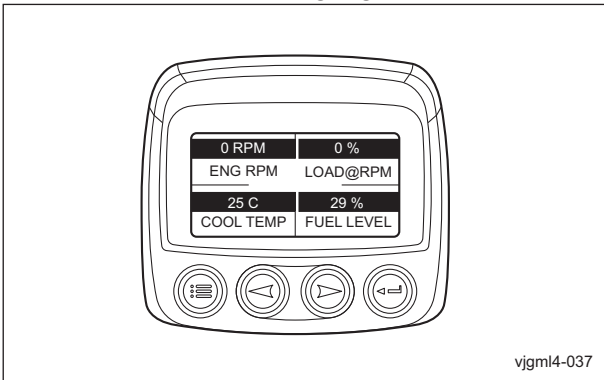

Custom Setup_003

[2] Use the arrow keys to display the page to be changed, and then press the Enter key.

4. Change the parameters.

[1] Check that the value for one parameter is highlighted.

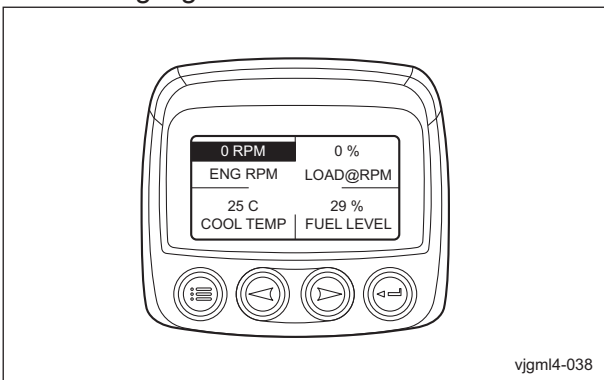

Custom Setup_004

[2] Use the arrow keys to highlight the value of the parameter to be changed, and then press the Enter key.

[3] The parameters appear.
The number at the right of the parameter indicates the location in the 4-up display.
1=Upper left
2=Lower left
3=Upper right
4=Lower right

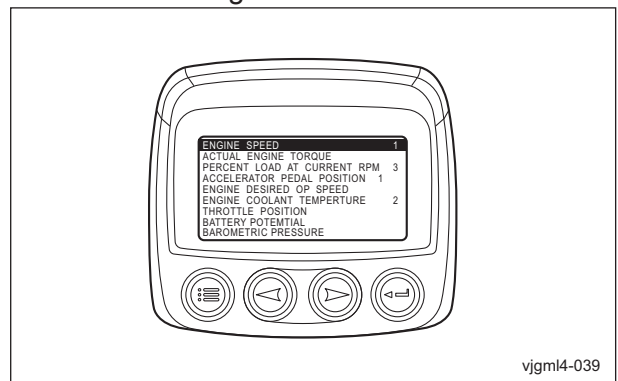

Custom Setup_005

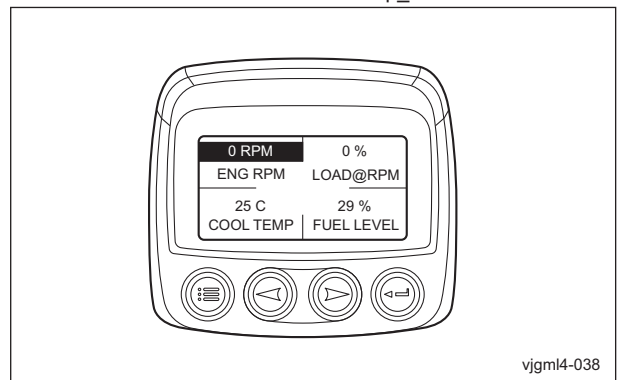

Custom Setup_006

[4] To change to a different parameter
a. Use the arrow keys to highlight the parameter to be selected, and then press the Enter key.

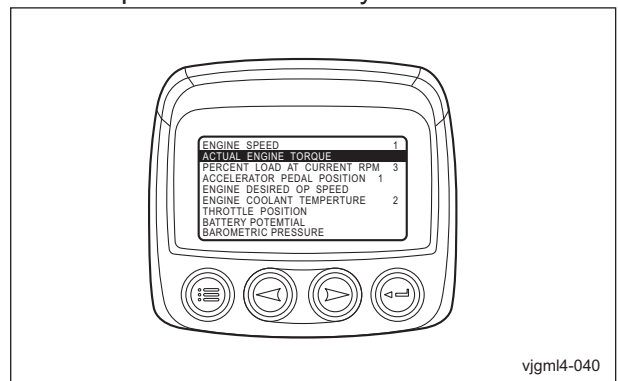

Custom Setup_007

Handling Instructions

b. Check that a number appeared to the right of the selected parameter.

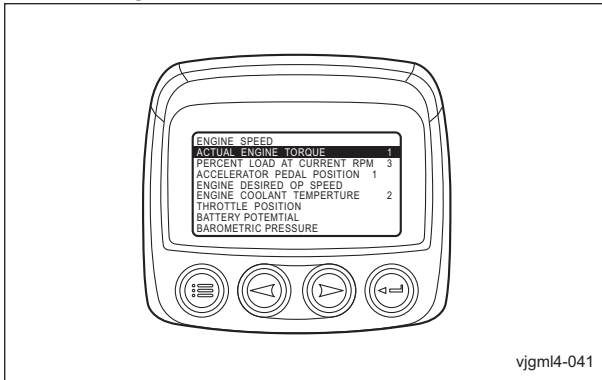

Custom Setup_008

b. Check that the number at the right of the parameter disappeared.

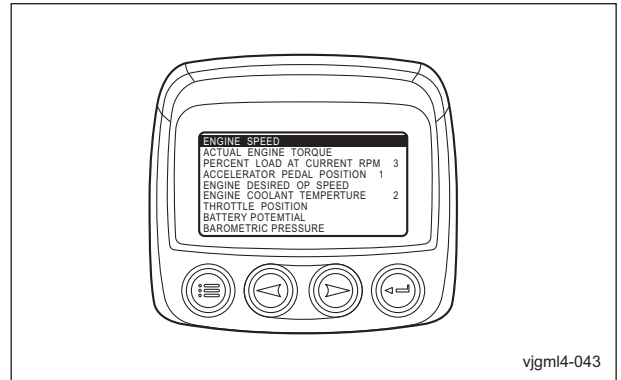

Custom Setup_011

c. Press the menu key and check that the parameter has changed.

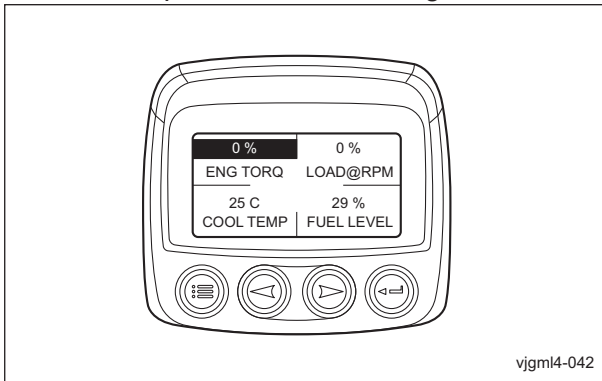

Custom Setup_009

c. Press the menu key and check that the parameter has changed to "EMPTY".

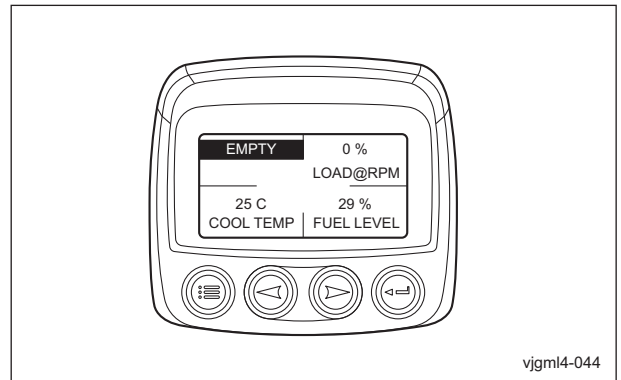

Custom Setup_012

[5] To deselect a parameter and remove it from the list of displayed parameters

a. Highlight the parameter to be removed, and then press the Enter key.

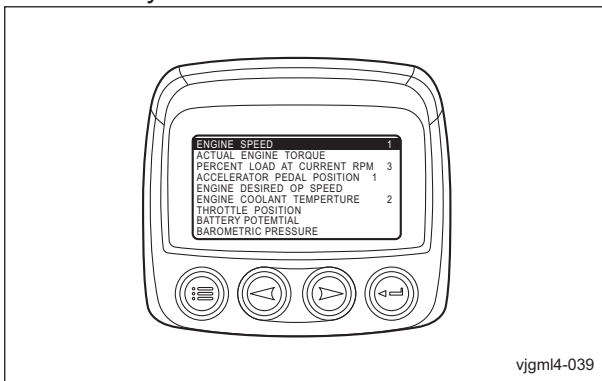

Custom Setup_010

5. Pressing the menu key once returns to the display for selecting the page.
6. To change other parameters, repeat steps 3 to 5.

Handling Instructions

Service Reminders

With "SERVICE REMINDERS", the notification of replacement time for the following 5 consumables can be specified.

- Engine oil
- Engine oil filter
- Hydraulic oil
- Hydraulic oil filter
- Air cleaner

The following 2 items appear when "SERVICE REMINDERS" is selected.

- RESET REMINDERS
- MODIFY REMINDERS

■Reset Reminders

With "RESET REMINDER", displayed remaining time can be reset to the time specified with "MODIFY REMINDERS".

1. Press the menu key.

After the main menu appears, use the arrow keys to highlight "SERVICE REMINDERS", and then press the Enter key.

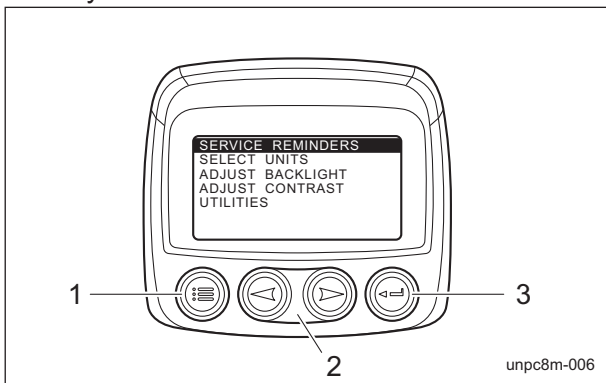

Reset Reminders_001

1	Menu key
2	Arrow keys
3	Enter key

2. Highlight "RESET REMINDER", and then press the Enter key.

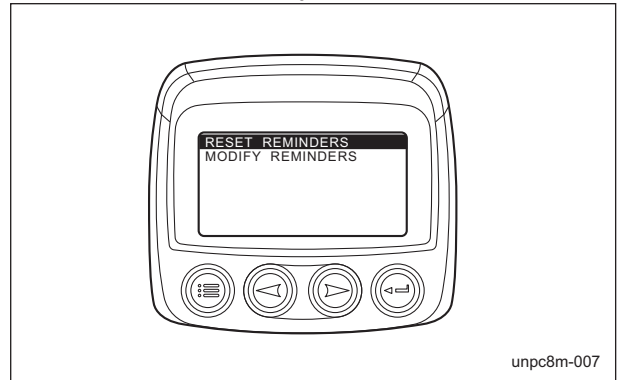

Reset Reminders_002

3. Use the arrow keys to highlight the item to be changed, and then press the Enter key. A plus appears at the right of the currently selected items.

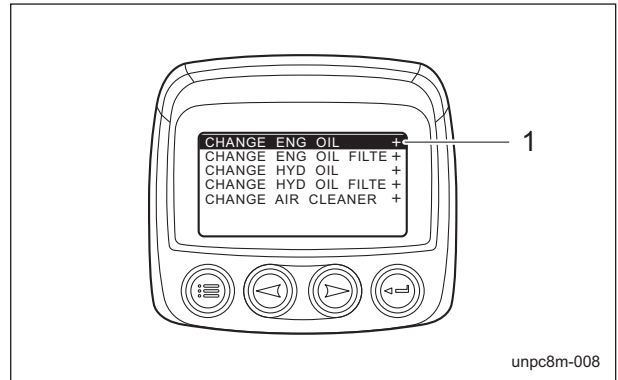

Reset Reminders_003

1	Plus
---	------

4. The remaining time for the selected item appears.

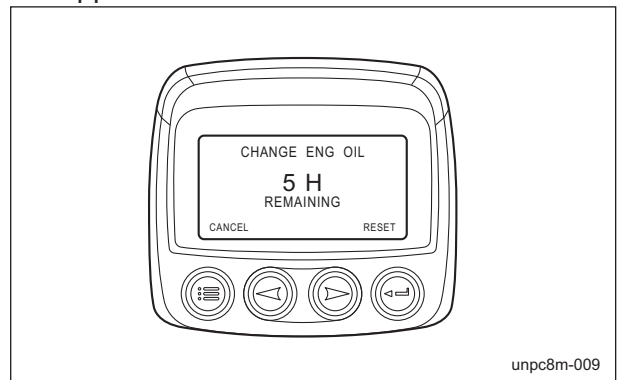

Reset Reminders_004

[1] To reset the remaining time to the specified time, press the Enter key.

Handling Instructions

[2] "RESET SERVICE REMINDER?" appears.
 To reset, press the Enter key.
 To cancel resetting, press the menu key.



Reset Reminders_005

5. The screen for selecting the item appears.

■Modify Reminders

With "MODIFY REMINDERS", the replacement time period for consumables can be specified.

The replacement time period is not configured at the factory.

Configure as necessary.

The replacement time period should be in accordance with the maintenance schedule.

1. Press the menu key.

After the main menu appears, use the arrow keys to highlight "SERVICE REMINDERS", and then press the Enter key.

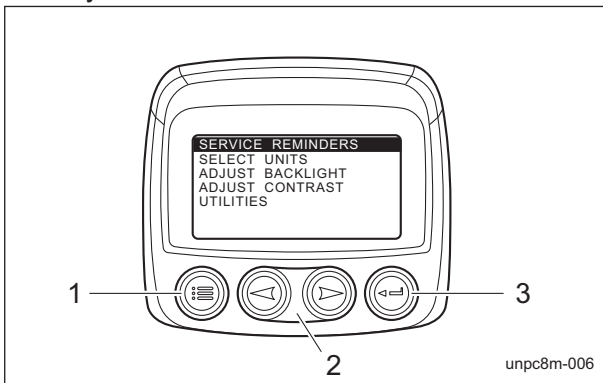

Modify Reminders_001

1	Menu key
2	Arrow keys
3	Enter key

2. Highlight "MODIFY REMINDERS", and then press the Enter key.



Modify Reminders_002

3. Use the arrow keys to highlight the item to be changed, and then press the Enter key.

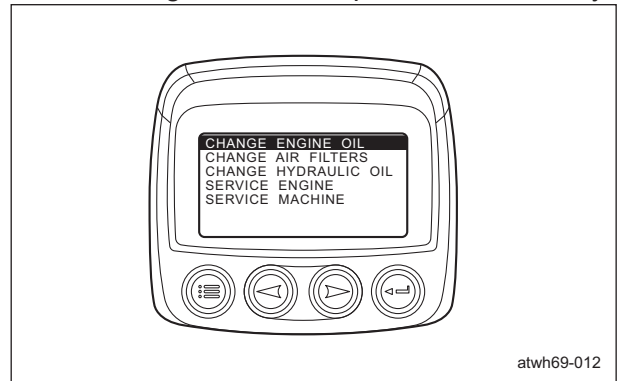

Modify Reminders_003

4. The replacement time period for the selected item appears.

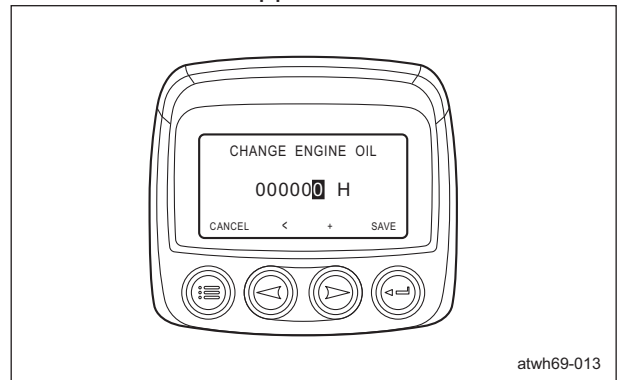

Modify Reminders_004

Handling Instructions

Handling Instructions

5. Highlight the digit to be changed.
Press the right arrow key to increase the number. Press the left arrow key to change the digit.

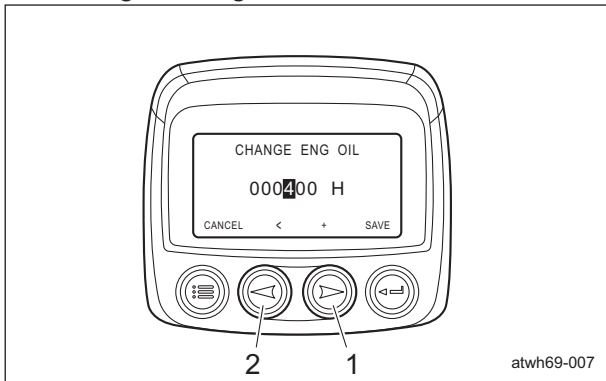

Modify Reminders_005

1	Right arrow key
2	Left arrow key

8. The display for selecting the item appears.
A plus sign appears on the right side of the item with the replacement time period configured.

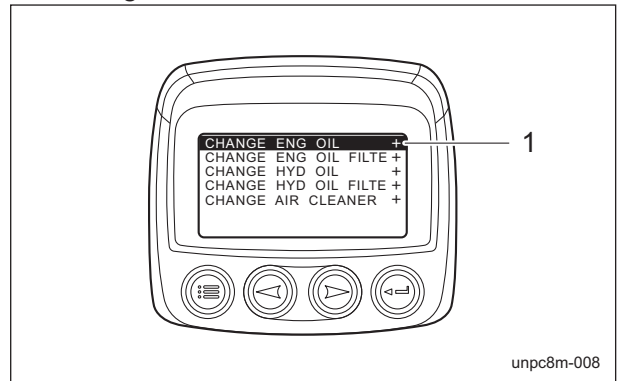

Modify Reminders_007

1	Plus sign
---	-----------

6. To save the specified time period, press the Enter key.
7. "MODIFY SERVICE REMINDER?" appears.
To save the changes, press the Enter key.
To cancel the changes, press the menu key.

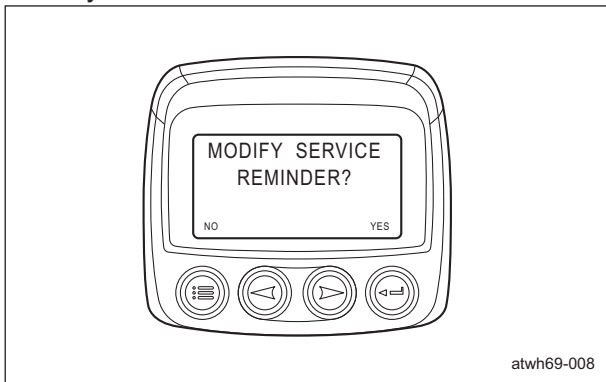

Modify Reminders_006

■Reminder Display

Important

If a warning message appears, stop operation and then perform the replacement procedure.

1. When the specified replacement time period for a consumable has passed, a warning message appears in the monitor display and the LED (yellow) lights up.

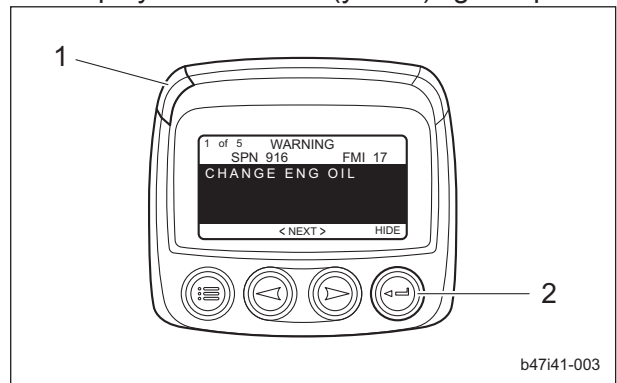

Reminder Display_001

1	LED (yellow)
2	Enter key

2. Pressing the Enter key changes the screen from the warning message to the parameter display.

Handling Instructions

3. A warning mark appears in the upper-right corner of the monitor display.

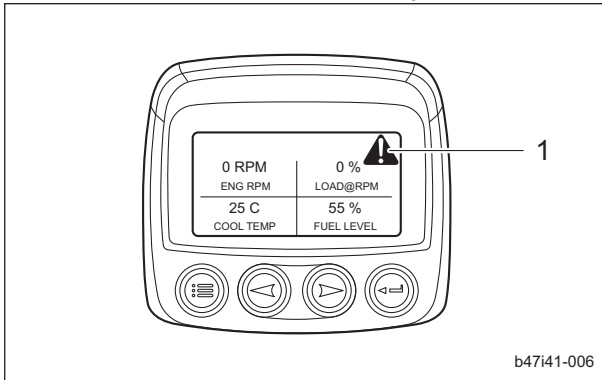

Reminder Display_002

1	Warning mark
---	--------------

4. Change the replacement time period of consumables with "RESET REMINDERS" or "MODIFY REMINDERS".

When the replacement time period is changed, the warning message and mark disappear.

Select Units

With "SELECT UNITS", the units of parameter values can be set to any of the following three formats.

- ENGLISH
- METRIC KPA
- METRIC BAR

An asterisk appears at the right of the currently selected unit.

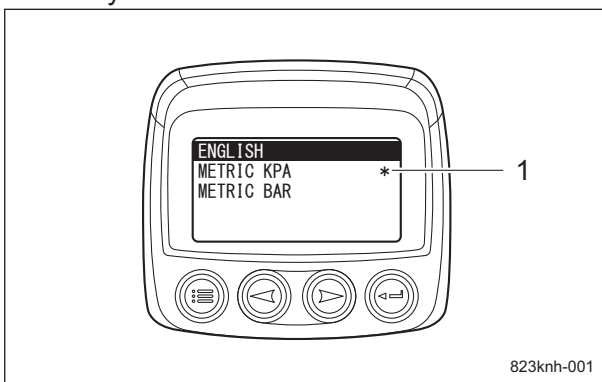

Select Units_001

1	Asterisk
---	----------

No.	Monitor display S	Units		
		ENGLISH	METRIC KPA	METRIC BAR
1	ENG RPM	RPM	RPM	RPM
2	ENG TORQ	%	%	%
3	LOAD@RPM	%	%	%
4	ACCEL1	%	%	%
5	DES ENG SP	RPM	RPM	RPM
6	COOL TEMP	F	C	C
7	THROTTLE	G/HR	L/HR	L/HR
8	BAT VOLT	VDC	VDC	VDC
9	BARO PRES	PSI	kPa	BAR
10	ENG HRS	H	H	H
11	OIL PRES	PSI	kPa	BAR
12	DOC TEMP	F	C	C
13	EF IN T	F	C	C
14	DIFF PRES	PSI	kPa	BAR
15	EF OUT T	F	C	C
16	PT LAMP	-	-	-
17	DPF ST	-	-	-
18	DPF AR ST	-	-	-
19	INHIBIT ST	-	-	-
20	DPF INHIB SW	-	-	-
21	EXH T LAMP	-	-	-
22	MACH HRS	H	H	H
23	FUEL LEVEL	%	%	%
24	BAT VOLT	VDC	VDC	VDC

Note:

The factory default unit is "METRIC KPA".

Handling Instructions

Adjust Backlight

With "ADJUST BACKLIGHT", the brightness of the monitor display can be adjusted. Press the right arrow key to make the display brighter. Press the left arrow key to make the display darker.

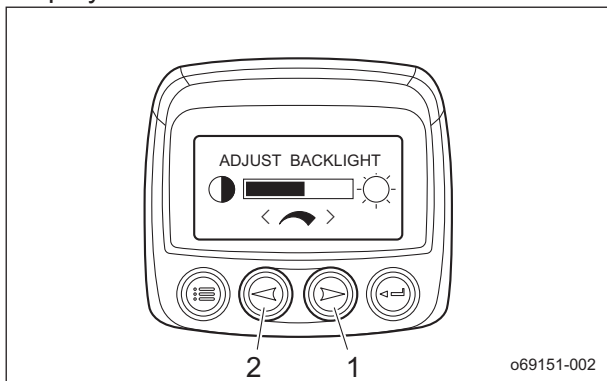

Adjust Backlight_001

1	Right arrow key
2	Left arrow key

Adjust Contrast

With "ADJUST CONTRAST", the contrast of the monitor display can be adjusted. Press the right arrow key to decrease the contrast. Press the left arrow key to increase the contrast.

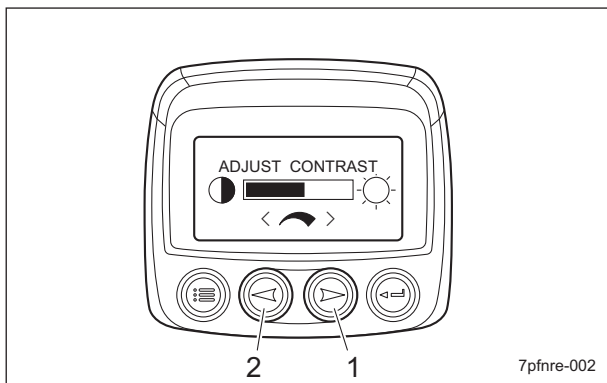

Adjust Contrast_001

1	Right arrow key
2	Left arrow key

Utilities

With "UTILITIES", the remaining fuel volume can be specified and the monitor configuration can be displayed.

The following 6 items appear when "UTILITIES" is selected.

- GAGE DATA
- REMOVE ALL GAGES
- SOFTWARE VERSION
- FAULT CONVERSION
- ANALOG INPUT
- OEM

Note:

"GAGE DATA" and "REMOVE ALL GAGES" are not supported on this machine.

■ Software Version

With "SOFTWARE VERSION", the software version of the monitor can be displayed.

■ Fault Conversion

With "FAULT CONVERSION", the J1939 fault code conversion method can be specified.

The monitor normally detects J1939 version 4.

Since the engine ECU of this machine uses J1939 version 4, no adjustments are necessary.

Handling Instructions

■Analog Input

With "ANALOG INPUT", remaining fuel volume information can be specified. The following 2 items appear when "ANALOG INPUT" is selected.

- BACKLIGHT DIMMER
- FUEL LEVEL

Important

"BACKLIGHT DIMMER" is not supported on this machine. Always select "FUEL LEVEL". If "BACKLIGHT DIMMER" is selected, "NO DATA" appears as the value for the fuel level parameter.

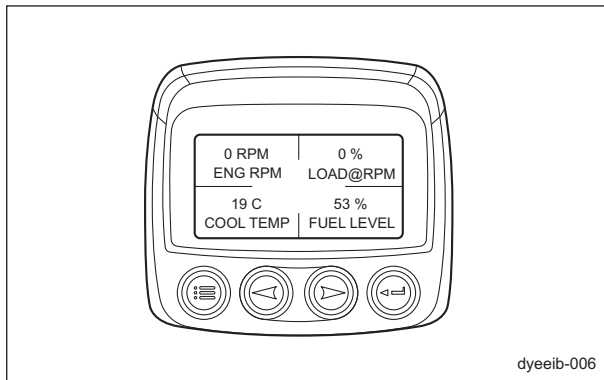

Analog Input_001

Note:
The factory default analog input is "FUEL LEVEL".

1. Fuel Level

With "FUEL LEVEL", the low fuel level can be specified.

1. Press the menu key.
After the main menu appears, use the arrow keys to highlight "UTILITIES", and then press the Enter key.

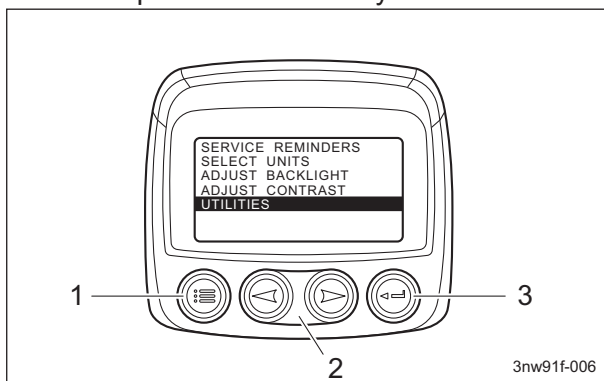

Fuel Level_001

1	Menu key
2	Arrow keys
3	Enter key

2. Highlight "ANALOG INPUT", and then press the Enter key.

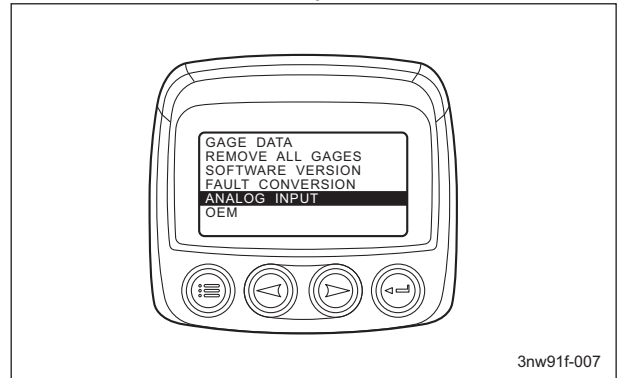

Fuel Level_002

3. Highlight "FUEL LEVEL", and then press the Enter key.

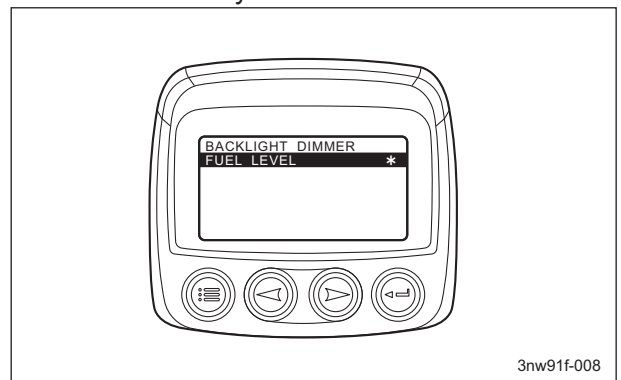

Fuel Level_003

4. Highlight "SET LOW FUEL LEVEL", and then press the Enter key.

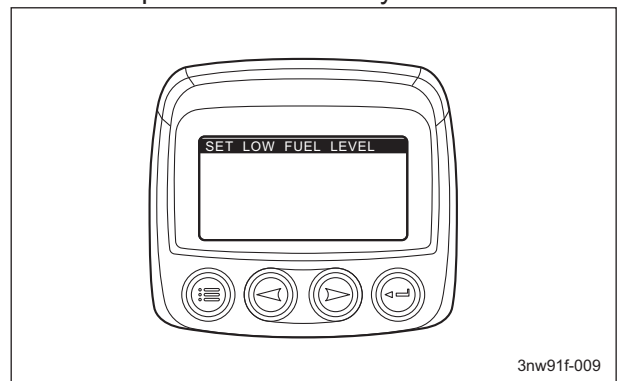

Fuel Level_004

Handling Instructions

5. "LOW FUEL" appears.

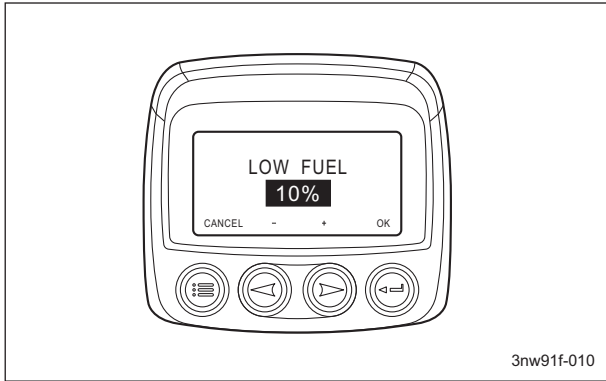

Fuel Level_005

6. Press the right arrow key to increase the value. Press the left arrow key to decrease the value. The value can be set between 10% and 80% in 5% increments.
7. To save the specified value, press the Enter key.

Note:

The factory default low fuel level is 10%.

2. Low Fuel Level Display

Caution

If a warning message appears, stop operation, and then supply fuel.

1. When the fuel level falls below the specified low fuel level, a warning message appears in the monitor display and the LED (yellow) lights up. The warning message appears on two pages. Use the arrow keys to change the page.
 - Text 1

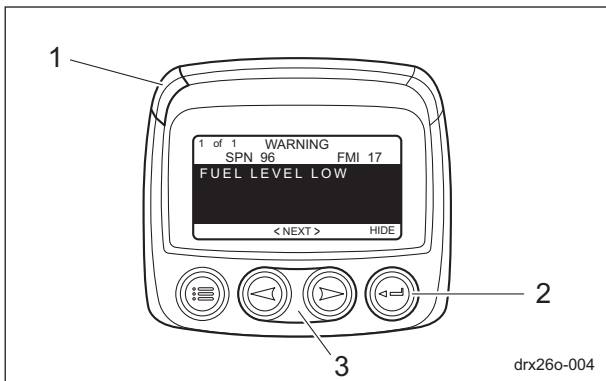

Low Fuel Level Display_001

1	LED (yellow)
2	Enter key
3	Arrow keys

• Text 2



Low Fuel Level Display_002

2. Pressing the Enter key changes the screen from the warning message to the parameter display.
3. A warning mark appears in the upper-right corner of the monitor display.

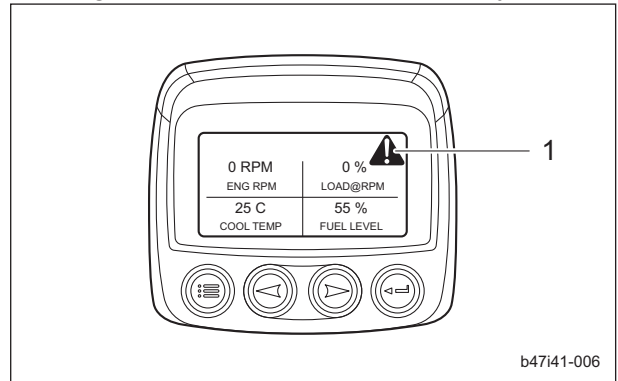

Low Fuel Level Display_003

1	Warning mark
---	--------------

4. When fuel is supplied to bring the fuel level above the specified low fuel level, the warning message and mark disappear.

■ OEM

"OEM" is used when the manufacturer specifies factory default settings.

Important

No adjustments by the operator are necessary.

Handling Instructions

Fault Code Displays

Important

When the fault code (DTC) appears in the monitor display, contact your dealer.

A fault code (DTC) appears in the monitor display when a failure occurs on the function of engine.

Each fault code is displayed over two pages. Use the arrow keys to change the page.

- Text 1
The fault code name appears.

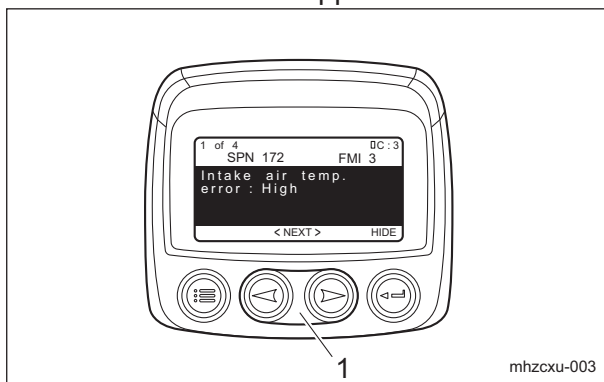

Fault Code Displays_001

1	Arrow keys
---	------------

- Text 2
The corrective action appears.

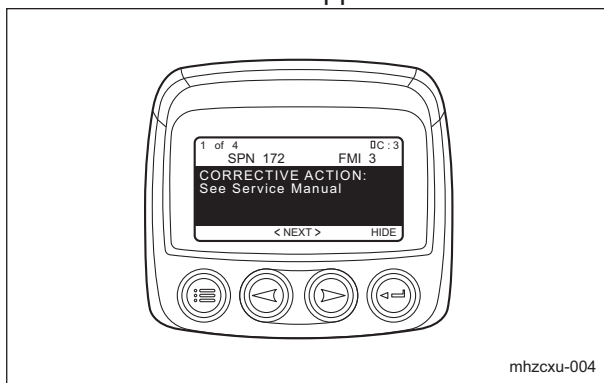

Fault Code Displays_002

Pressing the Enter key changes the screen from the fault code to the parameter display.

Important

If the service reminders are configured, the warning message of the replacement time period for consumables and the fault code may appear all together.

If "ACTIVE FAULTS - ECU" message appears, check both the service reminder warning message and the fault code message.

To check the service reminder warning message:

Highlight the service reminder warning message, and then press the Enter key.

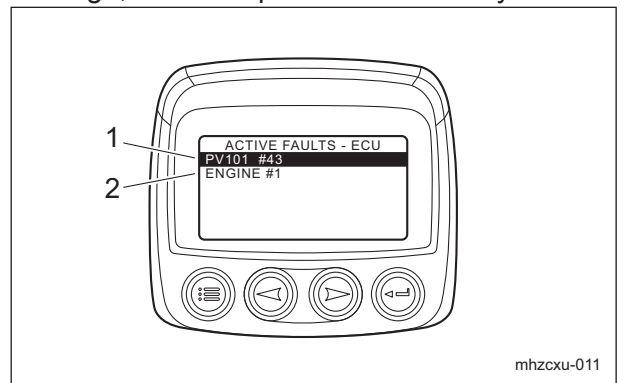

Fault Code Displays_003

1	Service reminder warning message
2	Fault code

- Text 1
The item of requiring replacement of consumables appears.

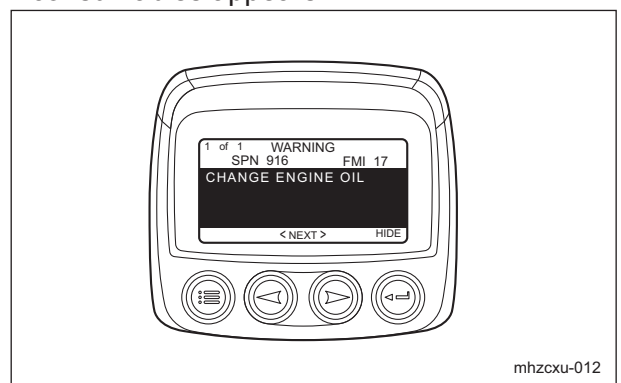

Fault Code Displays_004

Handling Instructions

- Text 2
The corrective action appears.



Fault Code Displays_005

- Text 2
The corrective action appears.



Fault Code Displays_008

To check the fault code (DTC):
Highlight the fault code message, and then press the Enter key.

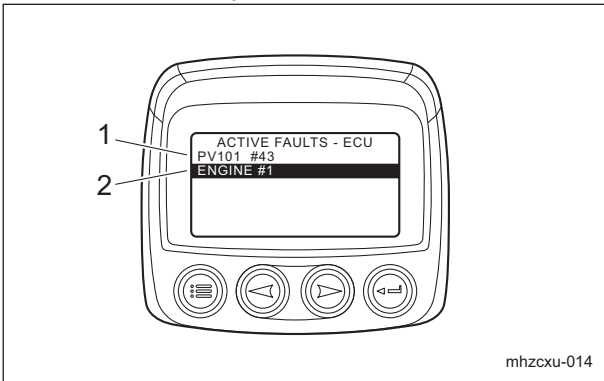

Fault Code Displays_006

1	Service reminder warning message
2	Fault code

- Text 1
The fault code name appears.

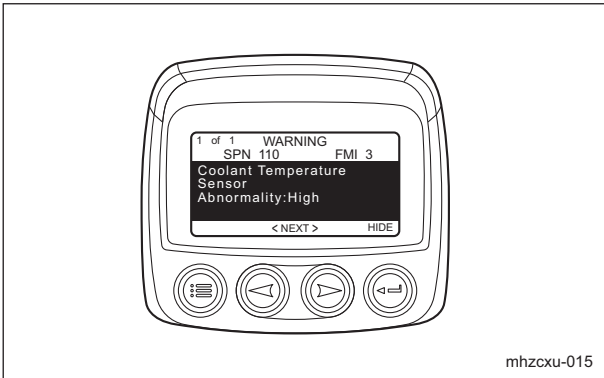

Fault Code Displays_007

Note:

The warning mark continues to be displayed in the upper right corner of the monitor display if the warning message of service reminder ignored and the Enter key pressed to hide the message.

Press the menu key to return to the message display of "ACTIVE FAULTS - ECU", and then check the warning message and the fault code.

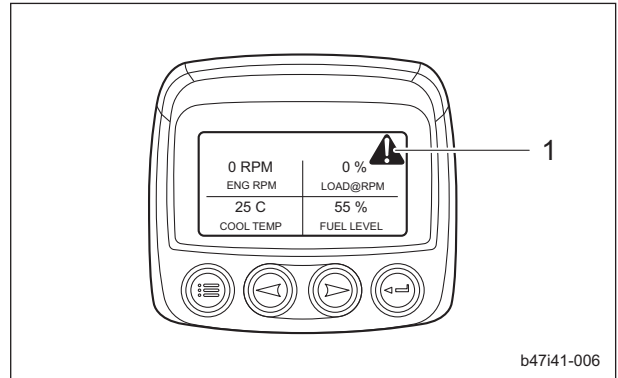

Fault Code Displays_009

1	Warning mark
---	--------------

Handling Instructions

List of Fault Codes

Important

When the fault code appears in the monitor display, refer to "Kubota DIAGNOSIS MANUAL COMMON RAIL SYSTEM" or contact your dealer.

The fault codes (DTC) and corresponding information that appear in the monitor display are listed below.

No.	DTC name Text 1	Corrective action Text 2	ISO 14229 P-Code	J1939-73		Detection item	Limp Home Action by engine ECU (system action)	Behavior During Malfunction	Recovery from error
				SPN	FMI				
8	Coolant temperature sensor: Low	See Service Manual	P0117	110	4	Ground short circuit of sensor or harness	During start-up = -25 degC (-13 degF) [default value] Under other conditions = 80 degC (176 degF) [default value] Output limitation: Approximately 75% of normal condition EGR stop Intake throttle full open	- White smoke increases at low temperature - Insufficient output - Worsening exhaust gas emissions	Key switch turn OFF
9	Coolant temperature sensor: High	See Service Manual	P0118	110	3	Open circuit or +B short circuit of sensor or harness	During start-up = -25 degC (-13 degF) [default value] Under other conditions = 80 degC (176 degF) [default value] Output limitation: Approximately 75% of normal condition EGR stop Intake throttle full open	- White smoke increases at low temperature - Insufficient output - Worsening exhaust gas emissions	Key switch turn OFF
17	Engine overheat	Stop mowing!!	P0217	110	0	Overheat of engine coolant temperature	Output limitation: Approximately 75% of normal condition EGR stop Intake throttle full open	- Insufficient output - Overheat	Diagnostic counter = zero
18	Engine overrun	See Service Manual	P0219	190	0	Engine speed exceeds threshold speed	Stop injection (Q = 0 mm ³ /st)	- Overrun	Diagnostic counter = zero
21	No input of NE sensor (Crank position sensor) pulse	See Service Manual	P0335	636	8	Open circuit or short circuit of sensor or harness Failure of sensor	Output limitation: Approximately 75% of normal condition	(Running only with G signal) - Faulty starting - Engine Vibration increases slightly - Insufficient output	Key switch turn OFF

Handling Instructions

No.	DTC name Text 1	Corrective action Text 2	ISO 14229 P-Code	J1939-73		Detection item	Limp Home Action by engine ECU (system action)	Behavior During Malfunction	Recovery from error
				SPN	FMI				
26	+B short of glow relay driving circuit	See Service Manual	P0380	52354 4	3	+B short of glow relay driving circuit	None	(At low temperature) - Faulty starting - White smoke increases	Key switch turn OFF
27	Ground short of glow relay driving circuit	See Service Manual	P0380	52354 4	4	Ground short of glow relay driving circuit	None	(At low temperature) - Faulty starting - White smoke increases	Key switch turn OFF
29	Oil pressure error	Stop ENG See Service Manual	P0524	100	1	Oil pressure switch	None	- Engine stops	Key switch turn OFF
30	Battery voltage: Low	See Service Manual	P0562	168	4	Open circuit, short circuit or damage of harness Failure of battery	Output limitation: Approximately 75% of normal condition EGR stop Intake throttle full open	- Faulty starting - Insufficient output - Worsening exhaust gas emissions - Engine stops in some cases	Diagnostic counter = zero
31	Battery voltage: High	See Service Manual	P0563	168	3	Open circuit, short circuit or damage of harness Failure of battery	Output limitation: Approximately 75% of normal condition EGR stop Intake throttle full open	- Faulty starting - Insufficient output - Worsening exhaust gas emissions	Key switch turn OFF
34	ECU FLASH ROM error	Stop ENG See Service Manual	P0605	628	2	FLASH ROM error	Engine stop	- Engine stops	Key switch turn OFF
35	ECU CPU (Main IC) error	Stop ENG See Service Manual	P0606	1077	2	Failure of CPU and/or IC	Engine stop	- Engine stops	Key switch turn OFF
43	Sensor supply voltage 1: Low	See Service Manual	P0642	3509	4	Sensor supply voltage 1 error or recognition error	Forced Idle (Accelerator = 0%) EGR stop Intake throttle full open	- Faulty starting - Insufficient output - Worsening exhaust gas emissions - Engine stops in some cases	Key switch turn OFF
51	Accelerator position sensor 1: Low	See Service Manual	P2122	91	4	Ground short circuit or open circuit of sensor or harness	Forced Idle (Accelerator = 0%)	- Insufficient output	Diagnostic counter = zero
52	Accelerator position sensor 1: High	See Service Manual	P2123	91	3	Battery short circuit out of sensor or harness	Forced Idle (Accelerator = 0%)	- Insufficient output	Diagnostic counter = zero

Handling Instructions

No.	DTC name Text 1	Corrective action Text 2	ISO 14229 P-Code	J1939-73		Detection item	Limp Home Action by engine ECU (system action)	Behavior During Malfunction	Recovery from error
				SPN	FMI				
53	Accelerator position sensor 2: Low	See Service Manual	P2127	29	4	Ground short circuit or open circuit of sensor or harness	Forced Idle (Accelerator = 0%)	- Insufficient output	Diagnostic counter = zero
54	Accelerator position sensor 2: High	See Service Manual	P2128	29	3	Battery short circuit out of sensor or harness	Forced Idle (Accelerator = 0%)	- Insufficient output	Diagnostic counter = zero
60	Barometric pressure sensor error (Low side)	See Service Manual	P2228	108	4	Sensor or ECU internal circuit short to ground	65kPa (0.663 kgf/cm ² , 9.43 psi) [default value]	- Insufficient output	Diagnostic counter = zero
61	Barometric pressure sensor error (High side)	See Service Manual	P2229	108	3	Sensor or ECU internal circuit short to +B	65kPa (0.663 kgf/cm ² , 9.43 psi) [default value]	- Insufficient output	Diagnostic counter = zero
64	CAN2 Bus off	See Service Manual	U0075	52354 7	2	CAN2 +B or GND short circuit or high traffic error	Forced Idle (Accelerator = 0%)	- Insufficient output - Transmitted CAN data are invalid	Key switch turn OFF
65	CAN-KBT Frame error	See Service Manual	U0081	52354 8	2	CAN-KBT original frame open circuit error	Forced Idle (Accelerator = 0%)	- Insufficient output	Key switch turn OFF
74	Exhaust gas temperature sensor 1: Low	See Service Manual	P0543	3242	4	Ground short circuit of sensor or harness	0 degC (32 degC) [default value] Output limitation: Approximately 75% of normal condition	None	Key switch turn OFF
75	Exhaust gas temperature sensor 1: High	See Service Manual	P0544	3242	3	Open circuit or +B short circuit of sensor or harness	0 degC (32 degF) [default value] Output limitation: Approximately 75% of normal condition	None	Key switch turn OFF
76	Exhaust gas temperature sensor 0: Low	See Service Manual	P0546	4765	4	Ground short circuit of sensor or harness	0 degC (32 degF) [default value] Output limitation: Approximately 75% of normal condition	None	Key switch turn OFF
77	Exhaust gas temperature sensor 0: High	See Service Manual	P0547	4765	3	Open circuit or +B short circuit of sensor or harness	0 degC (32 degF) [default value] Output limitation: Approximately 75% of normal condition	None	Key switch turn OFF
78	EEPROM check sum error	See Service Manual	P1990	52370 0	13	KBT-EEPROM check sum error	None	None	Key switch turn OFF
86	Exhaust gas temperature sensor 2: Low	See Service Manual	P242C	3246	4	Ground short circuit of sensor or harness	0 degC (32 degF) [default value] Output limitation: Approximately 75% of normal condition	None	Key switch turn OFF

Handling Instructions

No.	DTC name Text 1	Corrective action Text 2	ISO 14229 P-Code	J1939-73		Detection item	Limp Home Action by engine ECU (system action)	Behavior During Malfunction	Recovery from error
				SPN	FMI				
87	Exhaust gas temperature sensor 2: High	See Service Manual	P242D	3246	3	Open circuit or +B short circuit of sensor or harness	0 degC (32 degF) [default value] Output limitation: Approximately 75% of normal condition	None	Key switch turn OFF
88	Differential pressure sensor 1: Low	See Service Manual	P2454	3251	4	Ground short circuit of sensor or harness	0 kPa (0.0 kgf/cm ² , 0.0 psi) [default value] Output limitation: Approximately 75% of normal condition	None	Key switch turn OFF
89	Differential pressure sensor 1: High	See Service Manual	P2455	3251	3	Open circuit or +B short circuit of sensor or harness	0 kPa (0.0 kgf/cm ² , 0.0 psi) [default value] Output limitation: Approximately 75% of normal condition	None	Key switch turn OFF
93	Emergency Exhaust gas temperature sensor 0: High	Stop ENG See Service Manual	P3002	4765	0	DOC inlet temp. (T0): High	Stop injection (Q = 0 mm ³ /st) Engine stop Inhibit starter relay activation until exhaust temp. reduces down to 300 degC (572 degF)	- Engine stops - Inhibited cranking until down to 300 degC (572 degF)	- Engine stops - Inhibited cranking until down to 300 degC (572 degF)
94	Emergency Exhaust gas temperature sensor 1: High	Stop ENG See Service Manual	P3003	3242	0	DPF inlet temp. (T1): High	Stop injection (Q = 0 mm ³ /st) Engine stop Inhibit starter relay activation until exhaust temp. reduces down to 300 degC (572 degF)	- Engine stops - Inhibited cranking until down to 300 degC (572 degF)	Under 300 degC & Key switch turn OFF
95	Emergency Exhaust gas temperature sensor 2: High	Stop ENG See Service Manual	P3004	3246	0	DPF outlet temp. (T2): High	Stop injection (Q = 0 mm ³ /st) Engine stop EGR stop Intake throttle 0% open (Close) Inhibit starter relay activation until exhaust temp. reduces down to 300 degC (572 degF)	- Engine stops - Inhibited cranking until down to 300 degC (572 degF)	Under 300 degC & Key switch turn OFF
96	Excessive PM3	Start DPF Parked Regeneration immediately	P3006	3701	15	PM accumulation level 3	Output limitation: Approximately 50% of normal condition	- Insufficient output	Diagnostic counter = zero

Handling Instructions

No.	DTC name Text 1	Corrective action Text 2	ISO 14229 P-Code	J1939-73		Detection item	Limp Home Action by engine ECU (system action)	Behavior During Malfunction	Recovery from error
				SPN	FMI				
97	Excessive PM4	Stop engine!! Contact dealer immediately	P3007	3701	16	PM accumulation level 4	Output limitation: Approximately 50% of normal condition	- Insufficient output	Diagnostic counter = zero
98	Excessive PM5	Stop engine!! Contact dealer immediately	P3008	3701	0	PM accumulation level 5	Output limitation: Approximately 50% of normal condition	- Insufficient output	Key switch turn OFF (Reset by Service tool)
101	Parked regeneration time out	See Service Manual	P3013	52359 0	16	Time out error: regeneration incomplete due to low temperature of DPF	None	None	Diagnostic counter = zero (Leaving from Parked active regeneration status)
102	All exhaust temp. sensor failure	See Service Manual	P3018	52359 9	0	All exhaust temp. sensor failure simultaneously	Output limitation: Approximately 75% of normal condition	None	Diagnostic counter = zero
103	High exhaust gas temp. after emergency high temp. DTC	Stop ENG See Service Manual	P3023	52360 1	0	Exhaust gas temperature sensor 0, 1, 2 output	Engine stop Inhibit starter relay activation until all exhaust temp. (T0, T1, T2) reduces down to 300 degC (572 degF)	None	Diagnostic counter = zero
104	High frequency of regeneration	See Service Manual	P3024	52360 2	0	Time interval from the end time to the start time of the regeneration	Output limitation: Approximately 50% of normal condition EGR stop	- Worsening exhaust gas emissions (NOx)	Key switch turn OFF (Reset by Service tool)
107	CAN CCVS (Parking SW and Vehicle speed) frame error	See Service Manual	U0082	52359 1	2	CAN_CCVS communication stopping	Parking SW = OFF, Vehicle speed = 0 [default value]	None	Key switch turn OFF
108	CAN CM1 (Regen SW) frame error	See Service Manual	U0083	52359 2	2	CAN_CM1 communication stopping	Regeneration inhibit = ON, Parked regeneration SW = OFF [default value]	None	Key switch turn OFF
111	CAN ETC5 (Neutral SW) frame error	See Service Manual	U0086	52359 5	2	CAN_ETC5 communication stopping	Neutral SW = OFF [default value]	None	Key switch turn OFF
114	FUEL LEVEL LOW	Refuel	None	96	17	Remaining fuel volume at specified value or less (factory	None	None	Supply fuel until remaining fuel volume reaches the specified

Handling Instructions

No.	DTC name Text 1	Corrective action Text 2	ISO 14229 P-Code	J1939-73		Detection item	Limp Home Action by engine ECU (system action)	Behavior During Malfunction	Recovery from error
				SPN	FMI				
114	FUEL LEVEL LOW	Refuel	None	96	17	default setting=10%) Can be adjusted between 10% and 80%	None	None	value or above
115				916	17				
116	Open circuit of electric governor solenoid	See Service Manual	P1830	52377 1	5	· Open circuit of solenoid / harness.	· Engine stop · DPF active regeneration is inhibited	· Engine stall	· Key switch turn OFF
117	Electric governor solenoid circuit short to GND / B+	See Service Manual	P1831	52377 1	5	· GND short circuit of solenoid / harness.	· Engine stop · DPF active regeneration is inhibited	· Engine stall	· Key switch turn OFF
118	Feed pump circuit open / short to B+	See Service Manual	P1840	52376 1	3	· Open circuit or B+ short circuit of pump / harness.	None	· Insufficient output or Engine stall	· Key switch turn OFF
119	Feed pump circuit short to GND	See Service Manual	P1841	52376 1	4	· GND short circuit of pump / harness.	None	· Insufficient output or Engine stall	· Key switch turn OFF
120	Reformer temperature high abnormally	See Service Manual	P1834	52375 3	0	· Abnormally high reformer temperature	· DPF active regeneration is inhibited	None	· Key switch turn OFF
121	Blower pressure abnormal	See Service Manual	P1835	52375 1	0	· Abnormally high blower pressure	· DPF active regeneration is inhibited	None	· Key switch turn OFF
122	Blower pressure sensor: High	See Service Manual	P1818	52376 4	3	· Open circuit or +B short circuit of sensor / harness.	[Default value] 0 kPa (0 psi) · DPF active regeneration is inhibited	None	· Key switch turn OFF
123	Blower pressure sensor: Low	See Service Manual	P1819	52376 4	4	· GND short circuit of sensor / harness.	[Default value] 0 kPa (0 psi) · DPF active regeneration is inhibited	None	· Key switch turn OFF
124	Reformer temperature sensor: High	See Service Manual	P1832	52376 3	3	· Open circuit or +B short circuit of sensor / harness.	[Default value] 0 °C (32 °F) · DPF active regeneration is inhibited	None	· Key switch turn OFF

Handling Instructions

No.	DTC name Text 1	Corrective action Text 2	ISO 14229 P-Code	J1939-73		Detection item	Limp Home Action by engine ECU (system action)	Behavior During Malfunction	Recovery from error
				SPN	FMI				
125	Reformer temperature sensor: Low	See Service Manual	P1833	52376 3	4	· GND short circuit of sensor / harness.	[Default value] 0 °C (32 °F) · DPF active regeneration is inhibited	None	· Key switch turn OFF
126	Burner temperature sensor: High	See Service Manual	P1815	52376 2	3	· Open circuit or +B short circuit of sensor / harness.	[Default value] 0 °C (32 °F) · DPF active regeneration is inhibited	None	· Key switch turn OFF
127	Burner temperature sensor: Low	See Service Manual	P1816	52376 2	4	· GND short circuit of sensor / harness.	[Default value] 0 °C (32 °F) · DPF active regeneration is inhibited	None	· Key switch turn OFF
128	Blower motor (Main circuit) malfunction	See Service Manual	P1806	52376 8	5	· Open circuit or +B short circuit of harness. · Blower motor malfunction	· DPF active regeneration is inhibited	None	· Key switch turn OFF
129	Blower motor (Sub circuit) malfunction	See Service Manual	P1807	52376 8	5	· Open circuit or +B short circuit of harness. · Air-blow malfunction. · Sub blower motor circuit malfunction.	· DPF active regeneration is inhibited	None	· Key switch turn OFF
130	Circuit of solenoid valve 1 for fuel reformer open	See Service Manual	P1808	52377 0	5	· Open circuit of solenoid valve 1 / harness.	· DPF active regeneration is inhibited	None	· Key switch turn OFF
131	Circuit of solenoid valve 1 for fuel reformer short to GND	See Service Manual	P1809	52377 0	4	· GND short circuit of harness.	· DPF active regeneration is inhibited	None	· Key switch turn OFF
132	Circuit of solenoid valve 1 for fuel reformer short to B+	See Service Manual	P1810	52377 0	3	· B+ short circuit of harness.	· DPF active regeneration is inhibited	None	· Key switch turn OFF
133	Circuit of solenoid valve 2 for fuel reformer open	See Service Manual	P1811	52376 9	5	· Open circuit of solenoid valve 2 / harness.	· DPF active regeneration is inhibited	None	· Key switch turn OFF
134	Circuit of solenoid valve 2 for fuel	See Service Manual	P1812	52376 9	4	· GND short circuit of harness.	· DPF active regeneration is inhibited	None	· Key switch turn OFF

Handling Instructions

No.	DTC name Text 1	Corrective action Text 2	ISO 14229 P-Code	J1939-73		Detection item	Limp Home Action by engine ECU (system action)	Behavior During Malfunction	Recovery from error
				SPN	FMI				
134	reformer short to GND	See Service Manual	P1812	52376 9	4	· GND short circuit of harness.	· DPF active regeneration is inhibited	None	· Key switch turn OFF
135	Circuit of solenoid valve 2 for fuel reformer short to B+	See Service Manual	P1813	52376 9	3	· B+ short circuit of harness.	· DPF active regeneration is inhibited	None	· Key switch turn OFF
136	Circuit of fuel pump for fuel reformer open	See Service Manual	P1803	52376 7	5	· Open circuit of fuel pump / harness.	· DPF active regeneration is inhibited	None	· Key switch turn OFF
137	Circuit of fuel pump for fuel reformer short to GND	See Service Manual	P1804	52376 7	4	· GND short circuit of harness.	· DPF active regeneration is inhibited	None	· Key switch turn OFF
138	Circuit of fuel pump for fuel reformer short to B+	See Service Manual	P1805	52376 7	3	· B+ short circuit of harness.	· DPF active regeneration is inhibited	None	· Key switch turn OFF
139	Over current in circuit of burner glow	See Service Manual	P1801	52376 6	6	· Over current in circuit of glow	· DPF active regeneration is inhibited	None	· Key switch turn OFF
140	Circuit of burner glow open / short to B+	See Service Manual	P1802	52376 6	5	· Open circuit or short circuit of harness	· DPF active regeneration is inhibited	None	· Key switch turn OFF
141	Circuit of glow relay for fuel reforming open / short to B+	See Service Manual	P1836	52376 5	3	· Open circuit or B+ short circuit of relay / harness	· DPF active regeneration is inhibited	None	· Key switch turn OFF
142	Circuit of glow relay for fuel reforming short to GND	See Service Manual	P1837	52376 5	4	· GND short circuit of relay / harness	· DPF active regeneration is inhibited	None	· Key switch turn OFF
143	Reformer abnormal	See Service Manual	P1844	52375 5	2	· Reformer is not working when DPF regeneration is active.	· DPF active regeneration is inhibited	None	· Key switch turn OFF
144	Fail to rise DPF temperature	See Service Manual	P1845	52375 6	2	· DPF temperature rising control is incomplete when DPF regeneration is active.	· DPF active regeneration is inhibited	None	· Key switch turn OFF

Handling Instructions

No.	DTC name Text 1	Corrective action Text 2	ISO 14229 P-Code	J1939-73		Detection item	Limp Home Action by engine ECU (system action)	Behavior During Malfunction	Recovery from error
				SPN	FMI				
145	Over current in circuit of blower motor	See Service Manual	P1846	52376 8	6	<ul style="list-style-type: none"> Over current in circuit of blower motor for fuel reforming 	<ul style="list-style-type: none"> DPF active regeneration is inhibited 	None	<ul style="list-style-type: none"> Key switch turn OFF
146	Fail to ignite burner	See Service Manual	P1848	52375 7	2	<ul style="list-style-type: none"> Fail to ignite burner (Solenoid valve 2 or ignition glow is not working.) 	<ul style="list-style-type: none"> DPF active regeneration is inhibited 	None	<ul style="list-style-type: none"> Key switch turn OFF
147	Low coolant temp. for DPF regeneration	See Service Manual	P1849	52375 0	2	<ul style="list-style-type: none"> Fail to warm-up coolant temp. for DPF regeneration 	<ul style="list-style-type: none"> DPF active regeneration is inhibited 	None	<ul style="list-style-type: none"> Diag counter = zero
148	EEP write error	See Service Manual	P1850	52374 9	2	<ul style="list-style-type: none"> Write failure to EEPROM 	<ul style="list-style-type: none"> Forced Idle (Accelerator=0%) 	<ul style="list-style-type: none"> Insufficient output 	<ul style="list-style-type: none"> Key switch turn OFF
149	Excessive power consumption during regeneration	See Service Manual	P1851	52374 8	2	<ul style="list-style-type: none"> Excessive power consumption during DPF regeneration 	<ul style="list-style-type: none"> Suspension of Regeneration 	None	<ul style="list-style-type: none"> DPF regeneration is successful completion
150	Rack position sensor: High	See Service Manual	P1827	52377 3	3	<ul style="list-style-type: none"> Open circuit or B+ short circuit of sensor / harness 	<ul style="list-style-type: none"> Engine stop 	<ul style="list-style-type: none"> Engine stall 	<ul style="list-style-type: none"> Key switch turn OFF
151	Rack position sensor: Low	See Service Manual	P1828	52377 3	4	<ul style="list-style-type: none"> GND short circuit of sensor / harness. Mount condition of sensor is incorrect. 	<ul style="list-style-type: none"> Engine stop 	<ul style="list-style-type: none"> Engine stall 	<ul style="list-style-type: none"> Key switch turn OFF

Handling Instructions

Handling Instructions

Travel of Machine

Traveling Procedure

⚠ Caution

Under any circumstances drive the machine at such a speed that you can stop it immediately for emergencies.

⚠ Caution

When traveling, be sure to push the reel rotation switch to the "Stop" side and raise the mower units.

1. Start the engine.
2. Raise all mower units.
3. Firmly depress the brake pedal to release the locking pedal and release the brake pedal.
4. Slowly depress the traveling pedal.
5. The machine starts traveling.

Towing The Machine

If the machine does not travel due to engine trouble, etc., you can move it in the following ways:

⚠ Caution

Do not touch the unload valve except when towing the machine.

⚠ Caution

Before starting the engine, be sure to close the unload valves.

Important

When towing the machine, travel at a speed no more than 3.0 km/h.

In addition, do not tow the machine for more than 3 minutes.

If the towing speed is too fast or there is excessive movement, the pump or motor will be damaged.

Important

Do not loosen the unload valve three turns or more.

1. Stop the engine.
"Procedure to Stop Engine" (Page 4-23)
2. Depress the locking pedal while firmly depressing the brake pedal to lock it.
3. Chock the wheels.
4. Secure the rope to the tow hook.

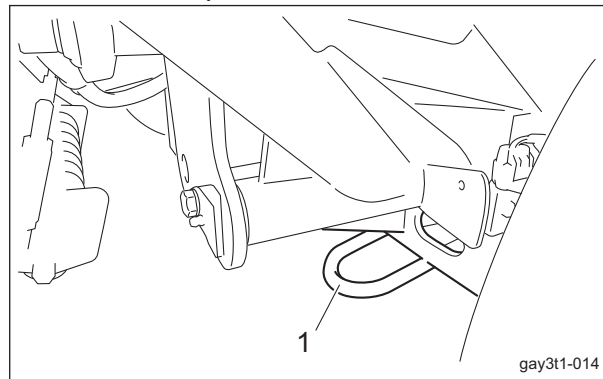

Towing The Machine_001

1	Tow hook
---	----------

5. Open the underseat cover.
"Underseat Cover" (Page 4-39)
6. Turn the unload valve under the seat 1 to 1.5 turns counterclockwise.

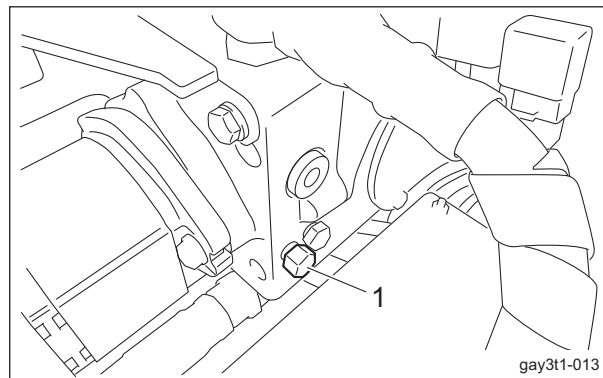

Towing The Machine_002

1	Unload valve
---	--------------

7. Close the underseat cover.
8. Remove the wheel stoppers.
9. Firmly depress the brake pedal to release the locking pedal.

⚠ Warning

While towing, always keep your foot on the brake pedal and depress the brake pedal at any time to stop.

10. Tow the machine slowly.

Handling Instructions

Cutting Work

Cutting Work

Warning

Do not start to move or stop the machine abruptly.
To do so is very dangerous. In addition, it may damage the hydraulic system or result in oil leakage.

Caution

Be sure to operate at an appropriate speed for the mowing site.
When cutting over bumpy surfaces, keep the engine rpm steady, and slow down the cutting speed.

Caution

Note that if you stop operating the mower unit up/down lever before the mower units are raised completely, reel rotation may not stop. Reel rotation will be turned on or off based on the sensor-detected position of the mower units.

Caution

After sand topdressing, close the cutter cover. Otherwise, sand may fly out and get in your eyes.

Important

Mow with the lever shifted to the "Down" position.
When the lever is returned to the neutral position, the cylinders are fixed, preventing mowing on undulations.

1. Release the mower lock levers (latches) for mower units #4 and #5.
2. Start the engine.
3. Raise all mower units.
4. Firmly depress the brake pedal to release the locking pedal for releasing the locked brake pedal.
5. Shift the throttle knob to rev the engine up to the maximum rpm.

6. Set the traveling/working selector switch to the "Working" position.
7. Shift the mower unit up/down lever to the "Down" position to lower the mower units.
8. Set the reel rotation switch to the "Rotation" position to rotate the reel cutters (cutting cylinders) of all mower units.
9. Depress the traveling pedal to start cutting work.

Note:

During the work, the reel cutters (cutting cylinders) will rotate or stop in sync with the up and down motion of the mower units.

Removal/Installation of Grass Catcher

Caution

Stop the engine before removing or installing the grass catcher.

1. Set the reel rotation switch to the "Stop" position.
2. Lower the mower units.
3. Apply the parking brake.
4. Stop the engine.
5. Remove or install the grass catcher.
 - Removal of grass catcher:
Lift up the grass catcher, and remove the mounting pins on the left and right sides of the grass catcher from the grass catcher mounting brackets.
 - Installation of grass catcher:
Install the mounting pins on the left and right sides of the grass catcher into the grass catcher mounting brackets.

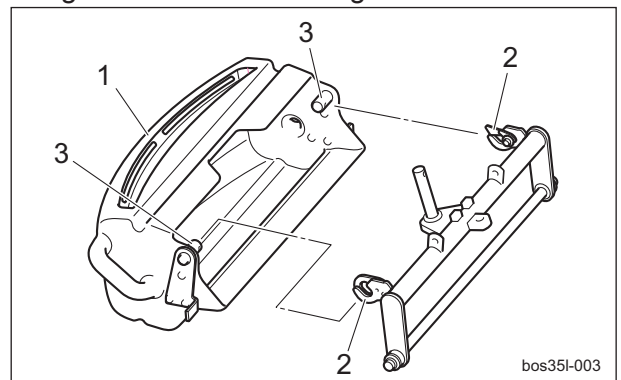

Removal/Installation of Grass Catcher_001

1	Grass catcher
2	Grass catcher mounting bracket
3	Mounting pin

Handling Instructions

Transporting

Transporting Procedure

When using a truck or trailer for transporting, drive the machine forward to load it and in reverse to unload it.

If the roof is installed on the machine, remove it.

Otherwise, the roof may be damaged by wind pressure.

Note:

When tying down the machine, secure the rope at the following locations.

At the front of the machine, use the tow hooks on the left and right of the front axle.

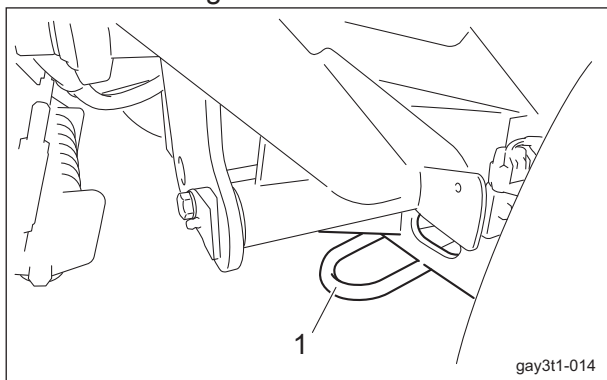

Transporting Procedure_001

1	Tow hook
---	----------

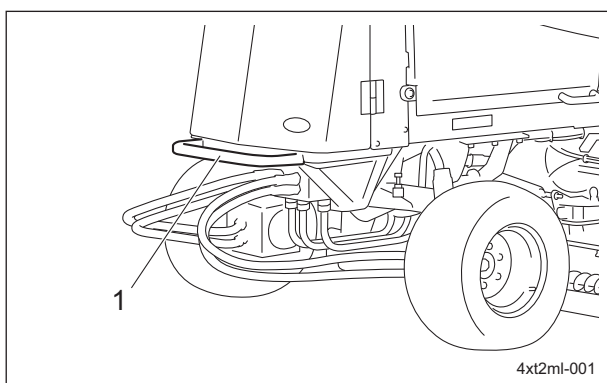

Transporting Procedure_002

1	Bumper
---	--------

Long-Term Storage

Before Long-Term Storage

- Remove dirt, grass clippings, debris, oil stains etc. completely.
- Supply oil and apply grease to appropriate parts.
- Remove the negative terminal of the battery.

Maintenance Precautions	Page 5-2	Replacement of Fuel Filter	Page 5-44
Maintenance Schedule	Page 5-2	Change of Fuse	Page 5-45
Adjusted Value	Page 5-7		
DPF	Page 5-8		
About DPF	Page 5-8		
DPF Regeneration	Page 5-8		
Replacement of DPF	Page 5-12		
Conditions for DPF Regeneration	Page 5-13		
Jacking Up The Machine	Page 5-18		
About Jacking Up The Machine	Page 5-18		
Jack-up Points	Page 5-18		
Greasing	Page 5-20		
About Greasing	Page 5-20		
Greasing Points	Page 5-20		
Lubrication	Page 5-24		
About Lubrication	Page 5-24		
Lubricating Points	Page 5-24		
Maintenance Work	Page 5-26		
Swiveling Mower Units #2 and #3	Page 5-26		
Removing/Installing Tires	Page 5-27		
Adjustment of Belt Tension	Page 5-28		
Adjustment of Parking Brake	Page 5-28		
Adjustment of Brake	Page 5-29		
Adjusting The Neutral Position of The Piston Pump	Page 5-30		
Adjustment of Control Arm	Page 5-31		
Adjustment of Stoppers	Page 5-31		
Adjustment of Mower Unit Leveling Spring	Page 5-32		
Adjustment of Positions of Mower Units #2 and #3	Page 5-33		
Adjustment of Mower Stopper	Page 5-34		
Change of Coolant	Page 5-38		
Change of Hydraulic Oil	Page 5-40		
Change of Hydraulic Oil Filter	Page 5-41		
Change of Air Cleaner	Page 5-43		
Change of Engine Oil	Page 5-43		
Change of Engine Oil Filter	Page 5-44		

Maintenance

Maintenance Precautions

⚠ Caution

First, learn well the maintenance operations you plan to perform.

Important

Use tools appropriate for each maintenance operation.

Important

For the safe and best performance of your machine, use Baroness genuine parts for replacement and accessories.
Please note that our product warranty may be void if you use non-genuine parts for replacement or accessories.

Maintenance Schedule

LM551A

Follow the maintenance schedule below.

○ . . . Inspect, adjust, supply, clean

● . . . Replace (first time)

△ . . . Replace

Maintenance Item		Before Work	After Work	Every Week	Every 50 hrs.	Every 100 hrs.	Every 200 hrs.	Every 250 hrs.	Every 400 hrs.	Every 500 hrs.	Every 800 hrs.	Every 1000 hrs.	Every 1500 hrs.	Every 3000 hrs.	Every month	Every year	Every 2 years	Every 4 years	When Required	Remarks
*3	Check engine oil level and contamination	○																		
*3	Check fuel level	○																		
*3	Check coolant level	○																		
*3	Check fan belt	○																		
	Check hydraulic oil level	○																		
	Check hydraulic hoses condition (Moving part)	○																		
	Check tire pressures and condition	○																		
	Check cover condition	○																		

Maintenance

Maintenance Item		Before Work	After Work	Every Week	Every 50 hrs.	Every 100 hrs.	Every 200 hrs.	Every 250 hrs.	Every 400 hrs.	Every 500 hrs.	Every 800 hrs.	Every 1000 hrs.	Every 1500 hrs.	Every 3000 hrs.	Every month	Every year	Every 2 years	Every 4 years	When Required	Remarks
	Check traveling pedal motion	<input type="radio"/>																		
	Check brake function	<input type="radio"/>																		
	Check brake wire	<input type="radio"/>																		
	Check brake pedal play	<input type="radio"/>																		
	Check oil or water leaks	<input type="radio"/>																		
	Check damaged parts	<input type="radio"/>																		
	Check tightening bolts and nuts	<input type="radio"/>																		
	Check light illumination	<input type="radio"/>																		
	Check monitor	<input type="radio"/>																		By starting the engine
	Check interlock system safety function	<input type="radio"/>																		By starting the engine
	Clean radiator screen		<input type="radio"/>																	
	Clean radiator core		<input type="radio"/>																	
	Clean oil cooler core		<input type="radio"/>																	
	Clean machine exterior		<input type="radio"/>																	
	Clean engine area		<input type="radio"/>																	
	Open air cleaner evacuator valve to remove dust		<input type="radio"/>	<input type="radio"/>																Open valve every week or daily in dusty conditions
	Grease and Lubricate all moving parts				<input type="radio"/>															
*3	Check fuel hoses and clamp bands				<input type="radio"/>															
*3	Check electrical wiring condition (Damage, defacement and joint looseness)				<input type="radio"/>	<input type="radio"/>														50 hours first check, every 100 hours thereafter
	Check looseness of wheel mounting bolt				<input type="radio"/>	<input type="radio"/>														50 hours first check, every

Maintenance

Maintenance

Maintenance Item		Before Work	After Work	Every Week	Every 50 hrs.	Every 100 hrs.	Every 200 hrs.	Every 250 hrs.	Every 400 hrs.	Every 500 hrs.	Every 800 hrs.	Every 1000 hrs.	Every 1500 hrs.	Every 3000 hrs.	Every month	Every year	Every 2 years	Every 4 years	When Required	Remarks
	Check looseness of wheel mounting bolt				○	○														100 hours thereafter
*3	Change engine oil				●	△														50 hours first check, every 100 hours thereafter
*2	Replace oil filter cartridge				●	△														50 hours first check, every 200 hours thereafter
	Replace hydraulic oil					●				△										100 hours first change, every 500 hours thereafter
*2	Clean air cleaner element (Replace the element after 6-time cleaning)					○										△				Replace every 6 cleanings or every year whichever comes earlier Air cleaner should be cleaned more often in dusty conditions than in normal conditions
*3	Check cracks in cooling fan					○														
	Draining of water separator					○														
*3	Adjust fan belt tension				○	○														50 hours first change, every 100 hours thereafter
*4	Check exterior of battery					○									○					Check every 100 hours or every month whichever comes earlier
*4	Clean exterior of battery					○									○					Check every 100 hours or every month whichever comes earlier

Maintenance

Maintenance Item		Before Work	After Work	Every Week	Every 50 hrs.	Every 100 hrs.	Every 200 hrs.	Every 250 hrs.	Every 400 hrs.	Every 500 hrs.	Every 800 hrs.	Every 1000 hrs.	Every 1500 hrs.	Every 3000 hrs.	Every month	Every year	Every 2 years	Every 4 years	When Required	Remarks	
*4	Check mounting bracket of battery					○									○						Check every 100 hours or every month whichever comes earlier
*4	Check looseness and corrosion of battery terminals					○									○						Check every 100 hours or every month whichever comes earlier
*3	Check battery fluid level					○									○						Check every 100 hours or every month whichever comes earlier
	Replace hydraulic oil filter					●				△											100 hours first change, every 500 hours thereafter
	Replace hydraulic suction filter					●				△											100 hours first change, every 500 hours thereafter
	Check hydraulic hoses condition (Fixed part)						○									○					Check every 200 hours or every year whichever comes earlier
*3	Check radiator hoses and clamp bands						○														
*2	Check intake air line (air cleaner hose)						○														
	Check closed breather hoses						○														
	Grease mower unit hydraulic motor shafts							○													
*3	Clean water separator								○												
*3	Replace fuel filter cartridge								△												
*3	Clean water jacket and radiator interior									○											

Maintenance

Maintenance

Maintenance Item		Before Work	After Work	Every Week	Every 50 hrs.	Every 100 hrs.	Every 200 hrs.	Every 250 hrs.	Every 400 hrs.	Every 500 hrs.	Every 800 hrs.	Every 1000 hrs.	Every 1500 hrs.	Every 3000 hrs.	Every month	Every year	Every 2 years	Every 4 years	When Required	Remarks
*3	Clean fuel tank interior									○										
*3	Replace fan belt									△							△			Replace every 500 hours or 2 years whichever comes earlier
	Replace antivibration rubber for engine											△						△		Replace every 1000 hours or 4 years whichever comes earlier
	Adjust valve clearance											○								
*1.*2	Check injection nozzle												○							
*1.*2	Check turbocharger													○						
*1.*2	Check injection pump													○						
*1	Check DPF-related pipes															○				
*3	Check exhaust manifold (Crack, gas leakage and mounting screw)															○				
	Replace hydraulic hoses (Moving part)																△			
*3	Replace radiator hoses and clamp bands																△			
	Replace fuel hoses and clamps																△			
	Replace intake air line (air cleaner hose)																△			
	Replace closed breather hoses																△			
*3	Change radiator coolant (L.L.C.)																△			
*3	Replace battery																△			
*1	Check DPF-related rubber pipes															○				
	Replace hydraulic hoses (Fixed part)																	△		
	Adjust brake cables																		△	

Maintenance

Maintenance Item	Before Work	After Work	Every Week	Every 50 hrs.	Every 100 hrs.	Every 200 hrs.	Every 250 hrs.	Every 400 hrs.	Every 500 hrs.	Every 800 hrs.	Every 1000 hrs.	Every 1500 hrs.	Every 3000 hrs.	Every month	Every year	Every 2 years	Every 4 years	When Required	Remarks
Replace brake cables																		△	
Replace cables for traveling																		△	
Replace brake pads																		△	

- *1: Consult your local Baroness Dealer or local KUBOTA Dealer for this service.
- The items above (*2 marked) are registered as emission related critical parts by KUBOTA in the U.S. EPA nonroad emission regulation.
As the engine owner, you are responsible for the performance of the required maintenance on the engine according to the above instruction.
Please see the Engine's Warranty Statement in detail.
- *3: Refer to the Engine's Owner's Manual.
- *4: Refer to the Battery's Owner's Manual.
- The values for consumables are not guaranteed.
- Replace the steering cylinder hoses every 2 years.

Adjusted Value

Fan belt			10 mm (0.39 in)	Belt slack
Mower stabilizer spring		#1 - 5	140.0 mm (5.51 in)	Total length of spring
Location of stopper nut	LH62	#1, 4, 5	15.0 mm (0.59 in)	
		#2, 3	40.0 mm (1.57 in)	
	LH52	#1, 4, 5	15.0 mm (0.59 in)	
			30.0 mm (1.18 in)	With grass catcher
		#2, 3	40.0 mm (1.57 in)	

Maintenance

DPF

About DPF

The DPF is a purifying filter that collects PM (soot) from exhaust gas.

When a certain amount of PM (soot) has accumulated, DPF regeneration must be performed automatically or manually in order to restore the filtering function.

DPF Regeneration

Danger

Since it will become extremely hot around the exhaust outlet during DPF regeneration, do not perform the regeneration in a location where fires may occur.

Important

When the system enters the level where DPF regeneration is required, perform the regeneration immediately.

Interrupting the regeneration or ignoring the warning and continuing traveling or cutting work may cause the engine and DPF to malfunction.

Important

Do not repeat unnecessary regeneration or interrupting regeneration.

If repeating them, the measured level of engine oil may increase since the engine oil is mixed with a slight amount of fuel, accompanied by quality degradation.

Important

Perform DPF regeneration when the engine sufficiently warmed up.

DPF regeneration is burning PM (soot) collected in DPF with the exhaust temperature heated up to high temperature by the engine ECU control of intake air mass and fuel injection.

Automatic Regeneration

Danger

Since it will become extremely hot around the exhaust outlet during DPF regeneration, do not perform the regeneration in a location where fires may occur.

Caution

Normally, set the DPF auto regeneration inhibit switch to the "Auto regeneration mode". However, when operating in a location where fires may occur, set the DPF auto regeneration inhibit switch to the "Auto regeneration inhibit mode".

Important

When the system enters the level where DPF regeneration is required, perform the regeneration immediately.

Interrupting the regeneration or ignoring the warning and continuing traveling or cutting work may cause the engine and DPF to malfunction.

Automatic regeneration is the automatic control of increasing the exhaust temperature for DPF regeneration.

- You can continue to use this machine for traveling and cutting work during DPF regeneration.
- You can operate this machine to perform the regeneration. (The fault diagnostic tool is not required.)
- Automatic regeneration is activated only when the auto regeneration inhibit switch set to the "Auto regeneration mode".
- Automatic regeneration is activated when PM accumulation level is "Level 1" or "Level 2".
However, it may be activated in "Level 0" depending on the other condition.

Important

If the regeneration remains uncompleted even after 30 minutes have passed since the start of automatic regeneration in PM accumulation "Level 1", PM accumulation level enters "Level 2".

These are the procedures of automatic regeneration.

■ When the DPF auto regeneration inhibit switch set to the "Auto regeneration mode":

1. When the conditions for automatic regeneration are met, the automatic regeneration starts with the regeneration icon lighting.
2. When the regeneration completed, the regeneration icon disappears.

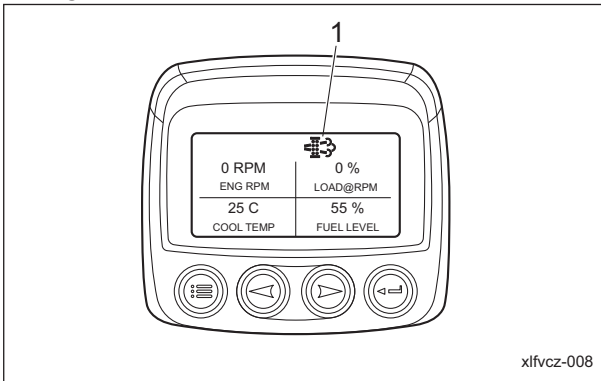

Automatic Regeneration_001

1	Regeneration icon
---	-------------------

■ When the DPF auto regeneration inhibit switch set to the "Auto regeneration inhibit mode":

1. When PM accumulation level enters "Level 1" or "Level 2", the blinking regeneration icon appears.
2. Set the DPF auto regeneration inhibit switch to the "Auto regeneration mode".
3. When the conditions for automatic regeneration are met, the automatic regeneration starts and the regeneration icon changes from blinking to lighting.
4. When the regeneration completed, the regeneration icon disappears.

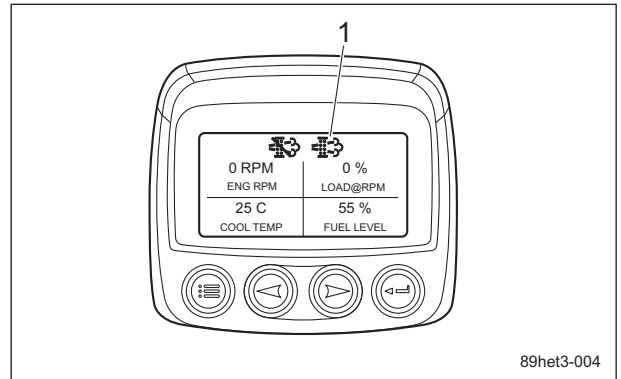

89het3-004

Automatic Regeneration_002

1	Regeneration icon
---	-------------------

Parked Regeneration**⚠ Danger**

Since it will become extremely hot around the exhaust outlet during DPF regeneration, do not perform the regeneration in a location where fires may occur.

Important

When the system enters the level where DPF regeneration is required, perform the regeneration immediately.

Interrupting the regeneration or ignoring the warning and continuing traveling or cutting work may cause the engine and DPF to malfunction.

Parked regeneration is the DPF regeneration forcibly performed, parking this machine in a safe location, when auto regeneration does not reduce the amount of accumulated PM to the specified value.

- You can not continue to use this machine for traveling and cutting work during DPF regeneration.
- You can operate this machine to perform the regeneration. (The fault diagnostic tool is not required.)
- These are the conditions for activating parked regeneration.
 1. The parking brake is applied.
 2. The traveling pedal is in neutral.
 3. The throttle opening is 0% (idling).
- Parked regeneration is activated when PM accumulation level is "Level 2" or "Level 3".

Maintenance

Important

If the regeneration remains uncompleted in automatic regeneration, parked regeneration is required with the blinking regeneration icon.

■ In PM accumulation "Level 2":

Important

If ignoring the parked regeneration requirement and continuing traveling or cutting work in PM accumulation "Level 2", PM accumulation level enters "Level 3".

Follow the steps below for parked regeneration.

1. When PM accumulation level enters "Level 2", the blinking regeneration icon appears. When the DPF auto regeneration inhibit switch set to the "Auto regeneration mode":

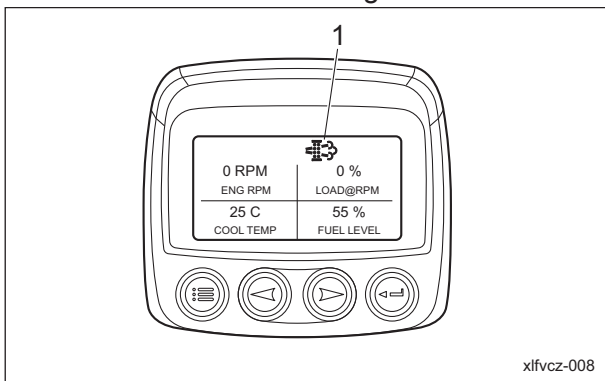

Parked Regeneration_001

1	Regeneration icon
---	-------------------

When the DPF auto regeneration inhibit switch set to the "Auto regeneration inhibit mode":

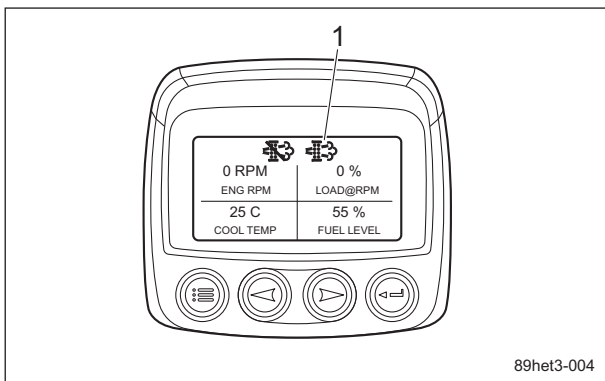

Parked Regeneration_002

1	Regeneration icon
---	-------------------

2. Stop traveling and cutting work.
3. Park this machine in a safe location.

4. Apply the parking brake.
5. Set the throttle opening to 0% (idling).
6. Press the DPF parked regeneration switch to the "Parked regeneration (actuation)" side.
 - Parked regeneration starts and the regeneration icon changes from blinking to lighting.
7. When the regeneration completed, the regeneration icon disappears.

■ In PM accumulation "Level 3":

Important

If ignoring the parked regeneration requirement and continuing traveling or cutting work in PM accumulation "Level 3", PM accumulation level enters "Level 4". If still continuing traveling or cutting work, you will not be able to operate this machine for regeneration.

Important

Automatic regeneration can not be activated in PM accumulation "Level 3". Perform parked regeneration immediately.

1. These are the statuses in PM accumulation "Level 3".
 - "Excessive PM3" appears in the monitor display. Pressing an arrow key changes the display to "CORRECTIVE ACTION: Start DPF Parked Regeneration immediately".
 - The LED (yellow) lights up.
 - The engine output is limited at 50%.

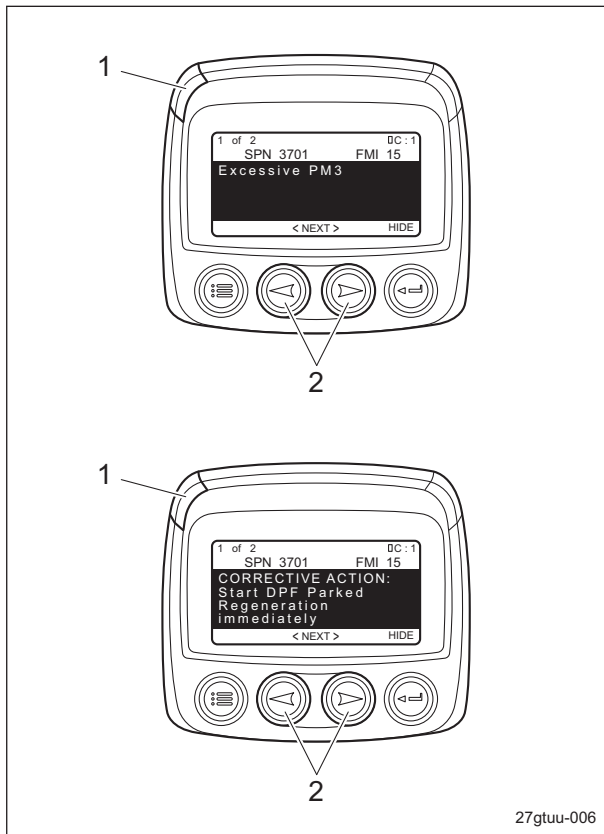

Parked Regeneration_003

1	LED (yellow)
2	Arrow key

2. Stop traveling and cutting work.
3. Park this machine in a safe location.
4. Apply the parking brake.
5. Set the throttle opening to 0% (idling).
6. Press the DPF parked regeneration switch to the "Parked regeneration (actuation)" side.
Parked regeneration starts and the regeneration icon changes from blinking to lighting.
7. When the regeneration completed, the regeneration icon disappears.

Manual Regeneration

⚠ Danger

Since it will become extremely hot around the exhaust outlet during DPF regeneration, do not perform the regeneration in a location where fires may occur.

Important

When the system enters the level where DPF regeneration is required, perform the regeneration immediately. Interrupting the regeneration or ignoring the warning and continuing traveling or cutting work may cause the engine and DPF to malfunction.

Manual regeneration is the DPF regeneration performed only by the expert with the fault diagnostic tool. Normal automatic regeneration or parked regeneration can not complete regeneration since large amount of PM accumulates.

Manual regeneration can be activated in any PM accumulation level.

- You can not continue to use this machine for traveling and cutting work during DPF regeneration.
- You can not perform the regeneration. (The fault diagnostic tool is required.)
- Manual regeneration is activated in PM accumulation "Level 4".
- Manual regeneration is activated in any PM accumulation level when the following condition met.
 1. when replacing DPF
 2. when replacing ECU

Maintenance

■ In PM accumulation "Level 4":

Important

If ignoring the manual regeneration requirement and continuing traveling or cutting work in PM accumulation "Level 4", PM accumulation level enters "Level 5". If still continuing traveling or cutting work, fatal trouble will occur on the engine and DPF.

1. These are the statuses in PM accumulation "Level 4".

- "Excessive PM4" appears in the monitor display.
Pressing an arrow key changes the display to "CORRECTIVE ACTION: Stop engine!! Contact dealer immediately".
- The LED (yellow) lights up.
- The engine output is limited at 50%.

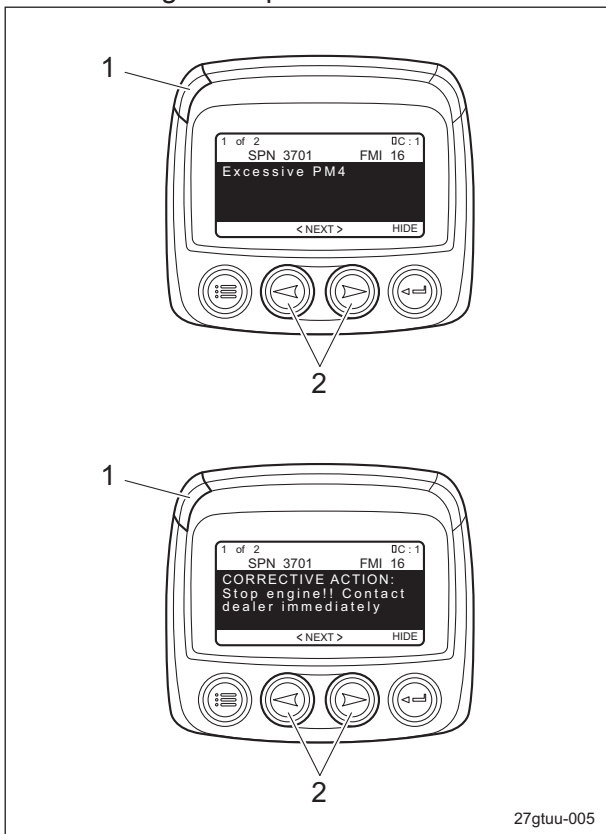

Manual Regeneration_001

1	LED (yellow)
2	Arrow key

2. Stop traveling and cutting work.
3. Park this machine in a safe location.
4. Apply the parking brake.
5. Stop the engine.

6. Contact your dealer for manual regeneration.

Replacement of DPF

When PM accumulates excessively in the DPF or ash accumulates, replace the DPF since the regeneration in that case is prohibited.

- You can not continue to use this machine for traveling and cutting work.
- The regeneration is impossible.
- Replace DPF in PM accumulation "Level 5".

1. These are the statuses in PM accumulation "Level 5".

- "Excessive PM5" appears in the monitor display.
Pressing an arrow key changes the display to "CORRECTIVE ACTION: Stop engine!! Contact dealer immediately".
- The LED (red) lights up.
- The engine output is limited at 50%.

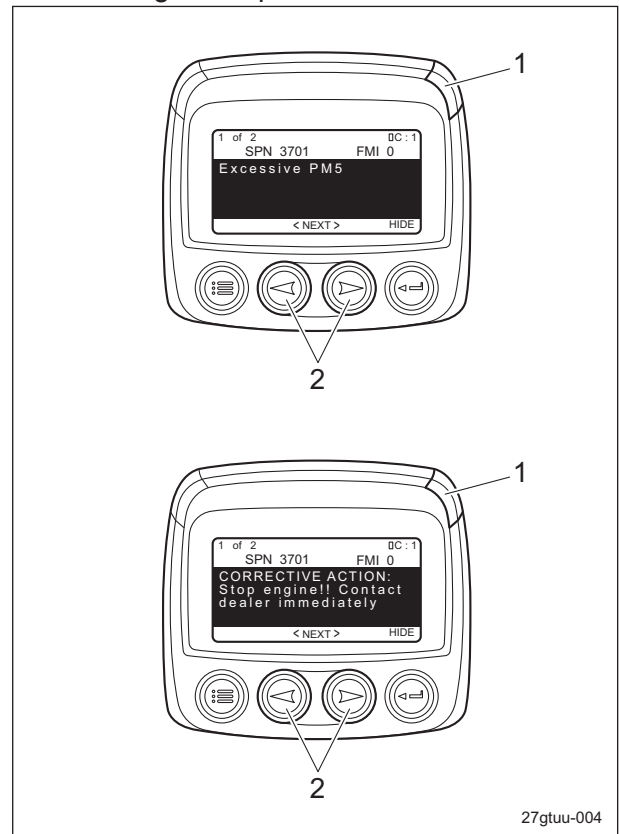

Replacement of DPF_001

1	LED (red)
2	Arrow key

2. Stop traveling and cutting work.
3. Park this machine in a safe location.
4. Apply the parking brake.
5. Stop the engine.

6. Contact your dealer for DPF replacement.

Conditions for DPF Regeneration

Danger

Since it will become extremely hot around the exhaust outlet during DPF regeneration, do not perform the regeneration in a location where fires may occur.

Important

If DPF regeneration is interrupted before it is completed, the next regeneration may be requested soon since not all of the PM (soot) was removed.

Important

The DPF regeneration can not be activated in case of low battery voltage.

Important

Perform DPF regeneration when the engine sufficiently warmed up.

1. DPF auto regeneration does not begin unless both of the following two conditions are met.
 - The DPF auto regeneration inhibit switch is set to the "Auto regeneration mode". (Auto regeneration inhibit icon is turned off.)
 - The coolant temperature is 65 °C or more.
2. DPF parked regeneration and manual regeneration do not begin unless all of the following four conditions are met.
 - The parking brake is applied.
 - The traveling pedal is in the neutral position.
 - The throttle opening is 0% (idling).
 - The coolant temperature is 65 °C or more.
3. During DPF regeneration, the operation is canceled if any of the following conditions occur.
 - Any condition for starting regeneration is violated.
 - The ignition key is switched to the "OFF" position.

PM Accumulation Level

■ Level 0

DPF regeneration is not necessary.

■ Level 1

Danger

Since it will become extremely hot around the exhaust outlet during DPF regeneration, do not perform the regeneration in a location where fires may occur.

Caution

Normally, set the DPF auto regeneration inhibit switch to the "Auto regeneration mode". However, when operating in a location where fires may occur, set the DPF auto regeneration inhibit switch to the "Auto regeneration inhibit mode".

Important

When the system enters the level where DPF regeneration is required, perform the regeneration immediately. Interrupting the regeneration or ignoring the warning and continuing traveling or cutting work may cause the engine and DPF to malfunction.

Important

If the regeneration remains uncompleted even after 30 minutes have passed since the start of automatic regeneration in PM accumulation "Level 1", PM accumulation level enters "Level 2".

- You can continue to use this machine for traveling and cutting work during DPF regeneration.
 - You can operate this machine to perform the regeneration. (The fault diagnostic tool is not required.)
- When the DPF auto regeneration inhibit switch set to the "Auto regeneration mode":
1. When the conditions for automatic regeneration are met, the automatic regeneration starts with the regeneration icon lighting.

Maintenance

- When the regeneration completed, the regeneration icon disappears.

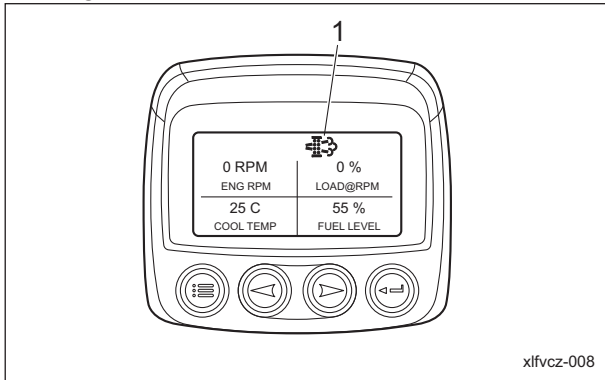

xlfvcz-008

Level 1_001

1	Regeneration icon
---	-------------------

■ When the DPF auto regeneration inhibit switch set to the "Auto regeneration inhibit mode":

- The blinking regeneration icon appears.
- Set the DPF auto regeneration inhibit switch to the "Auto regeneration mode".
- When the conditions for automatic regeneration are met, the automatic regeneration starts and the regeneration icon changes from blinking to lighting.
- When the regeneration completed, the regeneration icon disappears.

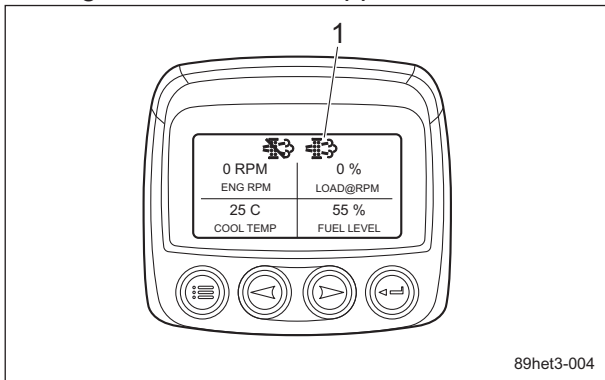

89het3-004

Level 1_002

1	Regeneration icon
---	-------------------

■ Level 2

⚠ Danger

Since it will become extremely hot around the exhaust outlet during DPF regeneration, do not perform the regeneration in a location where fires may occur.

⚠ Caution

Normally, set the DPF auto regeneration inhibit switch to the "Auto regeneration mode". However, when operating in a location where fires may occur, set the DPF auto regeneration inhibit switch to the "Auto regeneration inhibit mode".

Important

When the system enters the level where DPF regeneration is required, perform the regeneration immediately.

Interrupting the regeneration or ignoring the warning and continuing traveling or cutting work may cause the engine and DPF to malfunction.

Important

If ignoring the parked regeneration requirement and continuing traveling or cutting work in PM accumulation "Level 2", PM accumulation level enters "Level 3".

- You can continue to use this machine for traveling and cutting work during DPF auto regeneration.
- You can not continue to use this machine for traveling and cutting work during DPF parked regeneration.
- You can operate this machine to perform the regeneration. (The fault diagnostic tool is not required.)

<Automatic regeneration>

■ When the DPF auto regeneration inhibit switch set to the "Auto regeneration mode":

- When the conditions for automatic regeneration are met, the automatic regeneration starts with the regeneration icon lighting.
- When the regeneration completed, the regeneration icon disappears.

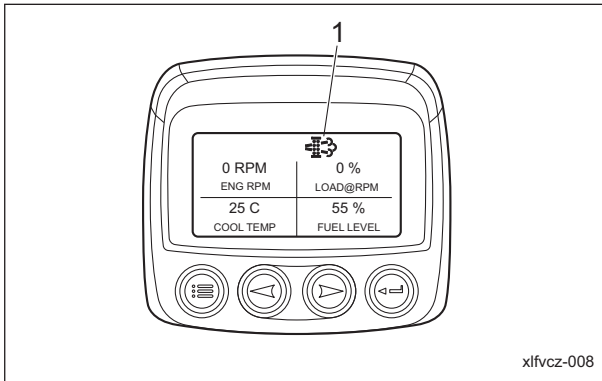

Level 2_001

1	Regeneration icon
---	-------------------

■ When the DPF auto regeneration inhibit switch set to the "Auto regeneration inhibit mode":

1. The blinking regeneration icon appears.
2. Set the DPF auto regeneration inhibit switch to the "Auto regeneration mode".
3. When the conditions for automatic regeneration are met, the automatic regeneration starts and the regeneration icon changes from blinking to lighting.
4. When the regeneration completed, the regeneration icon disappears.

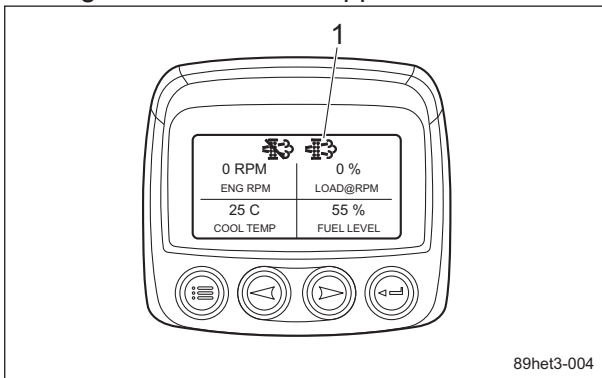

Level 2_002

1	Regeneration icon
---	-------------------

<Parked regeneration>

- These are the conditions for activating parked regeneration.
 1. The parking brake is applied.
 2. The traveling pedal is in neutral.
 3. The throttle opening is 0% (idling).
- 1. The blinking regeneration icon appears. When the DPF auto regeneration inhibit switch set to the "Auto regeneration mode":

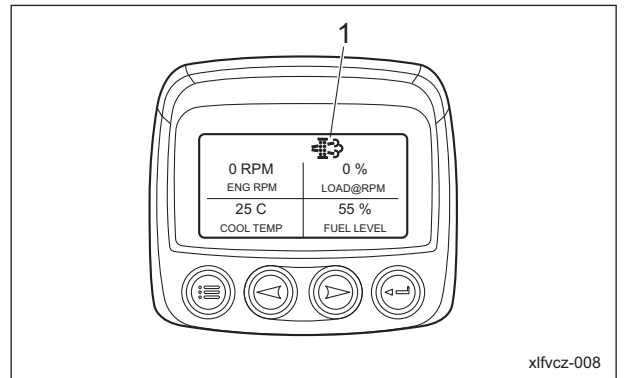

Level 2_003

1	Regeneration icon
---	-------------------

When the DPF auto regeneration inhibit switch set to the "Auto regeneration inhibit mode":

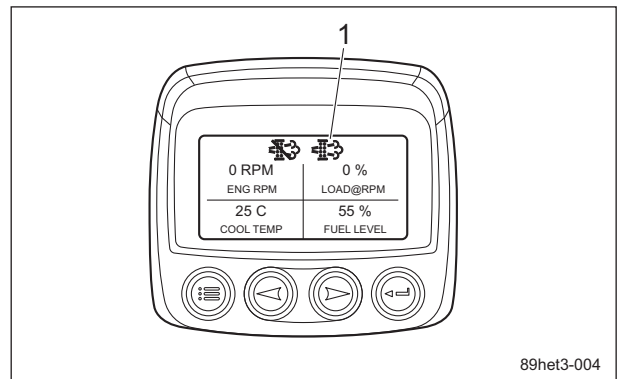

Level 2_004

1	Regeneration icon
---	-------------------

2. Stop traveling and cutting work.
3. Park this machine in a safe location.
4. Apply the parking brake.
5. Set the throttle opening to 0% (idling).
6. Press the DPF parked regeneration switch to the "Parked regeneration (actuation)" side. Parked regeneration starts and the regeneration icon changes from blinking to lighting.

Maintenance

7. When the regeneration completed, the regeneration icon disappears.

Level 3

Danger

Since it will become extremely hot around the exhaust outlet during DPF regeneration, do not perform the regeneration in a location where fires may occur.

Important

When the system enters the level where DPF regeneration is required, perform the regeneration immediately. Interrupting the regeneration or ignoring the warning and continuing traveling or cutting work may cause the engine and DPF to malfunction.

Important

If ignoring the parked regeneration requirement and continuing traveling or cutting work in PM accumulation "Level 3", PM accumulation level enters "Level 4". If still continuing traveling or cutting work, you will not be able to operate this machine for regeneration.

Important

Automatic regeneration can not be activated in PM accumulation "Level 3". Perform parked regeneration immediately.

- You can not continue to use this machine for traveling and cutting work during DPF regeneration.
- You can operate this machine to perform the regeneration. (The fault diagnostic tool is not required.)

1. These are the statuses in PM accumulation "Level 3".

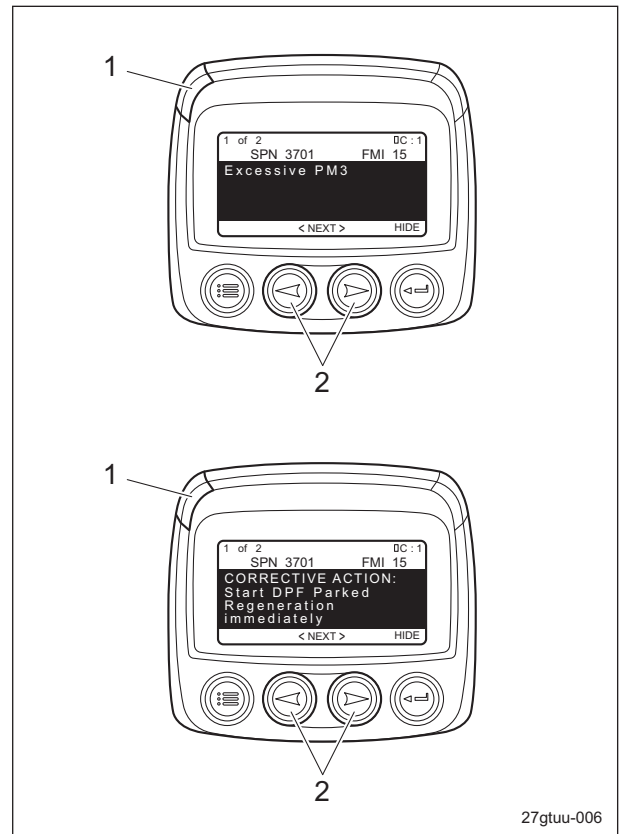

27gtuu-006

Level 3_001

1	LED (yellow)
2	Arrow key

- "Excessive PM3" appears in the monitor display.

Pressing an arrow key changes the display to "CORRECTIVE ACTION: Start DPF Parked Regeneration immediately".

- The LED (yellow) lights up.
- The engine output is limited at 50%.

2. Stop traveling and cutting work.
3. Park this machine in a safe location.
4. Apply the parking brake.
5. Set the throttle opening to 0% (idling).
6. Press the DPF parked regeneration switch to the "Parked regeneration (actuation)" side.
Parked regeneration starts and the regeneration icon changes from blinking to lighting.
7. When the regeneration completed, the regeneration icon disappears.

■Level 4

⚠ Danger

Since it will become extremely hot around the exhaust outlet during DPF regeneration, do not perform the regeneration in a location where fires may occur.

Important

When the system enters the level where DPF regeneration is required, perform the regeneration immediately. Interrupting the regeneration or ignoring the warning and continuing traveling or cutting work may cause the engine and DPF to malfunction.

Important

If ignoring the manual regeneration requirement and continuing traveling or cutting work in PM accumulation "Level 4", PM accumulation level enters "Level 5". If still continuing traveling or cutting work, fatal trouble will occur on the engine and DPF.

- You can not continue to use this machine for traveling and cutting work during DPF regeneration.
- You can not perform the regeneration. (The fault diagnostic tool is required.)

1. These are the statuses in PM accumulation "Level 4".

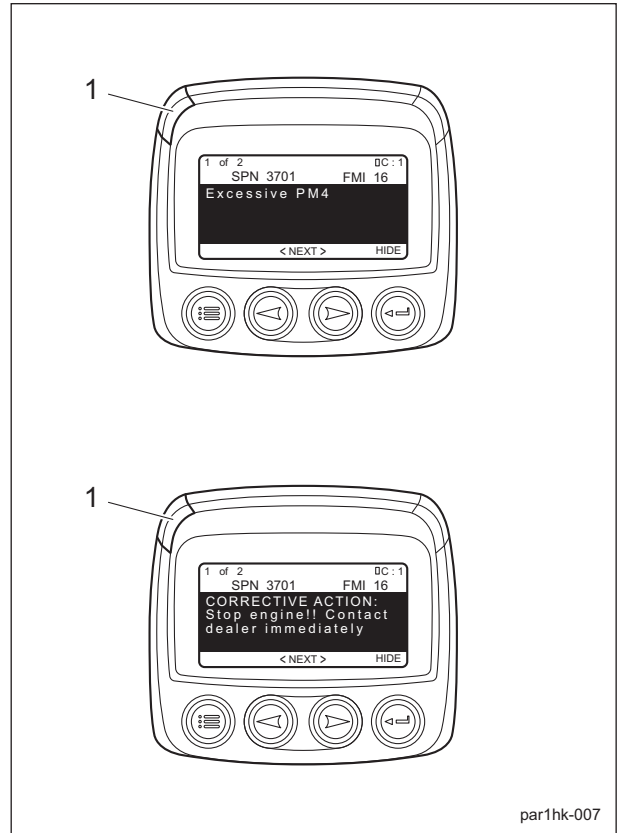

Level 4_001

1	LED (yellow)
2	Arrow key

- "Excessive PM4" appears in the monitor display. Pressing an arrow key changes the display to "CORRECTIVE ACTION: Stop engine!! Contact dealer immediately".

- The LED (yellow) lights up.
- The engine output is limited at 50%.

2. Stop traveling and cutting work.
3. Park this machine in a safe location.
4. Apply the parking brake.
5. Stop the engine.
6. Contact your dealer for manual regeneration.

■Level 5

When PM accumulates excessively in the DPF or ash accumulates, replace the DPF since the regeneration in that case is prohibited.

- You can not continue to use this machine for traveling and cutting work.

Maintenance

- The regeneration is impossible.

1. These are the statuses in PM accumulation "Level 5".

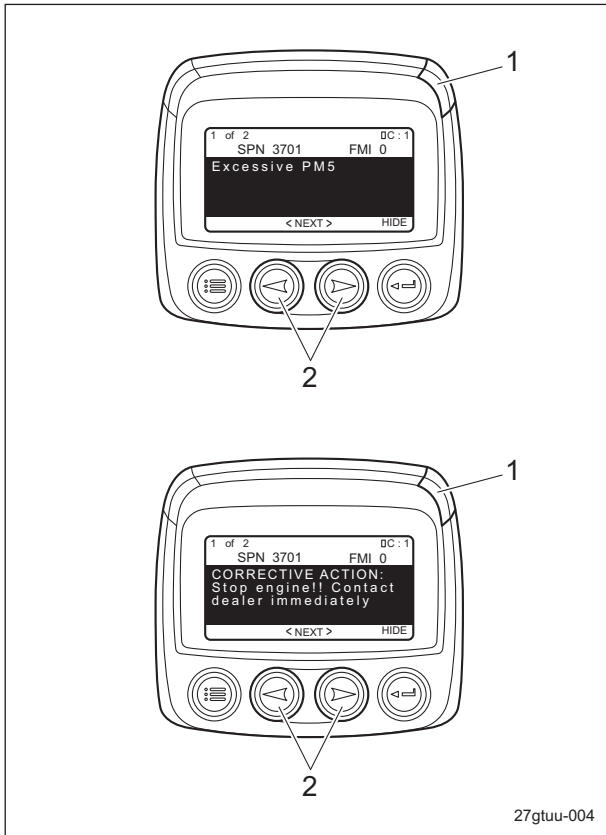

27gtuu-004

Level 5_001

1	LED (red)
2	Arrow key

- "Excessive PM5" appears in the monitor display.
Pressing an arrow key changes the display to "CORRECTIVE ACTION: Stop engine!! Contact dealer immediately".
- The LED (red) lights up.
- The engine output is limited at 50%.

2. Stop traveling and cutting work.
3. Park this machine in a safe location.
4. Apply the parking brake.
5. Stop the engine.
6. Contact your dealer for DPF replacement.

Jacking Up The Machine

About Jacking Up The Machine

Warning

When replacing a tire or beginning any other maintenance or repairs, be sure to chock the wheels to prevent the machine from moving. Before jacking up the machine, park it on a hard, flat surface such as a concrete floor and remove any obstacles that could prevent you from performing the work safely.

When necessary, use an appropriate chain block, hoist, or jack.

Support the machine securely with jack stands or appropriate blocks.

Failure to do so may cause the machine to move or fall, resulting in injury or death.

Use the jack-up points identified in this manual when jacking up the machine.

Only place a jack under the jack-up points specified.

Placing a jack at any other point could result in damage to the frame or other parts.

Jack-up Points

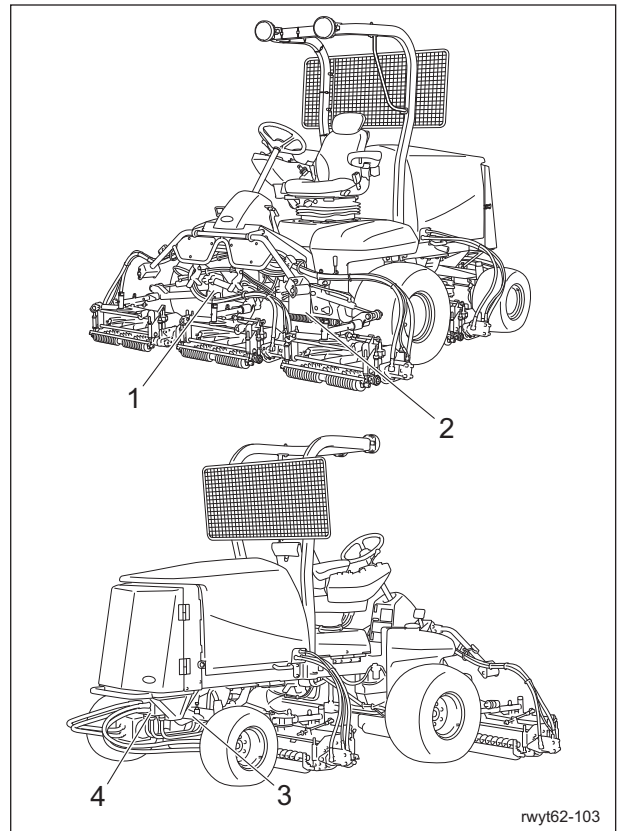

rwyt62-103

Jack-up Points_001

	Jack-up Points
1	Front right frame
2	Front left frame
3	Right pivot
4	Left pivot

1. Front right frame

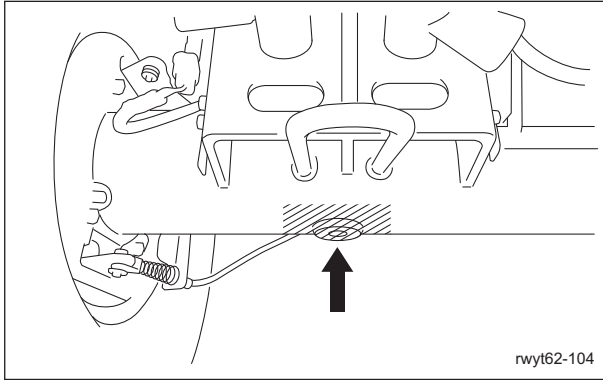

Jack-up Points_002

2. Front left frame

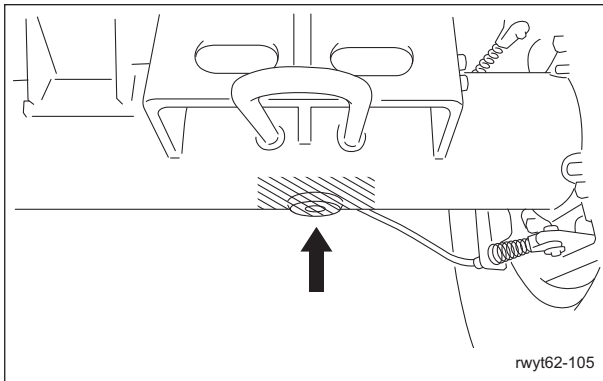

Jack-up Points_003

3. Right pivot

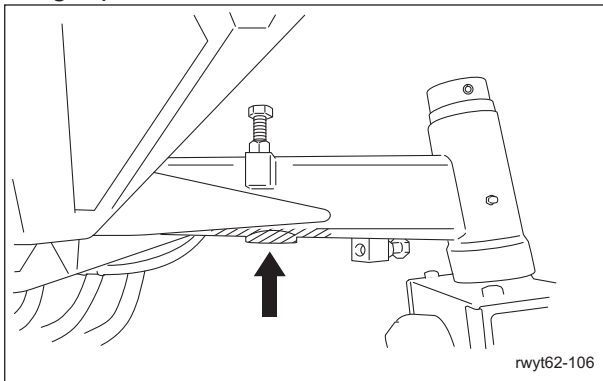

Jack-up Points_004

When jacking up the machine at the right pivot, place a block of wood between the right pivot and the frame.

Note:

Use a block of wood with a height of approximately 130 mm (5.12 in).

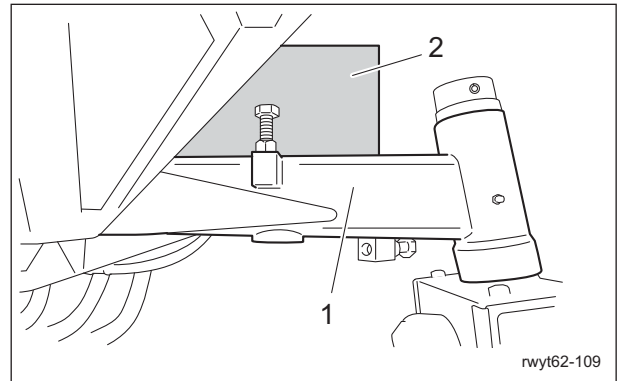

Jack-up Points_005

1	Pivot
2	Block of wood

4. Left pivot

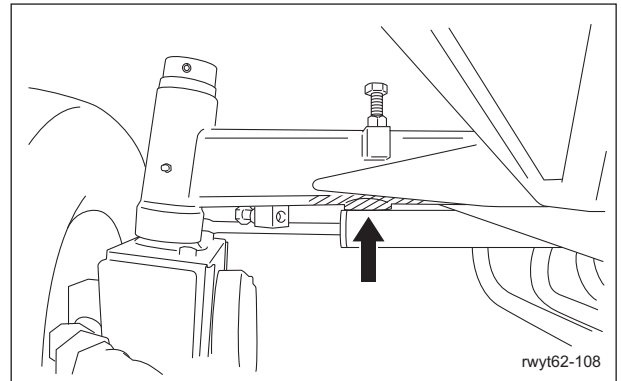

Jack-up Points_006

When jacking up the machine at the left pivot, place a block of wood between the left pivot and the frame.

Note:

Use a block of wood with a height of approximately 130 mm (5.12 in).

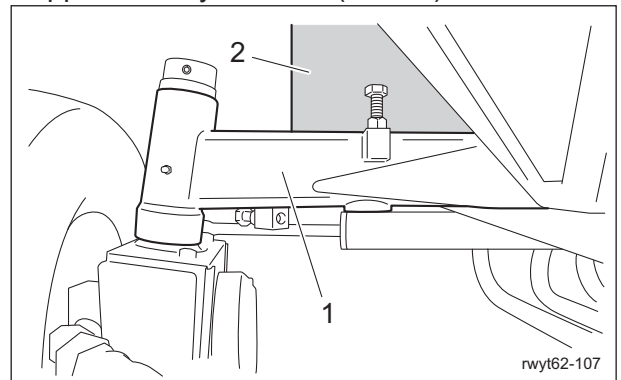

Jack-up Points_007

1	Pivot
2	Block of wood

Maintenance

Greasing

About Greasing

Since there may be adhesion or damage due to lack of grease on moving parts, they must be greased.

Add urea-based No. 2 grease in accordance with the Maintenance Schedule.

Other locations where the specified grease or lubricant is used are indicated in "Greasing Points".

Add grease using the specified grease or lubricant.

Greasing Points

Grease nipples are installed in the following locations.

Add grease every 50 hours of operation.

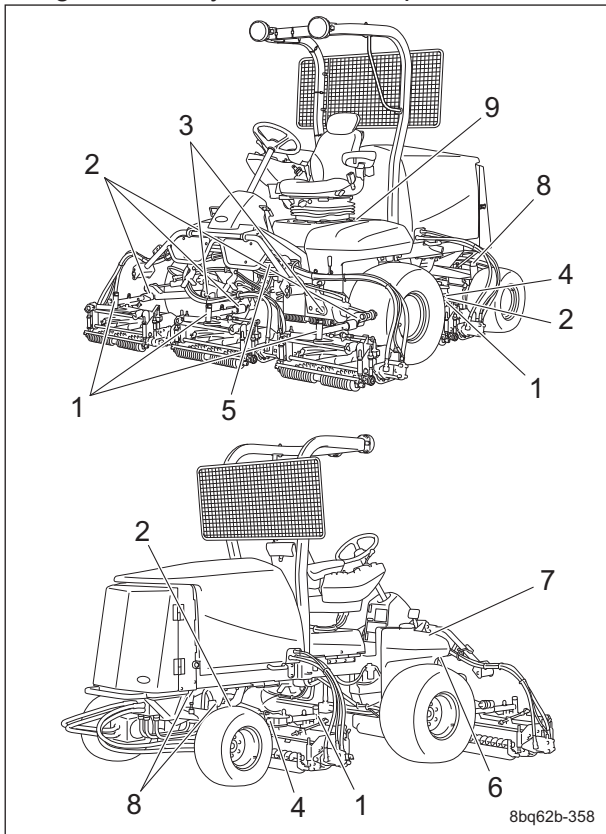

Greasing Points_001

	Location	No. of greasing points
1	Mower arm fulcrum	5
2	Lift arm fulcrum	5
3	Lift arm fulcrum shaft	3
4	Swiveling bracket fulcrum	2
5	Brake pedal shaft fulcrum	1
6	Traveling pedal shaft fulcrum	1
7	Operating speed stopper	1
8	Pivot	3
9	Joint	1

1. Mower arm fulcrum

There is one greasing point on each mower arm fulcrum.

Mower unit #1

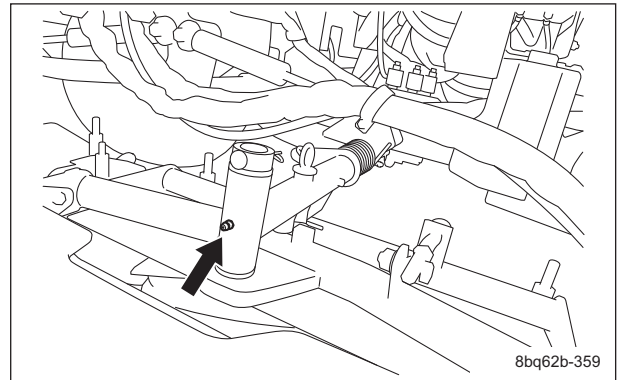

Greasing Points_002

Mower unit #2

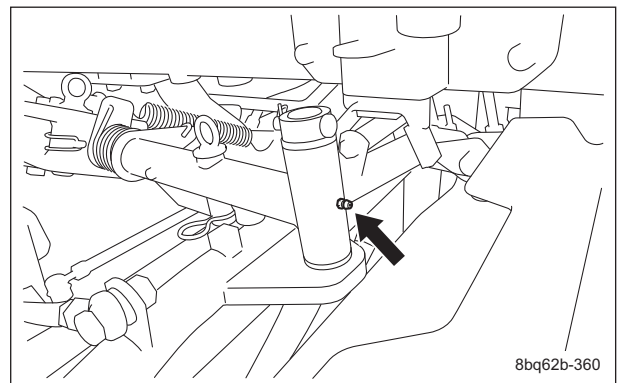

Greasing Points_003

Mower unit #3

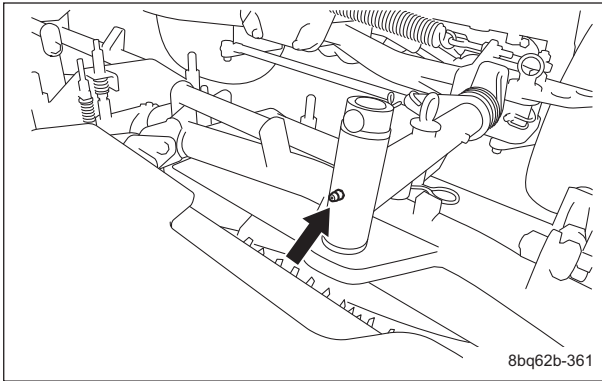

Greasing Points_004

Mower unit #4

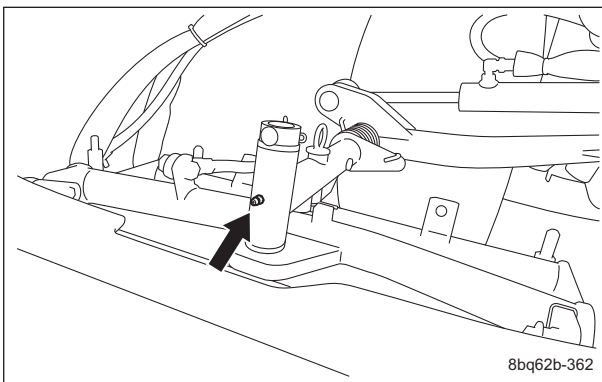

Greasing Points_005

Mower unit #5

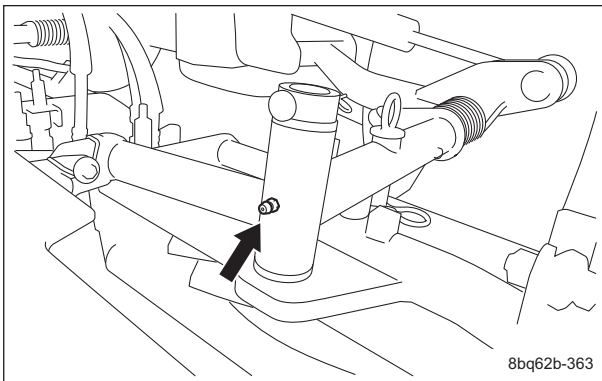

Greasing Points_006

2. Lift arm fulcrum

There is one greasing point on each lift arm fulcrum connected to the mower unit.

Mower unit #1

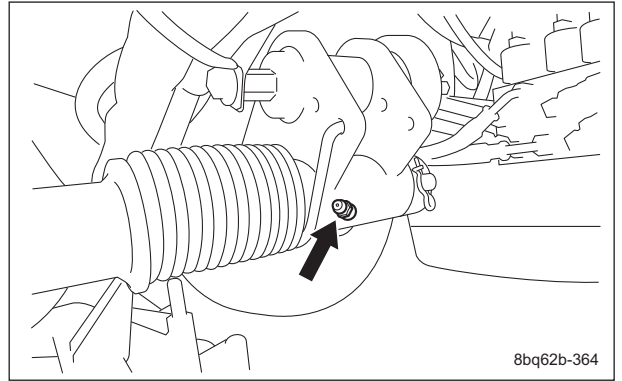

Greasing Points_007

Mower unit #2

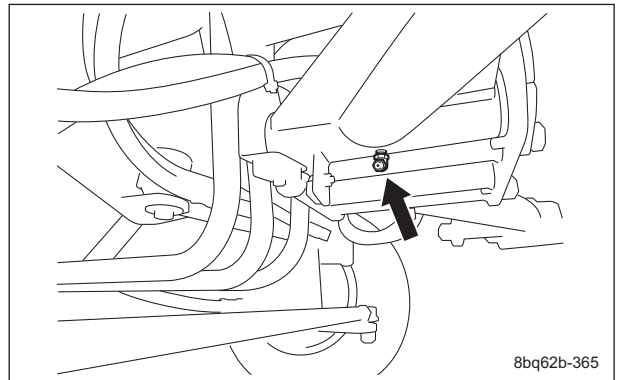

Greasing Points_008

Mower unit #3

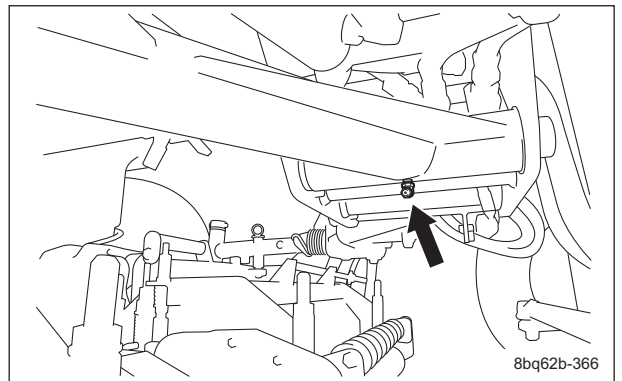

Greasing Points_009

Maintenance

Mower unit #4

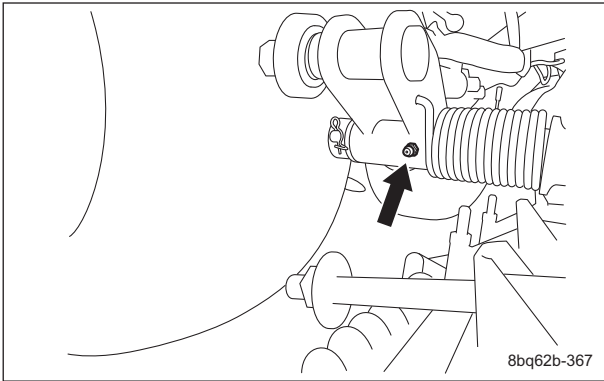

Greasing Points_010

Mower unit #5

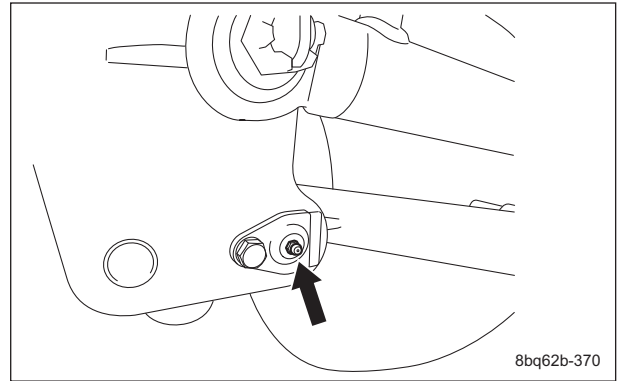

Greasing Points_013

Mower unit #5

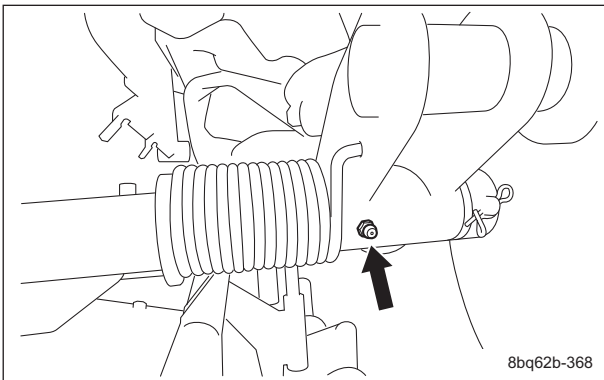

Greasing Points_011

4. Swiveling bracket fulcrum

There is one greasing point on each swiveling bracket fulcrum connected to the mower unit.

Mower unit #2

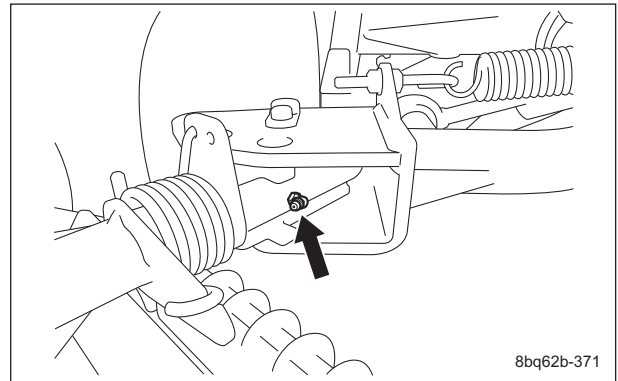

Greasing Points_014

3. Lift arm fulcrum shaft

There is one greasing point on each lift arm fulcrum shaft connected to the mower unit.

Mower units #1 and #4

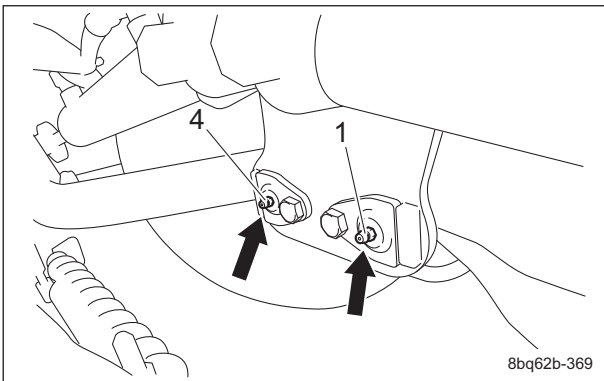

Greasing Points_012

1	Mower unit #1
2	Mower unit #4

Mower unit #3

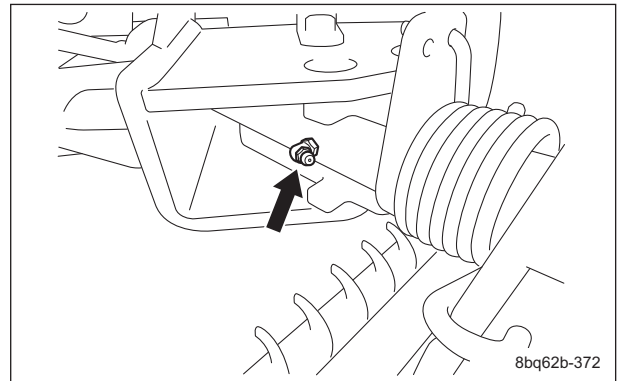

Greasing Points_015

5. Brake pedal shaft fulcrum

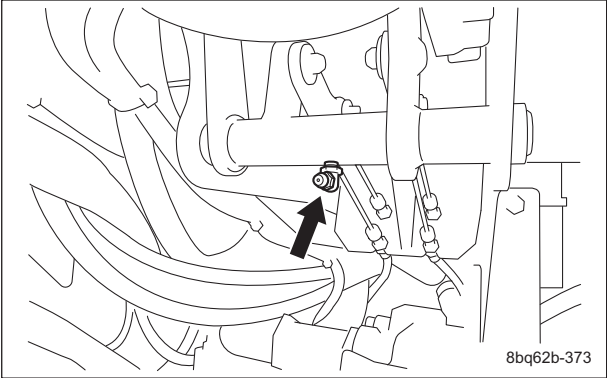

Greasing Points_016

Rear wheel Left

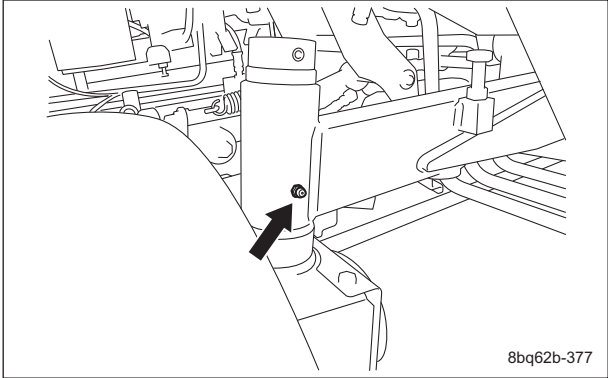

Greasing Points_020

6. Traveling pedal shaft fulcrum

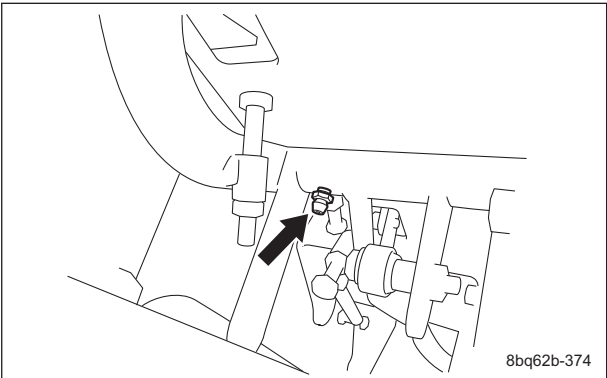

Greasing Points_017

Rear wheel Right

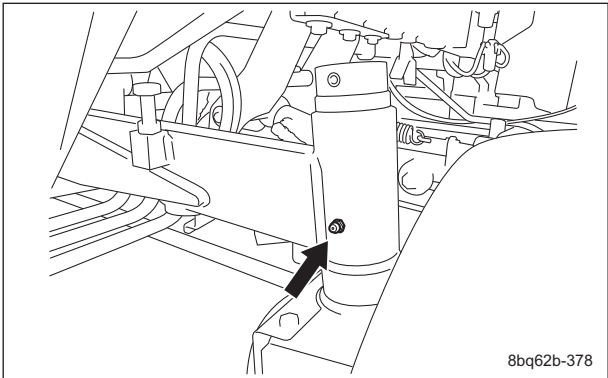

Greasing Points_021

7. Operating speed stopper

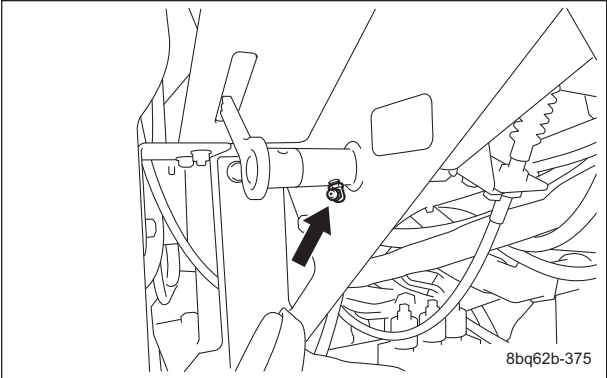

Greasing Points_018

9. Joint

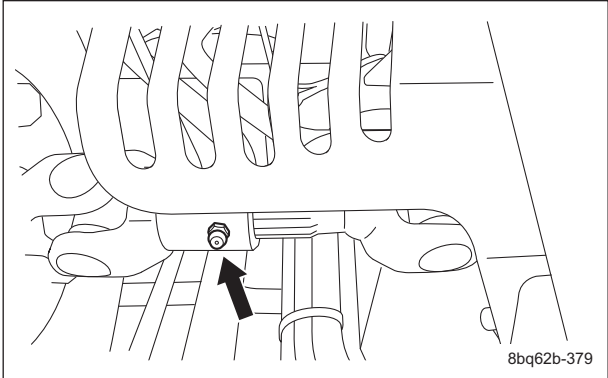

Greasing Points_022

8. Pivot

Rear wheel Middle

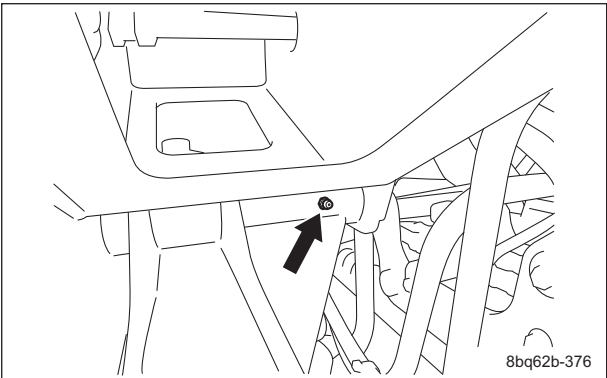

Greasing Points_019

Maintenance

Maintenance

Lubrication

About Lubrication

It is necessary to lubricate moving parts so that they will not become stuck or damaged. The locations where lubricant is used are indicated in "Lubricating Points". Apply the lubricant.

Lubricating Points

Apply lubricant at the following locations every 50 hours of operation.

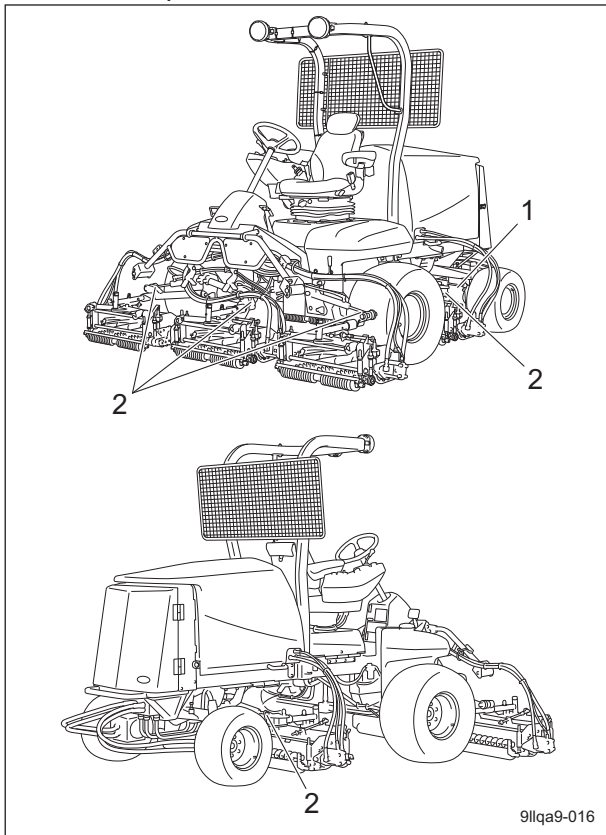

Lubricating Points_001

	Location	No. of greasing points
1	Steering cylinder spherical bearing	2
2	Mower cylinder spherical bearing	10

1. Steering cylinder spherical bearing

There are two locations.

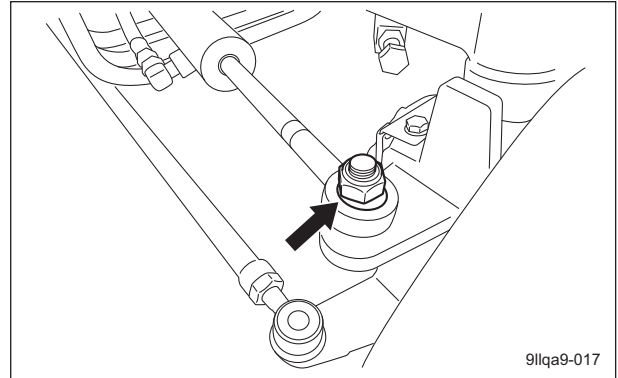

9llqa9-017

Lubricating Points_002

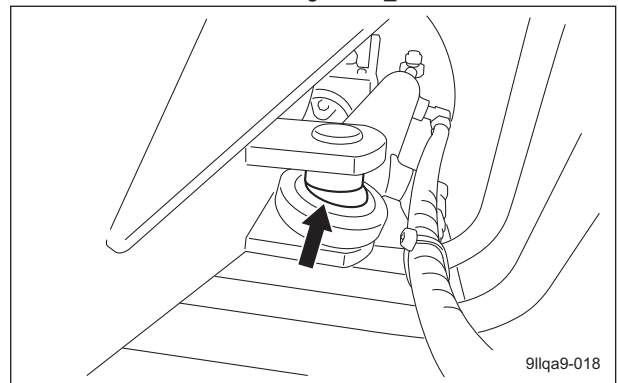

9llqa9-018

Lubricating Points_003

2. Mower cylinder spherical bearing

There are two locations on each mower cylinder.

Mower unit #1

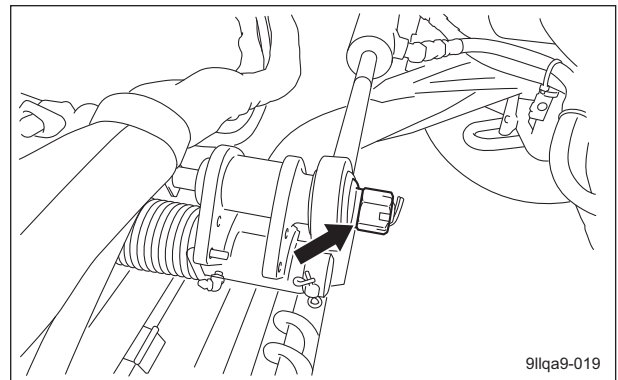

9llqa9-019

Lubricating Points_004

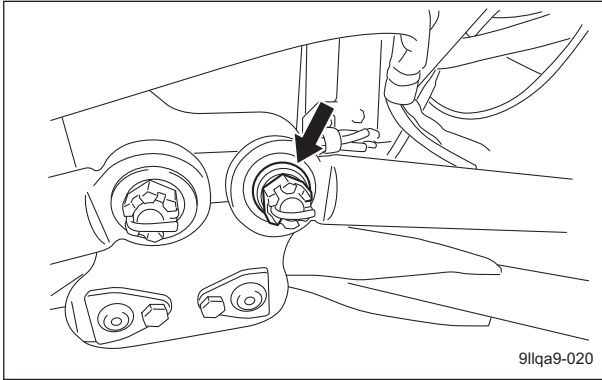

Lubricating Points_005

Mower unit #2

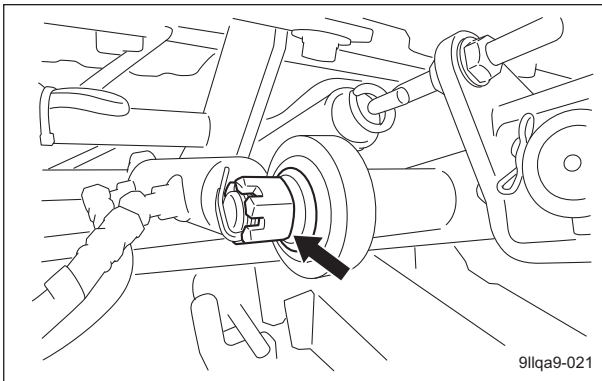

Lubricating Points_006

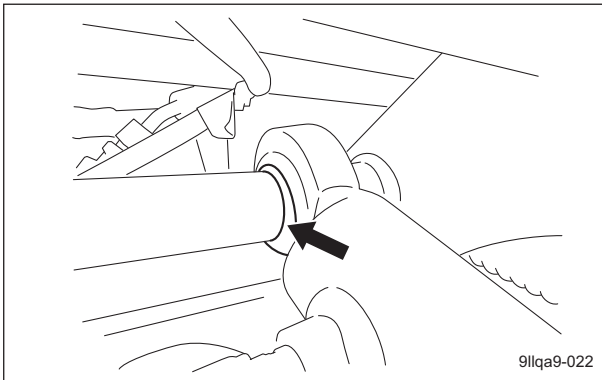

Lubricating Points_007

Mower unit #3

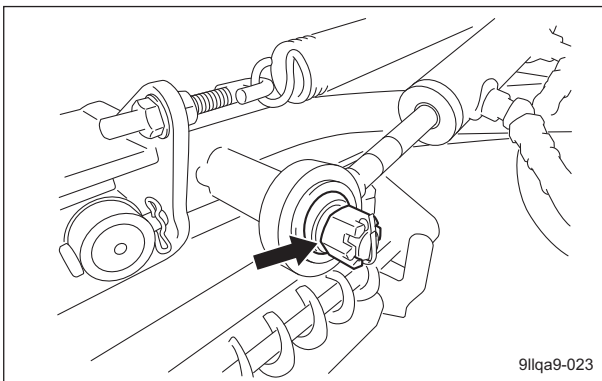

Lubricating Points_008

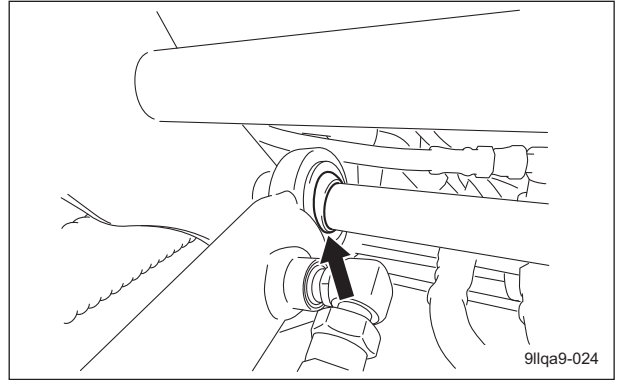

Lubricating Points_009

Mower unit #4

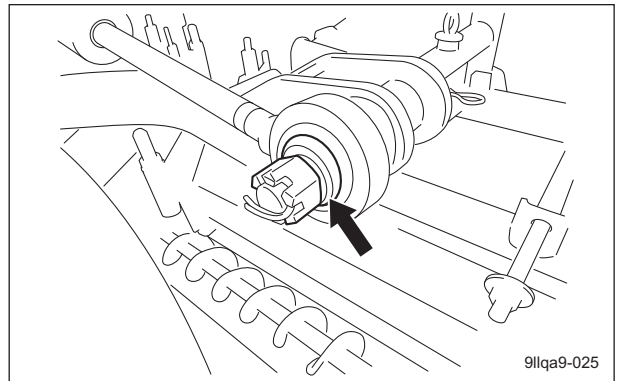

Lubricating Points_010

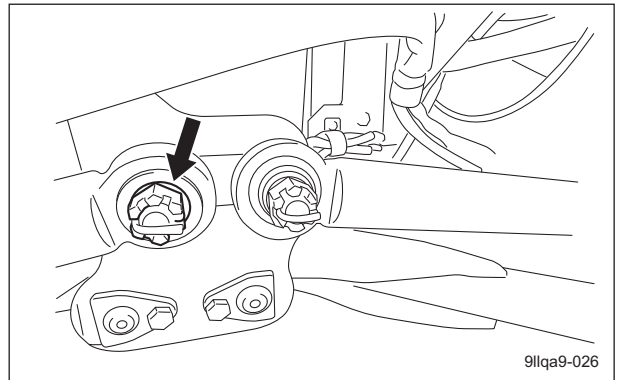

Lubricating Points_011

Mower unit #5

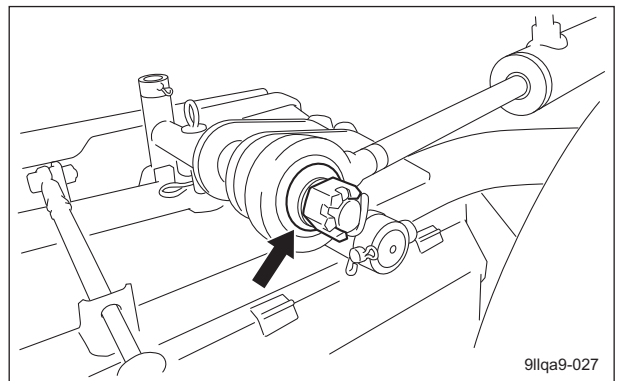

Lubricating Points_012

Maintenance

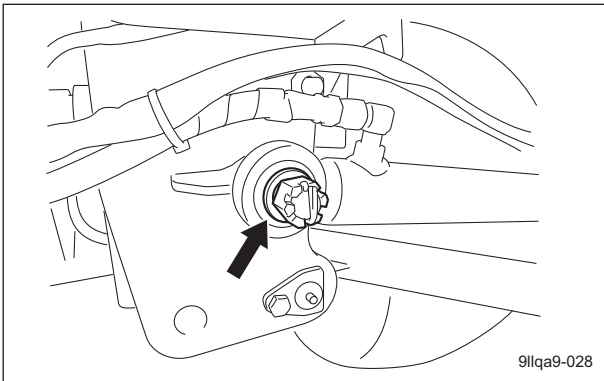

Lubricating Points_013

Maintenance Work

Swiveling Mower Units #2 and #3

⚠ Caution

Both the reel cutter (cutting cylinder) and the bed knife (bottom blade) are edged tools. Handle them carefully, since they could cut your hands or legs.

⚠ Caution

Be careful not to inhale exhaust gas while swiveling the mower units.

Maintenance can be performed more easily with mower units #2 and #3 swiveled.

1. Lower the mower units, and then stop the engine.
2. Remove the pipe pin, and then remove the grip pin.

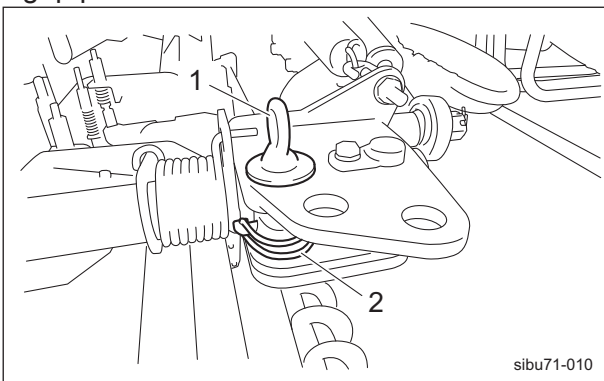

Swiveling Mower Units #2 and #3_001

1	Grip pin
2	Pipe pin

3. Swivel the mower unit toward the outside of the machine.

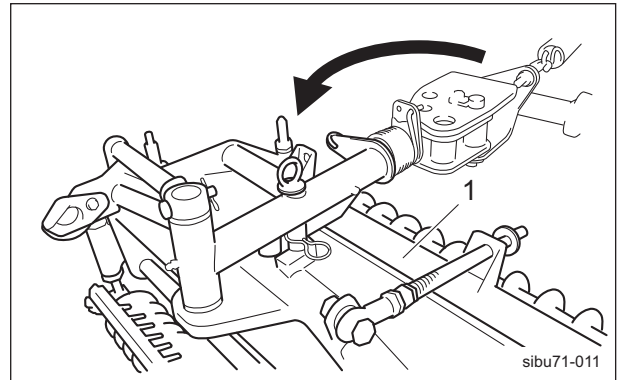

Swiveling Mower Units #2 and #3_002

1	Mower unit
---	------------

4. Fully insert the grip pin into the locking hole for maintenance, and then install the pipe pin in the grip pin. The installation location for the locking hole for maintenance differs depending on whether the mower unit is installed in the front or rear position.

Mower unit position: Front
Use the rear locking hole (A) for maintenance.

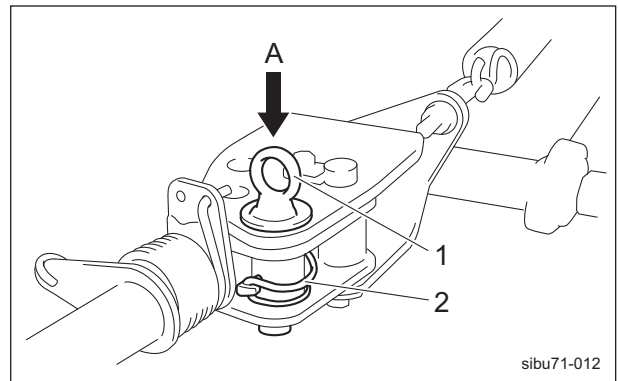

Swiveling Mower Units #2 and #3_003

1	Grip pin
2	Pipe pin

Mower unit position: Rear
Use the center locking hole (B) for maintenance.

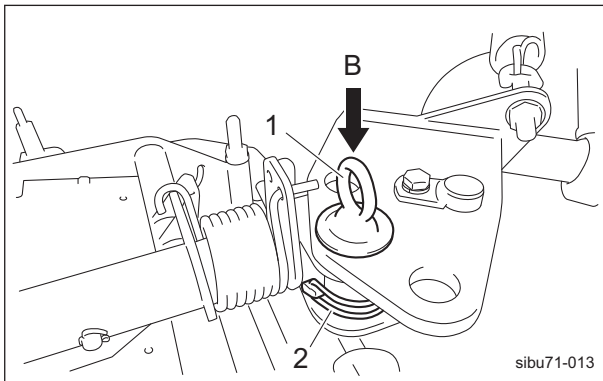

Swiveling Mower Units #2 and #3_004

1	Grip pin
2	Pipe pin

5. Start the engine, and then raise the mower units.

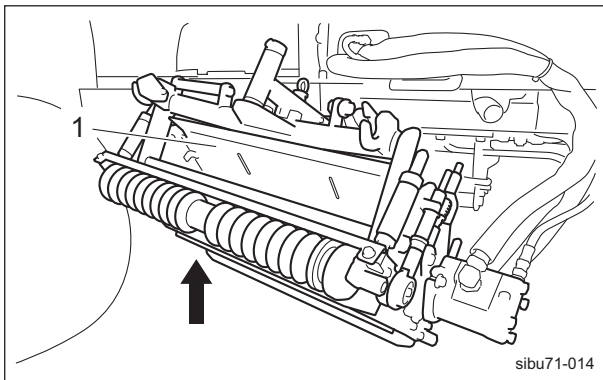

Swiveling Mower Units #2 and #3_005

1	Mower unit
---	------------

6. After the maintenance is completed, reverse the procedure to return the machine to its original condition.

Removing/Installing Tires

Front Tires

Follow the steps below to remove the front tires:

1. Loosen the bolts.

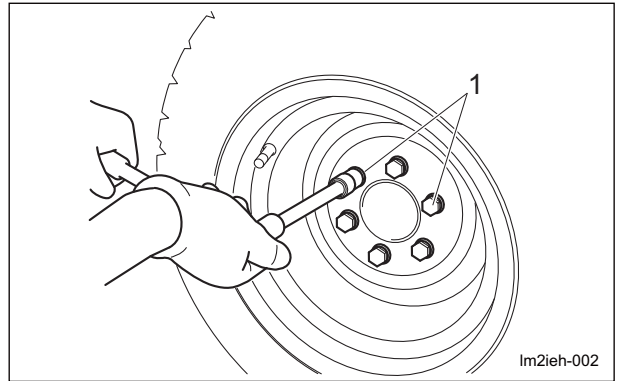

Front Tires_001

1	Heat-treated bolt
---	-------------------

2. Securely place the jack beneath the jack-up point of the front left/right frame area, and then raise it until the tire lifts off the ground. "Jack-up Points" (Page 5-18)

3. Remove the bolts.

4. Remove the tire from the wheel mounting seat.

Important

Tighten the bolts in the tightening order (diagonally).

For installing the front tires, reverse the removing procedure.

Rear Tire

Follow the steps below to remove the rear tire.

1. Loosen the bolts.

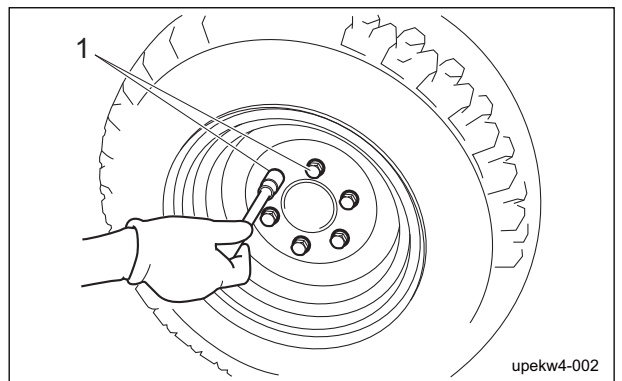

Rear Tire_001

Maintenance

1	Bolt, heat-treated
---	--------------------

- Securely place the jack beneath the jack-up point of the pivot, and then raise it until the tires lift off the ground.
"Jack-up Points" (Page 5-18)
- Remove the bolts.
- Remove the tire from the wheel mounting base.

Important

Tighten the bolts in the tightening order (diagonally).

For installing the rear tire, reverse the removing procedure.

Adjustment of Belt Tension

Warning

Be sure to stop the engine before adjusting the belts.

Important

Before making sure of belt tension, rotate the belt several times.

If the belt becomes slack due to frequent use, it may jump or slip.
In addition, if it is overtightened, it may wear prematurely.
If necessary, adjust it, and always check the belt for appropriate tension.

Fan Belt

- Press the middle of the belt with your finger to check the belt tension.
- If the belt tension is incorrect, loosen bolt A and bolt B (securing the alternator), and then move the alternator to adjust the tension.

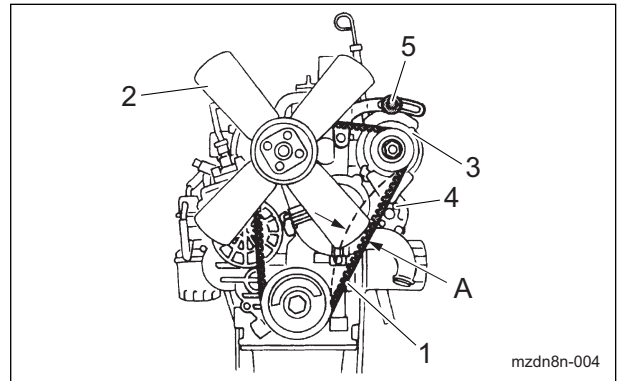

Fan Belt_001

1	Fan Belt
2	Blade
3	Alternator
4	Bolt A
5	Bolt B
A	10 mm (0.39 in)

Adjustment of Parking Brake

Caution

Make sure that the brake wire is not cracked or damaged.

Important

Make sure that the brake is effective on slopes and that it is not applied any longer when you release it.
Adjust the parking brake whenever there is any abnormality.

- Stop the engine.
- Remove the step cover.
- Follow the steps below to adjust the parking brake.
[1] Depress the locking pedal while firmly depressing the brake pedal to lock it and engage the latch in a notch.

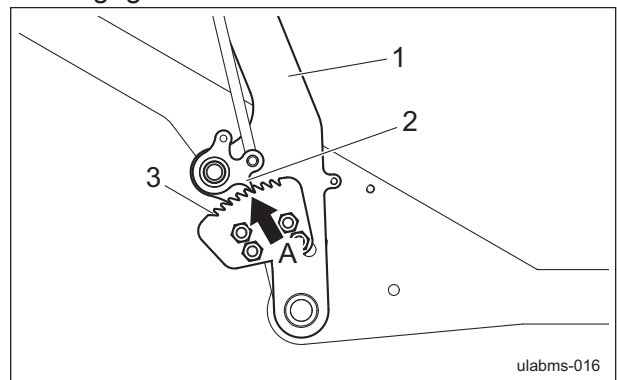

Adjustment of Parking Brake_001

1	Brake pedal
2	Latch
3	Notch
A	Fourth or fifth notch

[2] Adjust the adjustment bolt so that the latch is positioned in the fourth or fifth notch from the top.

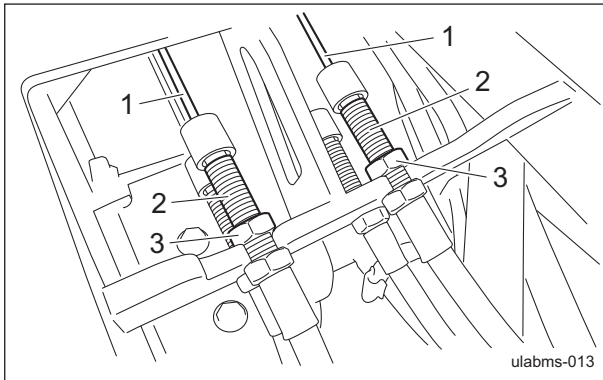

Adjustment of Parking Brake_002

1	Brake wire
2	Adjustment bolt
3	Lock nut

Adjustment of Brake

⚠ Caution

If the brake wire is cut, the machine will be unable to stop.
 If the brake wire is cracked or damaged, immediately replace it with a new one.
 If the brake is not sufficiently effective, adjust the brake wire.

Important

Adjust the play of the brake pedal so that it is as small as possible and the brakes do not drag when released.

Adjust the brake by using the adjustment bolt on the brake wire.

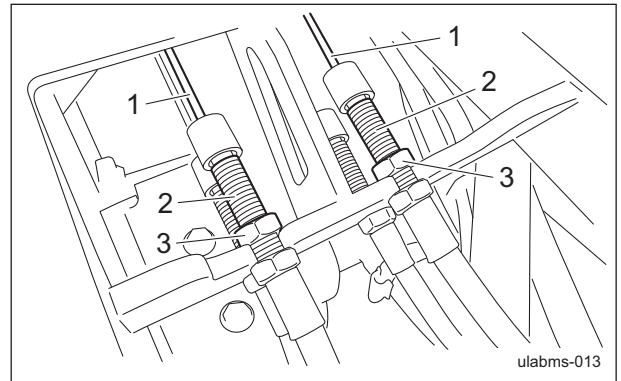

Adjustment of Brake_001

1	Brake wire
2	Adjustment bolt
3	Lock nut

1. Stop the engine.
2. Remove the step cover.

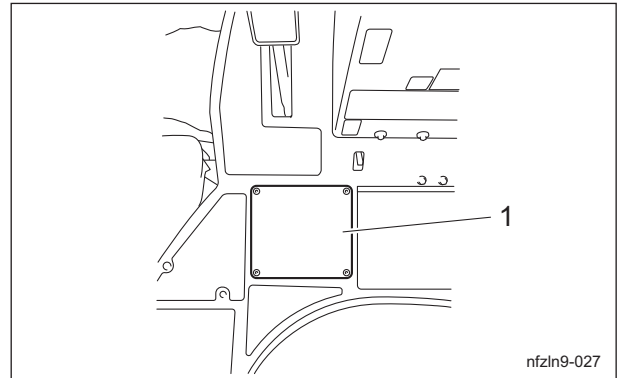

Adjustment of Brake_002

1	Step cover
---	------------

3. Adjust the travel of the brake pedal by tightening the brake wire adjustment bolt.
 - If the brake pedal play is too large, the braking power will be decreased and the pedaling will be light.
 - If the brake pedal play is too small, the braking power will be increased and the pedaling will be heavy.

Maintenance

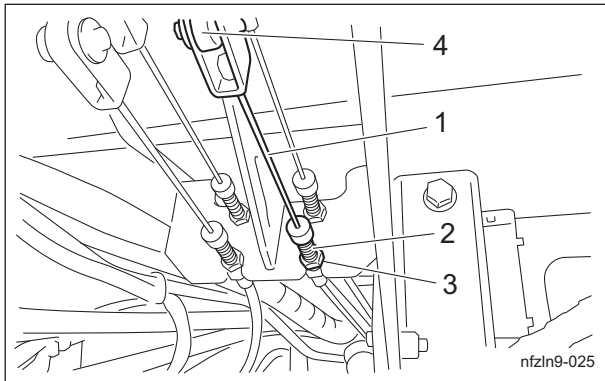

Adjustment of Brake_003

1	Brake wire
2	Adjustment bolt
3	Lock nut
4	Brake pedal

4. Start the engine.
5. Drive the machine to check the following.
 - Make sure that heat is not generated in the brake area.
 - Make sure that the left and right brakes are equally effective.

⚠ Caution

If the left and right brakes are not equally effective, an unexpected accident may occur.

6. If the left and right brakes are not equally effective, make fine adjustments by using the adjustment bolts on the brake wires.

Break-In of Brakes

If the brake shoes or brake pads are worn, replace them with new ones. Immediately after replacement, drive to break in the brakes if the effectiveness of the brakes is low. While driving, lightly operate the brakes to break in the contact areas.

Adjusting The Neutral Position of The Piston Pump

⚠ Caution

Make sure not to touch rotating tires.

⚠ Caution

While adjusting the neutral position, the machine may start to move. Securely place jacks beneath the jack-up points, and then raise the machine until all tires lift off the ground.

If the machine moves forward or backward while the traveling pedals are released, they are not set to the neutral position.

Follow the steps below to make adjustments.

1. Stop the engine.
 2. Securely place jacks beneath the jack-up points, and then lift the machine off the ground. "Jack-up Points" (Page 5-18)
 3. Make sure that no tires get contact with the jack stand.
 4. Open the underseat cover.
 5. Start the engine, and rev it up to the maximum rpm.
 6. Adjust the neutral position.
- Note:
The lock nut uses a 1/2 inch wrench, and the traction adjusting cam uses a 1/4 inch wrench.
Follow the steps below to adjust the neutral position.

[1] Loosen the lock nuts.

[2] Slowly rotate the traction adjusting cam until all tires stop.

- If the tires move in the direction of forward travel, rotate the traction adjusting cam clockwise.
- If the tires move in the direction of backward travel, rotate the traction adjusting cam counterclockwise.

Find the position where all tires stop, and then, while holding the traction adjusting cam in place, secure it with the lock nut.

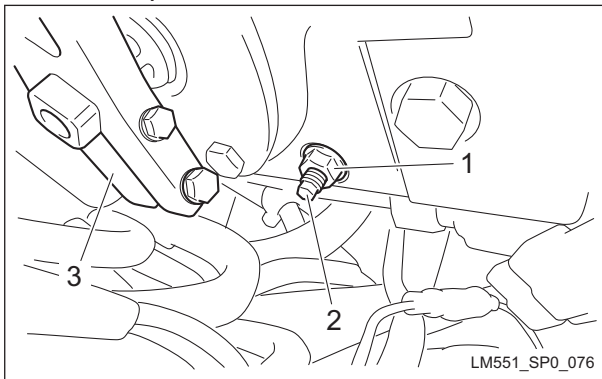

Adjusting The Neutral Position of The Piston Pump_001

1	Lock nut
2	Traction adjusting cam
3	Cam lever

7. Check that the tires do not move.

Adjustment of Control Arm

The control arm can be adjusted up or down and forward or backward.

Adjust the position to fit the operator.

1. Loosen the nut.
2. Slide the control arm up or down and forward or backward to the appropriate position.
3. Tighten the nut.

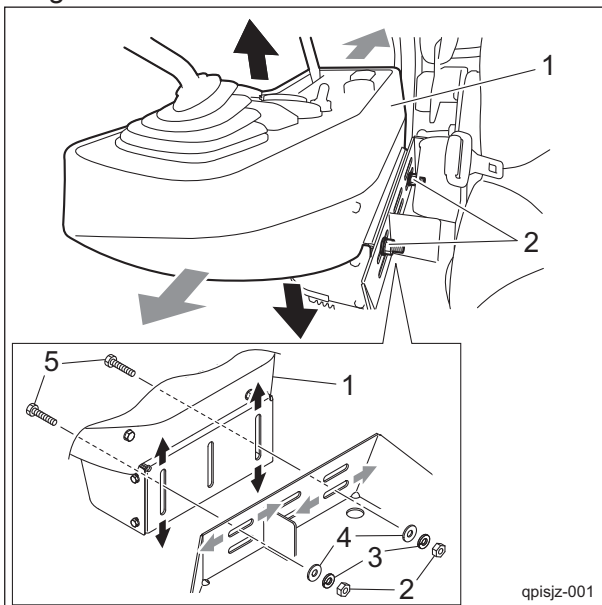

Adjustment of Control Arm_001

1	Control arm
2	Nut
3	Spring washer
4	Washer
5	Bolt

Adjustment of Stoppers

Important

The installation method and installation position of the stoppers differ depending on the mower unit model.

The stopper is installed to prevent the mower arm from interfering with the frame when swiveling the mower units #2 and #3.

Install in the appropriate position.

Note:

The stopper is not used when the mower units LS66 installed.

The stopper installation position for each mower unit model is described below.

A: Installed at the lower position

- LS62
- LH52

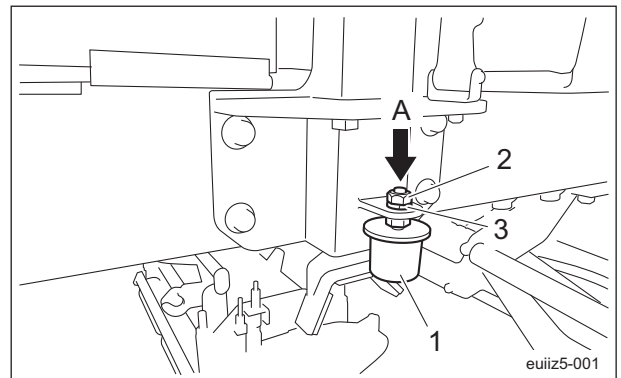

Adjustment of Stoppers_001

1	Stopper
2	Nut
3	Spring washer

Maintenance

B: Installed at the upper position
 · LH62

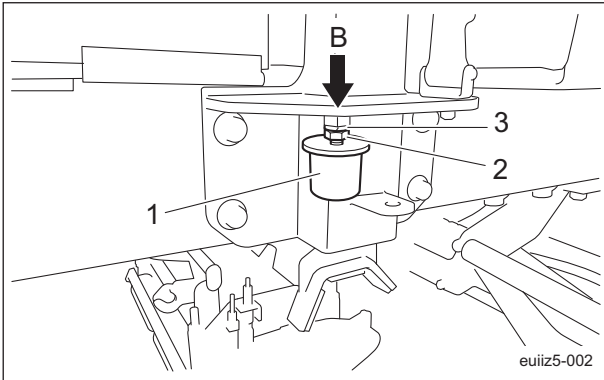

Adjustment of Stoppers_002

1	Stopper
2	Nut
3	Spring washer

Mower unit #2

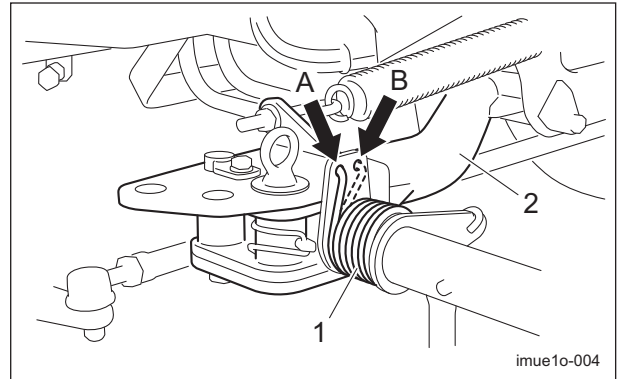

Adjustment of Mower Unit Leveling Spring_002

1	Coil spring
2	Lift arm
A	22 in mower unit
B	26 in mower unit

Adjustment of Mower Unit Leveling Spring

A coil spring is installed on the mower unit coupling. This keeps the mower unit level. Adjust the coil spring with the holes in the lift arm.

Mower unit #1

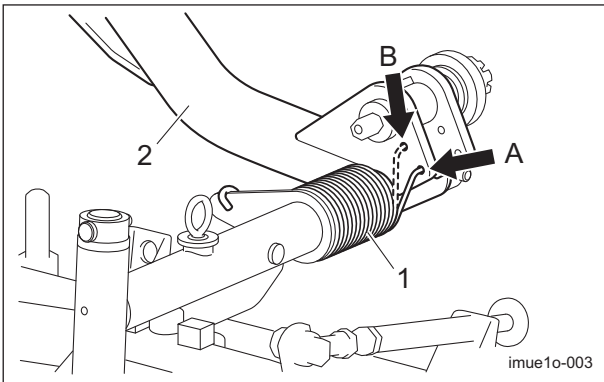

Adjustment of Mower Unit Leveling Spring_001

1	Coil spring
2	Lift arm
A	22 in mower unit
B	26 in mower unit

Mower unit #3

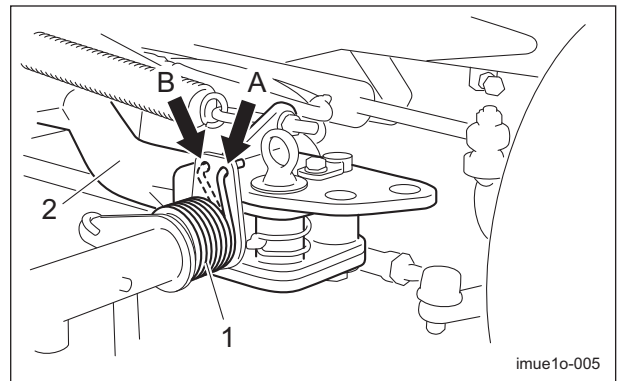

Adjustment of Mower Unit Leveling Spring_003

1	Coil spring
2	Lift arm
A	22 in mower unit
B	26 in mower unit

Mower unit #4
 22 in mower unit

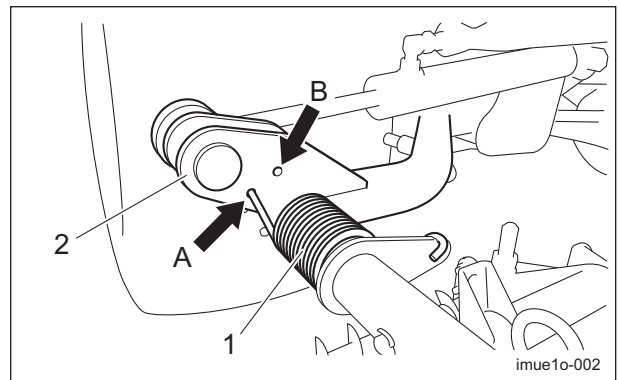

Adjustment of Mower Unit Leveling Spring_004

1	Coil spring
2	Lift arm
A	Light spring load (standard position)
B	Heavy spring load

26 in mower unit

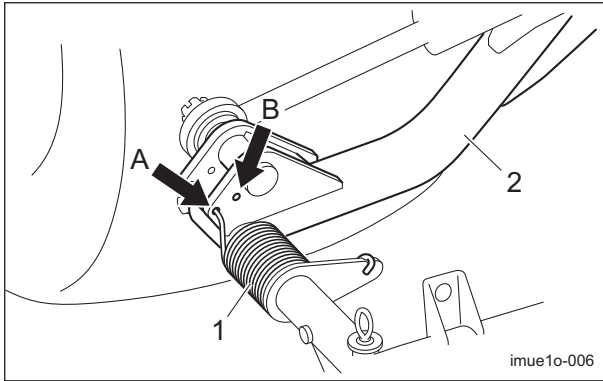

Adjustment of Mower Unit Leveling Spring_005

1	Coil spring
2	Lift arm
A	Light spring load (standard position)
B	Heavy spring load

Mower unit #5

22 in mower unit

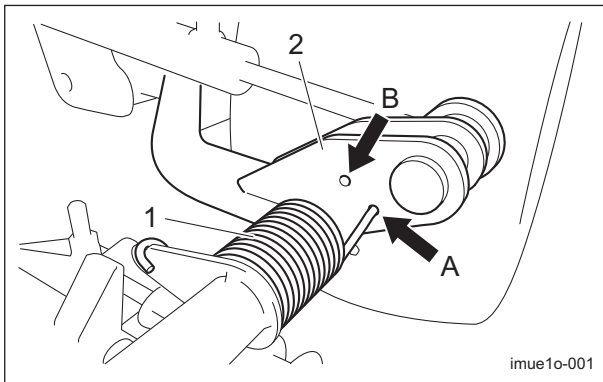

Adjustment of Mower Unit Leveling Spring_006

1	Coil spring
2	Lift arm
A	Light spring load (standard position)
B	Heavy spring load

26 in mower unit

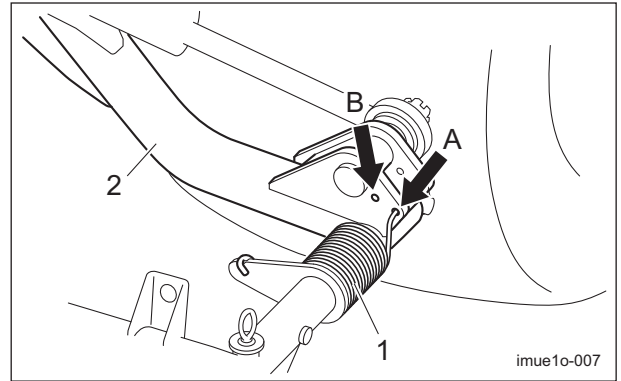

Adjustment of Mower Unit Leveling Spring_007

1	Coil spring
2	Lift arm
A	Light spring load (standard position)
B	Heavy spring load

Adjustment of Positions of Mower Units #2 and #3

Important

When the grass catcher is installed, move the mower units to the rear position.

Mower units #2 and #3 can be slid to the front position or rear position. The slide distance is 200 mm (7.87 in).

1. On a level surface, lower all mower units.
2. Move the mower unit up/down lever to the neutral position.
3. Depress the locking pedal while firmly depressing the brake pedal to lock it.
4. Stop the engine.
5. Remove the clamps from the mower unit up/down cylinder hoses.

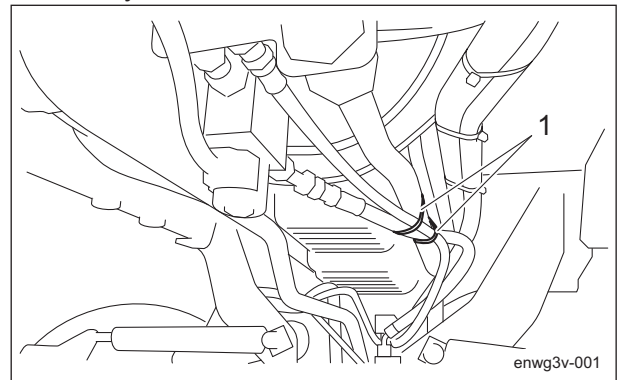

Adjustment of Positions of Mower Units #2 and #3_001

1	Clamp
---	-------

Maintenance

Important

Since mower units #2 and #3 are connected, slide them at the same time.

6. Follow the steps below to slide the mower units.

· When moving to the front position:

- [1] Loosen bolt A of mower unit #3.
- [2] Remove bolts B of mower unit #3.

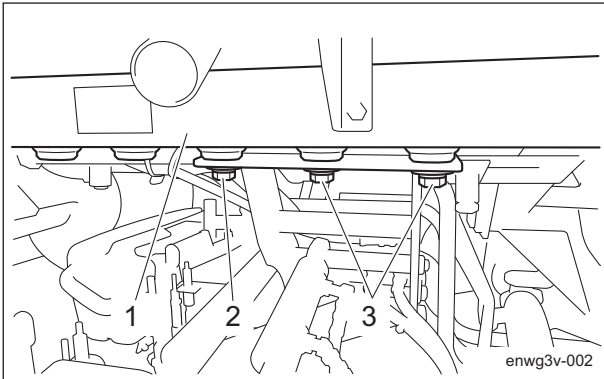

Adjustment of Positions of Mower Units #2 and #3_002

1	Frame
2	Bolt A
3	Bolt B

[3] In the same way, loosen bolt A and remove bolts B of mower unit #2.

[4] Slide mower units #2 and #3 from the rear position to the front position.

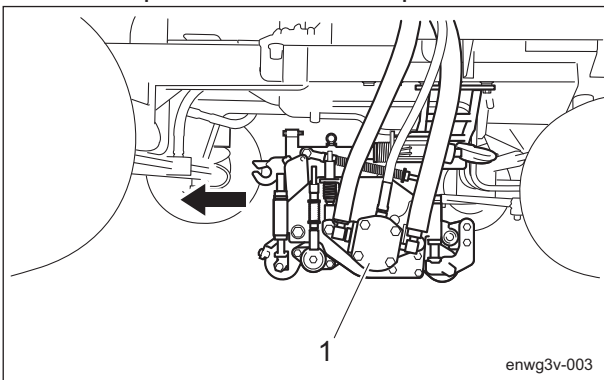

Adjustment of Positions of Mower Units #2 and #3_003

1	Mower unit
---	------------

[5] Install bolts B of mower unit #3.

[6] In the same way, install bolts B of mower unit #2.

[7] Tighten bolt A and bolts B on both sides.

· When moving to the rear position:

- [1] Loosen bolt A of mower unit #3.

[2] Remove bolts B of mower unit #3.

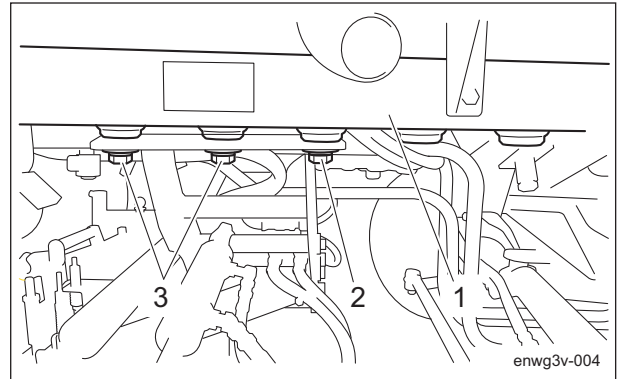

Adjustment of Positions of Mower Units #2 and #3_004

1	Frame
2	Bolt A
3	Bolt B

[3] In the same way, loosen bolt A and remove bolts B of mower unit #2.

[4] Slide mower units #2 and #3 from the front position to the rear position.

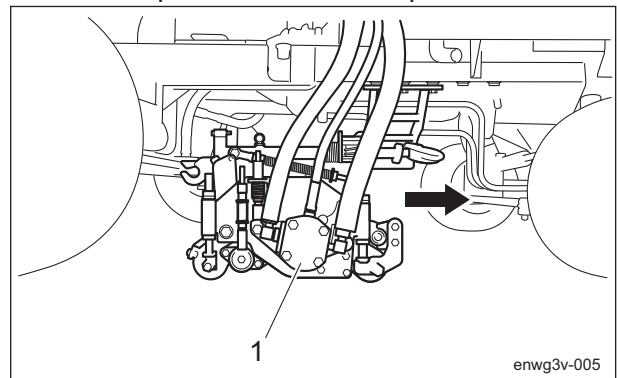

Adjustment of Positions of Mower Units #2 and #3_005

1	Mower unit
---	------------

[5] Install bolts B of mower unit #3.

[6] In the same way, install bolts B of mower unit #2.

[7] Tighten bolt A and bolts B on both sides.

7. Adjust the mower stoppers of mower units #2 and #3.

"Adjustment of Mower Stoppers for Mower Unit #2 and #3" (Page 5-35)

8. Re-secure the mower unit up/down cylinder hoses with clamps.

Adjustment of Mower Stopper

Adjustment of Mower Stoppers for Mower Unit #1

The mower stopper is installed to prevent the mower unit from interfering with the frame.

The attaching direction of the mower stopper for mower unit #1 differs according to the type of mower unit.

Install in the appropriate direction.

1. Loosen the nuts of the right and left mower stoppers.
2. Place the right and left mower stoppers to the highest position and attach them temporarily.
3. On a level surface, raise all mower units.
4. Depress the locking pedal while firmly depressing the brake pedal to lock it.
5. Stop the engine.
6. Follow the steps below to adjust the position of the mower stopper.

[1] Loosen the nuts of the right and left mower stoppers.

[2] Tighten the nuts of the right and left mower stoppers in a position where the mower unit is leveled and the mower arm contacts the center of the mower stopper.

LH62

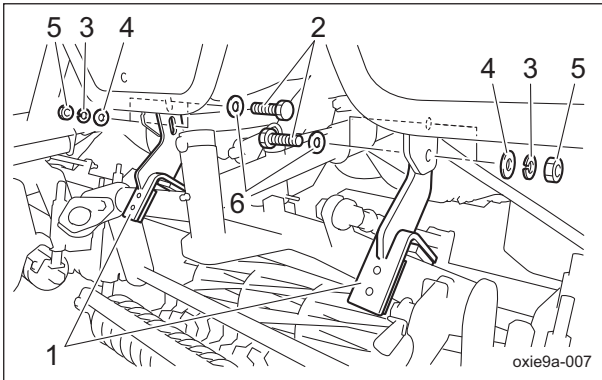

Adjustment of Mower Stoppers for Mower Unit #1_001

1	Mower stopper
2	Bolt
3	Spring washer
4	Washer
5	Nut
6	Washer

LH52 · LS62 · LS66

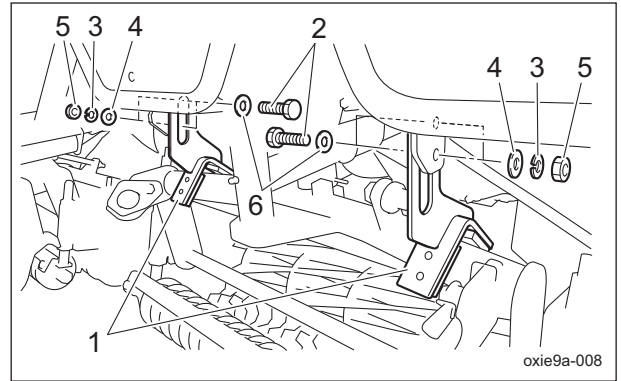

Adjustment of Mower Stoppers for Mower Unit #1_002

1	Mower stopper
2	Bolt
3	Spring washer
4	Washer
5	Nut
6	Washer

Adjustment of Mower Stoppers for Mower Unit #2 and #3

The mower stopper is installed to prevent the mower unit from interfering with the frame. The type and attaching direction of the mower stopper for mower unit #2 and #3 differ according to the type of mower unit. And adjust the attaching position of the mower stopper for mower unit #2 and #3 according to the attaching position (front or rear) of the mower unit.

Install in the appropriate direction.

1. On a level surface, lower all mower units.
2. Depress the locking pedal while firmly depressing the brake pedal to lock it.
3. Stop the engine.
4. Open the hood.
5. Open the underseat cover.

Maintenance

6. Remove the nuts of the mower stopper.

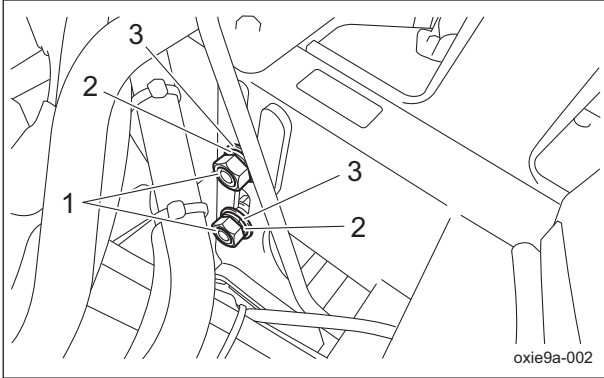

Adjustment of Mower Stoppers for Mower Unit #2 and #3_001

1	Nut
2	Spring washer
3	Washer

7. Adjust the mower stopper position.

- To set the mower unit in the front position, attach the mower stopper in the "front position".
- To set the mower unit in the rear position, attach the mower stopper in the "rear position".

Mower unit #2

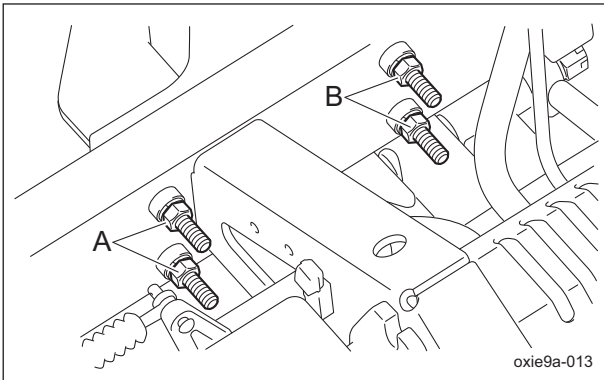

Adjustment of Mower Stoppers for Mower Unit #2 and #3_002

A	Mower stopper front position
B	Mower stopper rear position

Mower unit #3

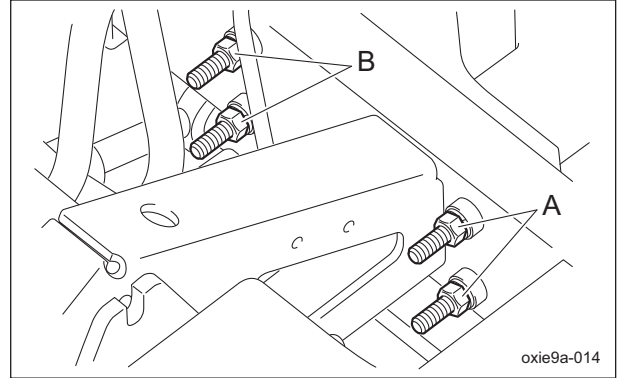

Adjustment of Mower Stoppers for Mower Unit #2 and #3_003

A	Mower stopper front position
B	Mower stopper rear position

8. Attach the mower stoppers temporarily.
9. Start the engine.
10. Raise all mower units.
11. Tighten the mower stopper nuts previously attached in a position where the mower unit is leveled and the mower stopper contacts the mower arm.

Note:

The relationship between the mower unit type and the mower stopper is as follows.

LH62

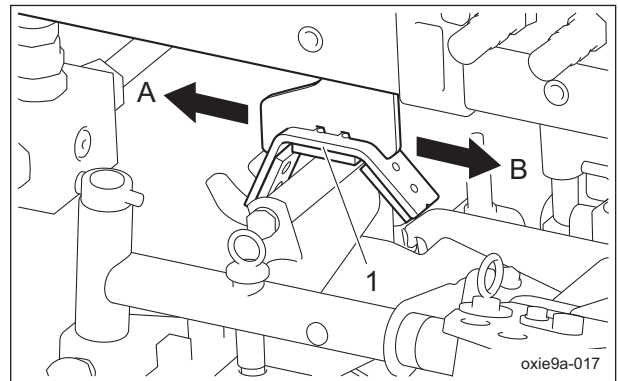

Adjustment of Mower Stoppers for Mower Unit #2 and #3_004

1	Mower stopper
A	Front
B	Rear

LH52 · LS62

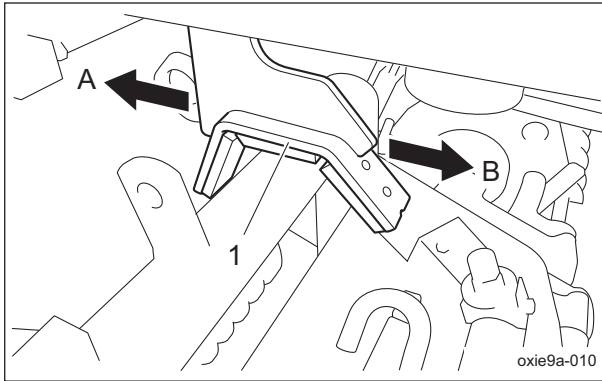

Adjustment of Mower Stoppers for Mower Unit #2 and #3_005

1	Mower stopper
A	Front
B	Rear

LS66

Mower unit #2

After installing the mower stoppers, press the stopper auxiliary fitting COMP firmly against the bottom side of the frame and secure it with the bolts.

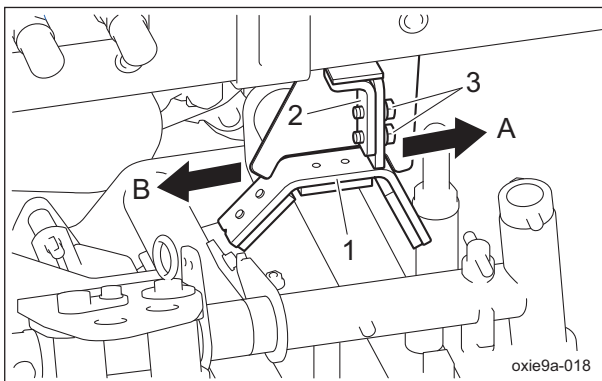

Adjustment of Mower Stoppers for Mower Unit #2 and #3_006

1	Mower stopper
2	Stopper auxiliary fitting COMP
3	Bolt
A	Front
B	Rear

LS66

Mower unit #3

After installing the mower stoppers, press the stopper auxiliary fitting COMP firmly against the bottom side of the frame and secure it with the bolts.

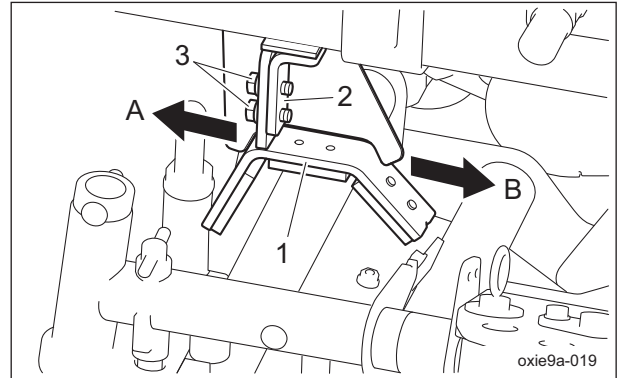

Adjustment of Mower Stoppers for Mower Unit #2 and #3_007

1	Mower stopper
2	Stopper auxiliary fitting COMP
3	Bolt
A	Front
B	Rear

Adjustment of Mower Stoppers for Mower Unit #4 and #5

The mower stopper is installed to prevent the mower unit from interfering with the frame. The attaching position of the mower stopper for mower unit #4 and #5 differs according to the type of mower unit. Install in the appropriate direction. The relationship between the mower unit type and the mower stopper attaching position.

LH62

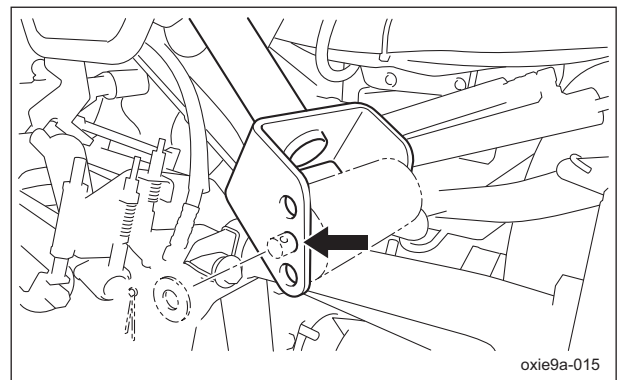

Adjustment of Mower Stoppers for Mower Unit #4 and #5_001

Maintenance

LH52 • LS62

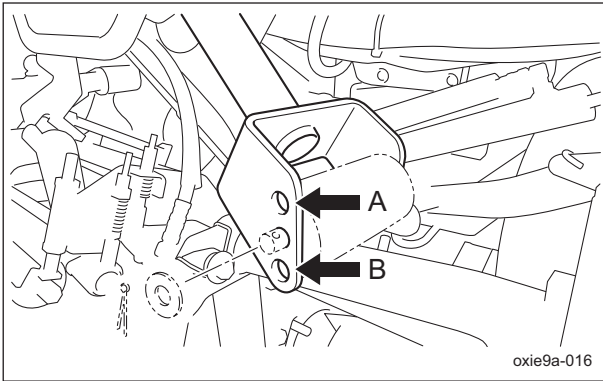

Adjustment of Mower Stoppers for Mower Unit #4 and #5_002

A	LS62
B	LH52

1. On a level surface, lower all mower units.
2. Depress the locking pedal while firmly depressing the brake pedal to lock it.
3. Stop the engine.
4. Follow the steps below to adjust the mower stopper position.

[1] Remove the cotter pin and washer.

[2] Install the roller shaft and rubber roller in the specified position.

[3] Attach the cotter pin and washer.

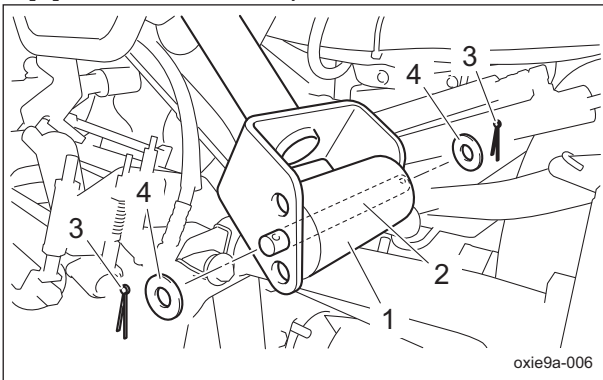

Adjustment of Mower Stoppers for Mower Unit #4 and #5_003

1	Rubber roller
2	Roller shaft
3	Cotter pin
4	Washer

LS66

For the mower unit LS66, the adjustment is not required.

Change of Coolant

⚠ Caution

Do not touch the radiator or coolant during engine operation or immediately after the engine has been turned off. Otherwise, you may get burned.

⚠ Caution

Change coolant after the engine has well cooled down.

⚠ Caution

The radiator cap is pressurized. If you remove the radiator cap while the engine is overheated, hot steam will burst out, possibly resulting in burns. Make sure that the water temperature and pressure are reduced, and then grab the cap with a thick cloth and gradually open the cap.

Important

When changing the coolant, be sure to drain it into a container and discard it in accordance with local laws and regulations.

Important

When changing the coolant, be sure to mix clean water (soft water) and antifreeze (long-life coolant), and then pour it into the radiator and reserve tank.

Important

Tightly close the radiator cap. If the cap is loose or incorrectly installed, water may leak and the engine may overheat.

When mixing antifreeze and clean water (soft water), refer to "Relationship between concentration of long-life coolant (LLC) and freezing temperature" below for the mixing ratio.

Relationship between concentration of long-life coolant (LLC) and freezing temperature

Freezing temperature	LLC concentration (volume %)
Down to -10 °C (14 °F)	20 %
Down to -15 °C (5 °F)	30 %
Down to -20 °C (-4 °F)	35 %
Down to -25 °C (-13 °F)	40 %

1. Stop the engine, and then allow the radiator to cool.
2. Open the hood.
3. Follow the steps below to drain the coolant.

[1] Position a container to drain the coolant into.

[2] Remove the drain plug from the radiator.

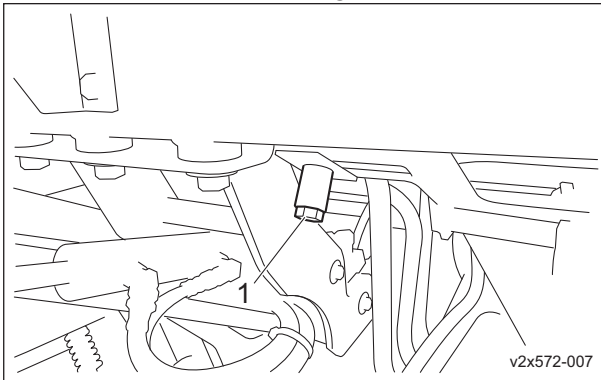

Change of Coolant_001

1	Radiator drain plug
---	---------------------

[3] Remove the radiator cap.

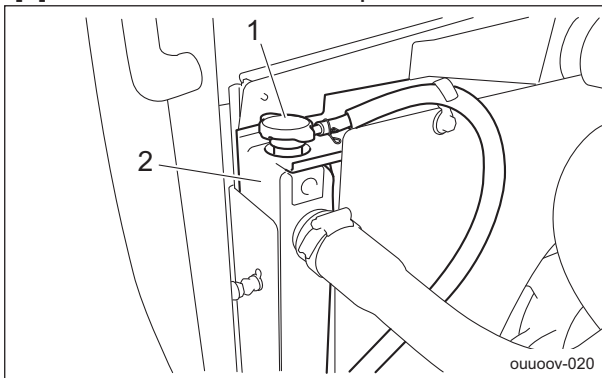

Change of Coolant_002

1	Radiator cap
2	Radiator

[4] Remove the reserve tank.

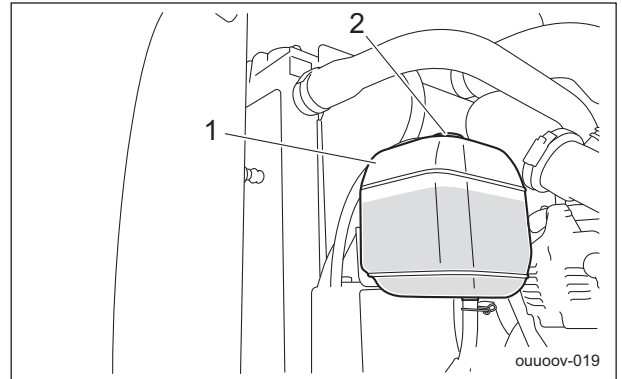

Change of Coolant_003

1	Reserve tank
2	Reserve tank cap

[5] Open the reserve tank cap, and then drain the coolant.

4. Install the reserve tank.
5. Clean the radiator with clean water (soft water) to remove any debris or rust.
6. Drain all water from the radiator.
7. Follow the steps below to fill with coolant. The coolant quantity, including the reserve tank, is 10.0 dm³ (10.0 L).

[1] Install the drain plug.

[2] Supply clean water (soft water) and antifreeze into the radiator up to the radiator cap opening.

[3] Close the radiator cap.

[4] Supply clean water (soft water) and antifreeze into the reserve tank up to the "FULL" mark.

[5] Close the reserve tank cap.

8. Start the engine, and then idle for several minutes to bleed air from the system.
9. Stop the engine, and then allow the radiator to cool.
10. Check if the coolant level in the reserve tank is between "FULL" and "LOW", and then supply coolant if necessary.
11. Close the hood.

Maintenance

Change of Hydraulic Oil

⚠ Caution

Be careful with hot oil, which could cause burns if it contacts your skin.

Important

When you change the hydraulic oil, be sure to drain it into a container and discard it in accordance with local laws and regulations.

Important

If the hydraulic oil emulsifies or if it becomes even slightly less transparent, change the oil immediately.

Important

Use Shell Tellus S2M46 (or equivalent) as hydraulic oil.

1. Follow the steps below to remove the old oil.

- [1] Start and run the engine to warm up the oil.
- [2] On a level surface, lower the mower units, and then stop the engine.
- [3] Remove the drain plug of the hydraulic tank and drain the old oil into a bowl.
- [4] Install the drain plug.

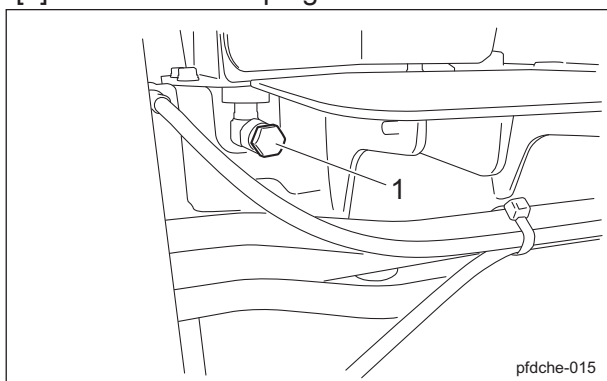

Change of Hydraulic Oil_001

1	Drain plug
---	------------

2. Remove the tank cover.

3. Open the tank cap, and then pour new oil from the fill port until the oil level reaches the middle of the oil gauge on the hydraulic tank. The hydraulic tank capacity is approximately 30.3 dm³ (30.3 L).

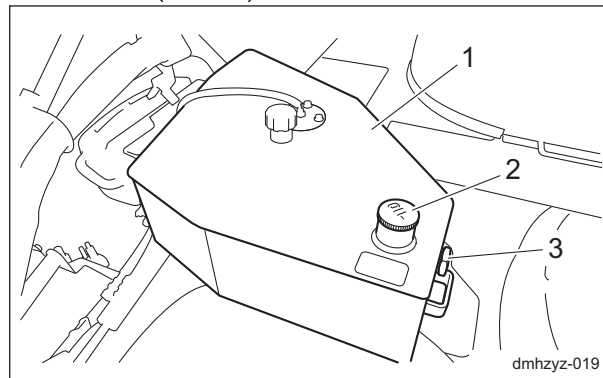

Change of Hydraulic Oil_002

1	Hydraulic tank
2	Tank cap
3	Oil gauge

4. Tighten the tank cap securely.
5. Start the engine, raise and lower the mower units, and turn the steering wheel left and right. Move forward and reverse repeatedly several times.
6. Raise the mower units and maintain that position on a level surface, and then check to see if the oil level is at the middle of the oil gauge. If necessary, supply oil.
7. Check underneath the machine for hydraulic oil leakage.
8. Install the tank cover.

Change of Hydraulic Oil Filter

Change of Hydraulic Oil Line Filter

Caution

Be careful with hot oil, which could cause burns if it contacts your skin.

Important

When replacing the hydraulic oil filter, be sure to drain the oil into a container and discard it in accordance with local laws and regulations.

Important

If the hydraulic oil emulsifies or if it becomes even slightly less transparent, change the oil immediately.

Important

Use Shell Tellus S2M46 (or equivalent) as hydraulic oil.

1. On a level surface, lower the mower units, and then stop the engine.
2. Loosen the filter case and remove it.
Note:
 Use a 24 mm socket wrench.

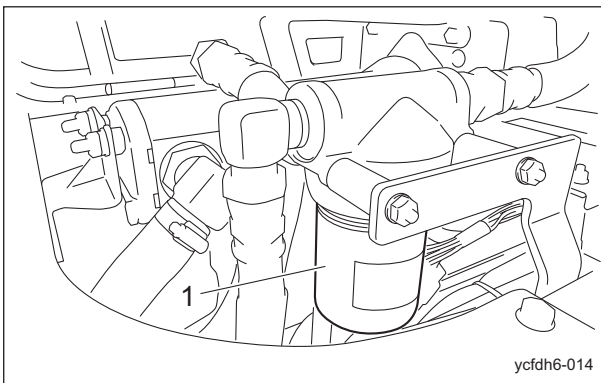

Change of Hydraulic Oil Line Filter_001

1	Filter case
---	-------------

3. Remove the old filter cartridge.

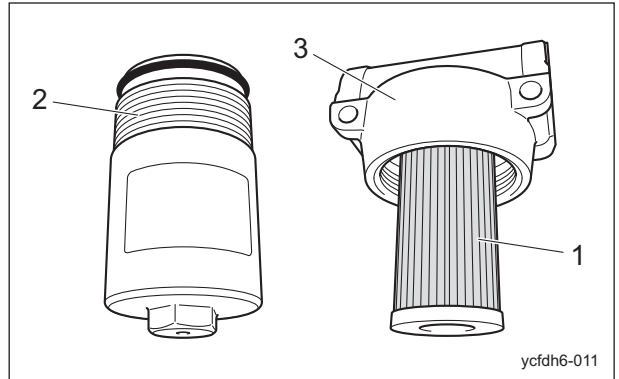

Change of Hydraulic Oil Line Filter_002

1	Filter cartridge
2	Filter case
3	Body

4. Lightly coat the O-ring of the new filter cartridge with hydraulic oil, and then install the cartridge.

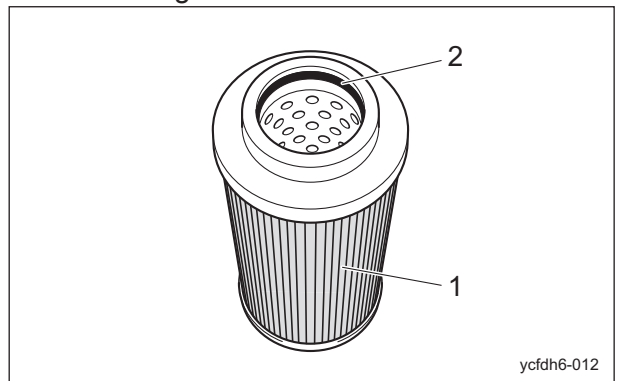

Change of Hydraulic Oil Line Filter_003

1	Filter cartridge
2	O-ring

5. Clean the inside of the filter case.
6. Make sure that there is no damage to the O-ring of the filter case, and then lightly coat the O-ring with hydraulic oil.

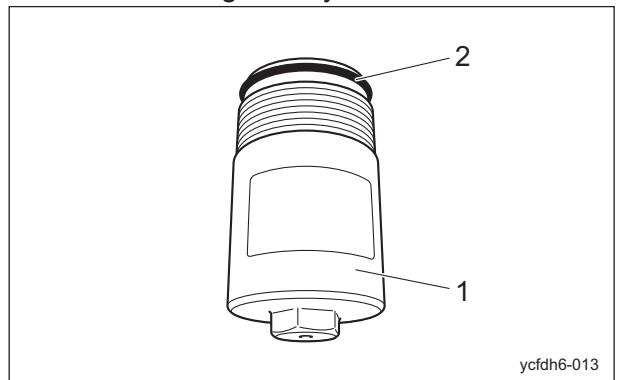

Change of Hydraulic Oil Line Filter_004

Maintenance

1	Filter case
2	O-ring

7. Install the filter case onto the body, firmly hand-tighten it, and then tighten it to 25 to 35 N·m (254.93 to 356.90 kgf·cm).

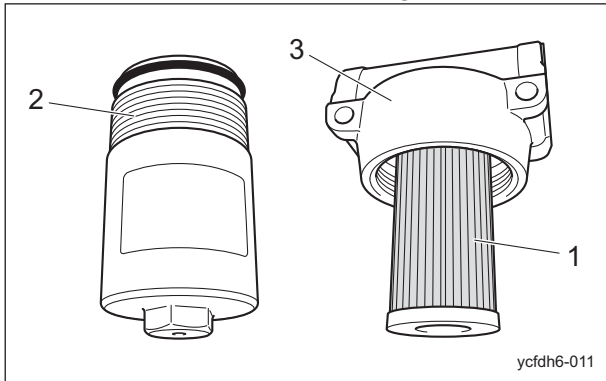

Change of Hydraulic Oil Line Filter_005

1	Filter cartridge
2	Filter case
3	Body

8. Supply hydraulic oil until it reaches the specified level.
"Supply of Hydraulic Oil" (Page 4-5)
9. Start the engine, and then after the hydraulic oil has warmed up, stop the engine.
10. Check underneath the machine for hydraulic oil leakage.

Replacement of Hydraulic Suction Filter

Caution

Be careful with hot oil, which could cause burns if it contacts your skin.

Important

When replacing the hydraulic oil filter, be sure to drain the oil into a container and discard it in accordance with local laws and regulations.

Important

If the hydraulic oil emulsifies or if it becomes even slightly less transparent, change the oil immediately.

Important

Use Shell Tellus S2M46 (or equivalent) as hydraulic oil.

1. On a level surface, lower the mower units, and then stop the engine.
2. Remove the filter protection plate.

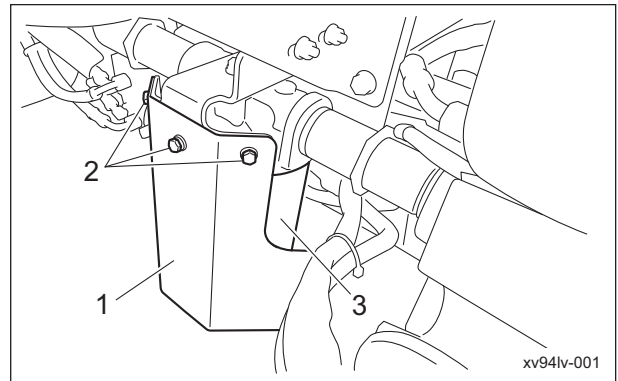

Replacement of Hydraulic Suction Filter_001

1	Filter protection plate
2	Bolt
3	Filter cartridge

3. Remove the old filter cartridge.
4. Lightly coat the packing of the new filter cartridge with hydraulic oil, and then install the cartridge.
5. Firmly tighten the filter cartridge by hand so that the packing contacts the mounting surface.
Then, tighten it an additional 1/2 turn.

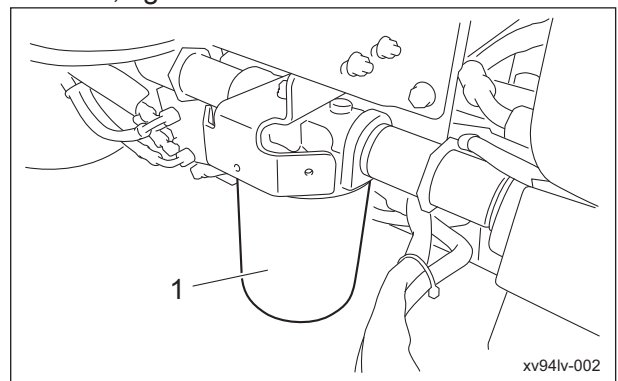

Replacement of Hydraulic Suction Filter_002

1	Cartridge filter
---	------------------

6. Supply hydraulic oil until it reaches the specified level.
"Supply of Hydraulic Oil" (Page 4-5)
7. Start the engine, and then after the hydraulic oil has warmed up, stop the engine.

8. Check underneath the machine for hydraulic oil leakage.
9. Install the filter protection plate.

Change of Air Cleaner

A contaminated air cleaner element may cause malfunction of the engine.

To maximize the life of the engine, replace the air cleaner element at the appropriate times.

1. The timing for replacing the air cleaner element is described below.
 - [1] Replace the air cleaner element in accordance with the Maintenance Schedule.
 - [2] If it is significantly contaminated, replace it, even if the hours of operation do not exceed the specified time.
2. Replace the air cleaner element by following the same steps as for cleaning the air cleaner.

"Cleaning of Air Cleaner" (Page 4-6)

Change of Engine Oil

⚠ Caution

Be careful with hot oil, which could cause burns if it contacts your skin.

Important

When changing the engine oil, be sure to drain it into a container and discard it in accordance with local laws and regulations.

Important

Be sure to use engine oil that is classified as JASO DH-2 or API Service Grade CJ-4, with an SAE Viscosity that is appropriate for the operating environment (ambient temperature).

Important

Securely tighten the oil level gauge and oil filler cap.

Change the engine oil more frequently if it is contaminated and especially if you use the machine in dusty areas or operate the engine at high loads or in high temperatures.

1. Follow the steps below to remove the old engine oil.
 - [1] Start and run the engine to warm up the engine oil.
 - [2] With the machine on a level surface, stop the engine.
 - [3] Remove the drain plug, and then drain the old engine oil into a container.

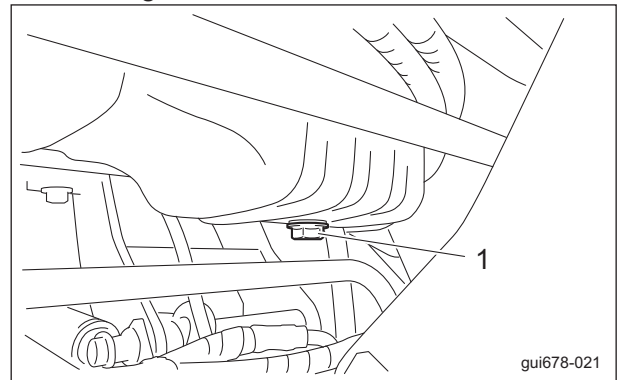

Change of Engine Oil_001

1	Drain plug
---	------------

- [4] Re-place the drain plug.
2. Remove the oil filler cap, and then supply new engine oil until the oil reaches a level in between the upper and lower limit lines on the oil level gauge.

The engine oil quantity is approximately 6.0 dm³ (6.0 L).
3. Securely install the oil filler cap.

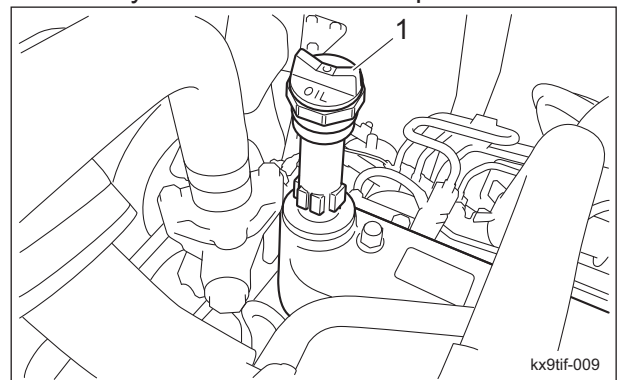

Change of Engine Oil_002

1	Oil filler cap
---	----------------

4. It will take a while for the supplied engine oil to descend into the oil pan.

Check the oil level again 10 to 20 minutes after replenishment.
5. Check underneath the machine for oil leakage.

Maintenance

Change of Engine Oil Filter

⚠ Caution

Be careful with hot oil, which could cause burns if it contacts your skin.

Important

When replacing the engine oil filter, be sure to drain the engine oil into a container and discard it in accordance with local laws and regulations.

Important

Be sure to use engine oil that is classified as JASO DH-2 or API Service Grade CJ-4, with an SAE Viscosity that is appropriate for the operating environment (ambient temperature).

Important

Securely tighten the oil level gauge and oil filler cap.

1. With the filter wrench, remove the old filter cartridge.

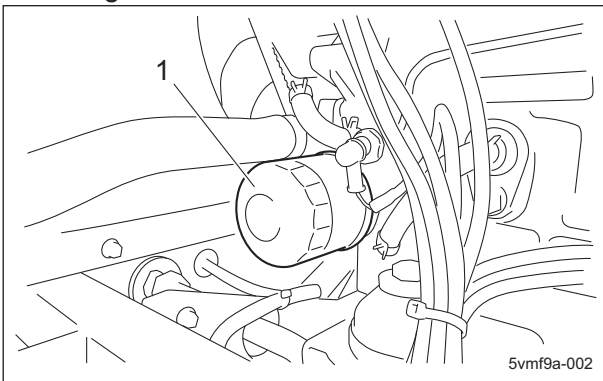

Change of Engine Oil Filter_001

1	Filter cartridge
---	------------------

2. Lightly coat the packing of the new filter cartridge with engine oil.
3. Hand-tighten the filter cartridge until the packing contacts the sealing surface, and then firmly hand-tighten (without using a filter wrench).
4. Supply engine oil until it reaches the specified level.
"Supply of Engine Oil" (Page 4-10)
5. Start the engine, and then stop it after 10 to 20 minutes.

6. Make sure that there is no oil leakage at the sealing surface of the filter cartridge.
7. Check the engine oil level.
If it is low, supply engine oil until it reaches the specified level.

Replacement of Fuel Filter

Important

During installation, prevent contamination with dirt or dust.

If the fuel is contaminated with dirt, dust, etc., the fuel injection pump and injection nozzle will become worn.

Since the fuel filter is a cartridge, it cannot be disassembled or cleaned.
If dust or dirt accumulates in the fuel filter, the fuel flow will become insufficient.
Replace the fuel filter at the appropriate times.

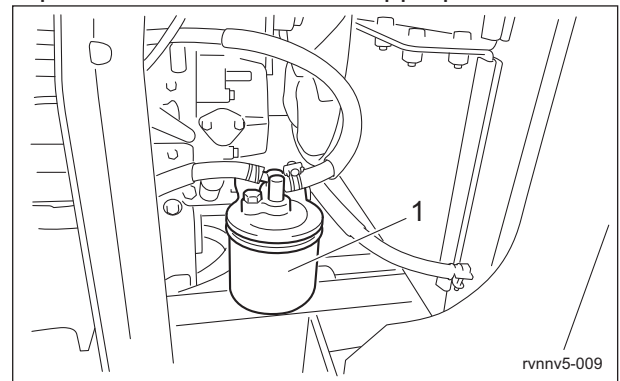

Replacement of Fuel Filter_001

1	Fuel filter
---	-------------

1. Follow the steps below to replace the fuel filter.
 - [1] Using a filter wrench, remove the fuel filter cartridge.
 - [2] Lightly coat the packing of the new cartridge with fuel, and then firmly hand-tighten the cartridge, without using the filter wrench.

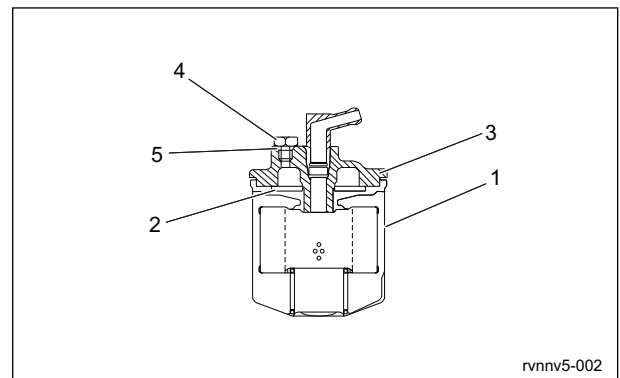

rvnnv5-002

Replacement of Fuel Filter_002

1	Cartridge
2	Packing
3	Cover
4	Air-bleeding plug
5	O-ring

2. When the key switch is turned to the "ON" position and the fuel pump is operated after replacement, air bleeding will occur automatically.

If the automatic air bleeding is not available, remove air manually.

Change of Fuse

Fuse Box

Important

Before performing maintenance on the electrical system, be sure to disconnect the negative terminal of the battery.

Important

If a fuse blows, a short may have occurred within the electrical circuit. Check for the cause, such as faulty terminal connections, damaged wiring or terminals, or incorrect wiring.

The fuse box includes spare fuses and tools.

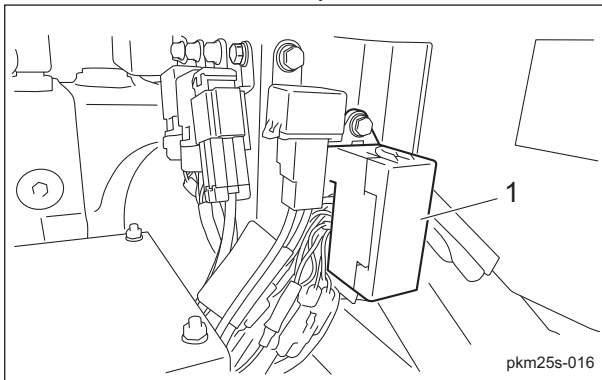

Fuse Box_001

1	Fuse box
---	----------

The machine uses a mini fuse for automobiles. Replace an old fuse with a new fuse of the specified capacity.

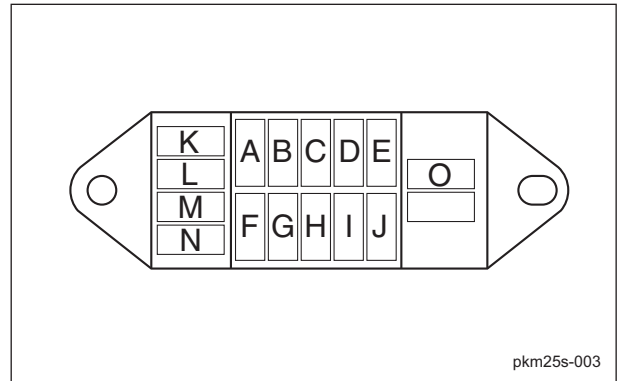

pkm25s-003

Fuse Box_002

A	5 A	Timer unit
B	5 A	Thermo-start lamp
C	5 A	Fuel gauge, water temperature gauge, charge lamp, oil pressure (engine oil pressure), lamp, water temperature buzzer, hydraulic oil buzzer, hour meter
D	15 A	Relay box L, #4 proximity sensor, #5 proximity sensor, proximity sensor (operation lever), proximity sensor (traveling pedal position detection), delay timer (mower units #2 & #3 lowering)
E	15 A	Relay box R, proximity switch, delay timer (seat), #2 proximity sensor, reel forward/reverse switch
F	-	(Unused)
G	5 A	Timer unit
H	5 A	Alternator
I	5 A	Fuel pump, reel rotation switch
J	5 A	Neutral sensor, parking brake sensor
K	5 A	Spare
L	5 A	
M	15 A	
N	15 A	
O		Tool

Maintenance

Fusible Link

Fuse capacities of the fusible links are 30 A, 50 A and 80 A.

- Engine stop solenoid: 30 A
- ECU: 50 A
- Battery: 80 A

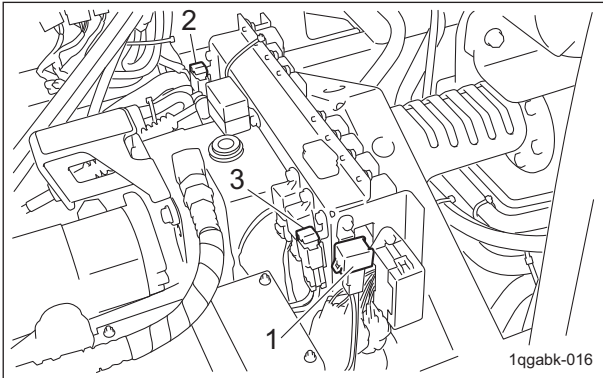

Fusible Link_001

1	Fusible link (30 A)
2	Fusible link (50 A)
3	Fusible link (80 A)

BARONESS[®]
Quality on Demand

 **KYOEISHA CO., LTD.**
Head Office 1-26, Miyuki-cho, Toyokawa-city, Tel :+81-533-84-1390
Aichi-pref, 442-8530 JAPAN Fax:+81-533-84-1220