

LM331

3-Unit Surround & Trim Mower

Owner's Operating Manual

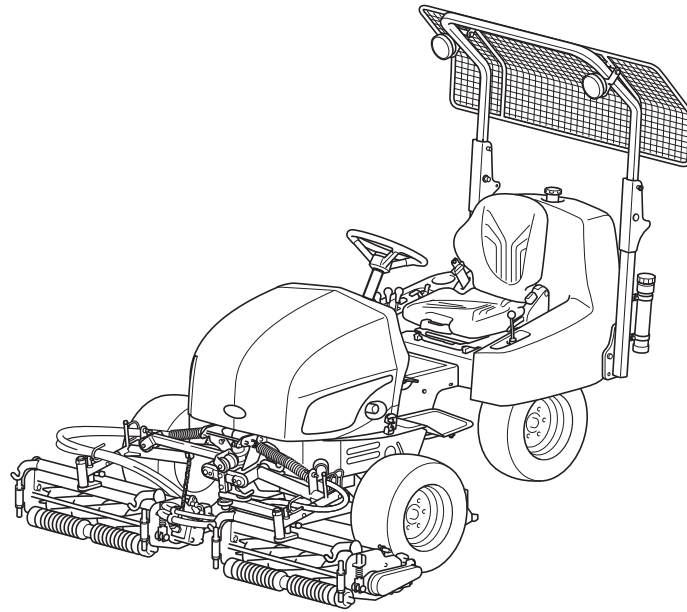

Serial No. LM331 : 10264-

"Required reading"
Read this manual before using the machine.

BARONESS[®]
Quality on Demand

Original Instructions Ver.2.0

Regulations

California Proposition 65

(For California, USA)

WARNING:

Operating, servicing and maintaining a passenger vehicle or off-road vehicle can expose you to chemicals including engine exhaust, carbon monoxide, phthalates, and lead, which are known to the State of California to cause cancer and birth defects or other reproductive harm. To minimize exposure, avoid breathing exhaust, do not idle the engine except as necessary, service your vehicle in a well-ventilated area and wear gloves or wash your hands frequently when servicing your vehicle. For more information go to www.P65Warnings.ca.gov/passenger-vehicle.

318yi8-005

California Proposition 65_001

California Spark Arrester

(For California, USA)

Warning

Operation of this equipment may create sparks that can start fires around dry vegetation.

A spark arrester may be required.

The operator should contact local fire agencies for laws or regulations relating to fire prevention requirements.

It is a violation of California Public Resource Code Section 4442 or 4443 to use or operate the engine on any forest-covered, brush-covered, or grass-covered land unless the engine is equipped with a spark arrester, as defined in Section 4442, maintained in effective working order or the engine is constructed, equipped, and maintained for the prevention of fire pursuant to Section 4443.

The engine of this machine is not equipped with a spark arrester.

In some areas there are local, state, or federal regulations requiring that a spark arrester be used on the engine of this machine.

The recommended spark arrester for this machine is Part No.49025N Spark Arrester made by Nelson Global Products.

Thank you for purchasing the Baroness product. This manual describes the proper handling, adjustment, and inspection of your product. We hope you will use the product safely, and take advantage of its best performance. For details on the handling, adjustment and inspection of the attachments, refer to the Owner's Operating Manual for the attachments.

Keeping the Owner's Operating Manual

Keep this Manual in the box on the left side of the ROPS.

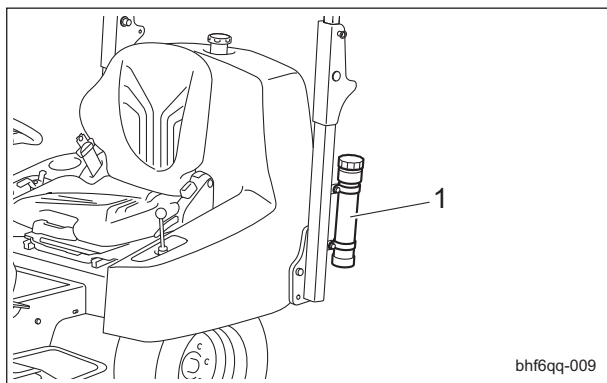

Keeping the Owner's Operating Manual_001

1	Box
---	-----

QR Code

A QR code label is affixed on the machine.

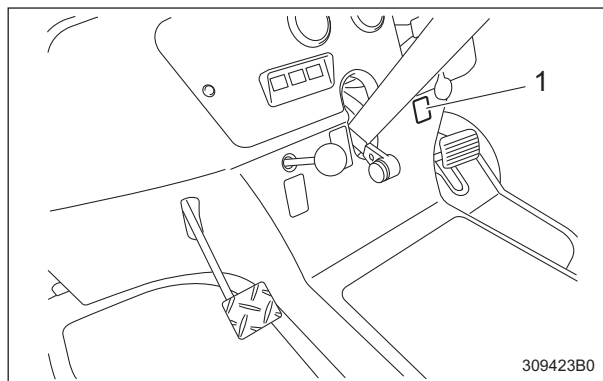

QR Code_001

1	QR code label
---	---------------

Scan the QR code with your smartphone for easy access to Baroness Manual Reference Service where you can browse Owner's Operating Manual and Parts Catalog. <https://doc.baroness-international.com/manuals/LM331>



QR Code_002

Note:
A QR code for mower unit is printed on the serial number plate.

Introduction

Read this manual carefully to ensure that you thoroughly understand how to properly operate and maintain the product, and to avoid causing injury to yourself or others.

The operator is responsible for operating the product properly and safely.

Maintenance service for this machine should be performed by a mechanic with expertise.

If you have any questions concerning maintenance or genuine parts, please contact a Baroness dealer or Kyoisha.

When making inquiries about your product, please specify the model and serial number.

When loaning or transferring the product, please also provide this manual together with the product.

Kyoisha Co., Ltd.

Warning Symbols

This manual uses the following warning symbols for handling precautions that are important for your safety.



696cq5-001

Warning symbol

This symbol indicates the articles regarding “Danger,” “Warning,” or “Caution.”

Those articles describe important safety precautions and so read them carefully to understand completely before operating the machine.

Failure to adequately follow these safety precautions may cause an accident.

Danger

This symbol indicates that serious injury or death will occur if the warning is ignored.

Warning

This symbol indicates that serious injury or death may occur if the warning is ignored.

Caution

This symbol indicates that injury or damage to property may occur if the warning is ignored.

Important

This symbol indicates precautions on the mechanism of the machine.

Precautionary Statement

 Caution

The information described in this manual is subject to change for improvement without prior notice.

When replacing parts, be sure to use genuine Baroness parts or parts designated by Kyoeshia.

Note that the Baroness product warranty may not apply to defects caused by the use of parts from other companies.

Prior to use, carefully read the following manuals to thoroughly understand the contents for safe and correct operation.

- Baroness Owner's Operating Manual
- The Engine's Owner's Manual
- The Battery's Owner's Manual

Purpose

This product is intended for cutting turf grass at golf courses.

Do not use this product in any way other than its intended purpose, and do not modify this product.

Operating this product for other purposes and modifying it may be very dangerous and may cause damage to the product.

In addition, this product is not authorized for operation as a special motor vehicle. Do not operate it on public roads.

LM331

Introduction

Safety	Page 1-1	Repair	Page 7-1
Safe Operating Practices	Page 1-2	Precautions for Repair	Page 7-2
Disposal	Page 2-1	Adjustment and Replacement	Page 7-2
Recycle and Waste Disposal	Page 2-2	Towing	Page 7-6
Product Overview	Page 3-1	Appended Table	Page 8-1
Specifications	Page 3-2	Tightening Torques	Page 8-2
Names of Each Section	Page 3-5	Maintenance Schedule	Page 8-6
Regulation Decals	Page 3-5	List of Adjusted Value	Page 8-9
Safety Signs and Instruction Signs	Page 3-10		
Operation Decals	Page 3-15		
Description of Functions	Page 4-1		
Proximity Sensor	Page 4-2		
2WD/3WD Selector Lever	Page 4-2		
Light Switch	Page 4-2		
Throttle Lever	Page 4-3		
Mower Unit Up/Down Lever	Page 4-3		
Reel Rotation Switch	Page 4-3		
Reel Reverse Switch	Page 4-4		
Reel Rotation/Stop Switching Lever	Page 4-4		
Traveling Pedal	Page 4-4		
Brake Pedal	Page 4-5		
Parking Brake Lever	Page 4-5		
Battery Cutoff Switch	Page 4-5		
Instruments in the Meter Panel	Page 4-6		
Handling Instructions	Page 5-1		
Operations Before Service	Page 5-2		
Inspection and Cleaning	Page 5-4		
Adjustment before Work	Page 5-16		
Start/Stop of Engine	Page 5-17		
Parking and Stopping	Page 5-19		
Move	Page 5-19		
Cutting Work	Page 5-20		
Transporting	Page 5-21		
Maintenance	Page 6-1		
Precautions for Maintenance	Page 6-2		
Jacking Up The Machine	Page 6-2		
Greasing	Page 6-4		
Lubrication	Page 6-7		
Adjustment and Replacement	Page 6-8		
Storage	Page 6-18		

LM331

Contents

Safe Operating Practices Page 1-2

Training Page 1-2

Preparation Page 1-2

Operation Page 1-3

Maintenance Page 1-4

Storage Page 1-5



Safety

Failure to adequately follow these safety precautions may cause an accident resulting in injury or death.

Danger

This product is designed to ensure safe operation and has been tested and inspected thoroughly before shipment from the factory. The product is equipped with safety devices to prevent accidents.

However, whether the product demonstrates its original performance level depends on the manner in which it is operated and handled, as well as the manner in which it is managed on a daily basis.

Inappropriate use or management of the product may result in injury or death.

Observe the following safety instructions to ensure safe operation.

Safe Operating Practices

Training

1. Read this manual and other training material carefully.

Be familiar with the controls, safety signs, and the proper use of the equipment.

2. If the operator or mechanic can not read the language used in this manual, it is the owner's responsibility to explain this material to them.

3. All operators and mechanics should seek and obtain professional and practical instruction.

The owner is responsible for training the users.

Such instruction should emphasize:

- [1] The need for care and concentration when working with ride-on machines.

- [2] Control of a ride-on machine sliding on a slope will not be regained by the application of the brake.

The main reasons for loss of control are

- Insufficient wheel grip
- Being driven too fast
- Inadequate braking
- The type of machine is unsuitable for its task
- Lack of awareness of the effect of ground conditions, especially slopes
- Incorrect hitching and load distribution

4. Never allow children or people unfamiliar with these instructions to use or service the machine.

Local regulations may restrict the age of the operator.

5. The owner/user can prevent and is responsible for accidents or injuries occurring to themselves, other people, or property.
6. Keep in mind that the owner, operator, and mechanic are responsible for accidents or hazards occurring to other people or their property.
7. The ROPS is an integral and effective safety device.
Do not remove or alter the ROPS.
8. Replace a damaged ROPS.
Do not repair or alter.
9. You can find additional safety information where needed throughout this manual.
10. Determine the left and right sides of the machine from the normal operating position.

Preparation

1. Evaluate the terrain to determine what accessories and attachments are needed to properly and safely perform the job.
Only use accessories and attachments approved by the manufacturer.
2. While operating, always wear substantial footwear, long trousers, hard hat, safety glasses, mask, and ear protection.
Long hair, loose clothing, or jewelry may get tangled in moving parts.
Do not operate the equipment when barefoot or wearing open sandals.
3. Inspect the area where the equipment is to be used and remove all objects such as rocks, toys and wire which can be thrown by the machine.
4. Keep children out of the operating area and under the watchful care of a responsible adult other than the operator.
5. Exercise care in the handling of fuel.

Warning

Fuel is highly flammable.

Take the following precautions:

- [1] Store fuel in containers specifically designed for this purpose.

- [2] Add fuel before starting the engine.
Never remove the cap of the fuel tank or add fuel while the engine is running or when the engine is hot.
- [3] Refuel outdoors only and do not smoke while refueling.
- [4] If fuel is spilled, do not attempt to start the engine but move the machine away from the area of spillage and avoid creating any source of ignition until petrol vapours have dissipated;
- [5] Replace all fuel tanks and container caps securely.
6. Check that operator's presence controls, safety switches and shields are attached and functioning properly.
Do not operate unless they are functioning properly.
7. If the brake operation is faulty, be sure to adjust or repair them before operating the machine.
8. Replace faulty mufflers.
9. On multi-cylinder/multi-reel machines, take care as rotating one cylinder/reel can cause other cylinders/reels to rotate.
8. Never operate while people, especially children, or pets are nearby.
9. Only operate in good light, keeping away from holes and hidden hazards.
10. Do not operate the machine when there is the risk of lightning.
11. Do not stop or start suddenly.
12. Look behind and down before backing up to be sure of a clear path.
13. Slow down and use caution when making turns and crossing roads and sidewalks.
14. Use care when approaching blind corners, shrubs, trees, or other objects that may obscure vision.
15. Do not take your eyes off the road ahead.
Do not operate the machine with no hands.
16. Keep a folding ROPS in the raised and locked position and use the seat belt when operating the machine.
17. Lower a folding ROPS temporarily only when absolutely necessary.
Do not wear the seat belt when folded down.
There is no rollover protection when a folding ROPS is in the down position.
18. Remember there is no such thing as a safe slope.
Travel on grass slopes requires particular care.
To guard against overturning, follow these instructions.

Operation

1. Do not operate the machine under the influence of alcohol or drugs.
2. Do not operate the engine in a confined space where dangerous carbon monoxide fumes can collect.
3. Be sure all drives and shift are in neutral and parking brake is engaged before starting engine.
Only start engine from the operator's position.
Use seat belts if provided.
4. Do not change the engine governor settings or overspeed the engine.
Operating the engine at excessive speed may increase the hazard of personal injury.
5. Never operate the machine with damaged guards, shields, or without safety protective devices in place.
Be sure all interlocks are attached, adjusted properly, and functioning properly.
6. Keep hands and feet away from the rotating parts.
7. Do not carry passengers.
- [1] Do not stop or start suddenly when going up or downhill.
- [2] Engage clutch slowly, always keep machine in gear, especially when traveling downhill.
- [3] Machine speeds should be kept low on slopes and during turns.
- [4] Stay alert for humps and hollows and other hidden hazards.
19. Never use the machine on a slope with an angle of gradient that is greater than that specified or in a place where there is a danger of the machine slipping.
20. Use extra care while operating machine with a grass catcher or other attachments.
They can affect the stability of the machine.
21. Disengage drive to the cutting unit(s), when other than operating.

Safety

22. Do the following before leaving the operator's position.
 - [1] Stop on level ground.
 - [2] Disengage the all drives.
 - [3] Set the parking brake.
 - [4] Stop the engine.
 - [5] Remove the ignition key.
23. Stop the engine in the following conditions.
 - [1] Before refuelling.
 - [2] Before removing the grass catcher.
 - [3] Before making height or depth adjustment unless adjustment can be made from the operator's position.
 - [4] Before clearing blockages.
 - [5] Before checking, cleaning or working on the machine.
 - [6] After striking a foreign object or if an abnormal vibration occurs.
Inspect the machine for damage and make repairs before restarting and operating the equipment.
24. Reduce the throttle setting during engine run-out.
25. Do not direct discharge material toward anyone.
Avoid discharging material against a wall or obstruction.
Material may ricochet back toward the operator.
26. Take care when loading or unloading the machine into a trailer or a truck.
Load or unload the machine in a flat and safe place.
Before loading or unloading, set the parking brake on the truck or trailer, stop the engine, and chock the wheels.
When transporting the machine on a truck or a trailer, set the parking brake, stop the engine, and fasten the machine to the truck with a rope or other suitable restraining device that has sufficient strength.
When using a running board, select one with sufficient strength, length, and width and that will not cause the machine to slip.
27. Close the fuel valve before transporting the machine.
2. Implement the following work before adjusting, cleaning or repairing.
 - [1] Stop the machine on level ground.
 - [2] Disengage drive to the cutting unit(s).
 - [3] Lower the cutting unit(s) and/or attachment(s).
 - [4] Set the parking brake.
 - [5] Stop the engine.
 - [6] Remove the ignition key.
 - [7] Wait for all movement to stop.
3. Allow the engine/muffler to cool before checking/maintenance.
4. To reduce the fire hazard, keep hot parts such as the engine and silencer/muffler, battery compartment and fuel storage area free of grass, leaves, or excessive grease. Clean up oil or fuel spillage.
5. Appropriately manage and correctly use the tools necessary for servicing or adjusting the machine.
6. Disconnect battery before making any repairs.
Disconnect the negative terminal first and the positive last.
Reconnect positive first and negative last.
7. Use jack stands to support components when required.
8. Keep hands and feet away from moving parts.
If possible, do not make adjustments with the engine running.
9. Make sure that parts such as wires are not touching each other and that their covers have not come off.
10. Keep all parts in good working condition and all hardware tightened.
Replace all worn or damaged decals.
11. Keep all nuts, bolts and screws tight to be sure the equipment is in safe working condition.
12. Carefully release pressure from components with stored energy.
13. Be sure to depressurize the hydraulic system before performing maintenance operations on it such as removing hydraulic equipment.
14. Check whether line connectors in the hydraulic system are properly tightened.
Before applying hydraulic pressure, check the connections of the hydraulic pressure lines and the condition of the hoses.

Maintenance

1. Never allow untrained personnel to service machine.

15. When checking the hydraulic circuit for pinhole leaks or oil leakage from nozzles, do not use your hands.
Use items such as paper or corrugated cardboard to find leakage points.
Be extremely careful with high-pressure oil as it may pierce your skin, resulting in an injury.
If fluid is injected into the skin it must be surgically removed within a few hours by a doctor familiar with this form of injury or gangrene may result.
 16. Use care when checking the cylinders/reels and bed knives.
Wear gloves and use caution when servicing them.
 17. Be careful during adjustment of the machine to prevent entrapment of the fingers between moving blades and fixed parts of the machine.
 18. On multi-cylinder/multi-reel machines, take care as rotating one cylinder/reel can cause other cylinders/reels to rotate.
 19. Check the grass catcher frequently for wear or deterioration.
 20. Charge batteries in an open well ventilated area, away from spark and flames.
Unplug charger before connecting or disconnecting from battery.
Wear protective clothing and use insulated tools.
 21. If the fuel tank has to be drained, do this outdoors.
7. Swallowing engine coolant can cause injury or death; keep out of reach from children and pets.

Storage

1. When machine is to be parked, stored, or left unattended, lower the cutting unit(s) and/or attachment(s) unless a positive mechanical lock is provided.
2. Allow the engine to cool before storing in any enclosure.
3. Only cover the machine with a sheet after hot parts have sufficiently cooled down.
4. Never store the equipment with fuel in the tank inside a building where fumes may reach an open flame or spark.
5. If the engine is provided with a shut-off valve, shut off valve while storing or transporting.
6. Do not store fuel near flames.

Recycle and Waste Disposal Page 2-2

About RecyclePage 2-2

About Waste Disposal Page 2-2

Disposal

Disposal

Recycle and Waste Disposal

About Recycle

Recycling battery etc. is recommended for environmental conservation and economical use of resources.

It may be required by local laws.

About Waste Disposal

Make sure that waste generated when servicing or repairing the machine is disposed of in accordance with local regulations. (e.g. waste oil, antifreeze, rubber products, and wires etc.)

Specifications Page 3-2

SpecificationsPage 3-2

Mower UnitsPage 3-3

Sound Pressure Level Page 3-4

Sound Power Level Page 3-4

Vibration LevelPage 3-4

Carbon Dioxide (CO₂) EmissionsPage 3-4**Names of Each Section Page 3-5****Regulation DecalsPage 3-5**

Positions of Regulation Decals Page 3-5

Description of Regulation Decals Page 3-6

Safety Signs and Instruction Signs ... Page 3-10About Safety Signs and Instruction
SignsPage 3-10Positions of Safety Decals and
Instruction Decals Page 3-10Description of Safety Decals and
Instruction Decals Page 3-11**Operation Decals Page 3-15**

Positions of Operation Decals Page 3-15

Description of Operation Decals Page 3-16

Product Overview

Specifications

Specifications

Model		LM331	
Name		5-Unit Reel Mower	
Mower unit type		26 in	
Dimensions	Total length		254 cm 100.00 in
	Total width		212 cm 83.46 in
	Total height	Handle	126 cm 49.61 in
		ROPS	196 cm 77.17 in
Weight	Machine (3WD, empty fuel tank)	LH66 with groomer, CR brush, ROPS, Light, Ball proof net without grass catcher	910 kg 2006.17 lb
		LS66 with CR brush, ROPS, Light, Ball proof net without grass catcher	862 kg 1900.35 lb
	Grass catchers (for one machine)		15.0 kg 33.07 lb
	Minimum turning radius		
		LH66	Front wheel (outer wheel) outside 198 cm 77.95 in
			Outer side of unit 228 cm 89.76 in
		LS66	Front wheel (outer wheel) outside 198 cm 77.95 in
			Outer side of unit 227 cm 89.37 in
Engine	Model		Kubota D902-E4B
	Type		Vertical Water-cooled 4-cycle diesel engine
	Total displacement		898 cm ³ (0.898 L) 54.79 cu.in.
	Maximum output		-
	Rated output		13.4 kW (18.2 PS)/2,600 rpm
Fuel tank capacity		Diesel 25.0 dm ³ (25.0 L) Diesel 6.61 U.S.gals	
Fuel consumption		257 g/kW · h (rated output) 189.0 g/PS · h (rated output)	
Engine oil capacity		3.7 dm ³ (3.7 L) 0.98 U.S.gals	
Coolant volume		3.1 dm ³ (3.1 L) 0.82 U.S.gals	
Hydraulic tank capacity		26.0 dm ³ (26.0 L) 6.87 U.S.gals	
Transmission oil capacity		-	
Operating width (Mowing width)		183 cm 72.05 in	
Operating height (Mowing height)		LH66 8.0 - 45.0 mm 0.315 - 1.772 in	
		LS66 10.0 - 46.0 mm 0.394 - 1.811 in	
Number of Blades		5, 7, 9	
Drive	Traveling		HST (2WD/3WD selectable)
	Mowing		Hydraulic (Gear motor drive)

Product Overview

Speed (HST)	Forward	2WD	14.0 km/h	8.70 mph
		3WD	8.7 km/h	5.41 mph
	Reverse	2WD	10.0 km/h	6.22 mph
		3WD	6.2 km/h	3.85 mph
Speed (Mechanical)			-	
Efficiency			11,712 m ² /h (8.0 km/h x mowing width x 0.8)	2.89 acres/hour (4.97 mph x mowing width x 0.8)
Maximum inclination for operation			15 degrees	
Tire size	Front wheel		20 x 12.00-10 4P	
	Rear wheel		20 x 8.00-10 4P	
Tire pneumatic pressure	Front wheel		140 kPa (1.4 kgf/cm ²)	20 psi
	Rear wheel		140 kPa (1.4 kgf/cm ²)	20 psi
Battery			75D23L	
Engine plug			-	

The factory default maximum engine rpm is 2,800 rpm.

Mower Units

Baroness mower unit that can fit this machine is the model marked with a circle in the "Attachable unit" column.

LM331

Baroness mower unit	Model		Attachable unit	Remarks
Small diameter mower unit	LH52	22 in	-	
Multi configuration mower unit	LH62	22 in	-	
	LH66	26 in	○	
Standard mower unit	LS62	22 in	-	
	LS66	26 in	○	

Product Overview

Sound Pressure Level

Sound pressure level

This machine was confirmed to have a continuous A-weighted sound pressure level of 85 dB by measuring identical machines in accordance with the procedure specified in ISO5395-1:2013.

Sound Power Level

Sound Power Level

This machine was confirmed to have a sound power level of 103 dB by measuring identical machines in accordance with the procedure specified in ISO 5395-1:2013.

Vibration Level

Hand-Arm Vibration

This machine was confirmed not to exceed a vibration level of 2.5 m/s² to hands and arms by measuring identical machines in accordance with the procedure specified in ISO 5395-1:2013.

Whole Body Vibration

This machine was confirmed not to exceed a vibration level of 0.5 m/s² to the whole body by measuring identical machines in accordance with the procedure specified in ISO 5395-1:2013.

Carbon Dioxide (CO₂) Emissions

For the CO₂ value on the engine of this machine, refer to the engine's owner's manual.

Product Overview

Names of Each Section

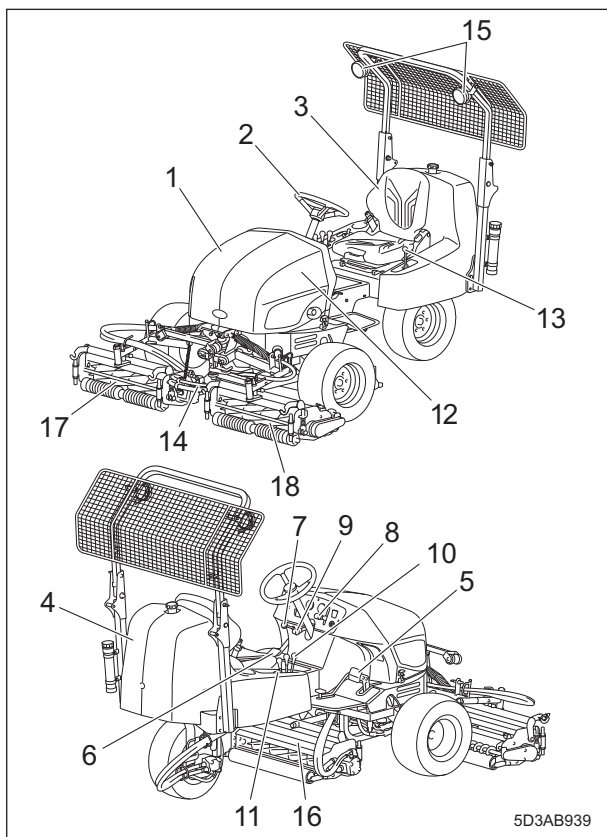

Names of Each Section_001

1	Hood
2	Steering wheel
3	Seat
4	Rear cover
5	Traveling pedal
6	Brake pedal
7	Parking brake lever
8	Throttle lever
9	Tilt lever
10	Mower unit up/down lever
11	Reel rotation switch
12	Reel reverse switch
13	2WD/3WD selector lever
14	Reel rotation/stop switching lever
15	Light
16	Mower unit #1
17	Mower unit #2
18	Mower unit #3

Regulation Decals

Positions of Regulation Decals

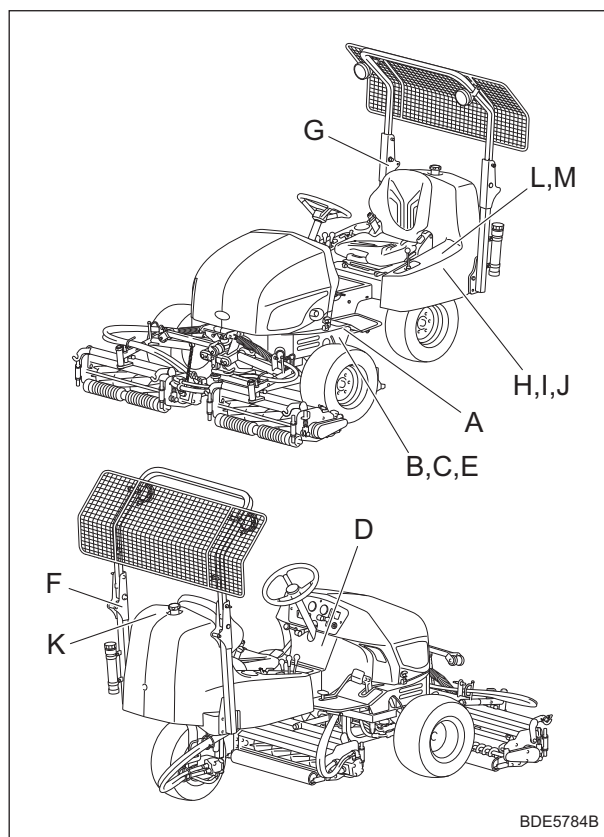

Positions of Regulation Decals_001

A	Serial number plate
B	Specification decal
C	UKCA mark
D	Noise emission decal
E	Year of manufacture decal
F	ROPS compliance decal
G	ROPS caution decal
H	Battery capacity decal
I	Recycle decal
J	Battery danger decal
K	Indicating diesel fuel decal
L	California Proposition65 decal (riding type)
M	Spark arrester warning decal

Product Overview

Description of Regulation Decals

Serial Number Plate

The serial number plate indicates the model and serial number of the machine.

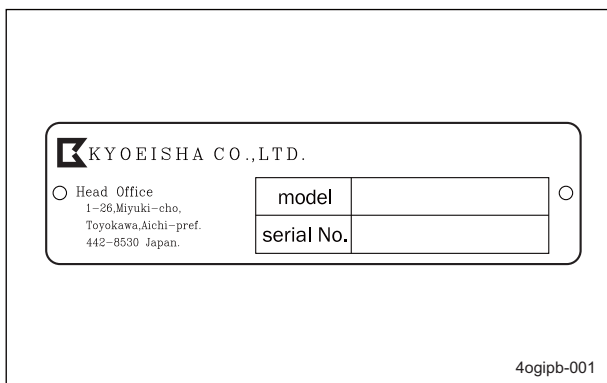

Serial Number Plate_001

UKCA Mark

(For UK)

UKCA mark indicates that the machine sold in the UK complies with the UK requirements.



UKCA Mark_001

Specification Decal

(For Europe)

CE mark indicates that the machine sold in the EU nations complies with the EU requirements.

The Specification decal indicates the CE marking, model, and weight, etc.

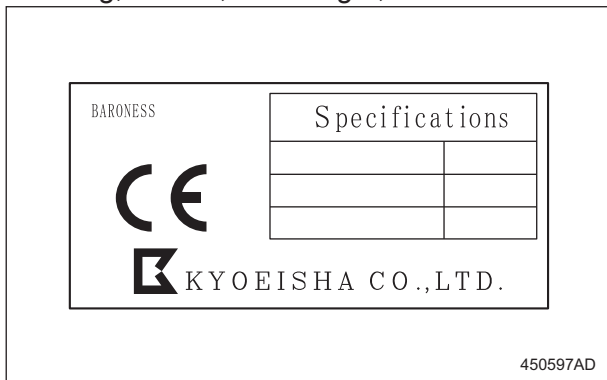

Specification Decal_001

Noise Emission Decal

(For Europe)

The noise emission decal indicates the sound power level determined by measuring identical machines in accordance with the procedure specified in the EC directives.

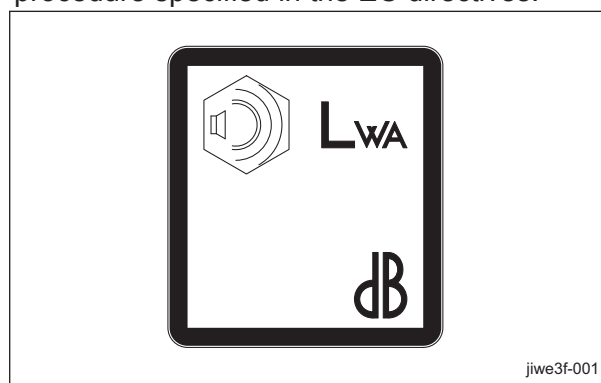

Noise Emission Decal_001

Year of Manufacture Decal

(For Europe)

The year of manufacture decal indicates the year when this machine was manufactured.

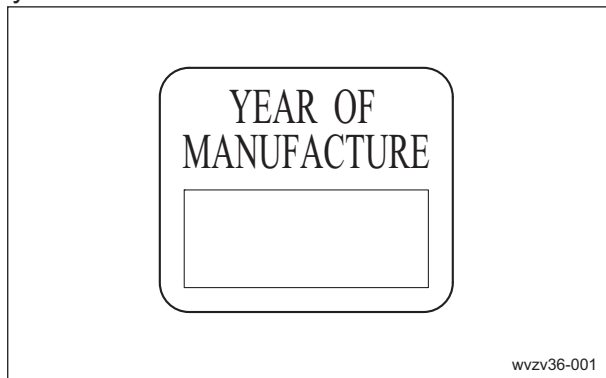

Year of Manufacture Decal_001

ROPS Caution Decal

ROPS caution decal describes the following caution messages.

- Replace damaged ROPS.
- Do not repair or revise.

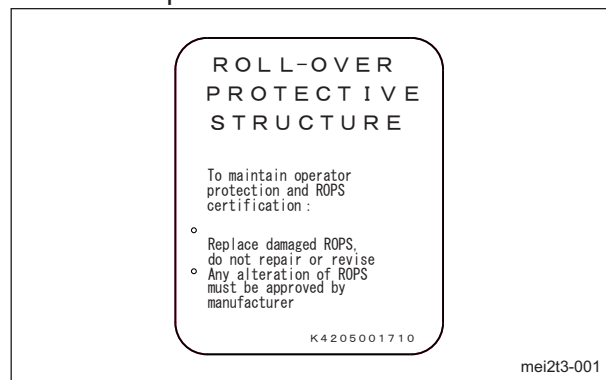

ROPS Caution Decal_001

ROPS Compliance Decal

The ROPS compliance decal indicates the manufacturer, model, etc., in accordance with International Standard ISO 21299:2009.

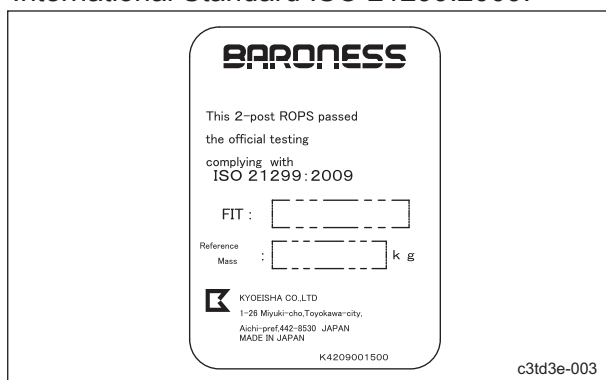

ROPS Compliance Decal_001

Battery Capacity Decal

(For Europe)

The battery capacity decal indicates the capacity by 20HR and CCA.

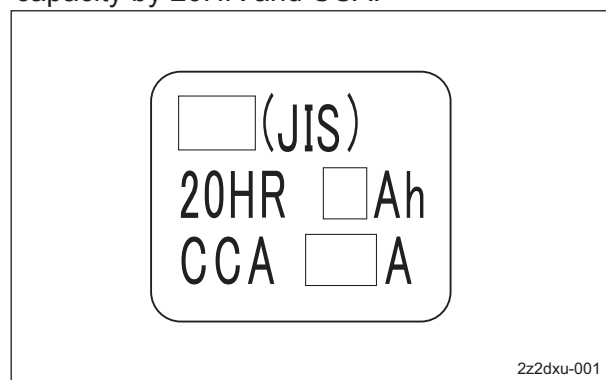

Battery Capacity Decal_001

Product Overview

Recycle Decal

Recycle Decal illustrates Recycle Mark in accordance with local regulation.
(For Europe)

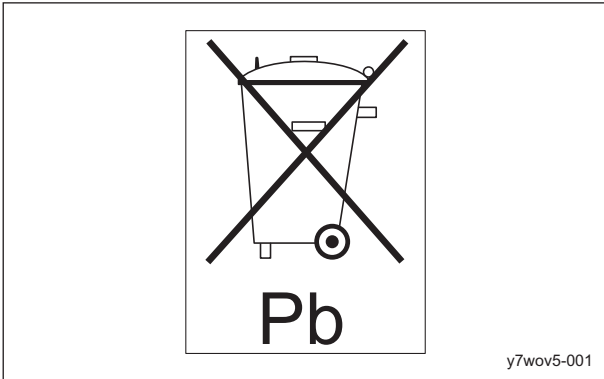

Recycle Decal_001

(For USA)



Recycle Decal_002

Battery Danger Decal

(For USA)
Battery Danger Decal describes handling precautions for battery.

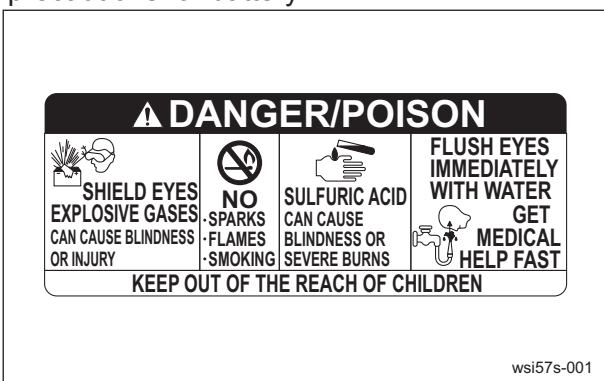

Battery Danger Decal_001

Indicating Diesel Fuel Decal

(for USA)
It indicates the fuel to be used.
Use low sulfur or ultra-low sulfur diesel fuel (sulfur-free diesel fuel).

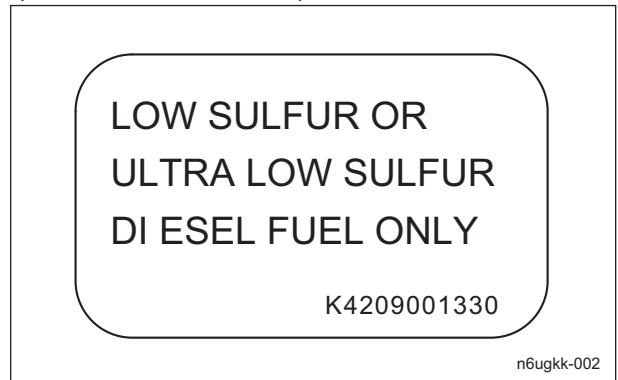

Indicating Diesel Fuel Decal_001

California Proposition 65 Decal (Riding Type)

(For the State of California, USA)
California Proposition 65 decal describes the warning messages as required by California Proposition 65.

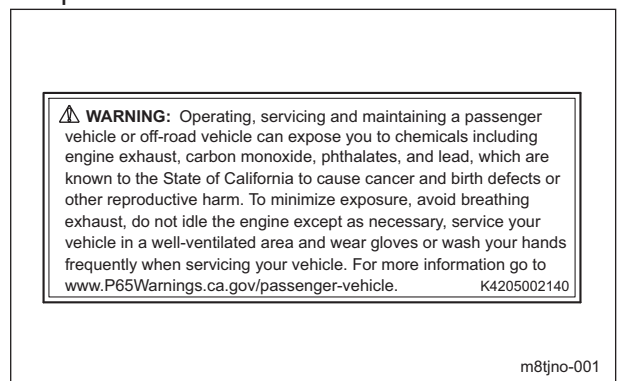

California Proposition 65 Decal (Riding Type)_001

Spark Arrester Warning Decal

(For the State of California, USA)

Spark arrester warning decal describes the warning messages as required by California Public Resources Code.

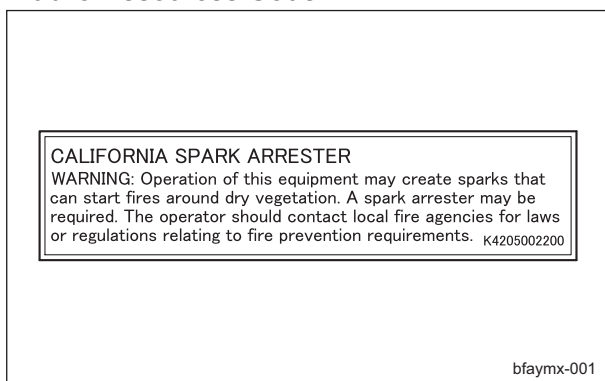

Spark Arrester Warning Decal_001

Product Overview

Safety Signs and Instruction Signs

About Safety Signs and Instruction Signs

Important

Safety decals and instruction decals are attached to this product. Make sure that they are preserved in their entirety. If they are damaged, become dirty, or peel off, replace them with new ones.

Part numbers for decals that need to be replaced are listed in the parts catalog. Order them from a Baroness dealer or Kyo-eisha.

Positions of Safety Decals and Instruction Decals

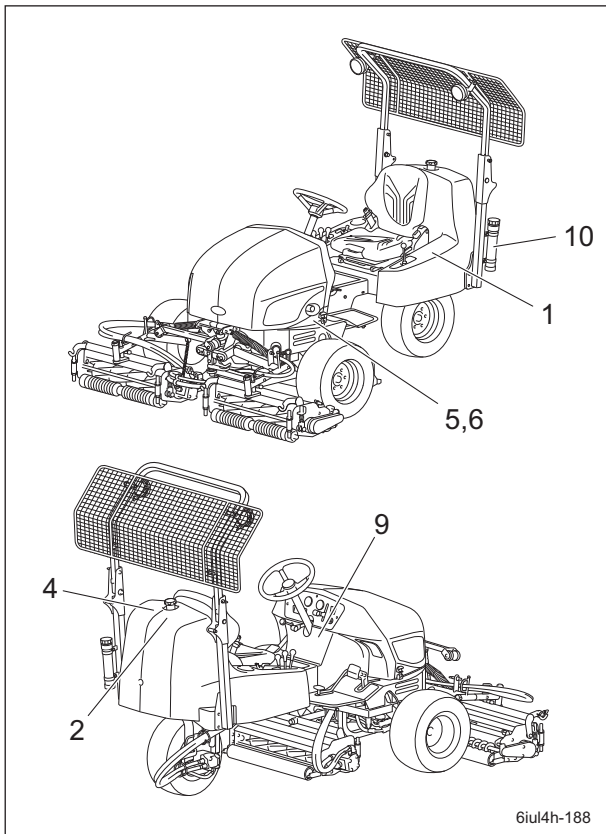

Positions of Safety Decals and Instruction Decals_001

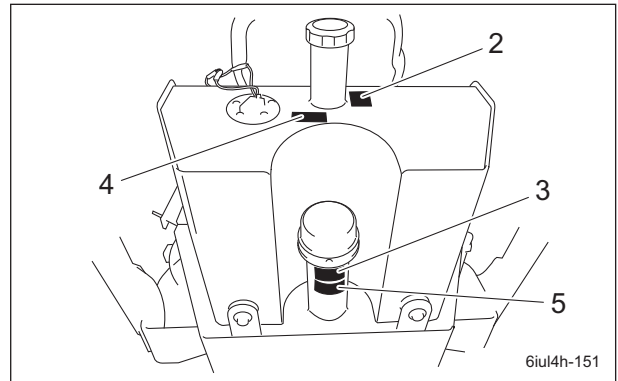

Positions of Safety Decals and Instruction Decals_002

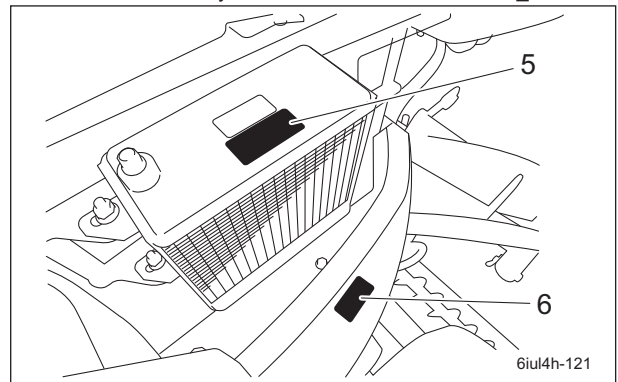

Positions of Safety Decals and Instruction Decals_003

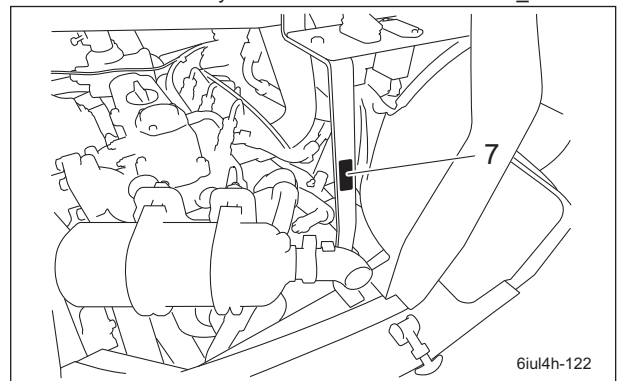

Positions of Safety Decals and Instruction Decals_004

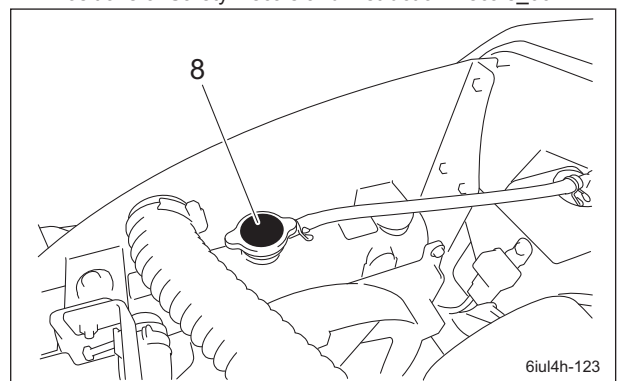

Positions of Safety Decals and Instruction Decals_005

1	Decal, left panel
2	Decal, diesel fuel filler
3	Decal, hydraulic oil
4	Decal, keep away from fire
5	Decal, caution for high temperatures
6	Decal, caution for pinching
7	Decal, caution to getting entangled
8	Decal, caution for spouting coolant
9	Decal, caution to noise
10	Decal, read Owner's Operating Manual

Description of Safety Decals and Instruction Decals

Left panel decal

LM331--0928Z0
Decal, left panel

1.



Warning

Read the Owner's Operating Manual.

2.



Warning

Apply the parking brake, stop the engine, and then remove the ignition key before leaving the machine.

3.

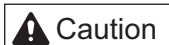

Caution

Flying objects - Be sure that people around the machine keep a safe distance away.

4.



Warning

May cut your hand or leg - Keep hands and feet away from moving parts.

5.



Warning

Be careful of exhaust emissions.

6.

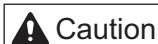

Caution

Rollover - Do not work on slopes of 15 degrees or more.

When you descend a slope, drive at low speed with the mower units lowered.

Fasten your seatbelt.

7.



Warning

Rollover - Do not switch between 2WD and 3WD while traveling on downward slopes.

Do not set the reel rotation switch to the "Rotation" (reel rotation) position while traveling on downward slopes.

Do not travel in three-wheel drive on downward slopes.

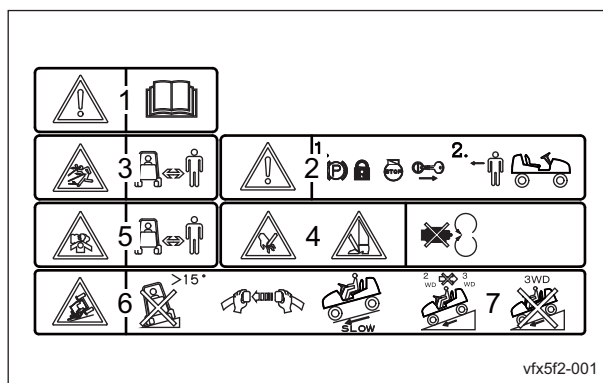

Left panel decal_001

Product Overview

Diesel Fuel Icon

K4209001000
Diesel fuel icon
Use diesel fuel.

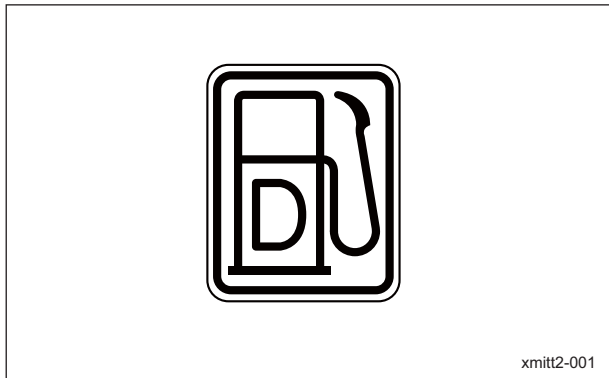

Diesel Fuel Icon_001

Hydraulic Oil Icon

K4209000980
Hydraulic oil icon
Read the Owner's Operating Manual.

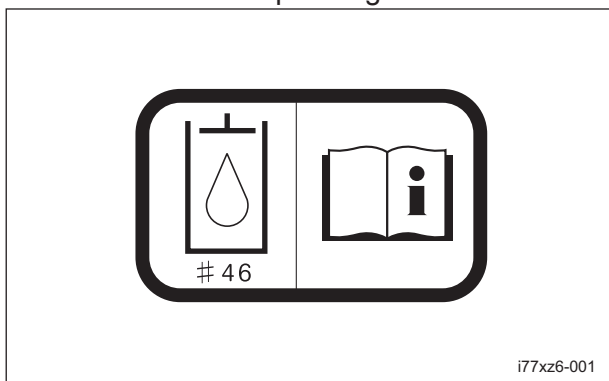

Hydraulic Oil Icon_001

Fire Prohibited Decal

K4205001940
Decal, fire prohibited

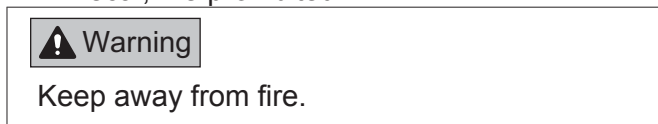

Fire Prohibited Decal_001

Caution for High Temperatures Decal

K4205001920
Decal, caution for high temperatures

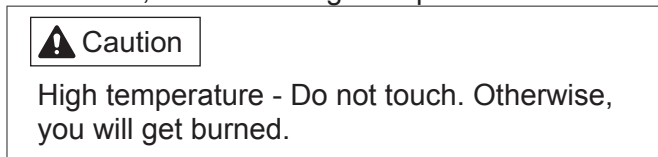

Caution for High Temperatures Decal_001

Caution to Getting Pinched Decal

K4205001930
Decal, caution to getting pinched

Caution

May pinch - There is a risk of being pinched.

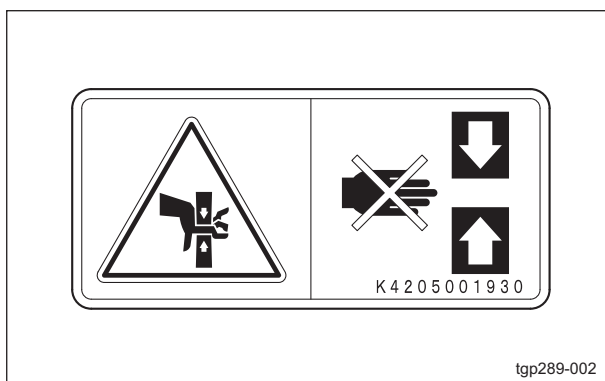

Caution to Getting Pinched Decal_001

Caution to Getting Entangled Decal

K4205001910
Decal, caution to getting entangled

Warning

Watch for rotating parts - Keep your hands away from the belts while the engine is running.

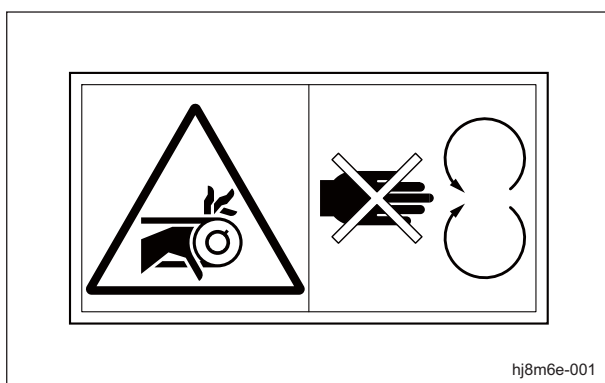

Caution to Getting Entangled Decal_001

Caution for Spouting Coolant Decal

K4205001970
Decal, caution for spouting coolant

Caution

Caution for spouting coolant - Do not open while hot.
High temperature - Do not touch. Otherwise, you will get burned.

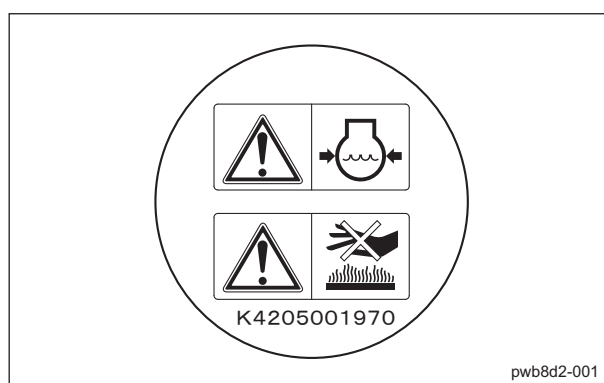

Caution for Spouting Coolant Decal_001

Caution to Noise Decal

K4205002090
Decal, caution to noise

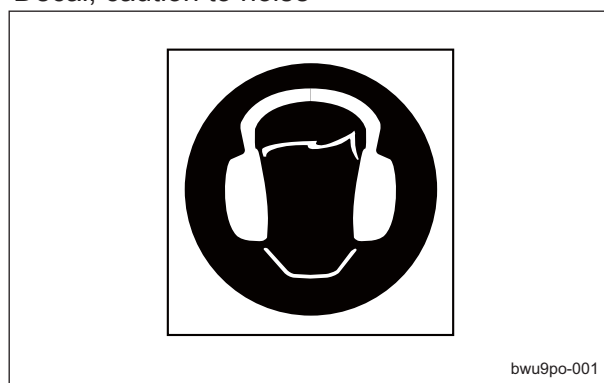

Caution to Noise Decal_001

Product Overview

Decal on Reading Owner's Operating Manual

K4205001560

Decal, read Owner's Operating Manual



Read the Owner's Operating Manual.

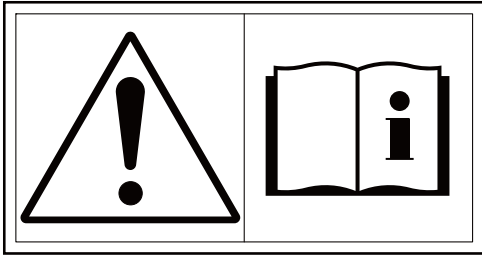

tpfw8-001

Decal on Reading Owner's Operating Manual_001

Operation Decals

Positions of Operation Decals

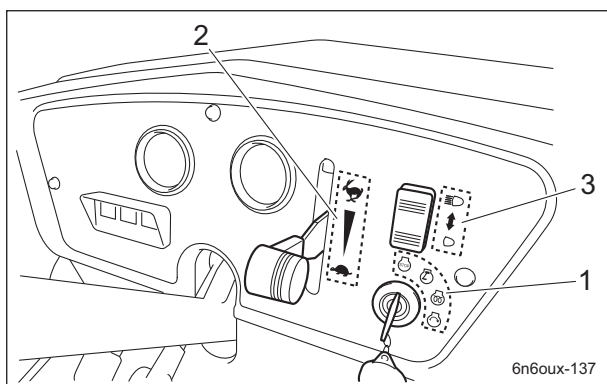

Positions of Operation Decals_001

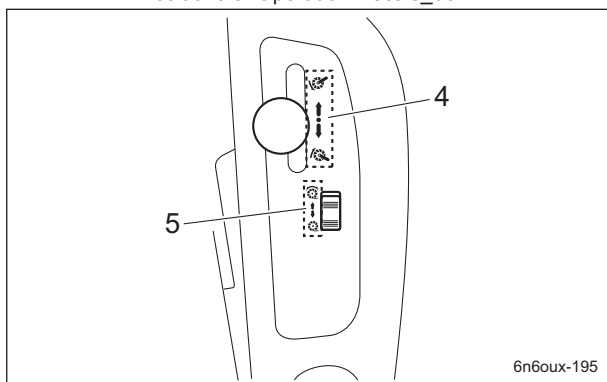

Positions of Operation Decals_002

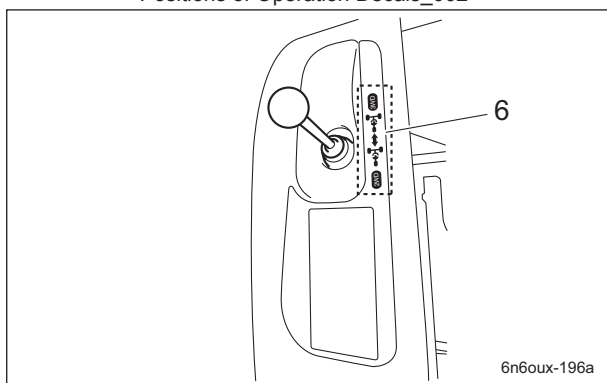

Positions of Operation Decals_003

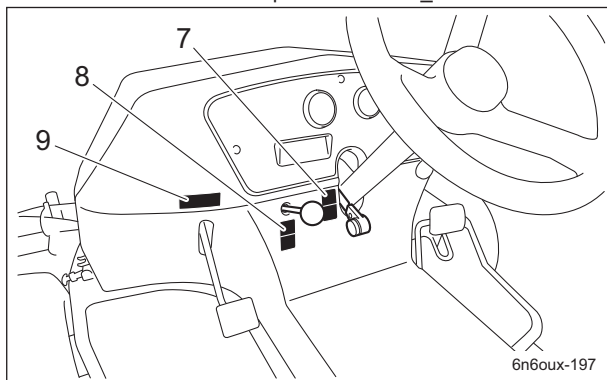

Positions of Operation Decals_004

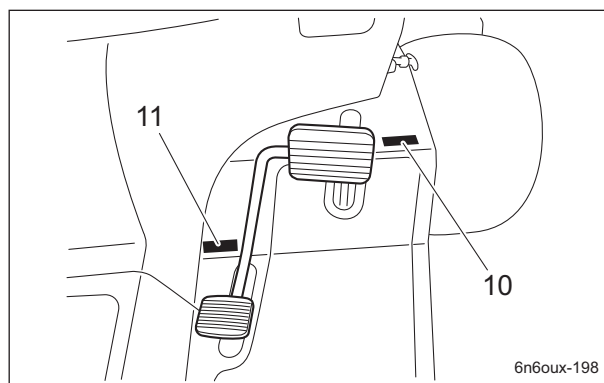

Positions of Operation Decals_005

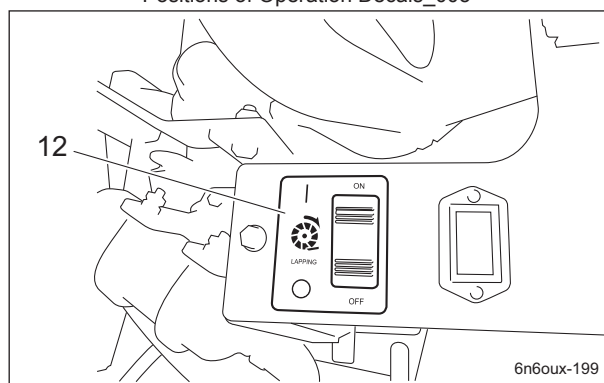

Positions of Operation Decals_006

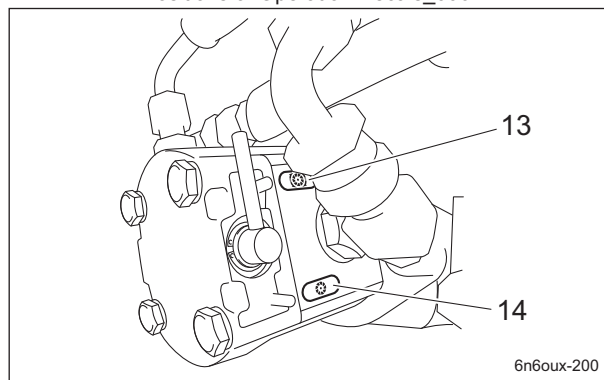

Positions of Operation Decals_007

1	Key switch decal
2	Engine rotation decal
3	Light switch decal
4	Mower unit up/down decal
5	Reel rotation mark
6	2WD - 3WD selector lever decal
7	Tilt steering decal
8	Parking brake decal
9	BRAKE decal
10	FORWARD decal
11	BACKWARD decal
12	Lapping switch decal
13	Reel rotation decal
14	Reel stop decal

Product Overview

Description of Operation Decals

Key Switch Mark

Key switch mark

This indicates the key switch positions.

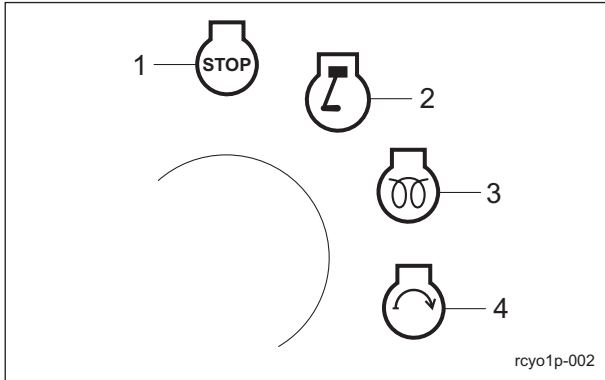

Key Switch Mark_001

1	OFF
2	ON
3	GLOW
4	START

Light Switch Decal

Note:

Depending on the specifications, this function may not be available.

LM331--1105Z0

Light switch decal

This indicates the light switch positions.

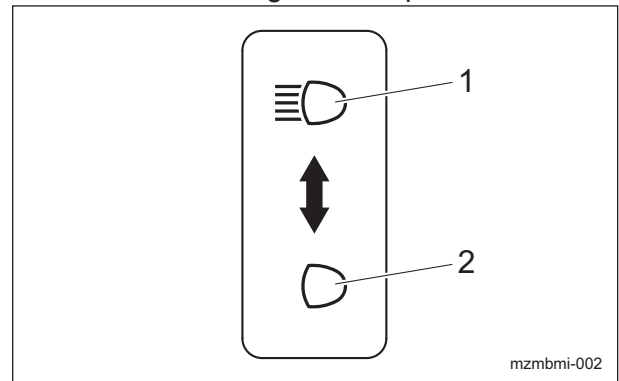

Light Switch Decal_001

1	ON
2	OFF

Engine Rotation Decal

Engine rotation decal

This indicates high/low speed of the engine rotation.

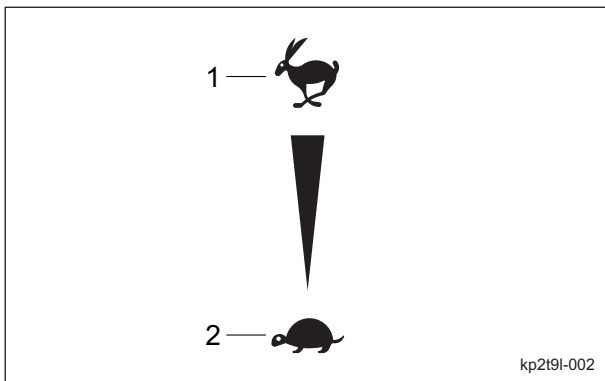

Engine Rotation Decal_001

1	High speed
2	Low speed

Mower Unit Up/Down Decal

Decal, mower unit up/down

This indicates the Up/Down positions of the mower unit.

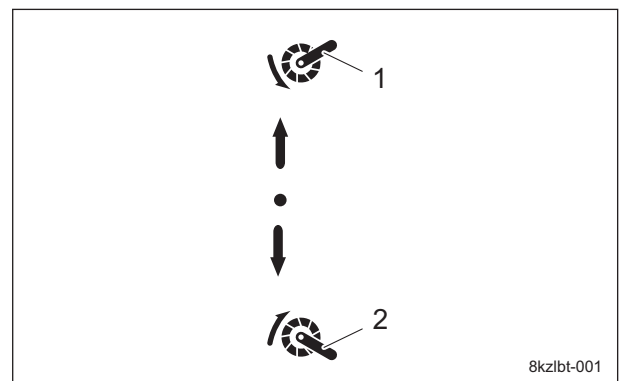

Mower Unit Up/Down Decal_001

1	Down
2	Up

Reel Rotation Mark

Reel rotation mark
It illustrates Rotation/Stop of the reel cutter (cutting cylinder).

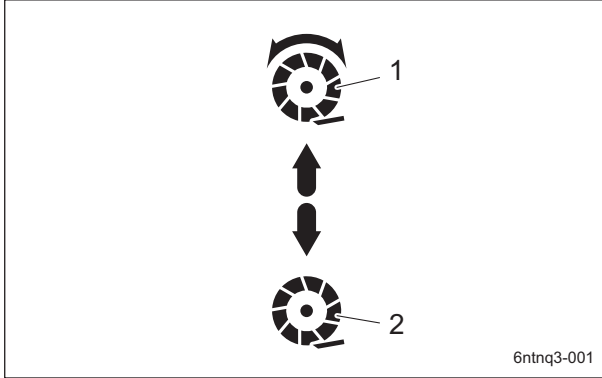

Reel Rotation Mark_001

1	Rotation
2	Stop

Tilt Steering Decal

K4203001500
Tilt steering decal
This illustrates the tilt directions of the steering wheel and the locked/free positions.

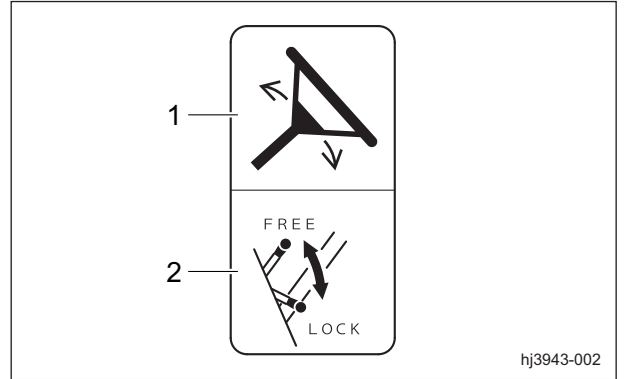

Tilt Steering Decal_001

Parking Brake Decal

K4203001340
Parking brake decal
This shows how to lock and release the parking brake.

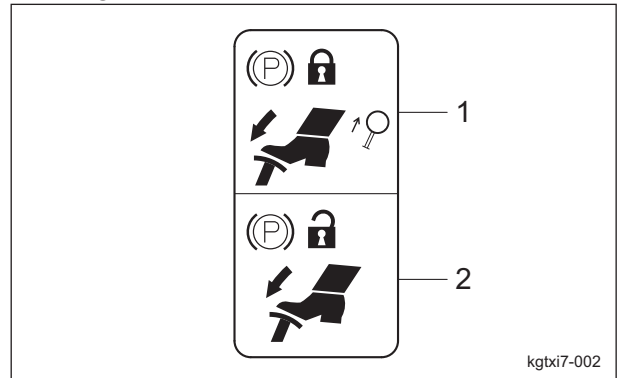

Parking Brake Decal_001

1	Lock
2	Release

2WD - 3WD selector lever decal

2WD - 3WD selector lever decal
This indicates the 2WD/3WD positions.

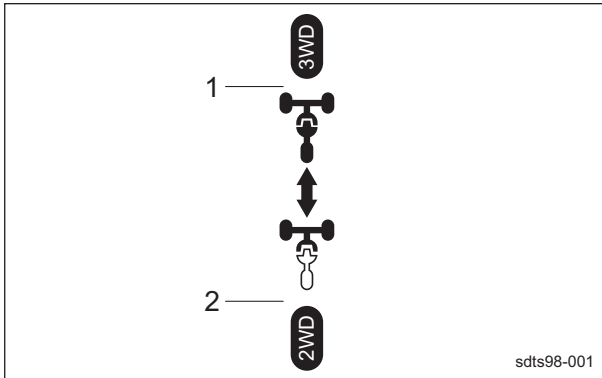

2WD - 3WD selector lever decal_001

1	3WD
2	2WD

Product Overview

BRAKE Decal

K4203001450
Decal, BRAKE
This indicates brake.



BRAKE Decal_001

Lapping switch decal

LM331--0556Z0
Lapping switch decal
This indicates the ON/OFF positions for back lapping.

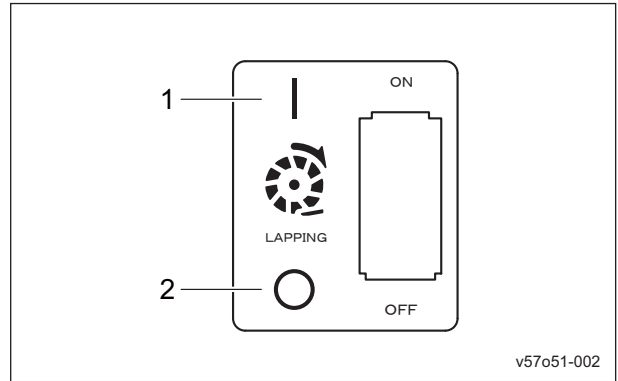

Lapping switch decal_001

1	ON (back lapping rotation)
2	OFF (mowing rotation)

FORWARD Decal

K4203001430
Decal, FORWARD
This indicates forward travel.



FORWARD Decal_001

Reel Rotation Decal

K4203001300
Decal, reel rotation
This indicates rotation of the reel cutter (cutting cylinder).

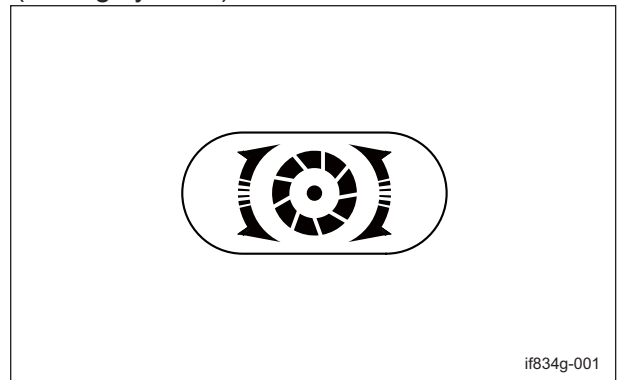

Reel Rotation Decal_001

BACKWARD Decal

K4203001440
Decal, BACKWARD
This indicates backward travel.



BACKWARD Decal_001

Reel Stop Decal

K4203001310

Decal, reel stop

This indicates stop of the reel cutter (cutting cylinder).

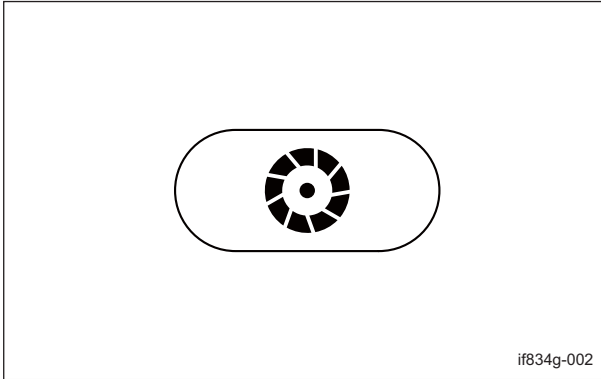

Reel Stop Decal_001

Product Overview

Description of Functions

Proximity Sensor	Page 4-2
2WD/3WD Selector Lever	Page 4-2
Light Switch	Page 4-2
Throttle Lever	Page 4-3
Mower Unit Up/Down Lever	Page 4-3
Reel Rotation Switch	Page 4-3
Reel Reverse Switch	Page 4-4
Reel Rotation/Stop Switching Lever	Page 4-4
Traveling Pedal	Page 4-4
Brake Pedal	Page 4-5
Parking Brake Lever	Page 4-5
Battery Cutoff Switch	Page 4-5
Instruments in the Meter Panel	Page 4-6
Water Temperature Gauge	Page 4-6
Fuel Gauge	Page 4-6
Pilot Lamps	Page 4-6
Hour Meter	Page 4-7
Safety Mechanisms	Page 4-8
Warning Mechanisms	Page 4-8

Description of Functions

Proximity Sensor

There is a proximity sensor on #2 mower arm fulcrum.

This sensor detects the raised or lowered positions of mower unit #2. The information is related to controlling rotation and stop of the reel cutter (cutting cylinder).

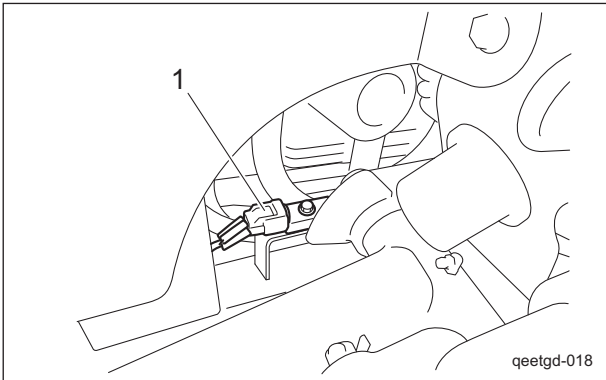

Proximity Sensor_001

1	Proximity sensor
---	------------------

The 2WD/3WD selector lever is located to the left of the driver's seat.

When the lever is shifted forward, 3WD mode is selected. When the lever is shifted backward, 2WD mode is selected.

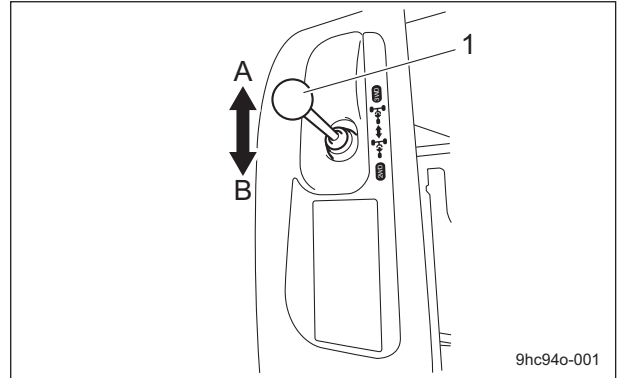

2WD/3WD Selector Lever_001

1	2WD/3WD selector lever
A	3WD
B	2WD

2WD/3WD Selector Lever

Caution

Since traveling on steep downward slopes, wet surfaces and wet grassy downward slopes in 3WD is dangerous, use 2WD. Otherwise, the rear tire may slip and travel control may be lost.

Important

Before switching between 2WD and 3WD operation, make sure that the machine is completely stopped. Otherwise, the hydraulic equipments will malfunction.

Light Switch

Caution

The lights provide auxiliary lighting. Do not travel or operate the machine at night or under poor visibility.

Note:

Depending on the specifications, this function may not be available.

The light switch is located in the meter panel. When the switch is set to the "ON" position, the lights turn on. When it is set to the "OFF" position, the lights turn off.

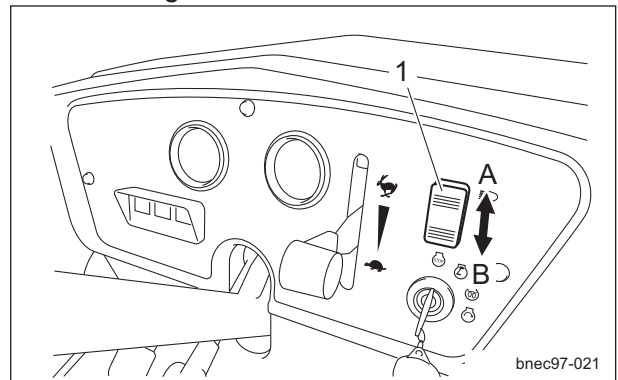

Light Switch_001

1	Light switch
A	ON
B	OFF

Description of Functions

Note:

The lights will not turn on when the key switch is set to the "OFF" position.

Throttle Lever

The throttle lever is located in the meter panel and enables you to adjust the engine rpm. Move the throttle lever toward the "High speed" position to increase the engine rpm, and toward the "Low speed" position to reduce the rpm.

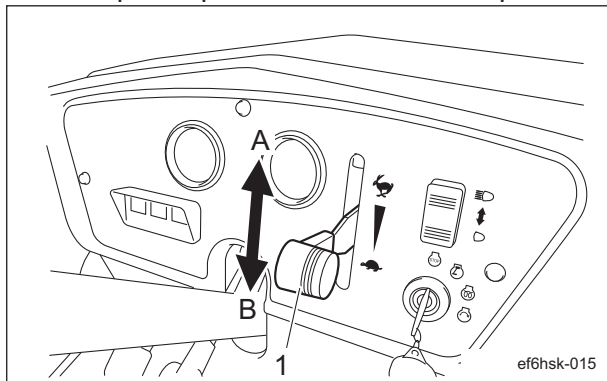

Throttle Lever_001

1	Throttle lever
A	High speed
B	Low speed

Mower Unit Up/Down Lever

Caution

Before raising or lowering the mower units, be sure to sit on the seat.

Caution

Before raising or lowering the mower units, make sure that there are no people around the machine.

Caution

Be careful since shifting the mower unit up/down lever to the "DOWN" position lowers the mowers, even while the engine is stopped.

The mower unit up/down lever is located in the operation panel (to the right of the driver's seat) and raises or lowers the mower units. Shift the lever to the "DOWN" position to lower the mower units, and shift it to the "UP" position to raise the mower units.

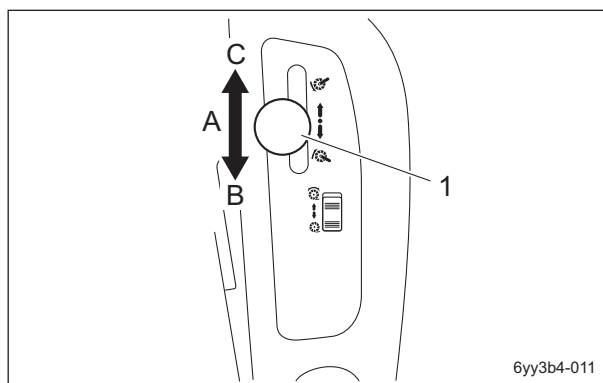

Mower Unit Up/Down Lever_001

1	Mower unit up/down lever
A	Neutral
B	Up
C	Down

Note:

Even if the reel rotation switch is set to the "Rotation" position, the reel cutter (cutting cylinder) stops rotating when the mower units are raised.

Reel Rotation Switch

Caution

Set the reel rotation switch to the "Rotation" position immediately before starting cutting work. At all other times, be sure to leave the reel rotation switch set to the "Stop" position.

The reel rotation switch is located in the operation panel (to the right of the driver's seat) and operates rotation of the reel cutters (cutting cylinders) of the mower units. When the reel rotation switch is set to the "Rotation" position, the reel cutters (cutting cylinders) of all mower units will rotate for cutting work. When the reel rotation switch is set to the "Stop" position, the reel cutters (cutting cylinders) will stop.

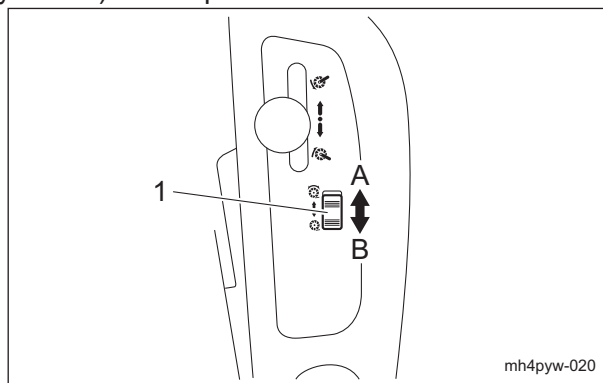

Reel Rotation Switch_001

Description of Functions

Description of Functions

1	Reel rotation switch
A	Rotation
B	Stop

Reel Reverse Switch

Important

Do not switch the reel reverse switch to the "ON" or "OFF" position while the reel cutter (cutting cylinder) is rotating. Otherwise, a hydraulic system malfunction will occur.

Important

If the reel rotation switch is not set to the "Rotation" position, the reel cutter (cutting cylinder) will not rotate.

The reel reverse switch is located under the hood. This switches the rotation direction of the reel cutter (cutting cylinder). When the reel reverse switch is set to the "ON" position, the reel cutters (cutting cylinders) of all mower units rotate in reverse (back lapping rotation). When the reel reverse switch is set to the "OFF" position, the reel cutters (cutting cylinders) rotate normally.

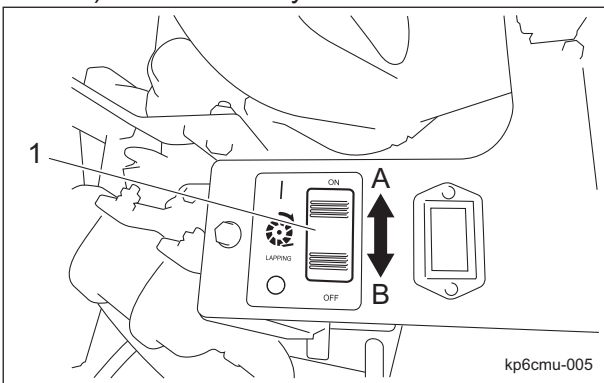

Reel Reverse Switch_001

1	Reel reverse switch
A	ON (reverse rotation)
B	OFF (normal rotation)

Reel Rotation/Stop Switching Lever

Caution

Before operating the reel rotation/stop switching lever, be sure to set the reel rotation switch to the "Stop" position.

The reel rotation/stop switching lever is located on the reel motor attached to each mower unit. It is used during cutting and back lapping. Shift the lever(s) to the "Rotation" position only for the mower unit(s) to be used for cutting or back lapping. Leave the lever(s) for other mower units in the "Stop" position.

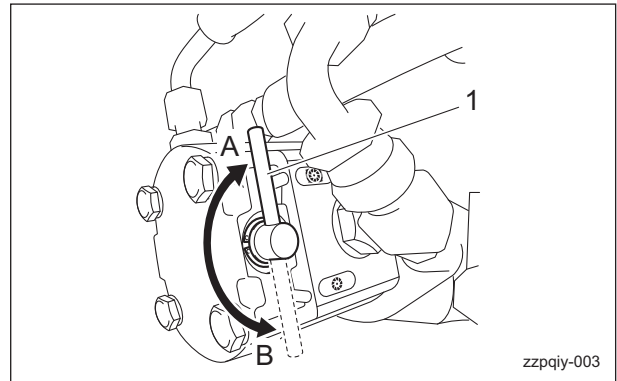

Reel Rotation/Stop Switching Lever_001

1	Reel rotation/stop switching lever
A	Rotation
B	Stop

Traveling Pedal

The traveling pedal is located in the right foot area. When the forward end is depressed, the machine travels forward. When the backward end is depressed, the machine travels backward.

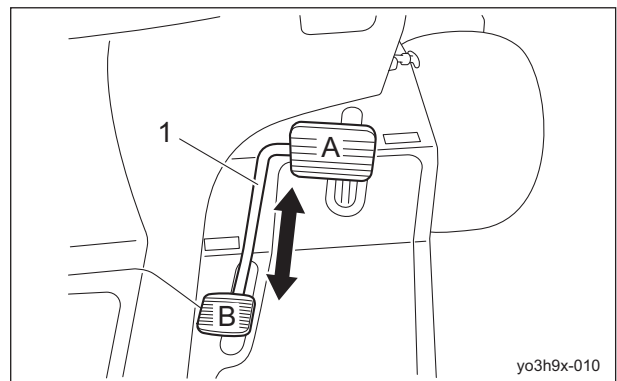

Traveling Pedal_001

1	Traveling pedal
A	Forward
B	Backward

Description of Functions

Brake Pedal

The brake pedal is located in the left foot area. To stop the machine, firmly depress the brake pedal.

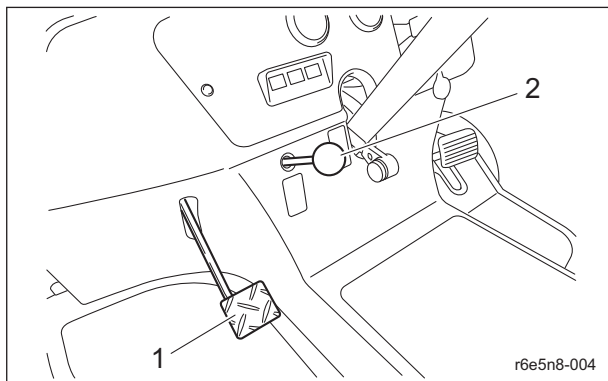

Brake Pedal_001

1	Brake pedal
2	Parking brake lever

Parking Brake Lever

Caution

Never park the machine on a slope.

Important

Be sure to release the parking brake before driving. Otherwise, the brakes or hydraulic system will malfunction.

The parking brake lever is located under the left side of the meter panel.

To park the machine, depress the brake pedal and pull the parking brake lever completely.

To release the parking brake, depress the brake pedal again.

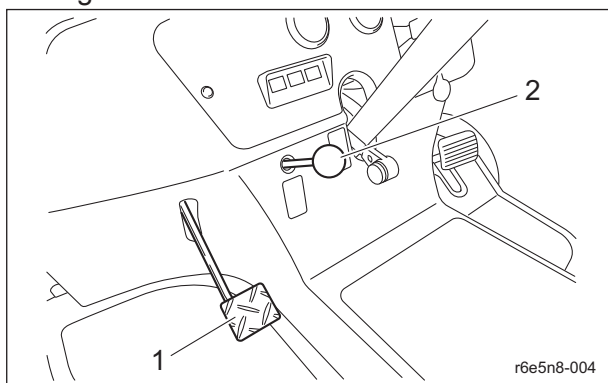

Parking Brake Lever_001

1	Brake pedal
2	Parking brake lever

Battery Cutoff Switch

Important

After disconnecting, switch the ignition key to the "ON" position and check that the charge lamp and oil pressure lamp do not turn on.

The battery cutoff switch is located on top of the battery (behind the driver's seat, on the left). This switch connects and disconnects the negative battery cable.

When the knob is tightened to set the switch to the "ON" position, the negative battery cable is connected. When knob is loosened to set the switch to the "OFF" position, the negative battery cable is disconnected.

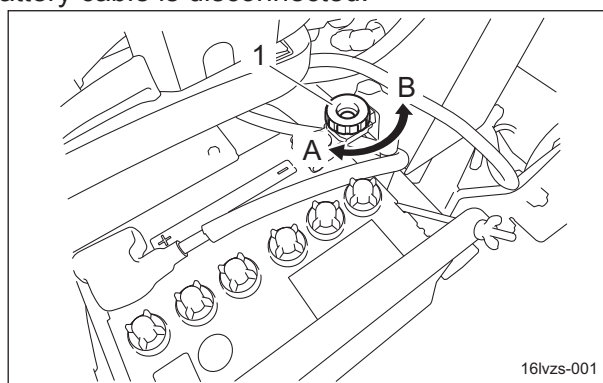

Battery Cutoff Switch_001

1	Battery cutoff switch
A	ON (connect)
B	OFF (disconnect)

Description of Functions

Instruments in the Meter Panel

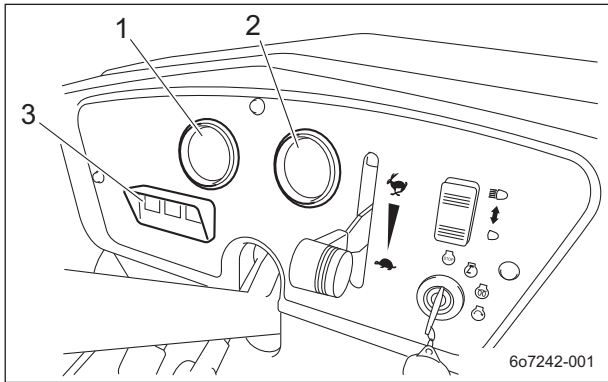

Instruments in the Meter Panel_001

1	Water temperature gauge
2	Fuel gauge
3	Pilot lamps (charge lamp, thermo-start lamp, and oil pressure lamp)

Fuel Gauge

The fuel gauge is located in the meter panel. This instrument indicates the quantity of fuel inside the fuel tank.

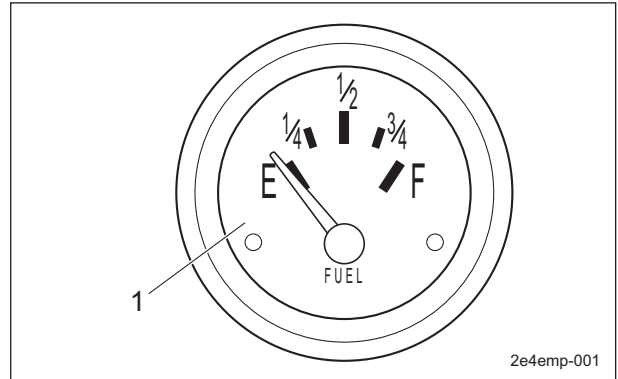

Fuel Gauge_001

1	Fuel gauge
---	------------

Pilot Lamps

Charge Lamp

The charge lamp is the left pilot lamp, located in the meter panel. This lamp turns on when the ignition key is set to the "ON" position before the engine starts. It turns off when the engine starts and the alternator starts operating properly. If this lamp illuminates while you are operating the machine, stop the engine immediately, and then inspect the machine and perform any necessary maintenance.

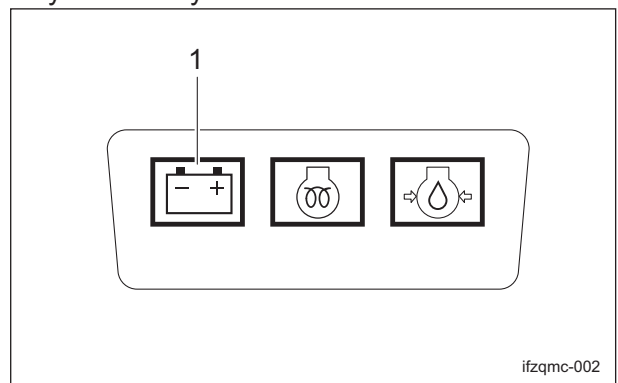

Charge Lamp_001

1	Charge lamp
---	-------------

Water Temperature Gauge

The water temperature gauge is located in the meter panel. This instrument indicates the water temperature inside the engine. If the water temperature gauge indicates a level close to "H" during operation, the machine is overheated. Remove the load from the engine, idle the machine for five minutes, stop the engine, and then inspect the machine and perform any necessary maintenance. If the water temperature exceeds 105 degrees Celsius, a buzzer will sound. (intermittent tone)

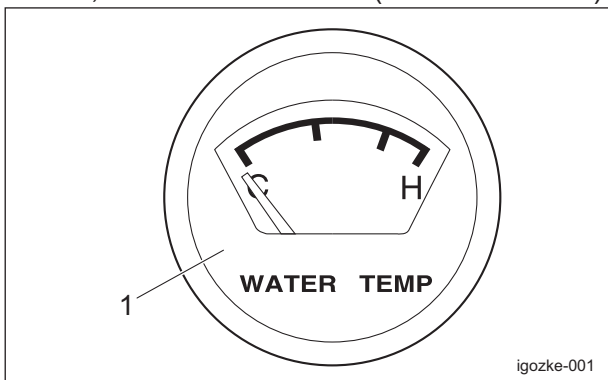

Water Temperature Gauge_001

1	Water temperature gauge
---	-------------------------

Description of Functions

Thermo-start Lamp

The thermo-start lamp is the middle pilot lamp, located in the meter panel. When the ignition key is set to the "GLOW" position, this lamp turns on while the glow plug generates heat.

Illumination of the thermo-start lamp is controlled by the glow lamp timer, and the lamp is turned off after a specified amount of time passes.

The duration of illumination indicates an approximate period of time required for warm-up, and has been fixed at five seconds.

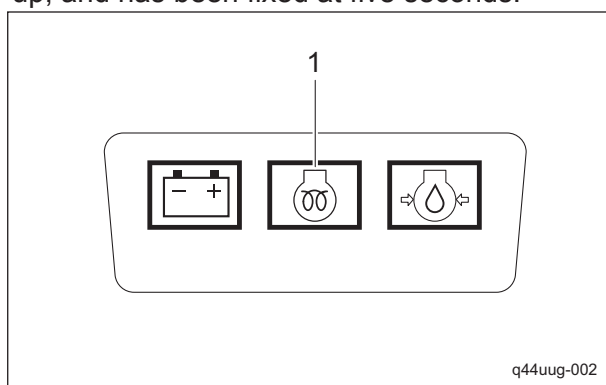

Thermo-start Lamp_001

1	Thermo-start lamp
---	-------------------

Oil Pressure Lamp

The oil pressure lamp is the right pilot lamp, located in the meter panel.

This lamp turns on when the ignition key is set to the "ON" position before the engine starts. It turns off when the engine starts and engine oil pressure is generated properly.

If this lamp illuminates while you are operating the machine, stop the engine immediately, and then inspect the machine and perform any necessary maintenance.

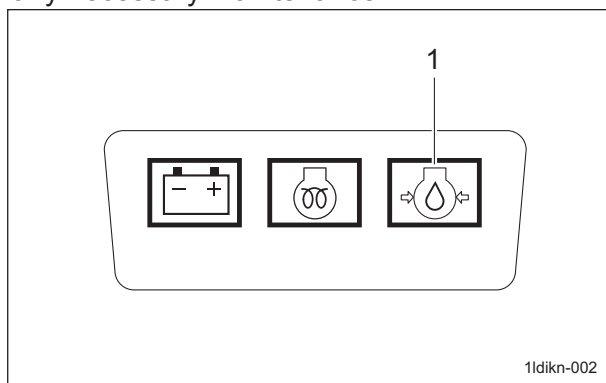

Oil Pressure Lamp_001

1	Oil pressure lamp
---	-------------------

Overheat Warning Buzzer

If the water temperature inside the engine exceeds 105 °C (221 °F), a buzzer will sound. (intermittent tone)

Remove the load from the engine, idle the machine for five minutes, stop the engine, and then inspect the machine and perform any necessary maintenance.

Hour Meter

The hour meter indicates the accumulated operation time of the engine.

The number in red figures on a white background is incremented every thirty-six seconds.

The number in white figures on a black background is incremented every hour. 1/100 wheel ... red figures on a white background

Hour wheel ... white figures on a black background

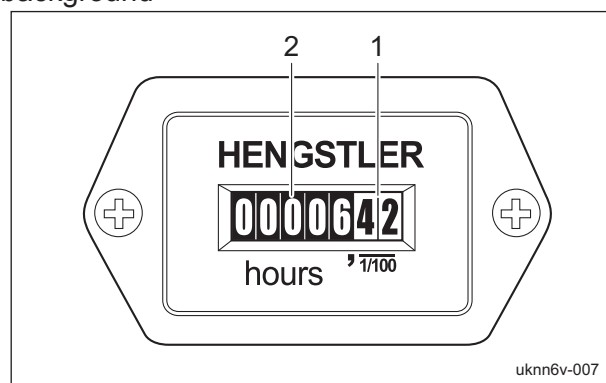

Hour Meter_001

1	1/100 wheel
2	Hour wheel

Description of Functions

Safety Mechanisms

This machine features a safety device for starting/stopping the engine.

1. As for starting the engine, the safety device prevents the engine from starting unless it meets each of the following four conditions.
 - An operator is sitting on the seat.
 - The parking brake is applied.
 - The reel rotation switch is set to the "OFF" position.
 - The traveling pedal is set to the neutral position.
2. In the event the operator leaves the seat with the parking brake applied and the engine running, the safety device will be activated and will stop the engine under any of the following conditions:
 - The traveling pedal is not set to the neutral position. (The operator has depressed the traveling pedal.)
 - The reel rotation switch is set to the "Rotate" position.

However, when the reel reverse switch is set to the "ON" position (reverse rotation), the engine does not stop.

Warning Mechanisms

 **Caution**

When the buzzer (intermittent tone) sounds, be sure to stop operation since the engine is overheated.

Do not stop the engine without idling. Allow the engine to cool down, first.

Keep the engine idling for about 5 minutes before stopping.

Remove dust that is jamming in the radiator, air cleaner, and etc.

This machine features a warning mechanism for overheating.

1. Overheat Warning Buzzer

If water temperature inside the engine exceeds 105 °C (221 °F), a buzzer will sound. (intermittent tone)

Remove the load from the engine, idle the machine for five minutes, stop the engine, and then inspect the machine and perform any necessary maintenance.

Handling Instructions

Operations Before Service	Page 5-2	Traveling Procedure	Page 5-19
Opening and Closing of Hood	Page 5-2	Cutting Work	Page 5-20
Removing and Installing of Rear Cover	Page 5-2	Cutting Work	Page 5-20
Removing and Installing of Center Cover	Page 5-3	Removal/Installation of Grass Catcher	Page 5-20
Inspection and Cleaning	Page 5-4	Transporting	Page 5-21
Radiator	Page 5-4	Transporting Procedure	Page 5-21
Coolant	Page 5-4		
Oil Cooler	Page 5-6		
Hydraulic Oil	Page 5-6		
Hydraulic Hoses	Page 5-8		
Air Cleaner	Page 5-8		
Battery	Page 5-9		
Electrical Wiring	Page 5-10		
Tire	Page 5-10		
Brake	Page 5-10		
Belt	Page 5-11		
Wire	Page 5-11		
Safety Device	Page 5-11		
Around The Engine	Page 5-11		
Engine Oil	Page 5-11		
Fuel	Page 5-12		
Water Separator	Page 5-13		
Fuel Filter	Page 5-15		
Liquid Leakage	Page 5-15		
Bolts and Nuts	Page 5-16		
Grass Catcher	Page 5-16		
Adjustment before Work	Page 5-16		
Adjustment of Steering Wheel	Page 5-16		
Adjustment of Seat	Page 5-17		
Start/Stop of Engine	Page 5-17		
Procedure to Start Engine	Page 5-17		
Procedure to Stop Engine	Page 5-19		
Parking and Stopping	Page 5-19		
Leaving the machine	Page 5-19		
Move	Page 5-19		

Handling Instructions

Operations Before Service

Opening and Closing of Hood

Caution

Do not open the hood in strong winds.

Caution

Be careful not to pinch your fingers when you open or close the hood.

Important

Before opening the hood, be sure to lower the mower units.
In addition, do not raise the mower units while the hood is open.
Otherwise, the hood will be damaged.

1. Loosen the lock bolt for the hood.

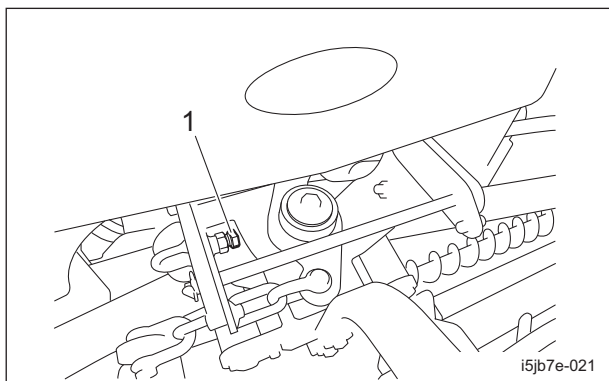

Opening and Closing of Hood_001

1	Lock bolt
---	-----------

2. Release the rubber catches on the left and right sides.

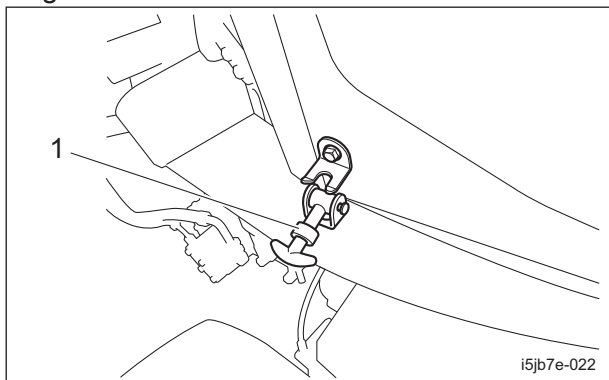

Opening and Closing of Hood_002

1	Rubber catch
---	--------------

3. Lift up the hood.

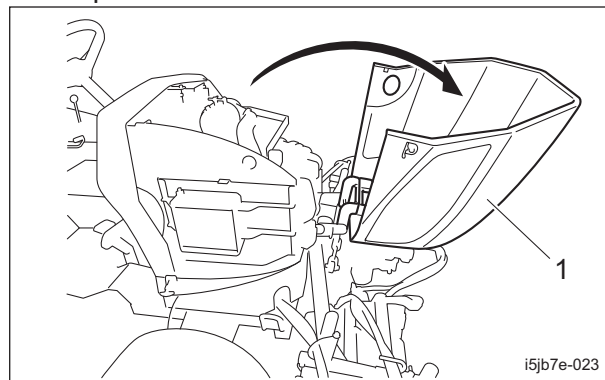

Opening and Closing of Hood_003

1	Hood
---	------

4. Close the hood slowly.

5. Hook the rubber catches without fail.

6. Tighten the lock bolt for the hood.

Removing and Installing of Rear Cover

Caution

Do not remove the rear cover in strong winds.

Caution

Be careful not to pinch your fingers when removing or installing the rear cover.

1. Remove the bolts on the rear cover.

Left and right mounting bolts (one each)

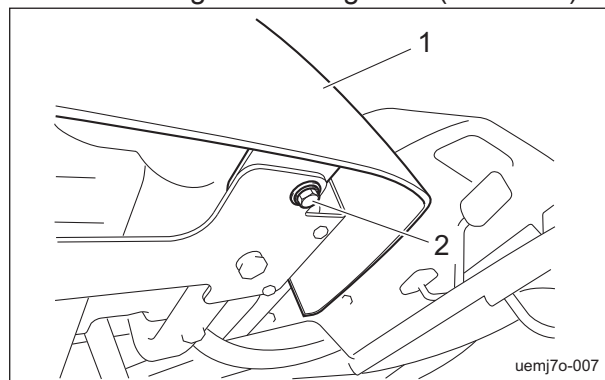

Removing and Installing of Rear Cover_001

1	Rear cover
2	Bolt

Handling Instructions

Rear mounting bolts (two)

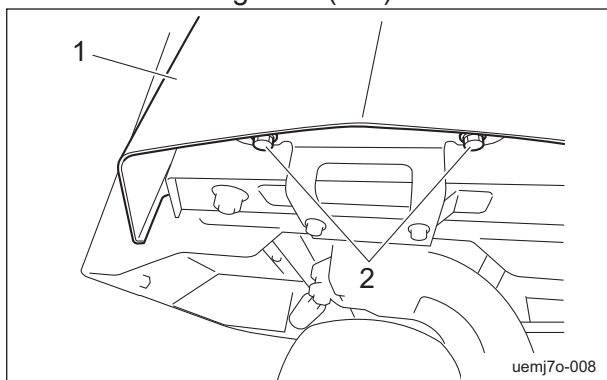

Removing and Installing of Rear Cover_002

1	Rear cover
2	Bolt

2. Bring the seat to the very front position.
3. If the ROPS or the ball proof net is installed, follow the steps below to fold back the ROPS.

[1] Remove the clip pins on the left and right sides of the ROPS, and then remove the lock pins.

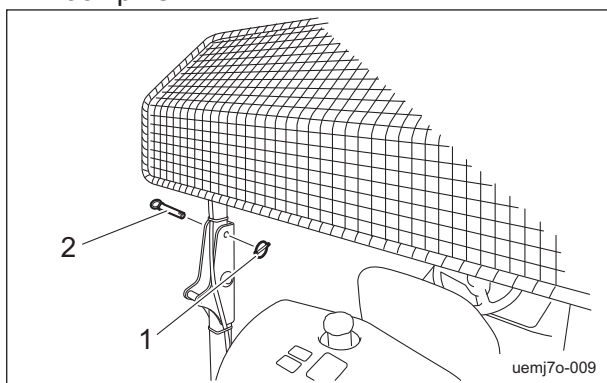

Removing and Installing of Rear Cover_003

1	Clip pin
2	Lock pin

[2] Fold back the ROPS.

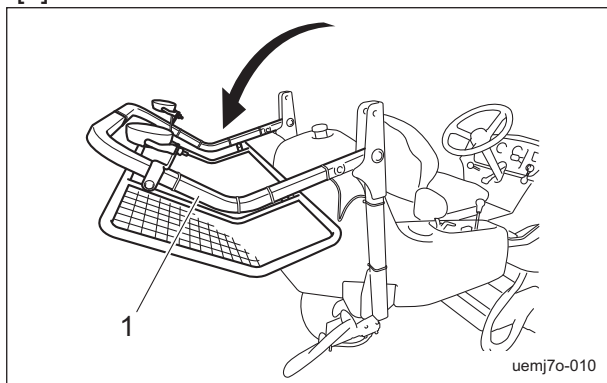

Removing and Installing of Rear Cover_004

1	ROPS
---	------

4. Pull up the rear cover to remove it.

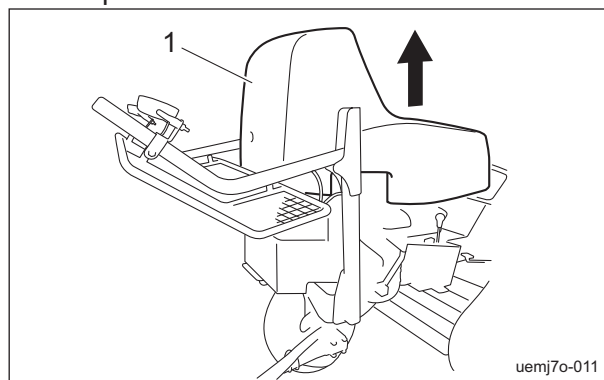

Removing and Installing of Rear Cover_005

1	Rear cover
---	------------

5. For installing the rear cover, reverse the removing procedure.

Removing and Installing of Center Cover

1. Removing procedure :

- [1] Bring the seat to the backmost position.
- [2] Completely raise the steering wheel.
- [3] Remove the bolt on each side of the center cover.
- [4] Remove the center cover.

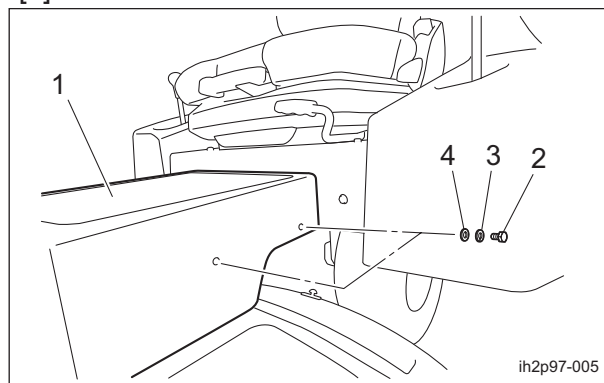

Removing and Installing of Center Cover_001

1	Center cover
2	Bolt
3	Spring washer
4	Washer

2. Installing procedure :

- [1] Bring the seat to the backmost position.
- [2] Completely raise the steering wheel.
- [3] Install the center cover with the bolts.

Handling Instructions

Inspection and Cleaning

Radiator

Inspection of Radiator

1. Make sure that there is no damage to the radiator.
2. Make sure that the radiator is not contaminated.

Cleaning of Radiator

Important

An unclean radiator may cause the engine to overheat or seize. It may also cause malfunction of the hydraulic system.

Important

Do not use solid objects, such as a spatula or screwdriver, or high-pressure water to clean the radiator or oil cooler. Otherwise, special fins or tubes may be damaged, possibly resulting in reduced cooling performance or coolant leakage.

1. Open the hood.
"Opening and Closing of Hood" (Page 5-2)
2. Pull up the dust screen to remove it.

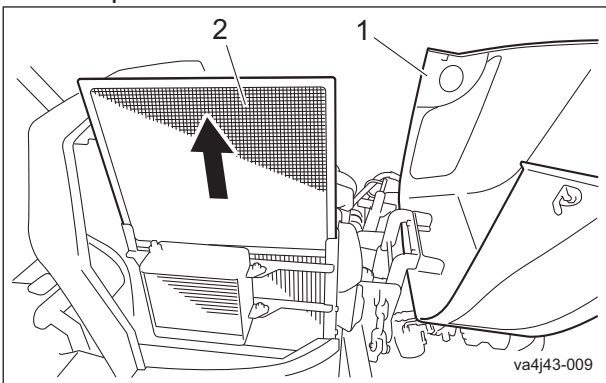

Cleaning of Radiator_001

1	Hood
2	Dust screen

3. Carefully clean the front and back of the dust screen and radiator with water or compressed air.

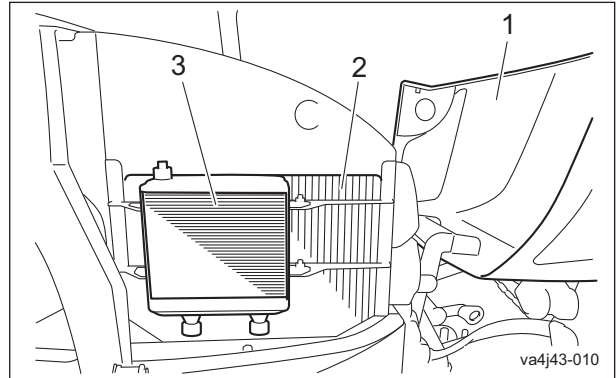

Cleaning of Radiator_002

1	Hood
2	Radiator
3	Oil cooler

Coolant

Inspection of Coolant

Caution

Do not touch the radiator or coolant during engine operation or immediately after the engine has been turned off. Otherwise, you may get burned.

Caution

Inspection should take place after the engine has well cooled down.

1. Make sure that the coolant level in the reserve tank is between "FULL" and "LOW."

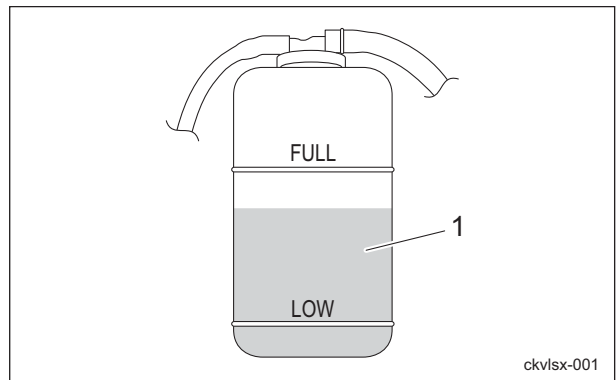

Inspection of Coolant_001

1	Reserve tank
---	--------------

Handling Instructions

Coolant Supply

⚠ Caution

Do not touch the radiator or coolant during engine operation or immediately after the engine has been turned off. Otherwise, you may get burned due to high temperatures.

⚠ Caution

Supply coolant after the engine has well cooled down.

⚠ Caution

The radiator cap is pressurized. If you remove the radiator cap while the engine is overheated, hot steam will burst out, possibly resulting in burns. Make sure that the water temperature and pressure are reduced, and then grab the cap with a thick cloth and gradually open the cap.

Important

When you supply coolant, be sure to use clean water, such as tap water.

Important

Tightly close the radiator cap. If the cap is loose or incorrectly installed, the engine will be overheated due to water leakage, resulting in engine damage.

1. If the coolant level in the reserve tank is lower than the "LOW" mark, open the reserve tank cap and fill the tank with clean water up to the "FULL" mark.

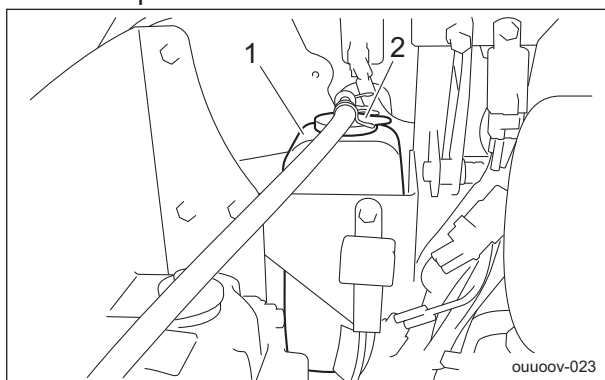

Coolant Supply_001

1	Reserve tank
2	Reserve tank cap

2. If no coolant is in the reserve tank, follow the steps below to fill the tank with clean water.

- [1] Open the radiator cap, and then supply clean water up to the opening.
- [2] Open the reserve tank cap, and then supply clean water up to the "FULL" mark.

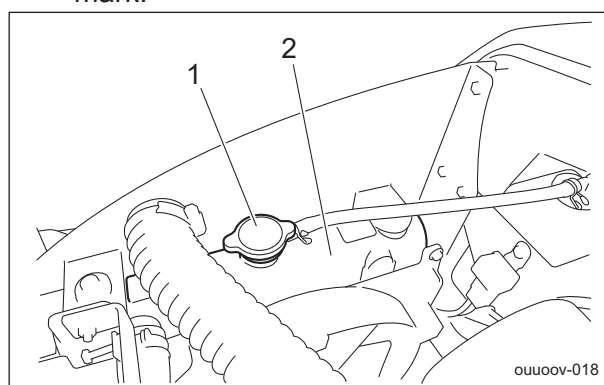

Coolant Supply_002

1	Radiator cap
2	Radiator

Handling Instructions

Oil Cooler

Inspection of Oil Cooler

1. Make sure that there is no damage to the oil cooler.
2. Make sure that the oil cooler is not contaminated.

Cleaning of Oil Cooler

Important

An unclean oil cooler may cause malfunction of the hydraulic system.

Important

Do not use solid objects, such as a spatula or screwdriver, or high-pressure water to clean the radiator or oil cooler. Otherwise, special fins or tubes may be damaged, possibly resulting in reduced cooling performance or coolant leakage.

If the oil cooler has been contaminated with dust, be sure to clean it. Especially after operating the machine in a dusty environment, it is important to remove dust as soon as possible.

1. Open the hood.
"Opening and Closing of Hood" (Page 5-2)
2. Carefully clean the front and back of the oil cooler with water or compressed air.

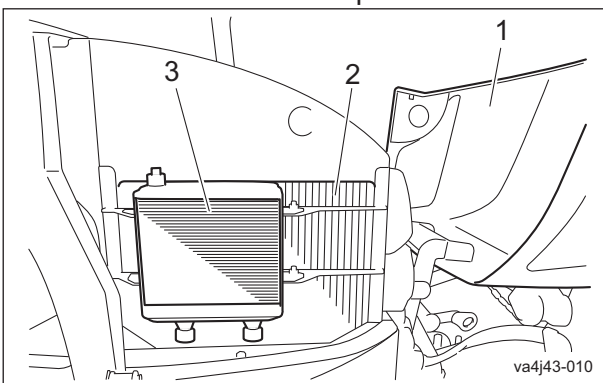

Cleaning of Oil Cooler_001

1	Hood
2	Radiator
3	Oil cooler

Hydraulic Oil

Inspection of Hydraulic Oil

The oil gauge is located on the back of the hydraulic tank.

1. Raise the mower units and maintain that position on a level surface.
2. Make sure that the oil level is at the middle of the oil gauge.

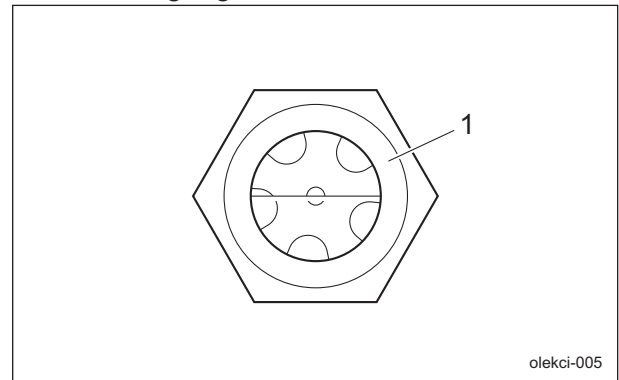

olekci-005

Inspection of Hydraulic Oil_001

1	Oil gauge
---	-----------

3. Check underneath the machine for hydraulic oil leakage.

Handling Instructions

Hydraulic Oil Supply

Important

Do not mix different types of oil.

Important

Use Shell Tellus S2M46 (or equivalent) as hydraulic oil.
In case of an equivalent, consult Characteristics of Hydraulic Oil and use hydraulic oil whose characteristics are superior to those of the specific hydraulic oil. Especially regarding kinematic viscosity and viscosity index, use of hydraulic oil whose figures are less than those of the specified hydraulic oil will cause a malfunction in the hydraulic circuit.

Note:

Characteristics of Hydraulic Oil

Specified Hydraulic Oil		Shell Tellus S2M46
ISO Viscosity Grade		ISO VG46
Density	15 °C (59 °F)	0.873 g/cm ³ (0.0315 lb/in ³)
API Gravity		30.6
Flash Point (Open Cup)		230 °C (446 °F)
Pour Point		-30 °C (-22 °F)
Kinematic	40 °C (104 °F)	46 mm ² /s (46 cSt)
Viscosity	100 °C (212 °F)	7 mm ² /s (7 cSt)
Viscosity Index		109

1. Remove the rear cover.
"Removing and Installing of Rear Cover"
(Page 5-2)
2. If the hydraulic oil level is low, follow the steps below to supply oil.
 - #10001-10278
 - [1] Open the tank cap.
 - [2] Supply hydraulic oil through the oil filling port until the oil level reaches the middle of the oil gauge on the hydraulic tank.

- [3] Tighten the tank cap securely.

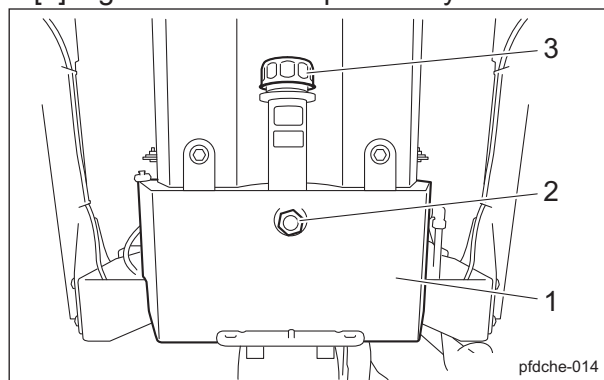

Hydraulic Oil Supply_001

1	Hydraulic tank
2	Oil gauge
3	Tank cap

■ #10279-

- [1] Loosen the bushing with a wrench and remove the oil filler plug.
- [2] Supply hydraulic oil through the oil filling port until the oil level reaches the middle of the oil gauge on the hydraulic tank.
- [3] Install the oil filler plug and tighten the bushing securely.

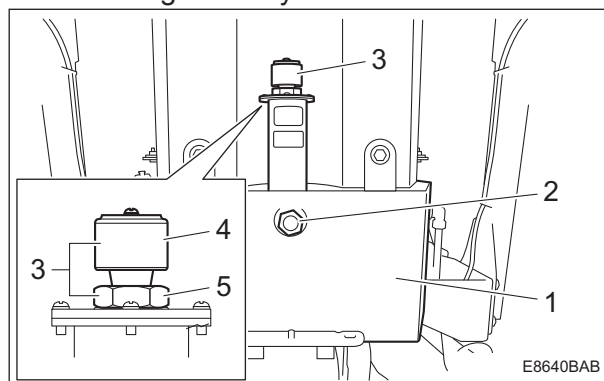

Hydraulic Oil Supply_002

1	Hydraulic tank
2	Oil gauge
3	Oil filler plug
4	Air breather
5	Bushing

3. Start the engine, raise and lower the mower units, and turn the steering wheel left and right.
Move forward and reverse repeatedly several times.
4. Raise the mower units and maintain that position on a level surface, and then check to see if the oil level is at the middle of the oil gauge. If necessary, supply oil.

Handling Instructions

5. Check underneath the machine for hydraulic oil leakage.
6. Install the rear cover.

Hydraulic Hoses

Inspection of Hydraulic Hoses

Warning

When checking the hydraulic circuit for pinhole leaks or oil leakage from nozzles, do not use your hands. Use items such as paper or corrugated cardboard to find leakage points.

Be extremely careful with high-pressure oil as it may pierce your skin, resulting in personal accidents.

If fluid is injected into the skin it must be surgically removed within a few hours by a doctor familiar with this form of injury or gangrene may result.

Check the pipes and hoses to make sure that there is no oil leakage, circuit damage, looseness, wear, connector looseness, weather deterioration and chemical deterioration.

Make any necessary repairs before operating the machine.

Air Cleaner

Inspection of Air Cleaner

The air cleaner is a component that removes dirt from the intake air to prevent wear of the cylinder liners and piston rings so that the engine will always operate smoothly.

A contaminated air cleaner element may cause malfunction of the engine.

1. Make sure that there is no damage to the air cleaner.

2. Make sure that the air cleaner element is not contaminated.

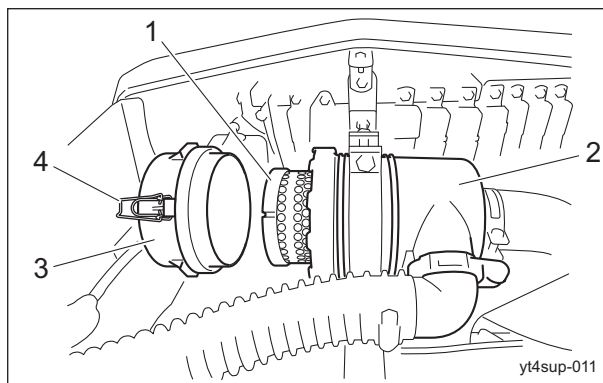

Inspection of Air Cleaner_001

1	Air cleaner element
2	Air cleaner body
3	Air cleaner cap
4	Clip

Handling Instructions

Cleaning of Air Cleaner

A contaminated air cleaner element may cause malfunction of the engine. To maximize the life of the engine, clean the air cleaner properly.

1. Follow the steps below to clean the air cleaner.
 - [1] Unclip at two locations to remove the air cleaner cap, and then remove the air cleaner element.
 - [2] While paying close attention not to damage the air cleaner element, tap a solid portion of the air cleaner element or blow compressed air from its inside to remove dust and dirt. If the air cleaner element is extremely contaminated, replace it with a new one.
 - [3] Attach the air cleaner element to the air cleaner body.
 - [4] Attach the air cleaner cap, and then fix it securely with the clips.

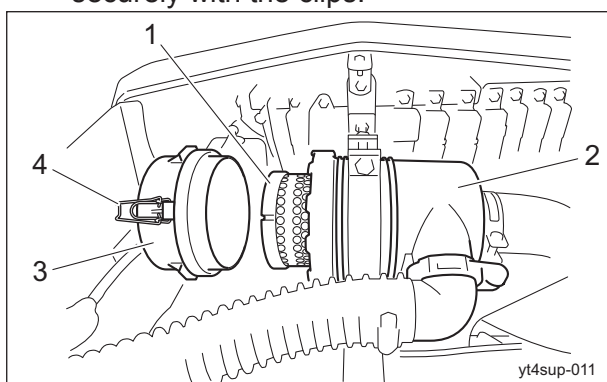

Cleaning of Air Cleaner_001

1	Air cleaner element
2	Air cleaner body
3	Air cleaner cap
4	Clip

Battery

Inspection of Battery

Danger

Keep fire away while inspecting or charging the battery. The battery may explode.

Warning

Do not allow the battery fluid level to become lower than the LOWER LEVEL (minimum fluid level line). The battery may explode if it is used or charged while the battery fluid level is at the LOWER LEVEL (minimum fluid level line).

1. Clean the areas around the battery fluid level lines using a cloth dampened with water.
2. Make sure that the battery fluid level is between the UPPER LEVEL (maximum fluid level line) and the LOWER LEVEL (minimum fluid level line).

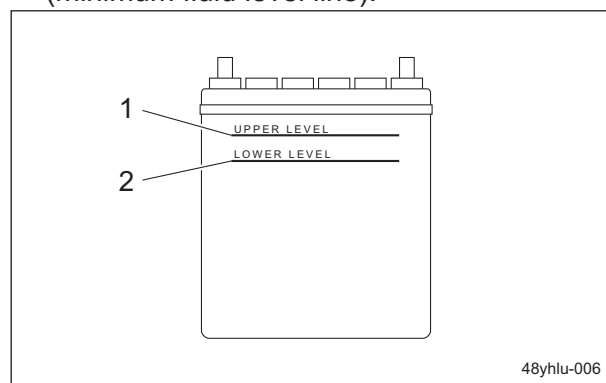

Inspection of Battery_001

1	UPPER LEVEL
2	LOWER LEVEL

Handling Instructions

Supply of Battery Fluid

Danger

Be careful not to let your skin, eyes or clothes, etc., come into contact with the battery fluid or accidentally swallow the fluid. Should your skin or clothes come into contact with the battery fluid, immediately wash them away with water.

Danger

When you supply battery fluid, wear protective garments and safety glasses, etc.

1. If the battery fluid level is lower than halfway between the UPPER LEVEL (maximum) line and LOWER LEVEL (minimum) line, add purified water up to the UPPER LEVEL (maximum) line.

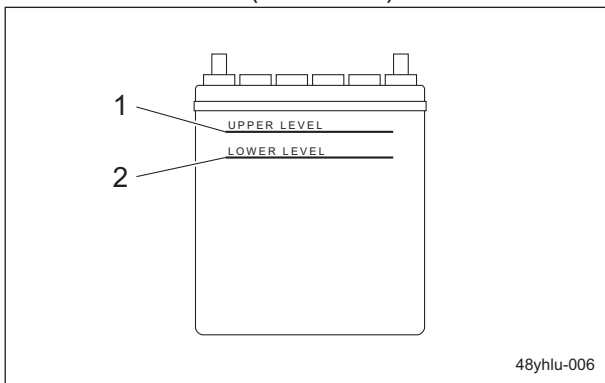

48yhlu-006

Supply of Battery Fluid_001

1	UPPER LEVEL
2	LOWER LEVEL

Electrical Wiring

Inspection of Electrical Wiring

Important

Electrical short circuit will cause fire, electrical leakage and malfunction of electrical equipments.

Inspect electrical wiring for poor terminal connections, damaged wiring or terminals, loose connections, weather-related deterioration and chemical-related deterioration.

If necessary, repair before operating the machine.

Tire

Inspection of Tires

1. Check the pneumatic pressure of the tires.
2. Make sure that there are no cracks, damage or abnormal wear.

	Tire size	Pneumatic pressure	
Front wheel	20 x 12.00-10	140 kPa (1.4 kgf/cm ²)	20 psi
Rear wheel	20 x 8.00-10	140 kPa (1.4 kgf/cm ²)	20 psi

Brake

Inspection of Brake Pedal

1. When depressing the brake pedal fully, make sure that there is appropriate clearance between the floorboard and the pedal or pedal reserve distance.
2. When depressing the brake pedal fully, make sure that the pedal reaction is not spongy and that there is no noise.
3. When depressing the brake pedal during traveling, make sure that the machine stops smoothly and the braking is sufficiently effective.

Inspection of Parking Brake

1. Depress the brake pedal and pull the parking brake lever to check that the parking brake is applied effectively.
2. Make sure that the brake is not applied even slightly after you depress the brake pedal to release the parking brake lever.

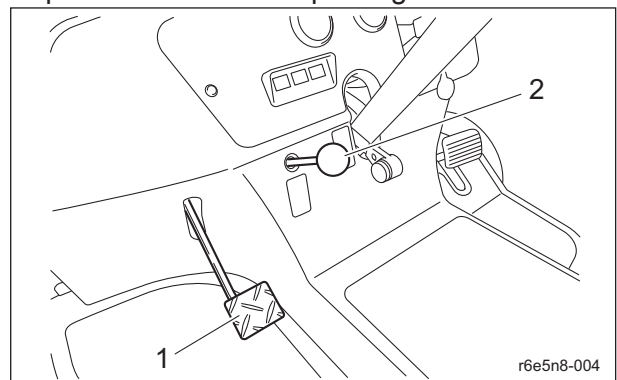

Inspection of Parking Brake 001

1	Brake pedal
2	Parking brake lever

Handling Instructions

Belt

Inspection of Belt

Warning

The engine must be stopped when the belt is inspected.

Warning

If you have removed the cover during inspection, make sure that you replace it in the original position securely.
If the cover remains removed, the operator may come in contact with the rotating objects or belt, possibly resulting in injuries.

Important

A slacking or damaged belt or damaged fan may cause overheating or lack of a battery charge.

1. Press the middle of the belt with your finger to check the belt tension.
2. Make sure that there are no cracks, damage or abnormal wear.

Wire

Inspection of Wire

1. Make sure that the wire is not cracked or damaged.
2. If the wire is cracked or damaged, replace it with a new one immediately.

Safety Device

Inspection of Safety Device

Make sure that the safety device operates correctly.

"Safety Mechanisms" (Page 4-8)

Around The Engine

Inspection of Engine-Associated Parts

Caution

Perform operations after the engine and other parts have sufficiently cooled.
Otherwise, you may suffer burns.

1. Check for damages and dirt.

2. Check the mount for looseness and cracks.
3. Check for liquid leakage.
4. Check on and around the muffler for grass clippings and flammable materials.

Cleaning Engine-Associated Parts

Caution

Perform operations after the engine and other parts have sufficiently cooled.
Otherwise, you may suffer burns.

1. Clean clippings and remove dirt.
2. Blow compressed air to clean any grass or flammable materials that may be attached on or around the muffler.

Engine Oil

Inspection of Engine Oil

Important

Securely tighten the oil level gauge and oil filler cap.

1. Stop the engine, wait for 10 to 20 minutes for the engine to cool down, and then check the oil level.
2. Position the machine so that the engine is level, and then fully insert the oil level gauge to check the oil level.

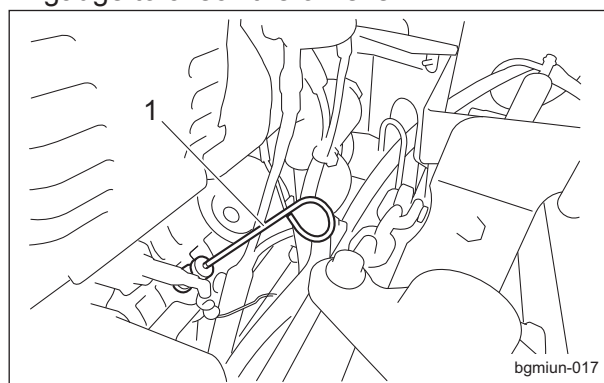

Inspection of Engine Oil_001

1 Oil level gauge

Handling Instructions

3. The appropriate oil level should be between the upper and lower limit lines on the gauge.

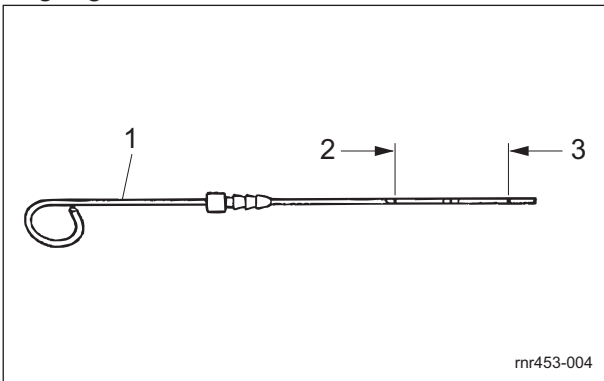

Inspection of Engine Oil_002

1	Oil level gauge
2	Upper limit
3	Lower limit

Supply of Engine Oil

Important

Do not supply too much engine oil. Otherwise, the engine may be damaged.

Important

Do not mix different types of engine oil.

Important

Be sure to use engine oil that is classified as API Service Grade CF or higher, with an SAE Viscosity that is appropriate for the operating environment (ambient temperature).

Important

Securely tighten the oil level gauge and oil filler cap.

1. Engine oil is supplied through the oil filler cap.
Remove the oil filler cap, and then supply new engine oil until the oil reaches a level in between the upper and lower limit lines on the oil level gauge.

2. Securely install the oil filler cap.

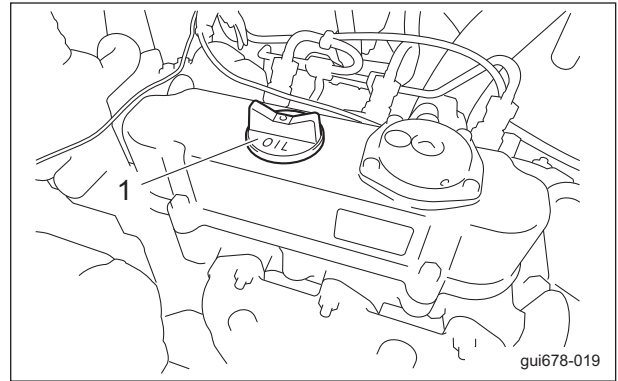

Supply of Engine Oil_001

1	Oil filler cap
---	----------------

3. It will take a while for the supplied engine oil to descend into the oil pan. Check the oil level again 10 to 20 minutes after supplying the oil.

Fuel

Inspection of Fuel Quantity

With the machine on a level surface, observe the fuel gauge in the meter panel to check the fuel level.

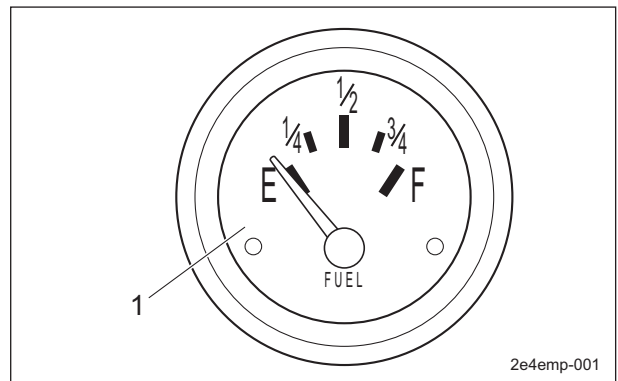

Inspection of Fuel Quantity_001

1	Fuel gauge
---	------------

Handling Instructions

Supply of Fuel

Warning

Do not supply fuel above F (FULL) level of the fuel gauge.
If you supply too much fuel, it might overflow from the cap when you travel or work on a slope.

Warning

Keep away from fire while refueling.
Do not smoke while refueling.

If the fuel gauge in the meter panel indicates a level close to E (EMPTY), supply fuel (diesel) at your earliest convenience. The fuel tank capacity is approximately 25.0 dm³ (25.0 L).

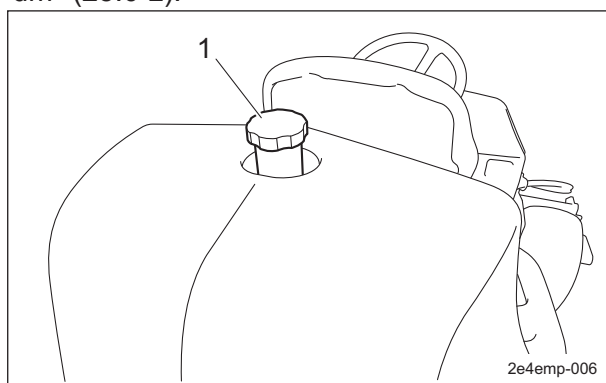

Supply of Fuel_001

1	Tank cap
---	----------

Water Separator

Inspection of Water Separator

Important

Water-contaminated fuel may impair engine startability, decrease output or damage engine parts.

The water separator removes water from the fuel.

1. Make sure that debris and water have not accumulated in the cup.
With the float raised, water contamination is confirmed.
When the float reaches the drain level, drain the water.

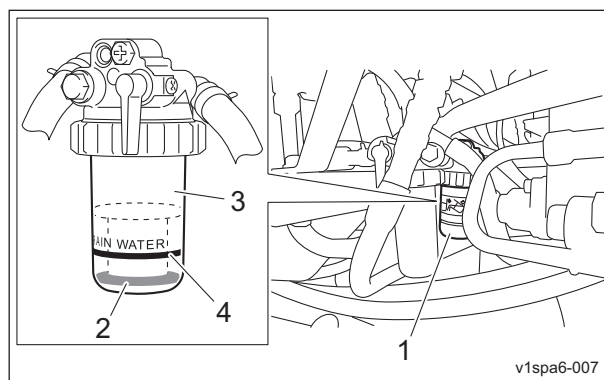

Inspection of Water Separator_001

1	Water Separator
2	Float
3	Cup
4	Drain level

Draining of Water Separator

Important

Water-contaminated fuel may impair engine startability, decrease output or damage engine parts.

Drain water from the water separator according to the maintenance schedule. And drain water whenever the float is raised by water.

1. Stop the engine, and then turn the key switch to the "OFF" position.
2. Place a container under the water separator.
3. Close the fuel cock of the fuel filter.
4. Close the fuel cock of the water separator.

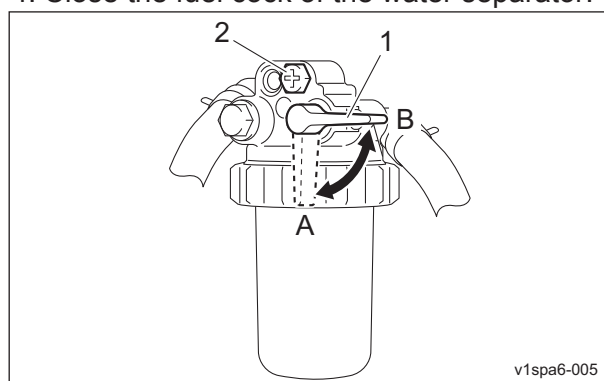

Draining of Water Separator_001

1	Fuel cock
2	Air-bleeding plug
A	ON (open)
B	OFF (close)

Handling Instructions

5. Remove the ring nut, and then remove the cup.

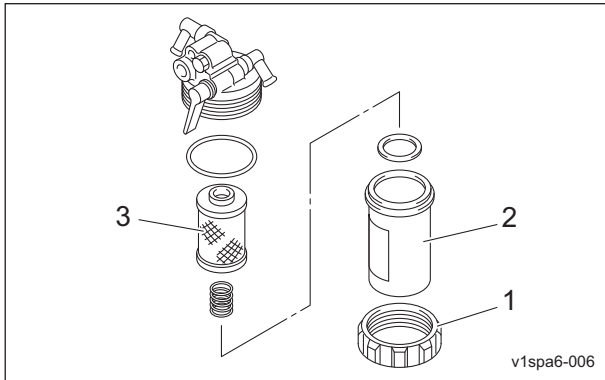

Draining of Water Separator_002

1	Ring nut
2	Cup
3	Element

6. Drain the water from the cup.

Important

During installation, prevent contamination with dirt or dust.

If the fuel is contaminated with dirt or dust etc., the fuel injection pump and injection nozzle will become worn.

7. Correctly install all parts in their original positions.
 8. Fill up the fuel tank with fuel, and then open the fuel cock of the fuel filter.
 9. Open the fuel cock of the water separator.

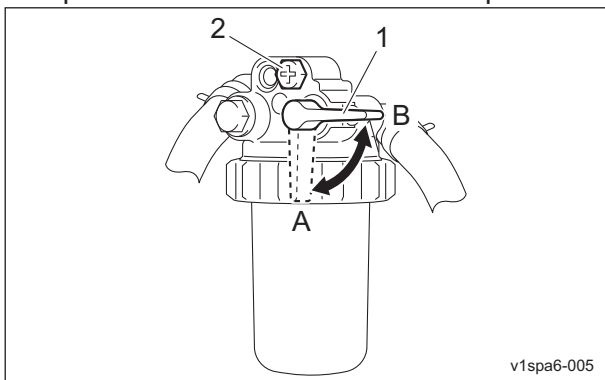

Draining of Water Separator_003

1	Fuel cock
2	Air-bleeding plug
A	ON (open)
B	OFF (close)

10. Loosen the air-bleed plug to bleed the air.
 11. When the cup is filled with fuel, close the air-bleed plug.

12. If the engine does not start within 15 seconds after switching the ignition key to the "START" position, wait at least 30 seconds, and then repeat the same operation.
 If there is still air in the cup after starting the engine, bleed the air again.

Cleaning of Water Separator

Important

Water-contaminated fuel may impair engine startability, decrease output or damage engine parts.

Clean the water separator according to the maintenance schedule.

And clean it whenever debris has accumulated in the cup.

1. Stop the engine, and then turn the key switch to the "OFF" position.
2. Place a container under the water separator.
3. Close the fuel cock of the fuel filter.
4. Close the fuel cock of the water separator.

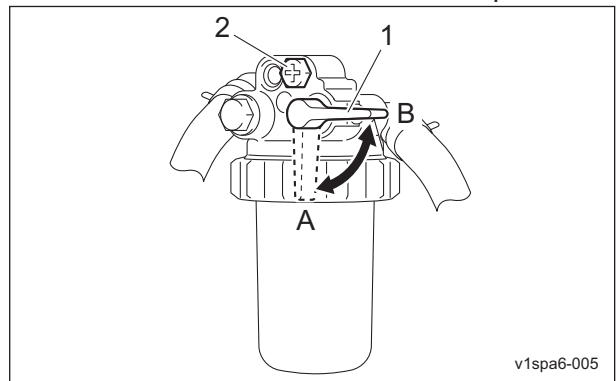

Cleaning of Water Separator_001

1	Fuel cock
2	Air-bleeding plug
A	ON (open)
B	OFF (close)

Handling Instructions

5. Remove the ring nut, and then remove the cup.

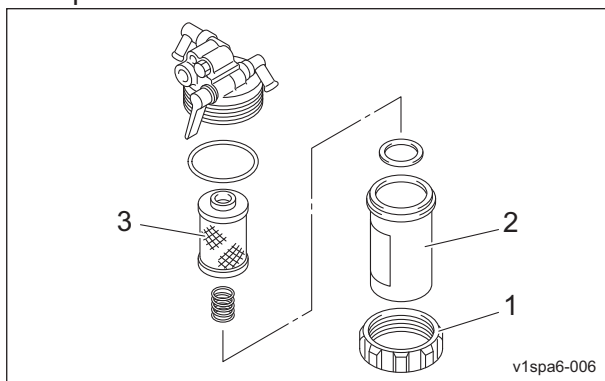

Cleaning of Water Separator_002

1	Ring nut
2	Cup
3	Element

6. Drain the water from the cup.
7. Clean the cup and element with diesel fuel.

Important

During installation, prevent contamination with dirt or dust.

If the fuel is contaminated with dirt or dust etc., the fuel injection pump and injection nozzle will become worn.

8. Correctly install all parts in their original positions.
9. Fill up the fuel tank with fuel, and then open the fuel cock of the fuel filter.
10. Open the fuel cock of the water separator.

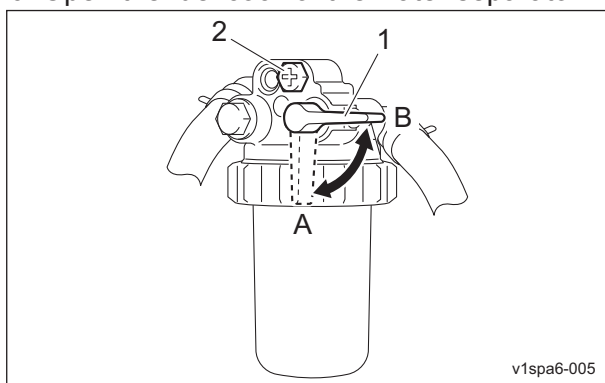

Cleaning of Water Separator_003

1	Fuel cock
2	Air-bleeding plug
A	ON (open)
B	OFF (close)

11. Loosen the air-bleed plug to bleed the air.

12. When the cup is filled with fuel, close the air-bleed plug.

13. If the engine does not start within 15 seconds after switching the ignition key to the "START" position, wait at least 30 seconds, and then repeat the same operation.

If there is still air in the cup after starting the engine, bleed the air again.

Fuel Filter

Inspection of Fuel Filter

The fuel filter works to remove foreign objects mixed into the fuel.

When the fuel flow becomes insufficient, replace the fuel filter if necessary.

1. Make sure that there is no fuel leakage.
2. Make sure that the fuel filter is not damaged or dirty.

Liquid Leakage

Inspection of Liquid Leakage

Caution

When performing maintenance on the hydraulic system, lower the mower units.

Important

After approximately 50 hours of operation, some tightened portions may be loosened and liquid such as oil may leak.

Be sure to retighten the parts.

1. Check the bottom of the machine for leakage of liquid such as oil, water, fuel, etc.
2. Locate the leakage and identify the type of liquid.
Ignoring leakage will cause further trouble.

Handling Instructions

Bolts and Nuts

Inspection of Bolts and Nuts

Important

A number of bolts are used in each part of this machine.

Be sure to re-tighten the bolts and nuts, because they may be loosened at the earlier stage of the use.

1. Check the bolts and nuts for looseness and coming off.
2. Check the bolts and nuts for cracks and damages.
3. Check the bolts and nuts for rust.
4. Check around the bolts and nuts for traces of rust fluid.
5. Check for unequal bolt length.
6. Check the bolts and nuts for stripped threads and abrasion.

Inspection of Wheel Mounting Bolt

Important

Tighten the wheel mounting bolts on the specified torque by using a torque wrench.

1. Check the wheel mounting bolts and wheel nuts for looseness and coming off.
2. Check the wheel mounting bolts and wheel nuts for cracks and damages.
3. Check the wheel mounting bolts and wheel nuts for rust.
4. Check around the wheel mounting bolts and wheel nuts for traces of rust fluid.
5. Check the wheel mounting bolts for unequal bolt length.
6. Check the wheel mounting bolts and wheel nuts for stripped threads and abrasion.

Grass Catcher

Inspection of Grass Catcher

The grass catcher may no longer correctly collect grass clippings due to its wear, damage, deformation, etc., caused by frequent use.

1. Make sure that there is no wear or deterioration of the grass catcher.
2. Make sure that there is no damage to the grass catcher.
3. Make sure that there is no interference to moving parts due to deformation of the grass catcher.

Adjustment before Work

Adjustment of Steering Wheel

Warning

Do not make adjustments while traveling since doing so is dangerous.

Caution

Be sure the steering wheel position is securely locked. It may result in an unexpected accident if it becomes loose while traveling.

The steering wheel can be adjusted up or down.

Adjust the position to fit the operator.

Shift the tilt lever to the "FREE" position, move the steering wheel to the position that suits the work requirements, and then shift the tilt lever to the "LOCK" position to secure the steering wheel in place.

The tilt lever is located at the left in front of the driver's seat.

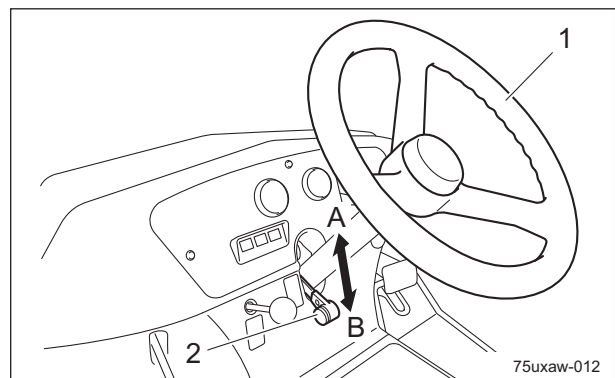

Adjustment of Steering Wheel_001

Handling Instructions

1	Steering wheel
2	Tilt lever
A	FREE (released)
B	LOCK (locked)

Adjustment of Seat

Use the seat adjustment levers to adjust the seat.

Adjust the position to fit the operator.

1. Use the forward/backward adjustment lever to adjust the seat back and forth.
2. Use the backrest tilt adjustment lever to adjust the angle of the backrest.
3. Pull out the suspension adjustment handle and move it up or down to adjust the firmness of the seat suspension.

Observe the suspension adjustment scale while making adjustments. [50 - 160 kg (110.2 - 352.7 lb)]

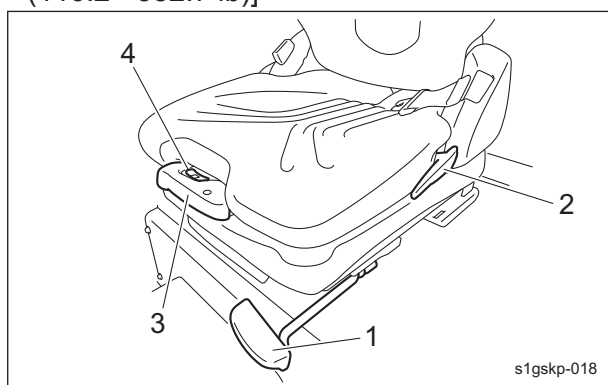

Adjustment of Seat_001

1	Forward/backward adjustment lever
2	Angle adjustment lever
3	Suspension adjustment handle
4	Suspension adjustment scale

Start/Stop of Engine

Procedure to Start Engine

⚠ Caution

Before starting the engine, make sure that there are no other people or obstacles around the machine.

⚠ Caution

Starter operation must take 15 seconds or less.

If the engine still does not start, stop using the battery for 30 to 60 seconds to avoid exhausting the battery.

1. Open the fuel cock of the water separator.
2. Open the fuel filter cock.

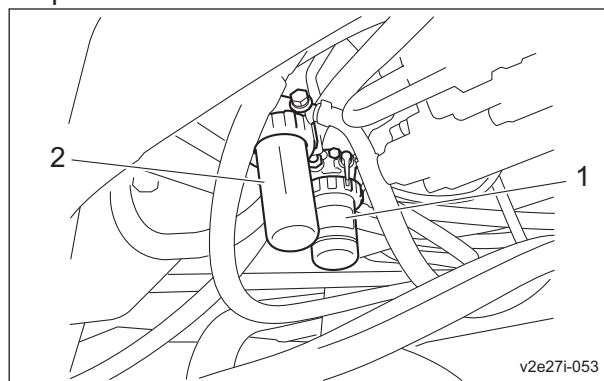

Procedure to Start Engine_001

1	Water Separator
2	Fuel filter

3. Sit on the seat.
4. Make sure that you have depressed the brake pedal and applied the parking brake.
5. Set the reel rotation switch to the "Stop" position.
6. Move the mower unit up/down lever to the neutral position.
7. Make sure that the traveling pedal is in the neutral position.
8. Shift the throttle lever from the "Low speed" position halfway to the "High speed" position.

Handling Instructions

Important

The thermo-start lamp turns off at the specified time. However, the lamp turning off is not related to the glow plug generating heat. If the ignition key is left in the "GLOW" position after the lamp is turned off, the plug will still generate heat. The thermo-start lamp will stay illuminated for five seconds.

9. Switch the ignition key to the "GLOW" position.

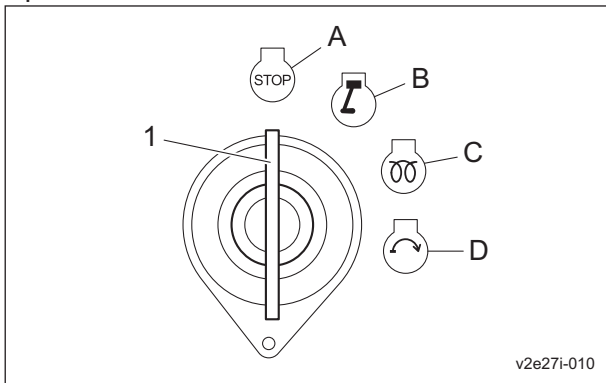

Procedure to Start Engine_002

1	Ignition key
A	OFF
B	ON
C	GLOW
D	START

10. Make sure that the glow plug is generating heat and the thermo-start lamp is turned on.

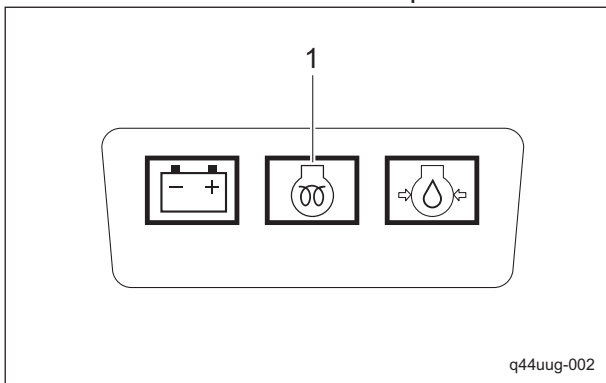

Procedure to Start Engine_003

1	Thermo-start lamp
---	-------------------

11. After the thermo-start lamp turns off, immediately set the ignition key to the "START" position.

Important

Quickly returning the ignition key from the "START" position to the "ON" position may result in damage to the device.

12. When the starter starts rotating and the engine starts, slowly return the ignition key to the "ON" position.

13. Make sure that the charge lamp and oil pressure lamp turn off. If they do not turn off, stop the engine and inspect the machine.

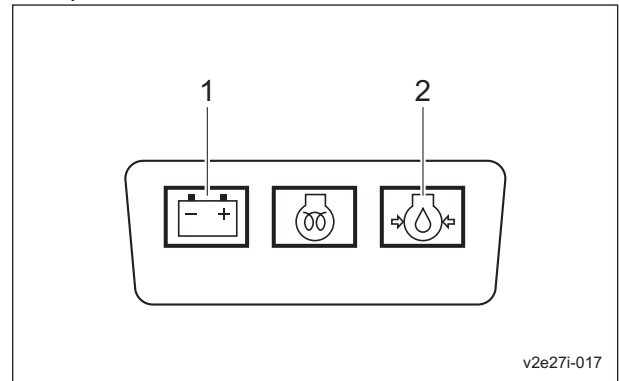

Procedure to Start Engine_004

1	Charge lamp
2	Oil pressure lamp

14. Move the throttle lever to the "Low speed" position, and then warm up the engine so that the needle points above "C" on the water temperature gauge.

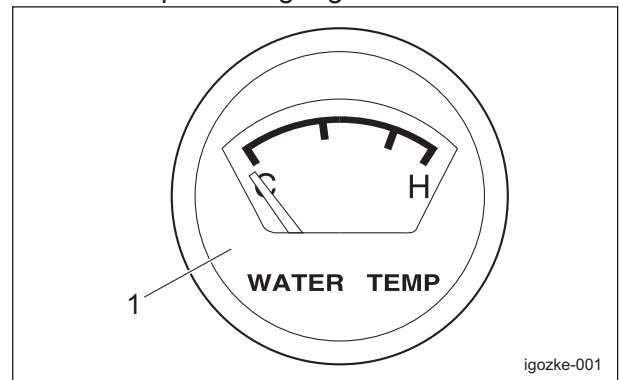

Procedure to Start Engine_005

1	Water temperature gauge
---	-------------------------

15. Gradually move the throttle lever to the "High speed" position.

Handling Instructions

Procedure to Stop Engine

1. Set the traveling pedal to the neutral position.
2. Apply the parking brake.
3. Set the reel rotation switch to the "Stop" position.
4. Shift the throttle lever to the "Low speed" position, and then warm up the engine for 1-2 minutes.
5. Lower all the mower units to the ground.
6. Switch the ignition key to the "OFF" position.
7. Make sure that the engine has stopped.

Parking and Stopping

Leaving the machine

Caution

If the brakes are not sufficiently effective, use the wheel stoppers to secure the machine.

Caution

Never park the machine on a slope.

1. Park the machine on level ground.
2. Apply the parking brake.
3. Stop the engine.
4. Remove the ignition key.
5. Install the rubber cap to the key switch.
6. Leave the driver's seat.
7. Close the fuel cock of the fuel filter.
8. Close the fuel cock of the water separator.

Move

Traveling Procedure

Caution

Under any circumstances drive the machine at such a speed that you can stop it immediately for emergencies.

Caution

Since traveling on steep downward slopes, wet surfaces and wet grassy downward slopes in 3WD is dangerous, use 2WD. Otherwise, the rear tires may slip and travel control may be lost.

Important

Do NOT start to move or stop the machine abruptly. It will damage the hydraulic system or result in oil leakage.

1. Start the engine.
"Procedure to Start Engine" (Page 5-17)
2. Raise all mower units.
3. Depress the brake pedal to release the parking brake.
4. Release the brake pedal.
5. Slowly depress the traveling pedal.
6. The machine starts traveling.
7. The machine stops with the traveling pedal released and the brake pedal depressed.

Handling Instructions

Cutting Work

Cutting Work

Warning

Do NOT start to move or stop the machine abruptly.

Caution

Cutting work must be performed at an appropriate speed for the site and location. When cutting over bumpy surfaces, keep the engine rpm steady, and slow down the cutting speed.

Caution

Reel rotation will be turned on or off based on the sensor-detected position of the mower units. Please note that if you stop operating the mower unit up/down lever before the mower units are raised completely, reel rotation may not stop.

Important

Mow with the lever shifted to the "DOWN" position. When the lever is returned to the neutral position, the cylinders are fixed, preventing mowing on undulations.

Important

Do NOT start to move or stop the machine abruptly. It will damage the hydraulic system or result in oil leakage.

1. Shift the reel rotation/stop switching levers of all mower units to the "Rotation" position.
2. Start the engine.
"Procedure to Start Engine" (Page 5-17)
3. Depress the brake pedal to release the parking brake.
4. Shift the throttle lever to the "High speed" position to run the engine at the maximum speed.
5. Shift the mower unit up/down lever to the "DOWN" position to lower the mower units.

6. Set the reel rotation switch to the "Rotation" position to rotate the reel cutters (cutting cylinders) of all mower units.
7. Depress the traveling pedal to start cutting work.

Removal/Installation of Grass Catcher

Caution

Stop the engine before removing or installing the grass catcher.

1. Set the reel rotation switch to the "Stop" position.
2. Lower the mower units.
3. Apply the parking brake.
4. Stop the engine.
5. Remove or install the grass catcher.
Removal of grass catcher:
Lift up the grass catcher, and remove the mounting pins on the left and right of the grass catcher from the grass catcher mounting brackets.
Installation of grass catcher:
Install the mounting pins on the left and right sides of the grass catcher into the grass catcher mounting brackets.
Mower unit #1

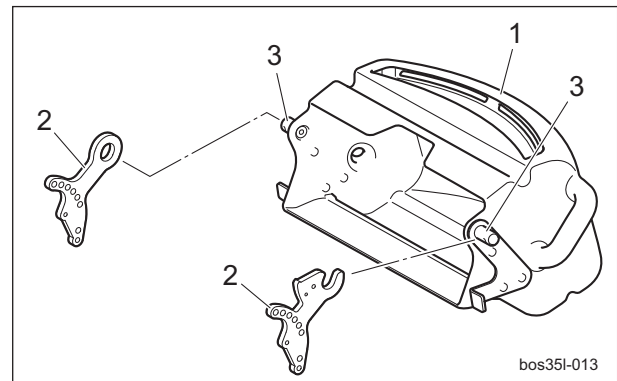

Removal/Installation of Grass Catcher_001

1	Grass catcher
2	Grass catcher mounting bracket
3	Mounting pin

Mower unit #2

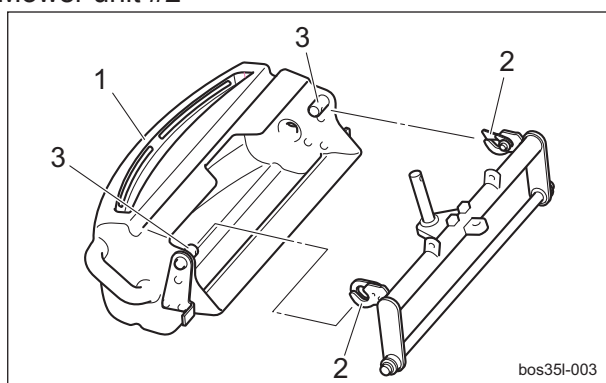

Removal/Installation of Grass Catcher_002

1	Grass catcher
2	Grass catcher mounting bracket
3	Mounting pin

Mower unit #3

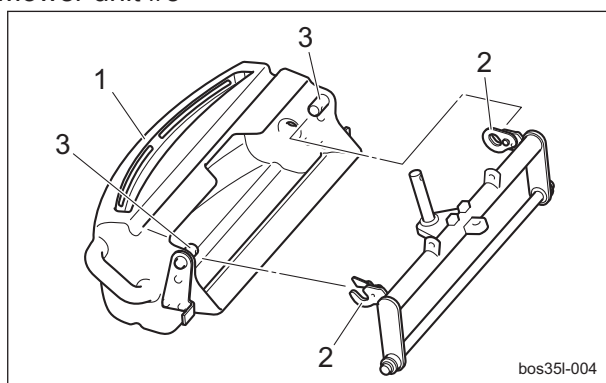

Removal/Installation of Grass Catcher_003

1	Grass catcher
2	Grass catcher mounting bracket
3	Mounting pin

Transporting

Transporting Procedure

When loading the machine into a trailer or a truck to transport it, drive the machine forward. When unloading, drive the machine in reverse.

Handling Instructions

Precautions for MaintenancePage 6-2**Jacking Up The Machine Page 6-2**

About Jacking Up The Machine Page 6-2

Jack-up Points Page 6-2

Lifting Points Page 6-3

Greasing Page 6-4

About Greasing Page 6-4

Greasing Points Page 6-4

Lubrication Page 6-7

About Lubrication Page 6-7

Lubricating Points Page 6-7

Adjustment and Replacement Page 6-8

Adjustment of Mower Stopper Pin Page 6-8

Adjustment of Mower Stabilizer (LH
Unit) Page 6-8

Replacement of Tires Page 6-9

Adjustment of Belt Tension Page 6-10

Change of Coolant Page 6-11

Change of Hydraulic Oil Page 6-12

Change of Hydraulic Oil Filter Page 6-14

Change of Air Cleaner Page 6-15

Change of Engine Oil Page 6-15

Change of Engine Oil Filter Page 6-16

Change of Fuel Filter Element Page 6-17

Storage Page 6-18

Long-Term Storage Page 6-18

Maintenance

Precautions for Maintenance

Warning

The chapter "Maintenance" in this manual describes practical measures which should be performed by a mechanic with expertise. The owner should instruct the mechanic with expertise to perform maintenance service for this machine.

Caution

First, learn well the operations you plan to perform.

Important

Use tools appropriate for each operation.

Important

Use Baronsess genuine parts for replacement and accessories. Our product warranty may be void if you use non-genuine parts for replacement or accessories.

Jacking Up The Machine

About Jacking Up The Machine

Warning

When replacing a tire or beginning any other maintenance or repairs, be sure to chock the wheels to prevent the machine from moving. Before jacking up the machine, park it on a hard, flat surface such as a concrete floor and remove any obstacles that could prevent you from performing the work safely. When necessary, use an appropriate chain block, hoist, or jack. Support the machine securely with jack stands or appropriate blocks. Failure to do so may cause the machine to move or fall, resulting in injury or death.

Important

Only place a jack under the jack-up points specified. Placing a jack at any other point will result in damage to the frame or other parts.

Use the jack-up points identified in this manual when jacking up the machine.

Jack-up Points

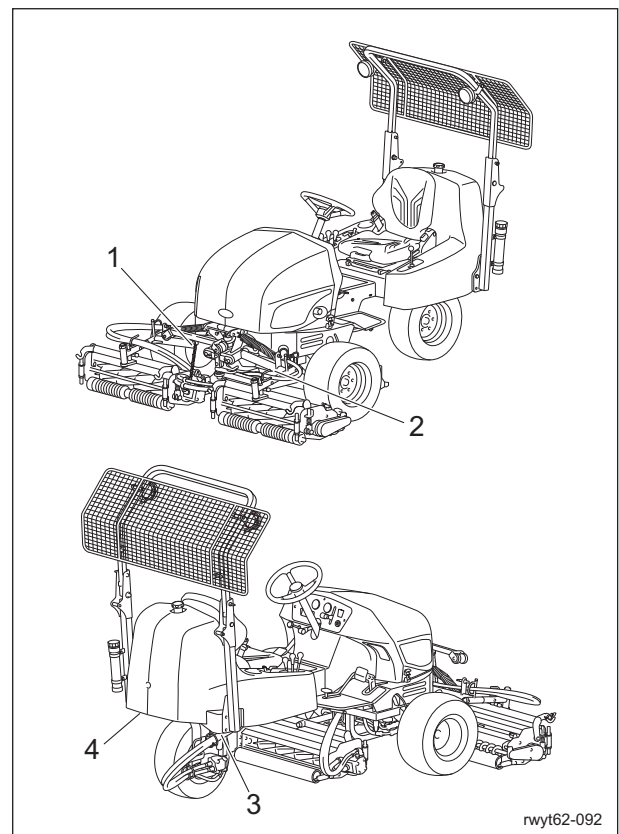

Jack-up Points_001

	Jack-up Points
1	Front right frame
2	Front left frame
3	Rear right frame
4	Rear left frame

1. Front right frame

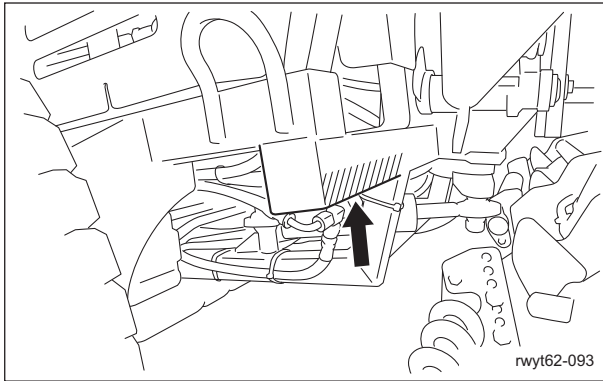

Jack-up Points_002

2. Front left frame

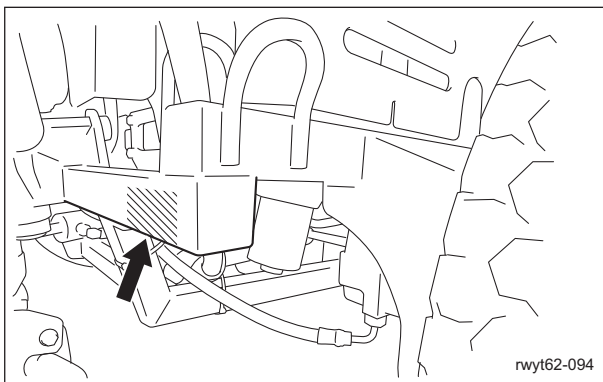

Jack-up Points_003

3. Rear right frame

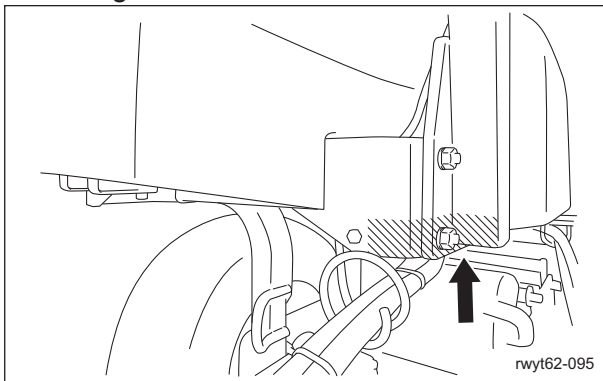

Jack-up Points_004

4. Rear left frame

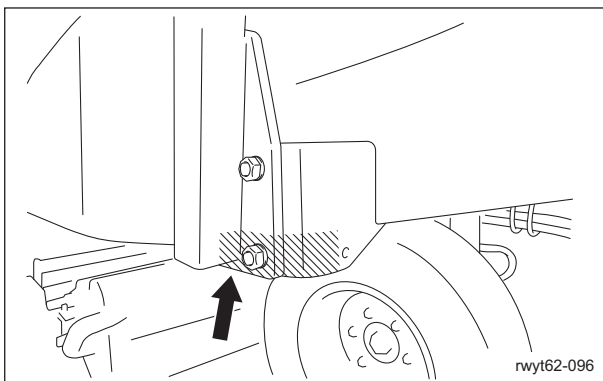

Jack-up Points_005

Lifting Points

Important

Be sure to use adequately strong cables.

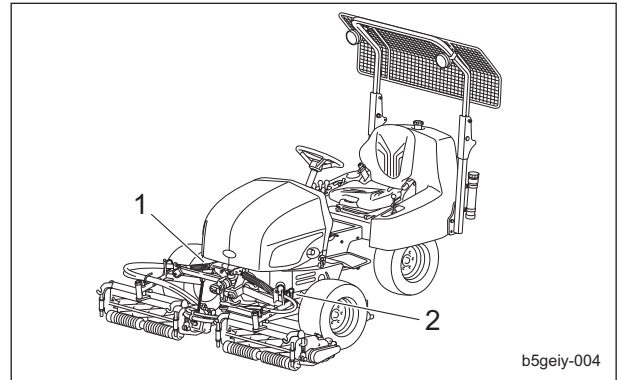

Lifting Points_001

	Lifting points
1	Front right frame
2	Front left frame

1. Front right frame

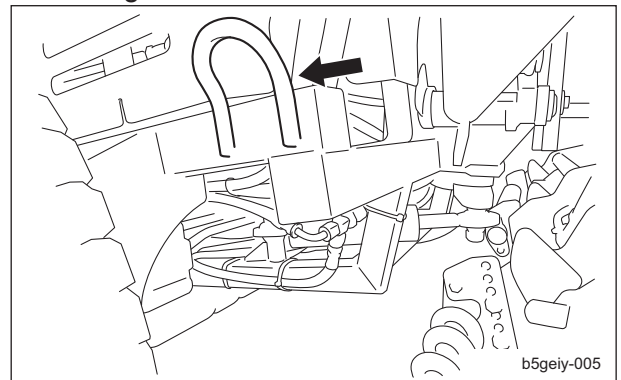

Lifting Points_002

2. Front left frame

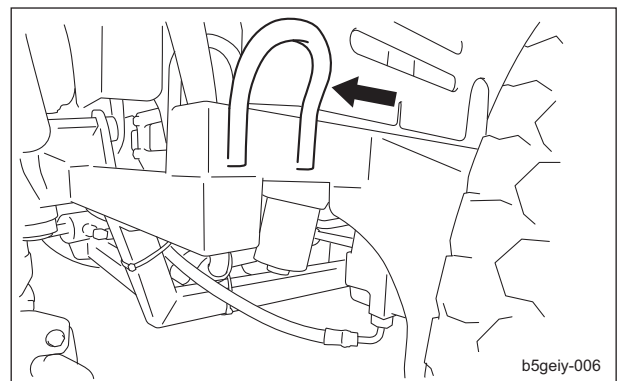

Lifting Points_003

Maintenance

Greasing

About Greasing

Since there may be adhesion or damage due to lack of grease on moving parts, they must be greased.

Add urea-based No. 2 grease in accordance with the Maintenance Schedule.

Other locations where the specified grease or lubricant is used are indicated in "Greasing Points".

Add grease using the specified grease or lubricant.

Greasing Points

Grease nipples are installed in the following locations.

Add grease every 50 hours of operation.

If specified locations, periods and grease are additionally described below, follow the instructions.

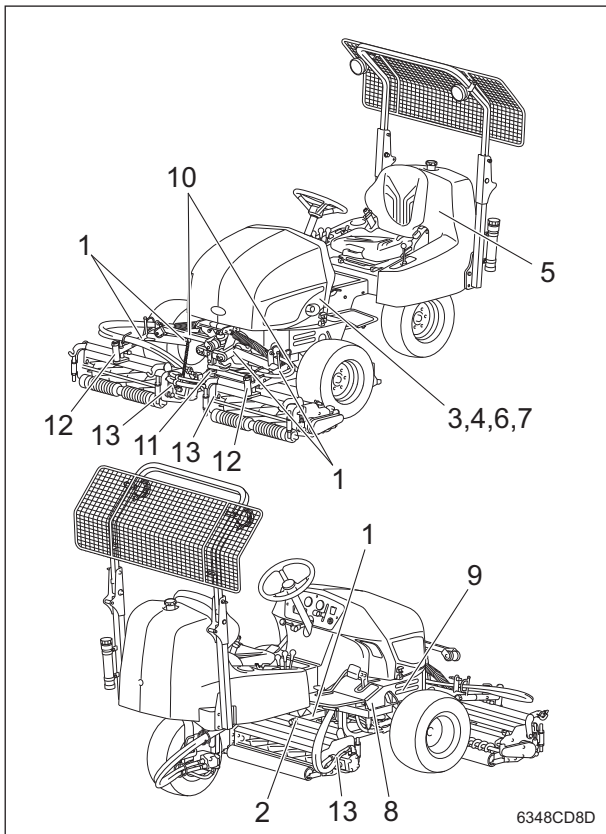

Greasing Points_001

	Location	No. of greasing points
1	Lift arm fulcrum	5
2	Mower arm fulcrum	1
3	Brake pedal shaft fulcrum	1
4	Brake lever shaft	1
5	Rear wheel housing	1
6	Tension lever	1
7	Neutral cam lever	1
8	Traveling pedal shaft fulcrum	1
9	Traveling pedal relay lever	1
10	Front wheel brake lever	2
11	Mower lift cam lever	1
12	Mower coupling	2
13	Reel motor shaft	3

1. Lift arm fulcrum

Mower unit #1

There is one greasing point on the lift arm fulcrum connected to the mower unit.

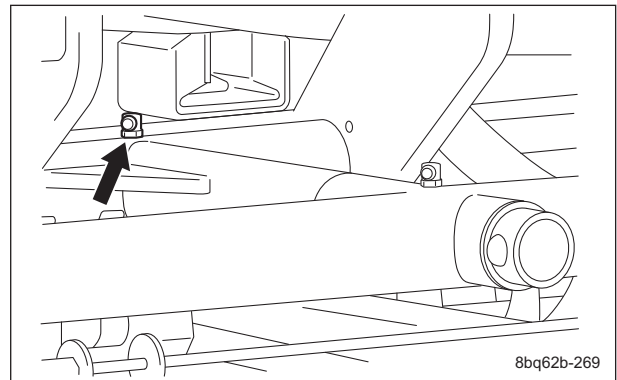

Greasing Points_002

Mower units #2 and #3

There are two greasing points on the lift arm fulcrum connected to each mower unit.

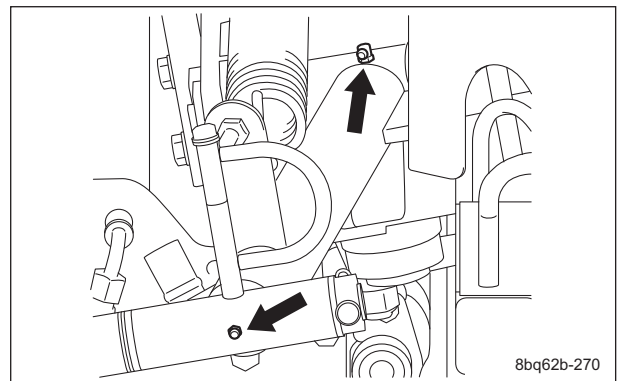

Greasing Points_003

2. Mower arm fulcrum

Mower unit #1

There is one greasing point on the mower arm fulcrum.

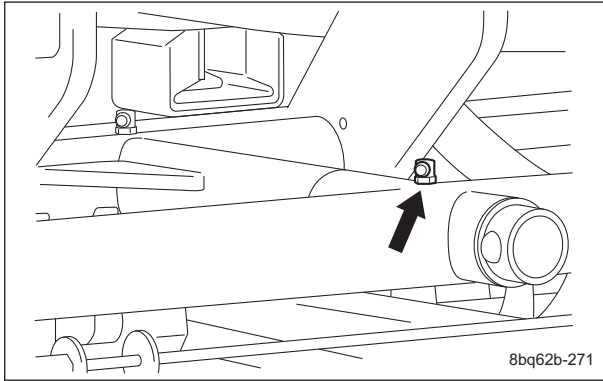

Greasing Points_004

3. Brake pedal shaft fulcrum

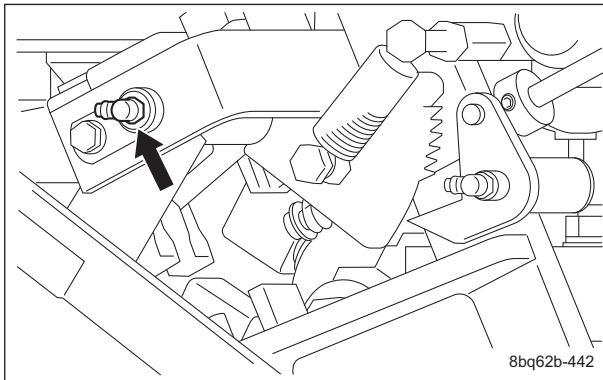

Greasing Points_005

4. Brake lever shaft

Add grease every 100 hours of operation or every year, whichever comes earlier.

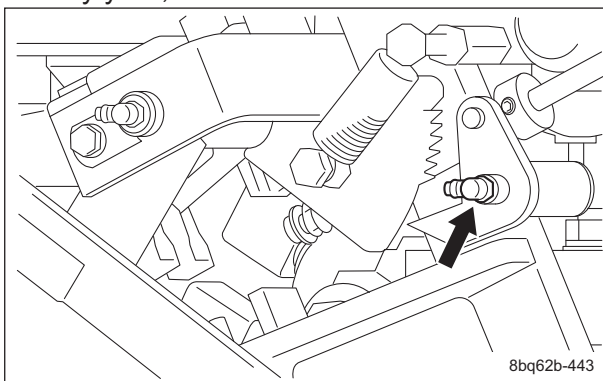

Greasing Points_006

5. Rear wheel housing

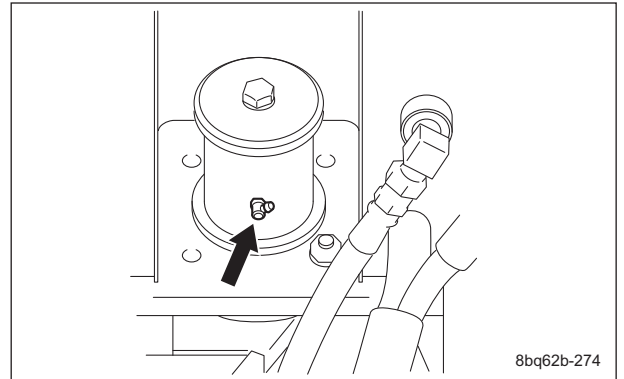

Greasing Points_007

6. Tension lever

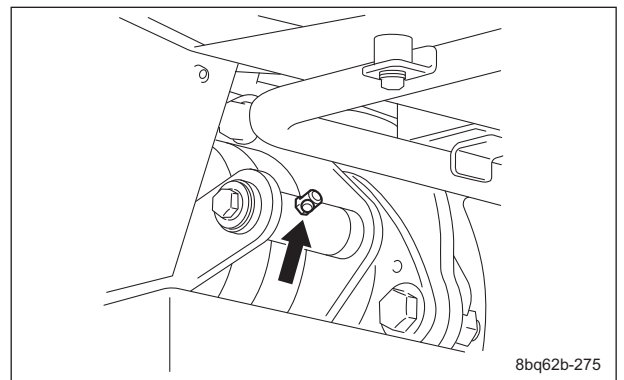

Greasing Points_008

7. Neutral cam lever

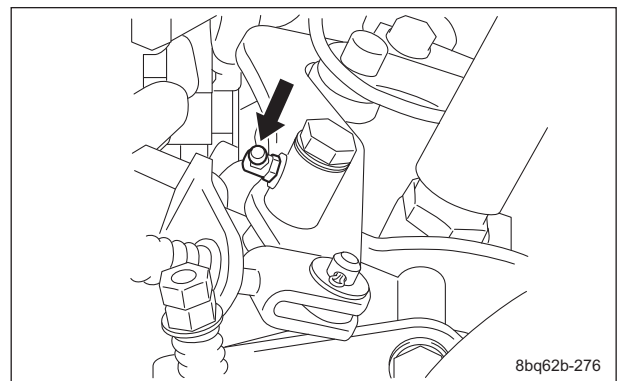

Greasing Points_009

8. Traveling pedal shaft fulcrum

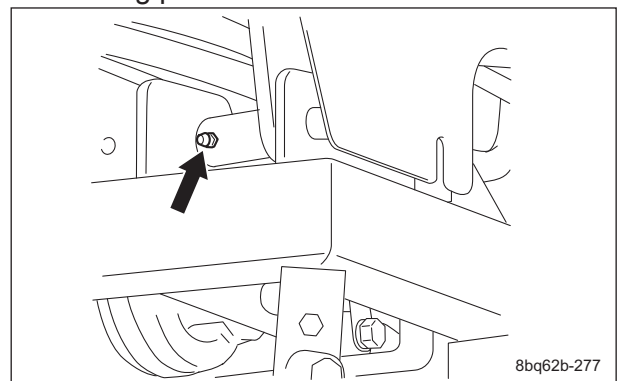

Greasing Points_010

Maintenance

9. Traveling pedal relay lever

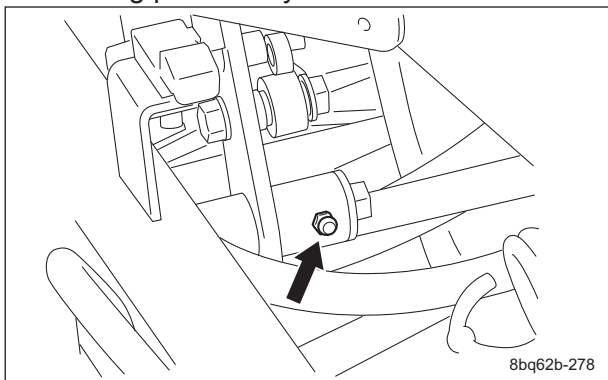

Greasing Points_011

11. Mower lift cam lever

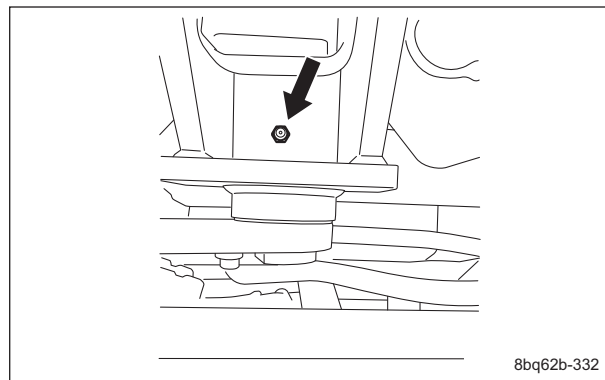

Greasing Points_014

10. Front wheel brake lever

There is one greasing point each on the left and right sides.

Left side

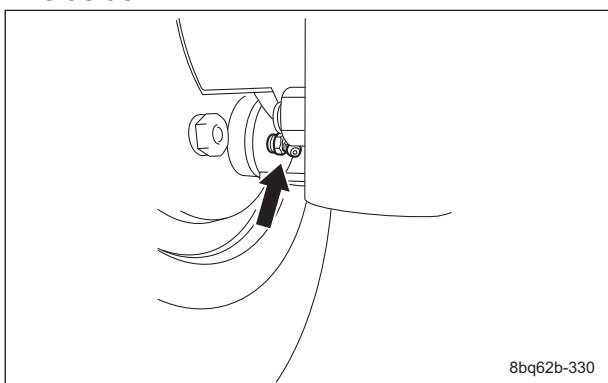

Greasing Points_012

Right side

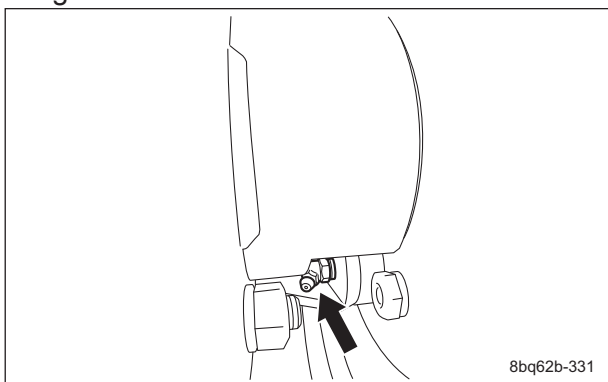

Greasing Points_013

12. Mower coupling

Mower unit #2 and #3

There is one greasing point each on the couplings connecting the mower units.

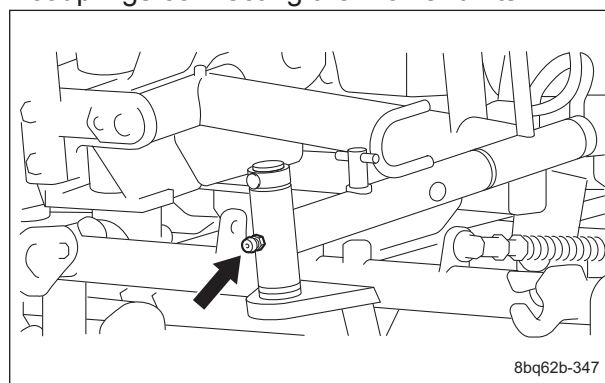

Greasing Points_015

13. Reel motor shaft

Apply 2 g (0.004 lb) of MORI SPEED GREASE NO.2 to the reel motor shaft mounted on each mower unit every 250 hours.

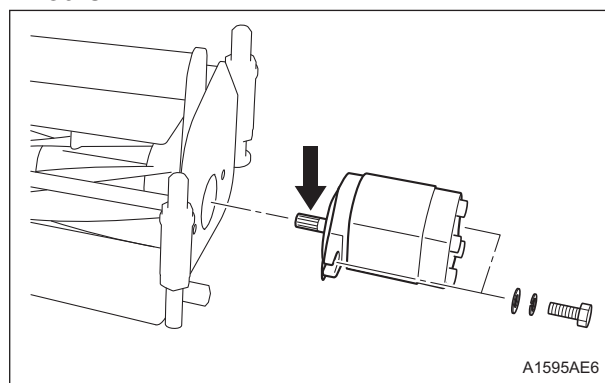

Greasing Points_016

Lubrication

About Lubrication

It is necessary to lubricate moving parts so that they will not become stuck or damaged. The locations where lubricant is used are indicated in "Lubricating Points". Apply the lubricant.

Lubricating Points

Apply lubricant at the following locations every 50 hours of operation.

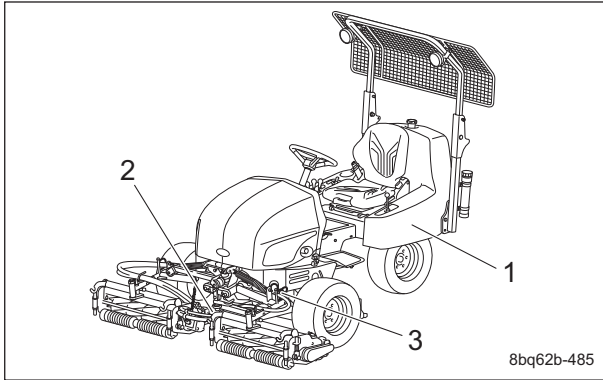

Lubricating Points_001

	Location	No. of greasing points
1	Steering cylinder spherical bearing	2
2	Front mower cylinder spherical bearing	2
3	Rear mower cylinder spherical bearing	1

1. Steering cylinder spherical bearing
There are two locations.

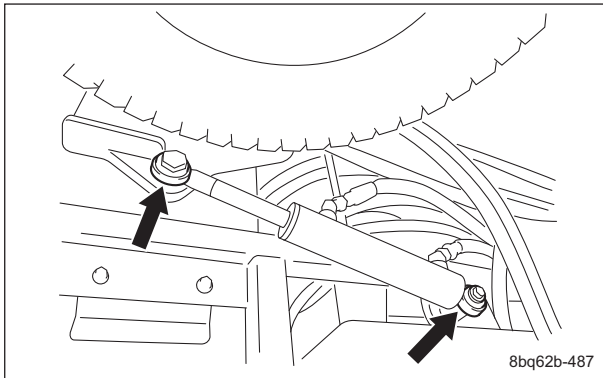

Lubricating Points_002

2. Front mower cylinder spherical bearing
There are two locations.

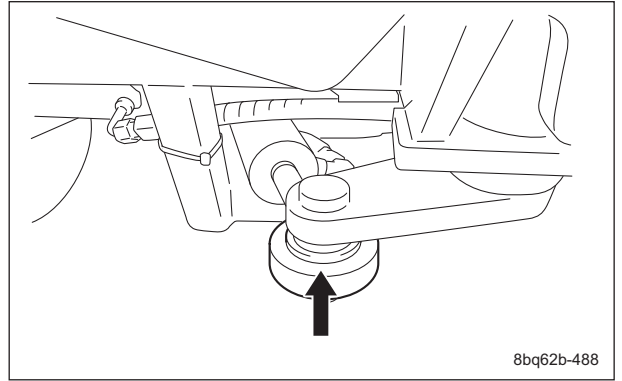

Lubricating Points_003

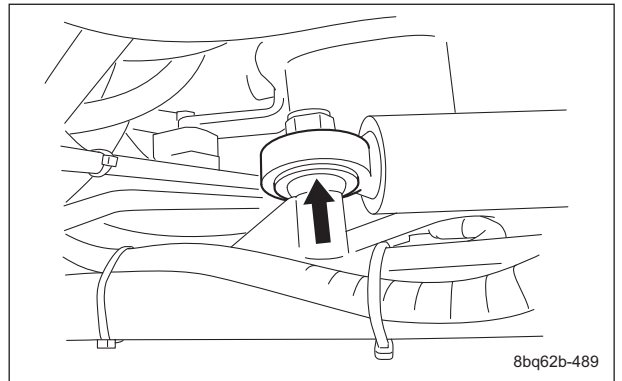

Lubricating Points_004

3. Rear mower cylinder spherical bearing
There is one location.

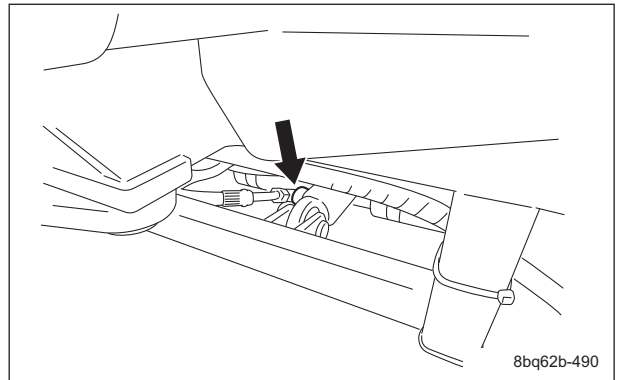

Lubricating Points_005

Maintenance

Adjustment and Replacement

Adjustment of Mower Stopper Pin

Note:

Depending on the specifications, this function may not be available.

The mower stopper pin can prevent or allow tilting of the mower units.

Adjust according to the operating conditions.

Fixed:

- The mowing line while traveling straight ahead is a straight line. (The mowing line is easy to see.)
- The mower units do not tilt while operating on slopes, and incomplete mowing can be reduced.

Released:

- It is appropriate when turning while mowing or it is easy to follow undulations.
1. With the machine on a level surface, lower all mower units.
 2. Apply the parking brake, and then stop the engine.
 3. Adjust the position of the mower stopper pin, and then insert the cotter pin.

To fix:

Insert the cotter pin into the upper hole in the mower stopper pin.

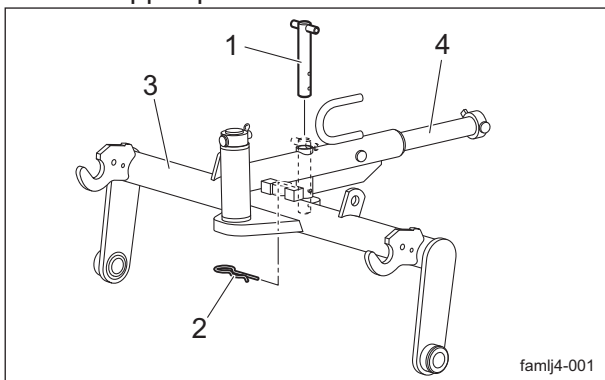

Adjustment of Mower Stopper Pin_001

1	Mower stopper pin
2	Cotter pin
3	Mower arm
4	Mower coupling

To release:

Insert the cotter pin into the lower hole in the mower stopper pin.

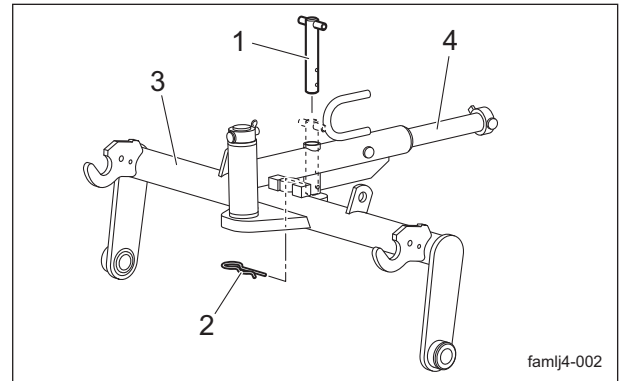

Adjustment of Mower Stopper Pin_002

1	Mower stopper pin
2	Cotter pin
3	Mower arm
4	Mower coupling

Adjustment of Mower Stabilizer (LH Unit)

Note:

Depending on the specifications, this function may not be available.

Important

After adjusting the cutting height, adjust the mower stabilizer.

The mower stabilizer stabilizes the mower units and prevents an undulating finish (a phenomenon called Marcelling).

1. Lower all mower units on a level place.
2. Apply the parking brake, and then stop the engine.
3. Loosen the lock nut.
4. Tighten the nut to adjust the length of the spring (compression).
 - Mower #2 and #3: 140.0 mm (5.51 in)
 - Mower #1: 60.0 mm (2.36 in)
5. Tighten the lock nut.

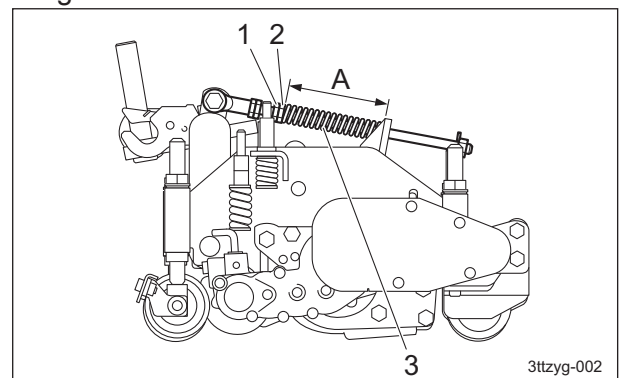

Adjustment of Mower Stabilizer (LH Unit)_001

1	Lock nut
2	Nut
3	Spring
A	Mower #2 and #3: 140.0 mm (5.51 in) Mower #1: 60.0 mm (2.36 in)

Replacement of Tires

Replacement of Front Tires

1. Removing front tires

Follow the steps below to remove the front tires:

[1] Loosen the bolts.

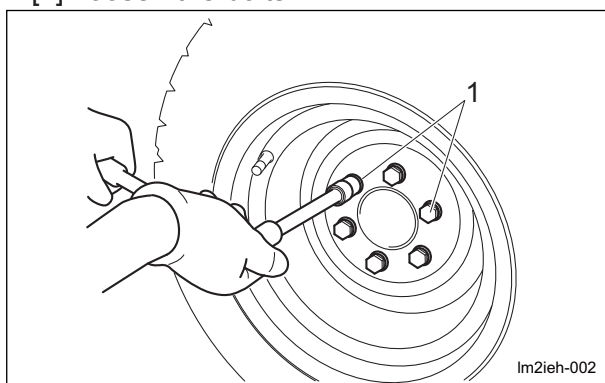

Replacement of Front Tires_001

1	Heat-treated bolt
---	-------------------

[2] Securely place the jack beneath the jack-up point of the front left/right frame area, and then raise it until the tire lifts off the ground.

"Jack-up Points" (Page 6-2)

[3] Remove the bolts.

[4] Remove the tire from the wheel mounting seat.

2. Installing front tires

Important

Tighten the bolts in the tightening order (diagonally).

Important

Tighten the wheel mounting bolts on the specified torque by using a torque wrench.

For installing the front tires, reverse the removing procedure.

Replacement of Rear Tires

1. Removing rear tires

Follow the steps below to remove the rear tires

[1] Loosen the bolts.

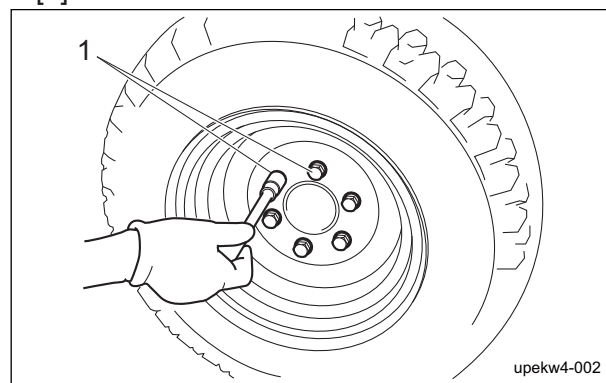

Replacement of Rear Tires_001

1	Heat-treated bolt
---	-------------------

[2] Securely place the jack beneath the jack-up point of the rear frame area, and then raise it until the tire lifts off the ground.

"Jack-up Points" (Page 6-2)

[3] Remove the bolts.

[4] Remove the tire from the wheel mounting base.

2. Installing rear tires

Important

Tighten the bolts in the tightening order (diagonally).

Important

Tighten the wheel mounting bolts on the specified torque by using a torque wrench.

For installing the rear tires, reverse the removing procedure.

Maintenance

Adjustment of Belt Tension

Warning

Be sure to stop the engine before adjusting the belts.

Important

Before making sure of belt tension, rotate the belt several times.

If the belt becomes slack due to frequent use, it may jump or slip.

In addition, if it is overtightened, it may wear prematurely.

If necessary, adjust it, and always check the belt for appropriate tension.

Fan Belt

1. Press the middle of the belt with your finger to check the belt tension.

The belt tension is appropriate when the belt slacks by approximately 10.0 mm (0.39 in) when you apply a force of 98 N (10 kgf) to the belt at the middle point between the pulleys.

2. If the belt tension is incorrect, loosen bolt A and bolt B (securing the alternator), and then move the alternator to adjust the tension.

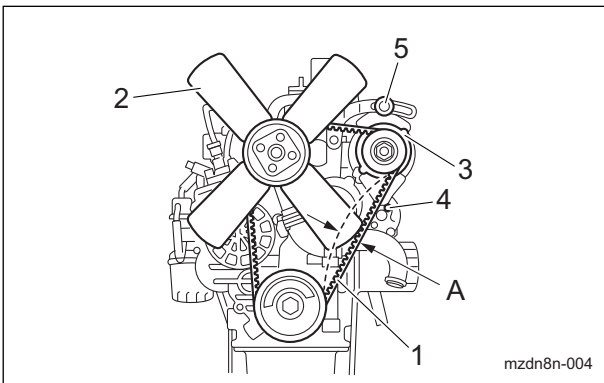

Fan Belt_001

1	Fan Belt
2	Blade
3	Alternator
4	Bolt A
5	Bolt B
A	10 mm (0.39 in)

Hydraulic Pump Drive Belt

1. Open the hood.

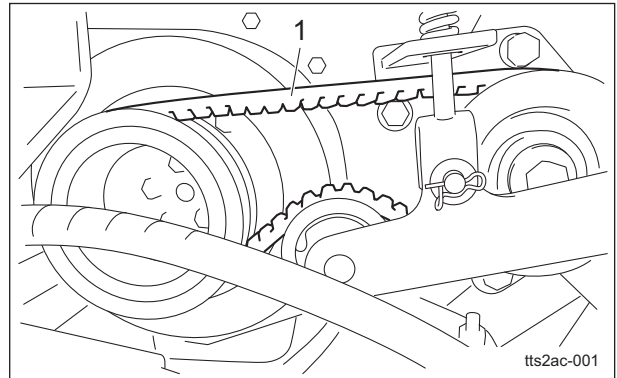

Hydraulic Pump Drive Belt_001

1	Hydraulic pump drive belt
---	---------------------------

2. Loosen the lock nut, and then turn the nut to adjust the length of the spring to 35.0 mm (1.38 in).
3. Secure with the lock nut.

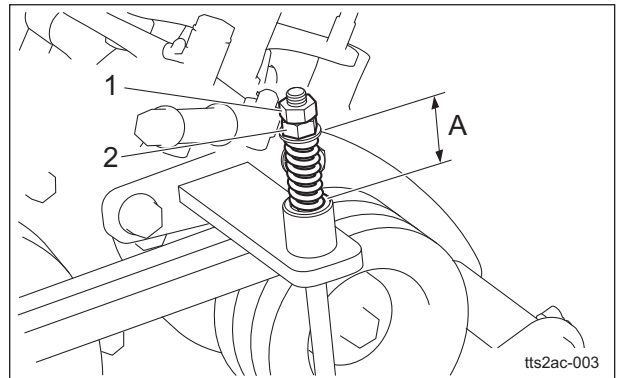

Hydraulic Pump Drive Belt_002

1	Lock nut
2	Nut
A	30.0 - 35.0 mm (1.18 - 1.38 in)

Change of Coolant

⚠ Caution

Do not touch the radiator or coolant during engine operation or immediately after the engine has been turned off. Otherwise, you may get burned due to high temperatures.

⚠ Caution

Change coolant after the engine has well cooled down.

⚠ Caution

The radiator cap is pressurized. If you remove the radiator cap while the engine is overheated, hot steam will burst out, possibly resulting in burns. Make sure that the water temperature and pressure are reduced, and then grab the cap with a thick cloth and gradually open the cap.

Important

When changing the coolant, be sure to drain it into a container and discard it in accordance with local laws and regulations.

Important

When changing the coolant, be sure to mix clean water and antifreeze (long-life coolant), and then pour it into the radiator and reserve tank.

Important

Tightly close the radiator cap. If the cap is loose or incorrectly installed, the engine will be overheated due to water leakage, resulting in engine damage.

When mixing antifreeze and clean water, refer to "Relationship between concentration of long-life coolant (LLC) and freezing temperature" below for the mixing ratio.

Relationship between concentration of long-life coolant (LLC) and freezing temperature

Freezing temperature	LLC concentration (volume %)
Down to -10 °C (14 °F)	20 %
Down to -15 °C (5 °F)	30 %
Down to -20 °C (-4 °F)	35 %
Down to -25 °C (-13 °F)	40 %

1. Stop the engine, and then allow the radiator to cool.
2. Open the hood.
3. Follow the steps below to drain the coolant.
 - [1] Position a container to drain the coolant into.
 - [2] Remove the drain plug from the radiator.

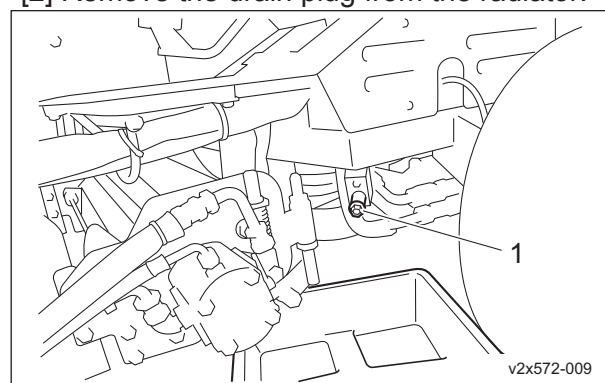

Change of Coolant_001

1	Radiator drain plug
---	---------------------

- [3] Remove the radiator cap.

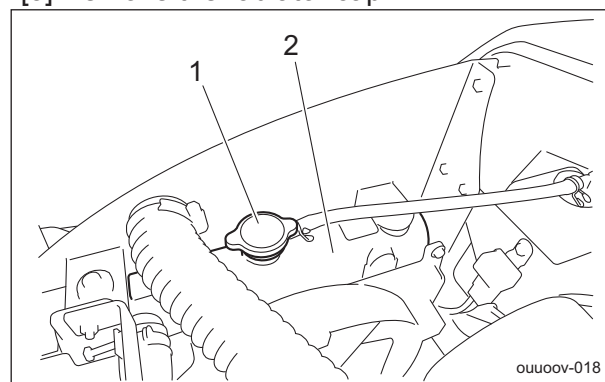

Change of Coolant_002

1	Radiator cap
2	Radiator

Maintenance

[4] Remove the reserve tank.

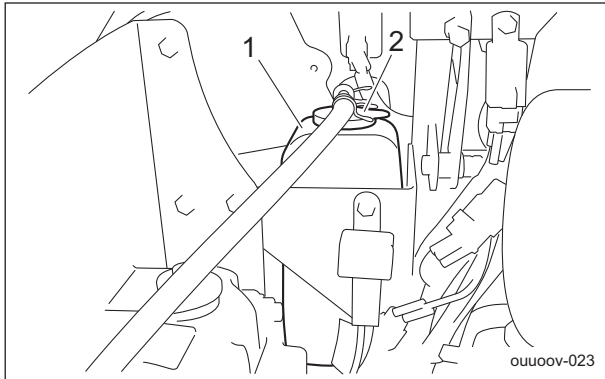

Change of Coolant_003

1	Reserve tank
2	Reserve tank cap

[5] Open the reserve tank cap, and then drain the coolant.

4. Install the reserve tank.
5. Clean the radiator with clean water to remove any debris or rust.
6. Drain all water from the radiator.
7. Follow the steps below to fill with coolant. The coolant quantity, including the reserve tank, is 3.1 dm³ (3.1 L).
 - [1] Install the drain plug.
 - [2] Supply clean water and antifreeze into the radiator up to the radiator cap opening.
 - [3] Close the radiator cap.
 - [4] Supply clean water and antifreeze into the reserve tank up to the "FULL" mark.
 - [5] Close the reserve tank cap.
8. Start the engine, and then idle for several minutes to bleed air from the system.
9. Stop the engine, and then allow the radiator to cool.
10. Check if the coolant level in the reserve tank is between "FULL" and "LOW", and then supply coolant if necessary.
11. Close the hood.

Change of Hydraulic Oil

⚠ Caution

Be careful with hot oil, which could cause burns if it contacts your skin.

Important

When you change the hydraulic oil, be sure to drain it into a bowl and discard it in accordance with local laws and regulations.

Important

If the hydraulic oil emulsifies or if it becomes even slightly less transparent, change the oil immediately.

Important

Use Shell Tellus S2M46 (or equivalent) as hydraulic oil.

In case of an equivalent, consult Characteristics of Hydraulic Oil and use hydraulic oil whose characteristics are superior to those of the specific hydraulic oil. Especially regarding kinematic viscosity and viscosity index, use of hydraulic oil whose figures are less than those of the specified hydraulic oil will cause a malfunction in the hydraulic circuit.

Note:

Characteristics of Hydraulic Oil

Specified Hydraulic Oil		Shell Tellus S2M46
ISO Viscosity Grade		ISO VG46
Density	15 °C (59 °F)	0.873 g/cm ³ (0.0315 lb/in ³)
API Gravity		30.6
Flash Point (Open Cup)		230 °C (446 °F)
Pour Point		-30 °C (-22 °F)
Kinematic Viscosity	40 °C (104 °F)	46 mm ² /s (46 cSt)
	100 °C (212 °F)	7 mm ² /s (7 cSt)
Viscosity Index		109

1. Follow the steps below to remove the old oil.
 - [1] Start and run the engine to warm up the oil.
 - [2] On a level surface, lower the mower units, and then stop the engine.
 - [3] Remove the drain plug of the hydraulic tank and drain the old oil into a bowl.

- [4] Wind new sealing tape on the drain plug, and then install the drain plug into the hydraulic tank.

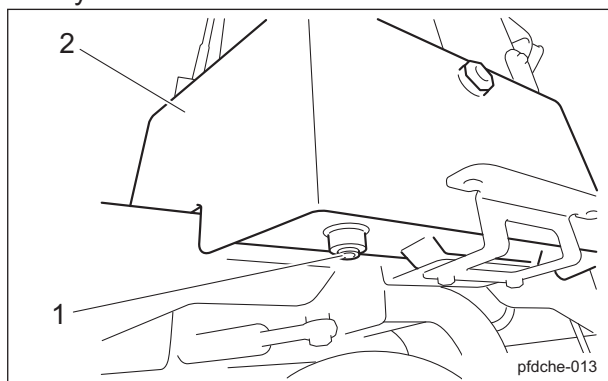

Change of Hydraulic Oil_001

1	Drain plug
2	Hydraulic tank

- Remove the rear cover.
"Removing and Installing of Rear Cover"
(Page 5-2)
- Follow the steps below to supply new hydraulic oil.
The hydraulic tank capacity is approximately 26.0 dm³ (26.0 L).
■ #10001-10278

- [1] Open the tank cap.
- [2] Supply hydraulic oil through the oil filling port until the oil level reaches the middle of the oil gauge on the hydraulic tank.
- [3] Tighten the tank cap securely.

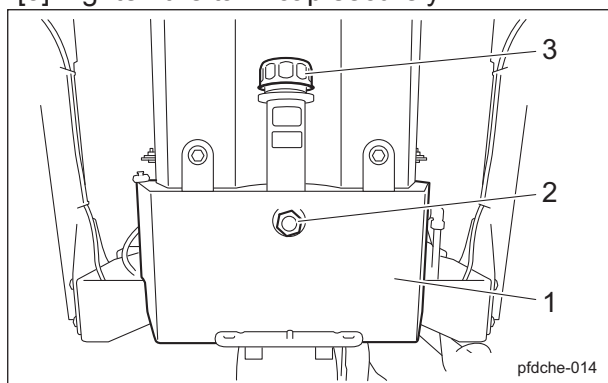

Change of Hydraulic Oil_002

1	Hydraulic tank
2	Oil gauge
3	Tank cap

■ #10279-

- [1] Loosen the bushing with a wrench and remove the oil filler plug.

- [2] Supply hydraulic oil through the oil filling port until the oil level reaches the middle of the oil gauge on the hydraulic tank.
- [3] Install the oil filler plug and tighten the bushing securely.

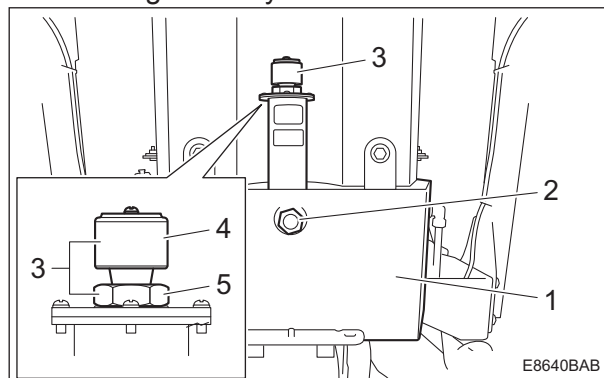

Change of Hydraulic Oil_003

1	Hydraulic tank
2	Oil gauge
3	Oil filler plug
4	Air breather
5	Bushing

- Start the engine, raise and lower the mower units, and turn the steering wheel left and right.
Move forward and reverse repeatedly several times.
- Raise the mower units and maintain that position on a level surface, and then check to see if the oil level is at the middle of the oil gauge. If necessary, supply oil.
- Check underneath the machine for hydraulic oil leakage.
- Install the rear cover.

Maintenance

Change of Hydraulic Oil Filter

Caution

Be careful with hot oil, which could cause burns if it contacts your skin.

Important

When replacing the hydraulic oil filter, be sure to drain the oil into a container and discard it in accordance with local laws and regulations.

Important

If the hydraulic oil emulsifies or if it becomes even slightly less transparent, change the oil immediately.

Important

Use Shell Tellus S2M46 (or equivalent) as hydraulic oil.

1. On a level surface, lower the mower units, and then stop the engine.
2. Loosen the filter case and remove it.

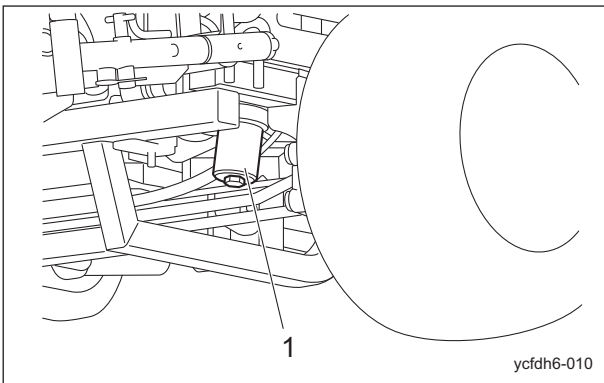

Change of Hydraulic Oil Filter_001

1	Filter case
---	-------------

3. Remove the old filter cartridge.

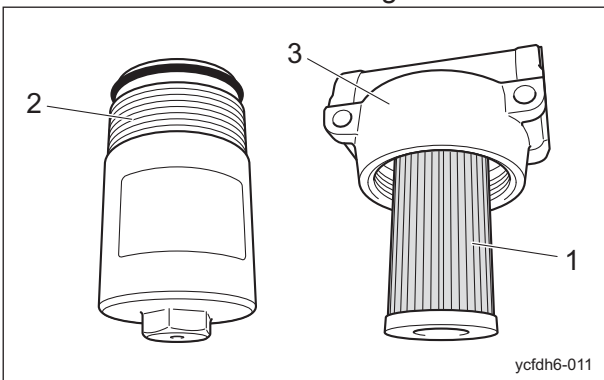

Change of Hydraulic Oil Filter_002

1	Filter cartridge
2	Filter case
3	Body

4. Lightly coat the O-ring of the new filter cartridge with hydraulic oil, and then install the cartridge.

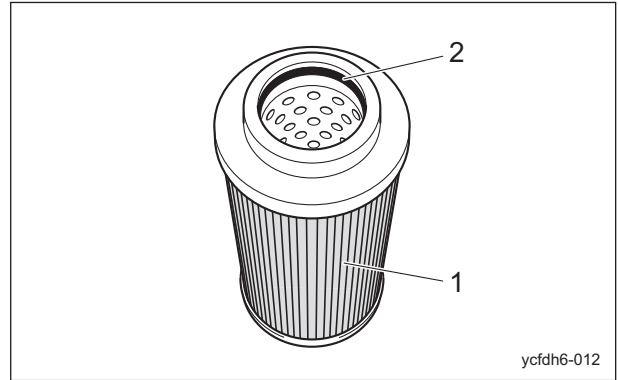

Change of Hydraulic Oil Filter_003

1	Filter cartridge
2	O-ring

5. Clean the inside of the filter case.
6. Make sure that there is no damage to the O-ring of the filter case, and then lightly coat the O-ring with hydraulic oil.

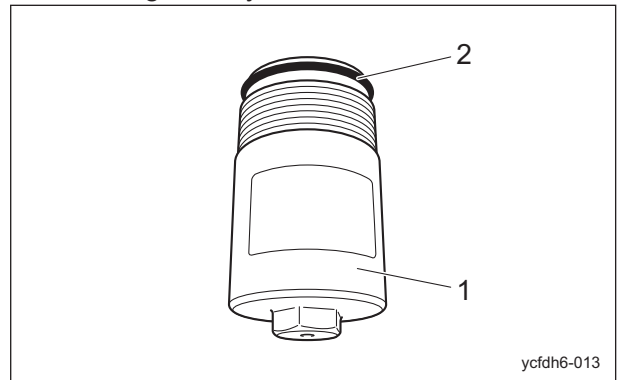

Change of Hydraulic Oil Filter_004

1	Filter case
2	O-ring

7. Install the filter case onto the body, firmly hand-tighten it, and then tighten it to 25 to 35 N·m (254.93 - 356.90 kgf).

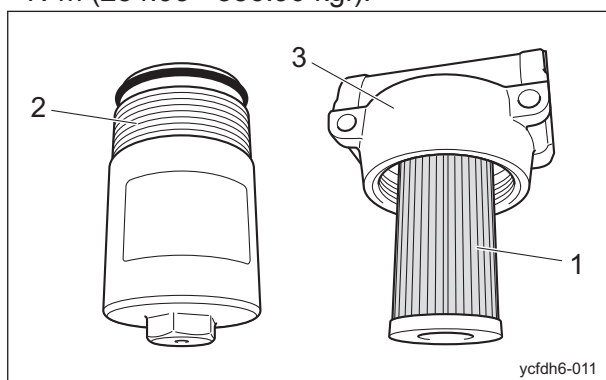

Change of Hydraulic Oil Filter_005

1	Filter cartridge
2	Filter case
3	Body

8. Supply hydraulic oil until it reaches the specified level.
"Hydraulic Oil Supply" (Page 5-7)

Change of Air Cleaner

A contaminated air cleaner element may cause malfunction of the engine.

To maximize the life of the engine, replace the air cleaner element at the appropriate times.

1. The timing for replacing the air cleaner element is described below.

[1] Replace the air cleaner element in accordance with the Maintenance Schedule.

[2] If it is significantly contaminated, replace it, even if the hours of operation do not exceed the specified time.

2. Replace the air cleaner element by following the same steps as for cleaning the air cleaner.

"Cleaning of Air Cleaner" (Page 5-9)

Change of Engine Oil

⚠ Caution

Be careful with hot oil, which could cause burns if it contacts your skin.

Important

When changing the engine oil, be sure to drain it into a container and discard it in accordance with local laws and regulations.

Important

Be sure to use engine oil that is classified as API Service Grade CF or higher, with an SAE Viscosity that is appropriate for the operating environment (ambient temperature).

Important

Securely tighten the oil level gauge and oil filler cap.

Change the engine oil more frequently if it is contaminated and especially if you use the machine in dusty areas or operate the engine at high loads or in high temperatures.

1. Follow the steps below to remove the old engine oil.

[1] Start and run the engine to warm up the engine oil.

[2] With the machine on a level surface, stop the engine.

[3] Remove the drain plug, and then drain the old engine oil into a container.

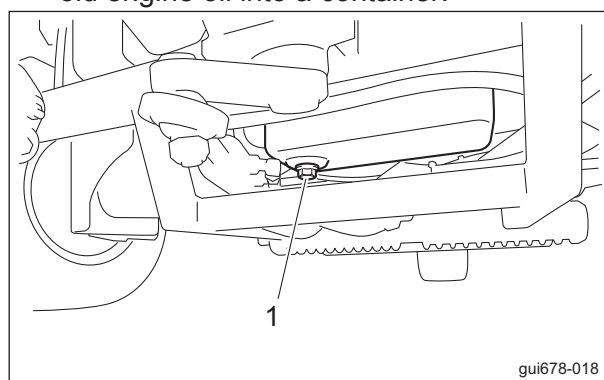

Change of Engine Oil_001

1	Drain plug
---	------------

[4] Re-place the drain plug.

2. Remove the oil filler cap, and then supply new engine oil until the oil reaches a level in between the upper and lower limit lines on the oil level gauge.

Engine oil quantity is approximately 3.7 dm³ (3.7 L).

Maintenance

3. Securely install the oil filler cap.

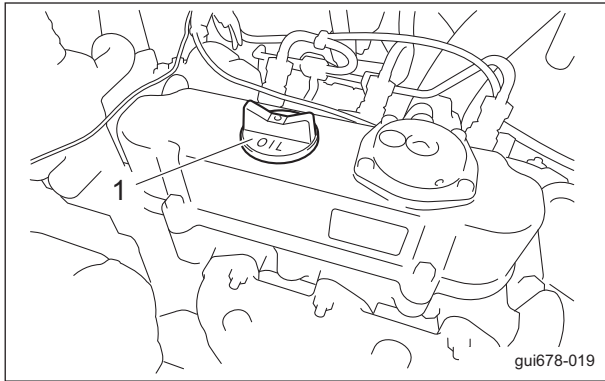

Change of Engine Oil_002

1	Oil filler cap
---	----------------

4. It will take a while for the supplied engine oil to descend into the oil pan.
Check the oil level again 10 to 20 minutes after supplying the oil.
5. Check underneath the machine for oil leakage.

Change of Engine Oil Filter

⚠ Caution

Be careful with hot oil, which could cause burns if it contacts your skin.

Important

When replacing the engine oil filter, be sure to drain the engine oil into a container and discard it in accordance with local laws and regulations.

Important

Be sure to use engine oil that is classified as API Service Grade CF or higher, with an SAE Viscosity that is appropriate for the operating environment (ambient temperature).

Important

Securely tighten the oil level gauge and oil filler cap.

1. With the filter wrench, remove the old filter cartridge.

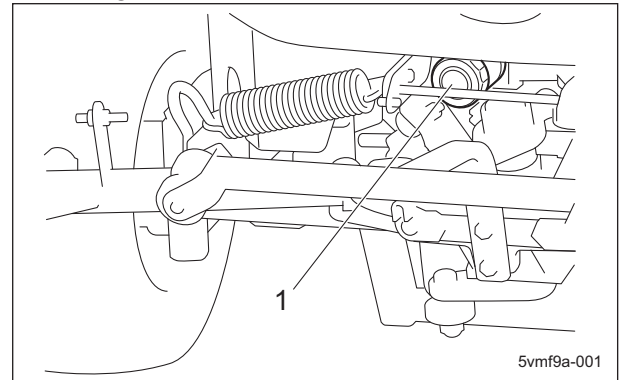

Change of Engine Oil Filter_001

1	Filter cartridge
---	------------------

2. Lightly coat the packing of the new filter cartridge with engine oil.
3. Hand-tighten the filter cartridge until the packing contacts the sealing surface, and then firmly hand-tighten (without using a filter wrench).
4. Supply engine oil until it reaches the specified level.
"Supply of Engine Oil" (Page 5-12)
5. Start the engine, and then stop it after 10 to 20 minutes.
6. Make sure that there is no oil leakage at the sealing surface of the filter cartridge.
7. Check the engine oil level.
If it is low, supply engine oil until it reaches the specified level.

Change of Fuel Filter Element

If dust or dirt accumulates in the fuel filter, the fuel flow will become insufficient.

Replace the fuel filter at the appropriate times. The fuel filter is on the left side under the rear right of the seat.

1. Close the fuel cock of the fuel filter.

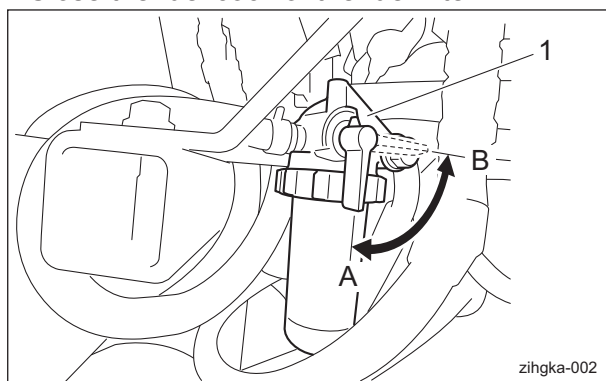

Change of Fuel Filter Element_001

1	Fuel filter
A	ON (open)
B	OFF (close)

2. Remove the ring nut, and then remove the cup.

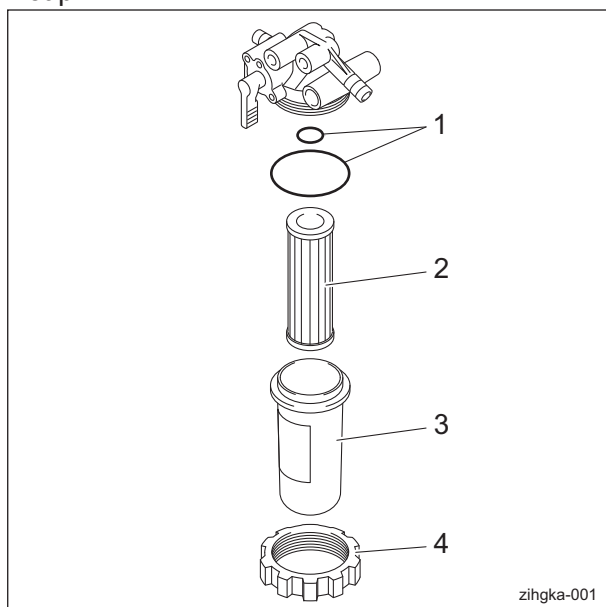

Change of Fuel Filter Element_002

1	O-ring
2	Element
3	Cup
4	Ring nut

3. Clean the inside of the filter cup with diesel fuel.

Important

During installation, prevent contamination with dirt or dust.

If the fuel is contaminated with dirt or dust etc., the fuel injection pump and injection nozzle will become worn.

4. Install a new fuel filter element, and then correctly install all parts in their original positions.
5. Fill up the fuel tank with fuel, and then open the fuel cock.

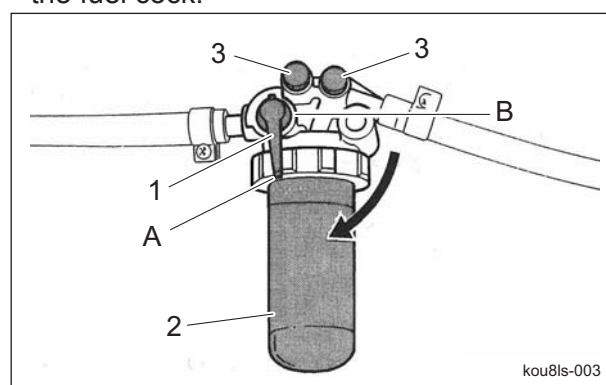

Change of Fuel Filter Element_003

1	Fuel cock
2	Fuel filter
3	Air-bleeding plug
A	ON (open)
B	OFF (close)

Note:

Air bleeding is not required since it occurs automatically.

Storage

Long-Term Storage

Follow the instructions below for long-term storage of the machine.

1. Cleaning

- Remove dirt, grass clippings, oil stains etc. completely from the main vehicle and engine.

2. Replacing oil

- Inspect and replace the engine oil, hydraulic oil and element.

3. Greasing and lubricating

- Supply oil and apply grease to appropriate parts.

4. Battery

- Loosen the battery cutoff switch to disconnect the negative battery cable. Switch the ignition key to the "ON" position and check that the charge lamp and oil pressure lamp do not turn on.

5. Fuel

- Remove the fuel from the fuel tank.

6. Tire pneumatic pressure

- Set the tire air pressure slightly higher than normal, and then place the machine on a board to avoid humidity.

7. Mower units

- When storing this machine, lower all the mower units unless a positive mechanical lock is provided.

8. Storage location

- Cover the machine and store it in a dry place where it will not be exposed to rain.

Precautions for Repair Page 7-2

Adjustment and Replacement Page 7-2

Adjustment of Parking Brake Page 7-2

Adjustment of Brake Page 7-3

Adjusting the Neutral Position of the
Piston Pump Page 7-3

Change of Fuse Page 7-5

Towing Page 7-6

Towing The Machine in An
EmergencyPage 7-6

Repair

Precautions for Repair

Warning

The chapter "Repair" in this manual describes practical measures which should be performed by a mechanic with expertise. The owner should instruct the mechanic with expertise to perform repair service for this machine.

Caution

First, learn well the operations you plan to perform.

Important

Use tools appropriate for each operation.

Important

Use Baronesse genuine parts for replacement and accessories. Our product warranty may be void if you use non-genuine parts for replacement or accessories.

Adjustment and Replacement

Adjustment of Parking Brake

Caution

Make sure that the brake wire is not cracked or damaged.

Important

Make sure that the brake is effective on slopes and that it is not applied any longer when you release it. Adjust the parking brake system whenever there is any abnormality.

1. Stop the engine.

2. Follow the steps below to adjust the parking brake.

[1] Depress the brake pedal firmly, and then pull the parking brake lever to engage the latch on the notch.

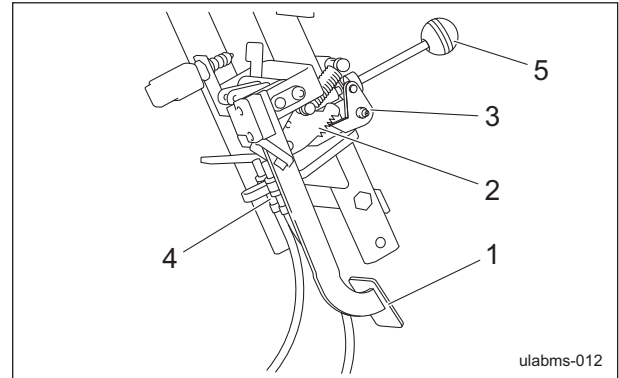

Adjustment of Parking Brake_001

1	Brake pedal
2	Notch
3	Latch
4	Adjustment bolt
5	Parking brake lever

[2] Make adjustment with the adjustment bolt so as to locate position of the latch at 3 to 4 notches from the bottom.

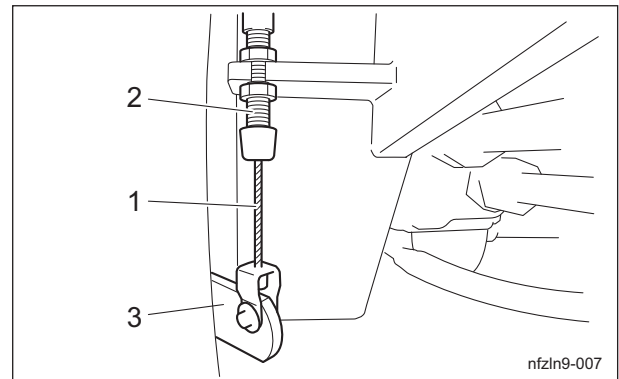

Adjustment of Parking Brake_002

1	Brake wire
2	Adjustment bolt
3	Brake lever

Adjustment of Brake

⚠ Caution

If the brake wire becomes broken, the machine will be unable to stop.
If there are cracks, damage or other defects, replace it immediately.
Adjust the brake wire if the brakes become less effective.

Important

Adjust the brake wire so that there is minimal play with the brake lever, and so that the brakes do not drag when the brake is released.

- Adjust the foot brake by tightening the adjustment bolt on the brake wire.
 - Braking force will decrease if there is more play with the brake lever, and the brake pedal will feel lighter.
 - Reducing play with the brake lever will increase braking force and make the brake pedal feel heavier.

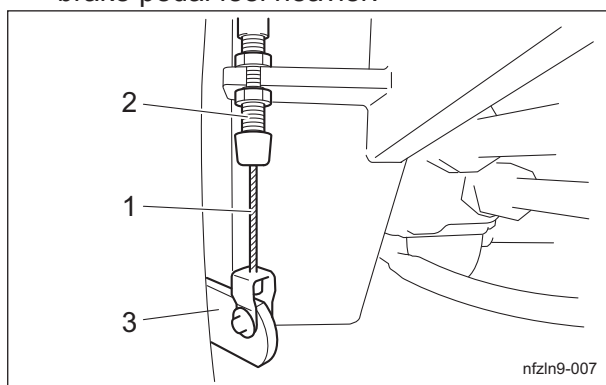

Adjustment of Brake_001

1	Brake wire
2	Adjustment bolt
3	Brake lever

- Start the engine and drive to check the following.
 - Make sure that heat is not generated in the brake area.
 - Make sure that the left and right brakes are equally effective.

⚠ Caution

It may result in an unexpected accident if the left and right brakes are not equally effective.

- If the left and right brakes are not equally effective, make fine adjustments with the adjustment bolt on the brake wire.

Break-In of Brakes

If the brake shoes or brake pads are worn, replace them with new ones.
Immediately after replacement, drive to break in the brakes if the effectiveness of the brakes is low.
While driving, lightly operate the brakes to break in the contact areas.

Adjusting the Neutral Position of the Piston Pump

⚠ Caution

Make sure not to touch rotating tires.

⚠ Caution

Be careful not to touch the muffler.

⚠ Caution

When adjusting the neutral position, pay close attention to abrupt start of the machine.
Place the jacks beneath the jack-up points, and then lift the machine until all the tires get off the ground.

Important

Make sure that there is no abnormality in the bearings of the trunnion lever. If there is an abnormality, perform a replacement before the following operation.

If the machine moves forward or backward while the traveling pedals are released, they are not set to the neutral position.
Follow the steps below to make adjustments.

- Stop the engine.
- Place the jacks beneath the jack-up points, and then lift the machine off the ground.
Use stable jack stands, and raise the machine until the tires lift off the ground.
"Jack-up Points" (Page 6-2)
- Make sure that no tires get contact with the jack stand.
- Open the hood.

Repair

5. Make sure that the length of the spring of the lever adjuster is 53.0 mm (2.09 in).
Loosen the lock nut as necessary to make adjustment.

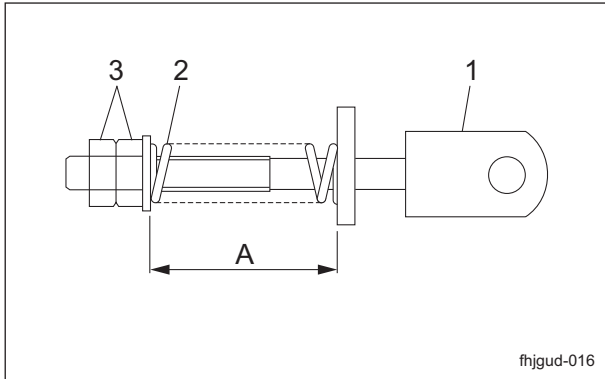

Adjusting the Neutral Position of the Piston Pump_001

1	Lever adjustment bracket
2	Spring
3	Lock nut
A	53.0 mm (2.09 in)

6. Adjust the neutral position.

Follow these steps to adjust the neutral position.

- When the tire moves in the direction of forward travel, slide the cam lever in direction A.
- When the tire moves in the direction of backward travel, slide the cam lever in direction B.

[1] Make sure that the engine has stopped.

[2] Turn the cam lever shaft bolt counterclockwise 60 ° or up to 120 ° to loosen it.

[3] Tap the cam lever fulcrum (pipe portion) with a plastic hammer in the direction of black arrow to slide the cam lever in the direction A or B.

[4] Tighten the cam lever shaft bolt.

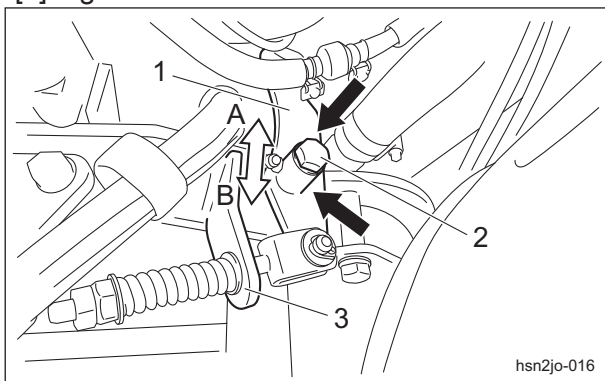

Adjusting the Neutral Position of the Piston Pump_002

1	Cam lever
2	Cam lever shaft bolt
3	Lever adjustment bracket

7. Start the engine, and rev it up to the maximum rpm.
8. Set the 2WD/3WD selector lever to the "2WD" position.
9. Check that the tires do not move.
If a tire moves even slightly, stop the engine, and then repeat steps 6. to 9.

Change of Fuse

Important

When performing maintenance on the electrical system, be sure to remove the negative battery wire.

Important

If a fuse blows, a short may have occurred within the electrical circuit. Check for the cause, such as faulty terminal connections, damaged wiring or terminals, or incorrect wiring.

Important

For fuse replacement, clean the fuse mounting area with use of compressed air before mounting the fuse.

Fuse Box

The fuse box includes spare fuses and tools.

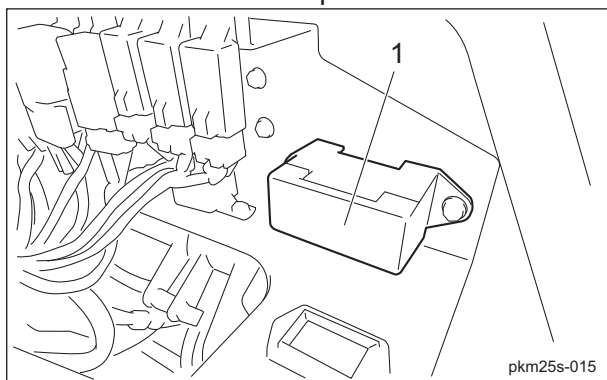

Fuse Box_001

1	Fuse box
---	----------

The machine uses a mini fuse for automobiles. Replace an old fuse with a new fuse of the specified capacity.

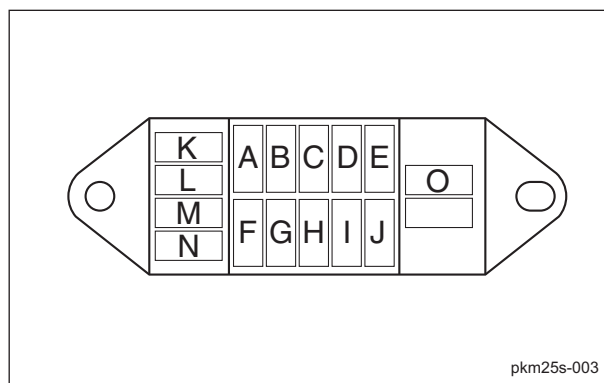

Fuse Box_002

A	5 A	Glow lamp timer
B	5 A	Glow lamp
C	5 A	Charge lamp, oil pressure lamp (engine oil pressure lamp), water temperature gauge, buzzer, solenoid timer, hour meter, fuel gauge
D	15 A	Reel normal rotation solenoid, reel reverse rotation solenoid
E	15 A	(Unused)
F	10 A	Light
G	5 A	Glow lamp timer (start signal)
H	5 A	Alternator
I	5 A	Interlock (reel control)
J	5 A	Interlock (mainly start safety)
K	5 A	Spare
L	5 A	
M	10 A	
N	15 A	
O		Tool

Fusible Link

Fuse capacities of the fusible links are 30 A and 50 A.

Engine stop solenoid: 30 A

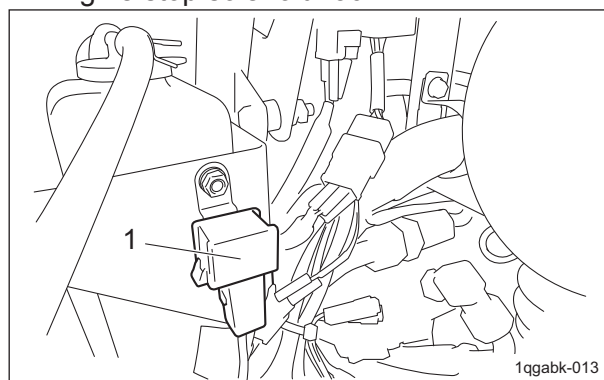

Fusible Link_001

1	Fusible link (30 A)
---	---------------------

Repair

Battery: 50 A

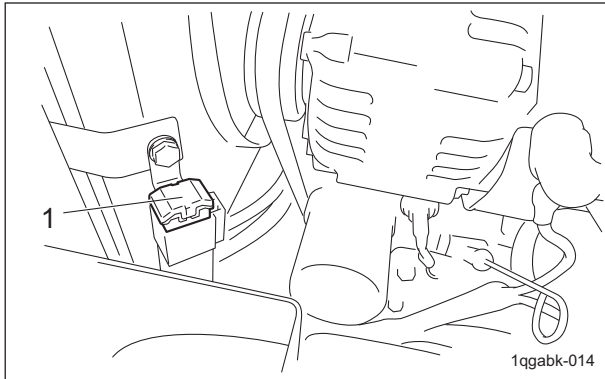

Fusible Link_002

1	Fusible link (50 A)
---	---------------------

Towing

Towing The Machine in An Emergency

If the machine does not travel due to engine trouble, etc., you can move it in the following ways:

- Pushing by hand
- Towing (See the following procedure.)

⚠ Caution

Before towing, check that the brake is applied effectively.

Important

Before starting the engine, be sure to close the unload valves.

Important

Do not touch the unload valve except when towing the machine.

Important

When towing the machine, travel at a speed no more than 3.0 km/h.
In addition, do not tow the machine for more than 3 minutes.

If the towing speed is too fast or there is excessive movement, the pump or motor will be damaged.

The unload valves are located under the floor panel.

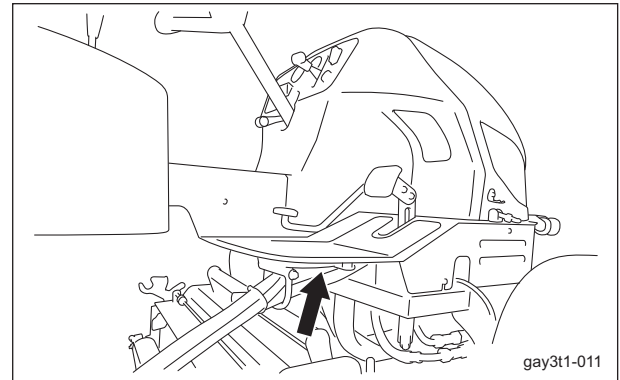

Towing The Machine in An Emergency_001

1. Stop the engine.
2. Apply the parking brake.
3. Chock the wheels.
4. Secure the machine with ropes.

Front side

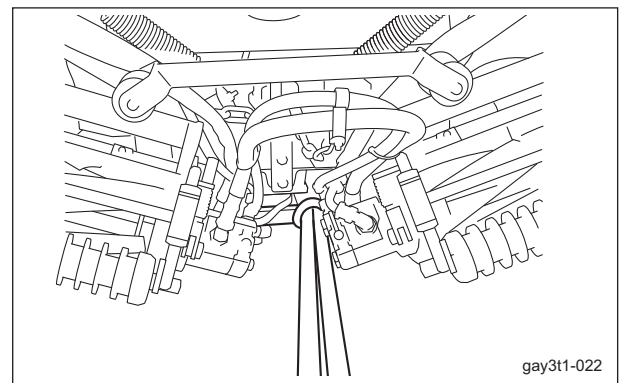

Towing The Machine in An Emergency_002

Rear side

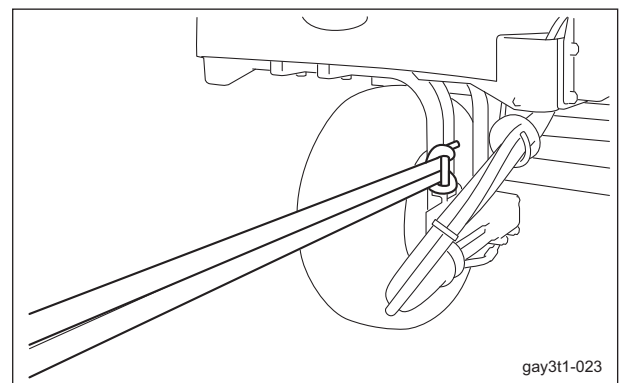

Towing The Machine in An Emergency_003

5. Set the 2WD/3WD selector lever to the "2WD" position.

Important

For unloading, be sure to open the two unload valves.

Opening only one unload valve will cause the hydraulic system to malfunction.

6. Loosen the lock nut on each of the two unload valves.
7. Tighten the two bolts to compress the unload valve operating pins and open the unload valves.

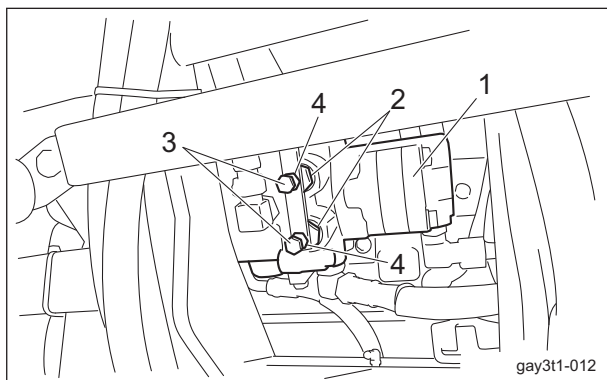

Towing The Machine in An Emergency_004

1	Piston pump
2	Unload valve
3	Bolt
4	Lock nut

8. Remove the wheel stoppers.
9. Depress the brake pedal to release the parking brake.

Warning

While towing, always keep your foot on the brake pedal and depress the brake pedal at any time to stop.

10. Tow the machine slowly.

Appended Table

Tightening Torques Page 8-2
 Standard Tightening Torques Page 8-2
 Principal Tightening Torques Page 8-5

Maintenance Schedule Page 8-6

List of Adjusted Value Page 8-9

Appended Table

Tightening Torques

Important

Refer to the Tightening Torque table.
Note that the Baroness product warranty may not apply to defects caused by incorrect or overtorque tightening, etc.

Standard Tightening Torques

Bolts and Nuts

Important

A number of bolts are used in each part of this machine.
Be sure to re-tighten the bolts and nuts, because they may be loosened at the earlier stage of the use.

As to the bolts and nuts without any special instruction, tighten them in appropriate tightening torque with proper tool.

Too much tightening may cause the looseness or damage of the screw.

The strength of tightening is determined by types of screws, strength, the friction of thread face or base face and others.

The table below is for the galvanized or parkerized bolts.

In case that the strength of internal thread is weak, it is not applied.

Do not use rusty or sand attached "screw."

Otherwise, it may cause insufficient tightening even if you apply the specified tightening torque.

The friction of the screw face becomes higher and the tightening torque is canceled out by the friction, therefore sufficient tightening cannot be applied.

If "screw" is wet by water or oil, do not tighten it with normal tightening torque.

If the screw is wet, the torque coefficient will get smaller and it may result in too much tightening.

Too much tightening may cause looseness by the screw stretched or result in damage.



Do not use a bolt experienced too much burden.

Using the impact wrench requires the skill.

Do exercise as much as possible for steady tightening.

Appended Table

Nominal diameter	General bolt		
	Strength classification 4.8		
	 tib3yb-001		
	N-m	kgf-cm	lb-in
M5	3 - 5	30.59 - 50.99	26.55 - 44.26
M6	7 - 9	71.38 - 91.77	61.96 - 79.66
M8	14 - 19	142.76 - 193.74	123.91 - 168.17
M10	29 - 38	295.71 - 387.49	256.68 - 336.34
M12	52 - 67	530.24 - 683.20	460.25 - 593.02
M14	70 - 94	713.79 - 958.52	619.57 - 831.99
M16	88 - 112	897.34 - 1142.06	778.89 - 991.31
M18	116 - 144	1,182.85 - 1,468.37	1,026.72 - 1,274.54
M20	147 - 183	1,498.96 - 1,866.05	1,301.10 - 1,619.73
M22	295	3,008.12	2,611.05
M24	370	3,772.89	3,274.87
M27	550	5,608.35	4,868.05
M30	740	7,545.78	6,549.74

Nominal diameter	Heat-treated bolt					
	Strength classification 8.8			Strength classification 10.9		
	 tib3yb-002			 tib3yb-003		
	N-m	kgf-cm	lb-in	N-m	kgf-cm	lb-in
M5	5 - 7	50.99 - 71.38	44.26 - 61.96	7 - 10	71.38 - 101.97	61.96 - 88.51
M6	8 - 11	81.58 - 112.17	70.81 - 97.36	14 - 18	142.76 - 183.55	123.91 - 159.32
M8	23 - 29	234.53 - 295.71	203.57 - 256.68	28 - 38	285.52 - 387.49	247.83 - 336.34
M10	45 - 57	458.87 - 581.23	398.30 - 504.51	58 - 76	591.43 - 774.97	513.36 - 672.68
M12	67 - 85	683.20 - 866.75	593.02 - 752.34	104 - 134	1,060.49 - 1,366.40	920.50 - 1186.03
M14	106 - 134	1,080.88 - 1,366.40	938.21 - 1,186.03	140 - 188	1,427.58 - 1,917.04	1,239.14 - 1,663.99
M16	152 - 188	1,549.94 - 1,917.04	1,345.35 - 1,663.99	210 - 260	2,141.37 - 2,651.22	1,858.71 - 2,301.26
M18	200 - 240	2,039.40 - 2,447.28	1,770.20 - 2,124.24	280 - 340	2,855.16 - 3,466.98	2,478.28 - 3,009.34
M20	245 - 295	2,498.27 - 3,008.12	2,168.50 - 2,611.05	370 - 450	3,772.89 - 4,588.65	3,274.87 - 3,982.95
M22	-	-	-	530	5,404.41	4,691.03
M24	-	-	-	670	6,831.99	5,930.17
M27	-	-	-	1,000	10,197.00	8,851.00
M30	-	-	-	1,340	14,628.78	11,860.34

Note:
The same values are applied to "fine screw thread."

Appended Table

Hydraulic Hose

The tightening torques for union joints and union adaptors with parallel pipe threads (G, PF) are shown in the table below.

A union joint or adaptor will not become loose or leak as long as it is tightened by the specified torque.

If fluid leaks from the sealed portion, do not attempt to tighten the union joint or adaptor forcibly.

Examine whether any foreign matter or scratches are present on the seat surface.

Tightening a union joint or adaptor forcibly could damage the connection of the joints.

When tightening a union joint or adaptor, use a torque wrench where possible and firmly tighten it by an appropriate torque.

Nominal diameter of the hose size	Nominal diameter of the parallel pipe threads (G, PF)	Tightening torque		
		N-m	kgf-cm	lb-in
6	1/4	24.50	250	221.28
9	3/8	49.03	500	564.91
12	1/2	58.84	600	677.89
15	3/4	117.68	1200	1,355.78
19	3/4	117.68	1200	1,355.78
25	1	137.30	1400	1,581.74
32	1-1/4	166.72	1700	1,920.69
38	1-1/2	205.94	2100	2,372.61
50	2	245.17	2500	2,824.54

Fittings with Parallel Threads (O-Ring Seal Type)

The tightening torques for fittings with parallel threads (O-ring seal method) are shown in the table below.

Tightening the fitting forcibly with a spanner or other such tool to secure it to a set position could damage the fitting, its washers, and other parts. Be sure to tighten the fitting to the torque appropriate to its size.

Nominal diameter of thread	Tightening torque		
	N-m	kgf-cm	lb-in.
1/4	34.32 - 49.03	350 - 500	309.79 - 442.55
3/8	68.65 - 78.45	700 - 800	619.57 - 708.08
1/2	98.07 - 117.68	1000 - 1200	885.10 - 1,062.12
3/4	147.10 - 176.52	1500 - 1800	1,327.65 - 1,593.18
1	245.17 - 274.59	2500 - 2800	2,212.75 - 2,478.28
1-1/4	294.20	3000	2,655.30
1-1/2	294.20	3000	2,655.30
2	392.27	4000	3,540.40

Appended Table

Principal Tightening Torques

Tightening Torque by Model

LM331

Tighten the following bolts and nuts at the torque specified in the table.

For thread locking adhesive, apply a middle strength thread locker (ThreeBond 1322 or equivalent anaerobic sealant).

Location		Code	Part name	Tightening torque			Thread locking adhesive
				N-m	kgf-cm	lb-in	
Front wheel	Wheel mounting base	K0160000492	NUT, SPECIAL P1.5 M24	180 - 200	1835.46 - 2039.40	1593.18 - 1770.20	○
	Wheel	K0011120302	BOLT, HT P1.5 M12-30	67 - 85	683.20 - 866.75	593.02 - 752.34	-
Brake pedal		K0010080252	BOLT, HT M8-25	23 - 38	234.53 - 387.49	203.57 - 336.34	-
Rear wheel	Wheel mounting base	K0138240002	NUT, HIGH SLOTTED P1.5 M24	180 - 200	1835.46 - 2039.40	1593.18 - 1770.20	-
	Wheel	K0011120302	BOLT, HT P1.5 M12-30	67 - 85	683.20 - 866.75	593.02 - 752.34	-
Steering shaft housing		K0010100402	BOLT, HT M10-40	45 - 76	458.87 - 774.97	398.30 - 672.68	-
Steering shaft lid		K0010100252	BOLT, HT M10-25	45 - 76	458.87 - 774.97	398.30 - 672.68	-
Engine base		K0017100252	BOLT, SMALL HT P1.25 M10-25	45 - 57	458.87 - 581.23	398.30 - 504.51	-
Pump bracket		K0010080302	BOLT, HT M8-30	23 - 38	234.53 - 387.49	203.57 - 336.34	-
Engine pulley		K0010080202	BOLT, HT M8-20	23 - 38	234.53 - 387.49	203.57 - 336.34	-
Hydraulic pump		K0010120502	BOLT, HT M12-50	67 - 134	683.20 - 1366.40	593.02 - 1186.03	-
Steering cylinder		LM331--0722Z2	BOLT, STEPPED M12	-	-	-	○
		K0000080202	BOLT, M8-20	-	-	-	○
Electric components for engine		-	Starter B terminal (M8)	5.9 - 11.7	60.16 - 119.30	52.22 - 103.56	-
		-	Alternator B terminal (M6)	5.9 - 9.8	60.16 - 99.93	52.22 - 86.74	-
		-	Glow plug connection terminal nut (M4)	1.0 - 1.8	10.20 - 18.35	8.85 - 15.93	-
ROPS		K0010120402	BOLT, HT M12-40	104 - 134	1,060.49 - 1366.40	920.50 - 1186.03	-

Appended Table

Maintenance Schedule

LM331

- . . . Inspect, adjust, supply, clean (first time)
- . . . Inspect, adjust, supply, clean
- ▲ . . . Replace (first time)
- △ . . . Replace

Maintenance Item		Before Work	After Work	Every Week	Every 50 hrs.	Every 100 hrs.	Every 200 hrs.	Every 250 hrs.	Every 400 hrs.	Every 500 hrs.	Every 800 hrs.	Every 1500 hrs.	Every 3000 hrs.	every month	Every 6 months	Every year	Every 2 years	Every 4 years	When Required	Remarks
*3	Check engine oil level	○																		
*3	Check fuel level	○																		
*3	Check coolant level	○																		
*3	Check fan belt	○																		
*3	Open air cleaner evacuator valve to remove dust	○		○																Open valve every week or daily in dusty conditions
	Check hydraulic oil	○																		
	Check hydraulic hoses (Moving part)	○																		
	Check tire	○																		
	Check V belt	○																		
	Check traveling pedal motion	○																		
	Check brake function	○																		
	Check brake wire	○																		
	Check brake pedal play	○																		
	Check liquid leakage	○																		
	Check damaged parts	○																		
	Check bolts and nuts	○																		
	Check light illumination	○																		
	Check meters and lamps	○																		By starting the engine
	Check interlock system safety function	○																		By starting the engine
	Check steering wheel motion	○																		By starting the engine
	Check mower arm motion	○																		By starting the engine
	Clean machine exterior		○																	
	Clean engine area		○																	
	Clean radiator screen		○																	

Appended Table

Maintenance Item	Before Work	After Work	Every Week	Every 50 hrs.	Every 100 hrs.	Every 200 hrs.	Every 250 hrs.	Every 400 hrs.	Every 500 hrs.	Every 800 hrs.	Every 1500 hrs.	Every 3000 hrs.	every month	Every 6 months	Every year	Every 2 years	Every 4 years	When Required	Remarks
Clean radiator core		○																	
Clean oil cooler core		○																	
Check electrical wiring				●	○														
Check wheel mounting bolt				●	○														
Grease and Lubricate				○	○										○				Maintenance schedules differ according to greasing points
*2.*3 Check fuel hoses and clamp bands				○															
*3 Change engine oil				▲	△														
*3 Replace oil filter cartridge				▲		△													
*2.*3 Clean air cleaner outer element (Replace the element after 6-time cleaning)					○										△				Replace every 6 cleanings or every year whichever comes earlier Air cleaner should be cleaned more often in dusty conditions than in normal conditions
Replace hydraulic oil					▲				△										
Replace hydraulic oil filter					▲				△										
*4 Check exterior of battery					○								○						Every 100 hours or every month whichever comes earlier
*4 Clean exterior of battery					○								○						Every 100 hours or every month whichever comes earlier
*4 Check mounting bracket of battery					○								○						Every 100 hours or

Appended Table

Appended Table

Maintenance Item		Before Work	After Work	Every Week	Every 50 hrs.	Every 100 hrs.	Every 200 hrs.	Every 250 hrs.	Every 400 hrs.	Every 500 hrs.	Every 800 hrs.	Every 1500 hrs.	Every 3000 hrs.	every month	Every 6 months	Every year	Every 2 years	Every 4 years	When Required	Remarks	
*4	Check mounting bracket of battery					○								○							every month whichever comes earlier
*4	Check looseness and corrosion of battery terminals					○								○							Every 100 hours or every month whichever comes earlier
*4	Check battery fluid level					○								○							Every 100 hours or every month whichever comes earlier
*3	Adjust fan belt tension					○															
*3	Clean fuel filter pot					○															
	Draining of water separator					○															
*2	Check intake air line (air cleaner hose)						○														
*3	Check radiator hoses and clamp bands						○								○						Every 200 hours or 6 months whichever comes earlier
	Check hydraulic hoses (Fixed part)						○									○					Every 200 hours or every year whichever comes earlier
	Grease mower unit hydraulic motor shafts							○													
*2.*3	Replace fuel filter element								△												
	Clean water separator								○												
	Clean water jacket and radiator interior									○											
*3	Replace fan belt									△											
*1	Check valve clearance										○										
*1.*2	Check injection nozzle											○									
*1.*2	Check injection pump												○								
*3	Change radiator coolant (L.L.C.)																△				

Appended Table

Maintenance Item		Before Work	After Work	Every Week	Every 50 hrs.	Every 100 hrs.	Every 200 hrs.	Every 250 hrs.	Every 400 hrs.	Every 500 hrs.	Every 800 hrs.	Every 1500 hrs.	Every 3000 hrs.	every month	Every 6 months	Every year	Every 2 years	Every 4 years	When Required	Remarks
*3	Replace radiator hoses and clamp bands																	△		
*1.*2.*3	Replace fuel hoses and clamps																	△		
*2	Replace intake air line (air cleaner hose)																	△		
	Replace hydraulic hoses (Moving part)																	△		
	Replace hydraulic hoses (Moving part) relating to steering																	△		
	Replace hydraulic hoses (Fixed part)																		△	
	Adjust brakes																			○
	Replace brake shoe																			△
	Replace brake cables																			△
*4	Replace battery																			△

- *1: Consult your local Baroness Dealer or local KUBOTA Dealer for this service.
- The items above (*2 marked) are registered as emission related critical parts by KUBOTA in the U.S. EPA nonroad emission regulation.
As the engine owner, you are responsible for the performance of the required maintenance on the engine according to the above instruction.
Please see the Engine's Warranty Statement in detail.
- *3: Refer to the Engine's Owner's Manual.
- *4: Refer to the Battery's Owner's Manual.
- The values for consumables are not guaranteed.
- Be sure to replace hydraulic hoses for steering cylinder and hydraulic hoses for hydraulic motor of wheel relating to steering every two years.

List of Adjusted Value

Fan belt		10 mm (0.39 in)	Belt slack when belt pressed with 98 N (10 kgf) at the middle point.
Mower stabilizer spring	#2, #3	140.0 mm (5.51 in)	Total length of spring
	#1	60.0 mm (2.36 in)	Total length of spring
Hydraulic pump drive belt		30.0 - 35.0 mm (1.18 - 1.38 in)	Total length of spring
Piston pump		53.0 mm (2.09 in)	Total length of spring (lever adjuster)

Appended Table

BARONESS[®]
Quality on Demand

 **KYOEISHA CO., LTD.**
Head Office 1-26, Miyuki-cho, Toyokawa-city, Tel :+81-533-84-1390
Aichi-pref, 442-8530 JAPAN Fax:+81-533-84-1220