

LH62·LH66

Multi Configuration Mower Unit

Owner's Operating Manual

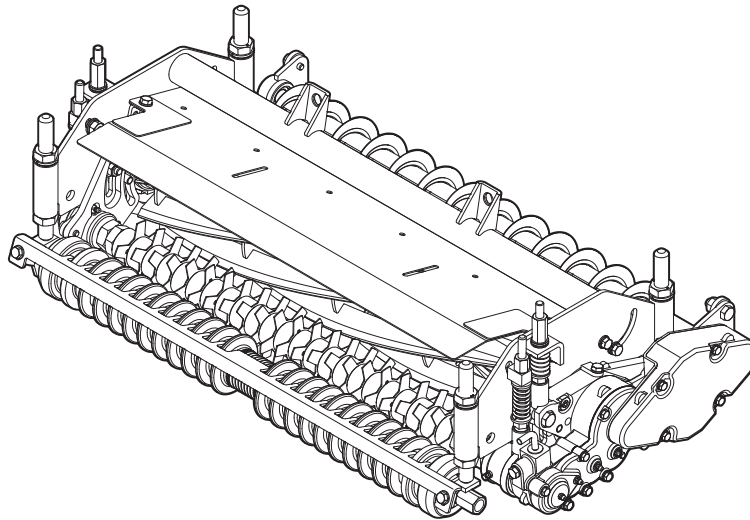

Serial No. LH62 : 11407- • LH66 : 10461-

"Required reading"
Read this manual before using the machine.

BARONESS[®]
Quality on Demand

Original Instructions Ver.1.7

Greeting

Thank you for purchasing the Baroness product. This manual describes the proper handling, adjustment, and inspection of your product. We hope you will use the product safely, and take advantage of its best performance. For details on the handling, adjustment and inspection of the main vehicle, refer to the Owner's Operating Manual for the main vehicle.

LH66: <https://doc.baroness-international.com/manuals/LH66>

QR Code

A QR code for this mower unit is printed on the serial number plate.

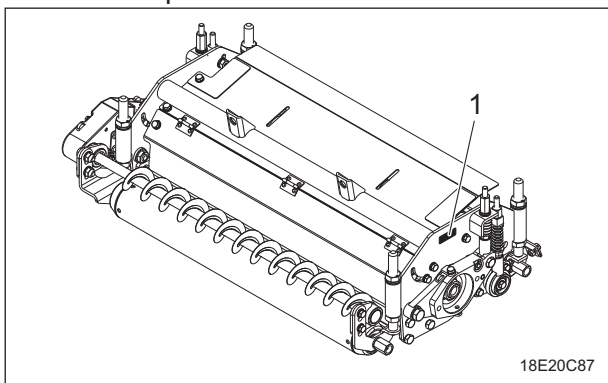

QR Code_001

1	QR code
---	---------

Scan the QR code with your smartphone for easy access to Baroness Manual Reference Service where you can browse Owner's Operating Manual and Parts Catalog.
 LH62: <https://doc.baroness-international.com/manuals/LH62>



QR Code_003



QR Code_002

Read this manual carefully to ensure that you thoroughly understand how to properly operate and maintain the product, and to avoid causing injury to yourself or others.

The operator is responsible for operating the product properly and safely.

Maintenance service for this machine should be performed by a mechanic with expertise.

If you have any questions concerning maintenance or genuine parts, please contact a Baroness dealer or Kyoeshia.





When making inquiries about your product, please specify the model and serial number.

When loaning or transferring the product, please also provide this manual together with the product.

Kyoeisha Co., Ltd.

Warning Symbols

This manual uses the following warning symbols for handling precautions that are important for your safety.

 <p style="text-align: center; font-size: small;">696cq5-001</p>	<p>Warning symbol</p>
<p>This symbol indicates the articles regarding “Danger,” “Warning,” or “Caution.” Those articles describe important safety precautions and so read them carefully to understand completely before operating the machine. Failure to adequately follow these safety precautions may cause an accident.</p>	
<p> Danger</p> <p>This symbol indicates that serious injury or death will occur if the warning is ignored.</p> <p> Warning</p> <p>This symbol indicates that serious injury or death may occur if the warning is ignored.</p> <p> Caution</p> <p>This symbol indicates that injury or damage to property may occur if the warning is ignored.</p> <p>Important</p> <p>This symbol indicates precautions on the mechanism of the machine.</p>	

Introduction

Precautionary Statement

 Caution

The information described in this manual is subject to change for improvement without prior notice.

When replacing parts, be sure to use genuine Baroness parts or parts designated by Kyoisha.

Note that the Baroness product warranty may not apply to defects caused by the use of parts from other companies.

Prior to use, carefully read the following manuals to thoroughly understand the contents for safe and correct operation.

- Baroness Owner's Operating Manual

Purpose

This mower unit is intended for cutting turf grass at golf courses.

Do not use this machine in any way other than its intended purpose, and do not modify the machine.

Operating this mower unit for other purposes and modifying it may be very dangerous and may cause damage to the machine.

Safety	Page 1-1
Safe Operating Practices	Page 1-2
Disposal	Page 2-1
Recycle and Waste Disposal	Page 2-2
Product Overview	Page 3-1
Specifications	Page 3-2
Names of Each Section	Page 3-4
Regulation Decals	Page 3-5
Safety Signs and Instruction Signs	Page 3-5
Operation Decals	Page 3-6
Description of Functions	Page 4-1
Groomer Clutch Lever	Page 4-2
Handling Instructions	Page 5-1
Handling Precautions	Page 5-2
Inspection and Cleaning	Page 5-2
Maintenance	Page 6-1
Precautions for Maintenance	Page 6-2
Greasing	Page 6-2
Maintenance Work	Page 6-5
Storage	Page 6-17
Appended Table	Page 7-1
Tightening Torques	Page 7-2
Maintenance Schedule	Page 7-5
List of Adjusted Values	Page 7-6

Contents

Safe Operating Practices Page 1-2

Safety

Failure to adequately follow these safety precautions may cause an accident resulting in injury or death.

⚠ Danger

This product is designed to ensure safe operation and has been tested and inspected thoroughly before shipment from the factory. The product is equipped with safety devices to prevent accidents.

However, whether the product demonstrates its original performance level depends on the manner in which it is operated and handled, as well as the manner in which it is managed on a daily basis.

Inappropriate use or management of the product may result in injury or death.

Observe the following safety instructions to ensure safe operation.

Safe Operating Practices

Read Safe Operating Practices described in the Owner's Operating Manual of Baroness main vehicle equipped with this mower unit thoroughly.

Recycle and Waste Disposal Page 2-2

About RecyclePage 2-2

About Waste Disposal Page 2-2

Disposal

Recycle and Waste Disposal

About Recycle

Recycling battery etc. is recommended for environmental conservation and economical use of resources.

It may be required by local laws.

About Waste Disposal

Make sure that waste generated when servicing or repairing the machine is disposed of in accordance with local regulations. (e.g. waste oil, antifreeze, rubber products, and wires etc.)

Specifications Page 3-2

Specifications List Page 3-2

Features of The MC Mower Unit Page 3-4

Names of Each Section Page 3-4**Regulation Decals Page 3-5**

Positions of Regulation Decals Page 3-5

Description of Regulation Decals Page 3-5

Safety Signs and Instruction Signs Page 3-5About Safety Decals and Instruction
Decals Page 3-5Positions of Safety Decals and
Instruction Decals Page 3-5Description of Safety Decals and
Instruction Decals Page 3-5**Operation Decals Page 3-6**

Positions of Operation Decals Page 3-6

Description of Operation Decals Page 3-6

Product Overview

Specifications

Specifications List

LH62

Model		LH62			
Name		Multi Configuration Mower Unit			
Type		Base unit (incl. two weights)		With groomer	
Dimensions	Total length	451 mm	17.76 in	←	←
	Total width	771 mm	30.35 in	778 mm	30.63 in
	Total height	292 mm	11.50 in	←	←
Weight	Mower Unit	56.0 kg	123.46 lb	61.0 kg	134.48 lb
	Weight (one piece)	2.0 kg	4.41 lb	-	-
	Groomer	-	-	9.0 kg	19.84 lb
	CR brush	-	-	-	-
	Groomer + CR brush	-	-	-	-
Operating width (Mowing width)		557.5 mm	22 in	←	←
Operating height (Mowing height)		8.0 - 45.0 mm	0.315 - 1.772 in	←	←
Number of Blades		9		←	
Diameter of the reel cutter		163 mm	6.4 in	←	←

Model		LH62			
Name		Multi Configuration Mower Unit			
Type		With CR brush type A		With groomer and CR brush type B	
Dimensions	Total length	475 mm	18.70 in	←	←
	Total width	766 mm [784 mm]	30.16 in [30.87 in]	784 mm	30.87 in
	Total height	292 mm	11.50 in	←	←
Weight	Mower Unit	57.0 kg [58.0 kg]	125.66 lb [127.87 lb]	65.0 kg	143.30 lb
	Weight (one piece)	-	-	-	-
	Groomer	-	-	-	-
	CR brush	5.0 kg [6.0 kg]	11.02 lb [13.23 lb]	-	-
	Groomer + CR brush	-	-	13.0 kg	28.66 lb
Operating width (Mowing width)		557.5 mm	22 in	←	←
Operating height (Mowing height)		8.0 - 45.0 mm	0.315 - 1.772 in	←	←
Number of Blades		9		←	
Diameter of the reel cutter		163 mm	6.4 in	←	←

The values in the brackets [] are for CR brush type B.

Product Overview

LH66

Model		LH66			
Name		Multi Configuration Mower Unit			
Type		Base unit (incl. two weights)		With groomer	
Dimensions	Total length	451 mm	17.76 in	←	←
	Total width	874 mm	34.41 in	880 mm	34.65 in
	Total height	292 mm	11.50 in	←	←
Weight	Mower Unit	61.0 kg	134.48 lb	66.0 kg	145.50 lb
	Weight (one piece)	2.0 kg	4.41 lb	-	-
	Groomer	-	-	9.0 kg	19.84 lb
	CR brush	-	-	-	-
	Groomer + CR brush	-	-	-	-
Operating width (Mowing width)		660 mm	26 in	←	←
Operating height (Mowing height)		8.0 - 45.0 mm	0.315 - 1.772 in	←	←
Number of Blades		7 • 9		←	
Diameter of the reel cutter		163 mm	6.4 in	←	←

Model		LH66			
Name		Multi Configuration Mower Unit			
Type		With CR brush type A		With groomer and CR brush type B	
Dimensions	Total length	474 mm	18.66 in	←	←
	Total width	868 mm [887 mm]	34.17 in [34.92 in]	887 mm	34.92 in
	Total height	292 mm	11.50 in	←	←
Weight	Mower Unit	62.0 kg [63.0 kg]	136.68 lb [138.89 lb]	70.0 kg	154.32 lb
	Weight (one piece)	-	-	-	-
	Groomer	-	-	-	-
	CR brush	5.0 kg [6.0 kg]	11.02 lb [13.23 lb]	-	-
	Groomer + CR brush	-	-	13.0 kg	28.66 lb
Operating width (Mowing width)		660 mm	26 in	←	←
Operating height (Mowing height)		8.0 - 45.0 mm	0.315 - 1.772 in	←	←
Number of Blades		7 • 9		←	
Diameter of the reel cutter		163 mm	6.4 in	←	←

The values in the brackets [] are for CR brush type B.

Product Overview

Features of The MC Mower Unit

1. Equipped with a 6.4-inch (163 mm) - diameter reel cutter (cutting cylinder).
2. Blade engagement can be adjusted by changing the reel cutter (cutting cylinder) position without changing the position and angle of the bed knife (bottom blade), and therefore the bed knife attitude does not change due to wear of the reel cutter.
3. The angle of the bed knife (bottom blade) can be adjusted according to the lawn conditions.
4. The front roller is a grooved roller that will not press down the lawn.
5. Grass clippings can be discharged either forward or backward.
6. The grass catcher can be installed.
7. The groomer can be installed.
8. The CR brush can be installed onto the rear roller.
9. The groomer and CR brush can be installed at the same time.
10. The scraper can be installed on the front and rear roller.

1	Reel cover
2	Reel cutter
3	Bed knife
4	Front roller
5	Rear roller
6	Groomer
7	Scraper
8	CR brush

Names of Each Section

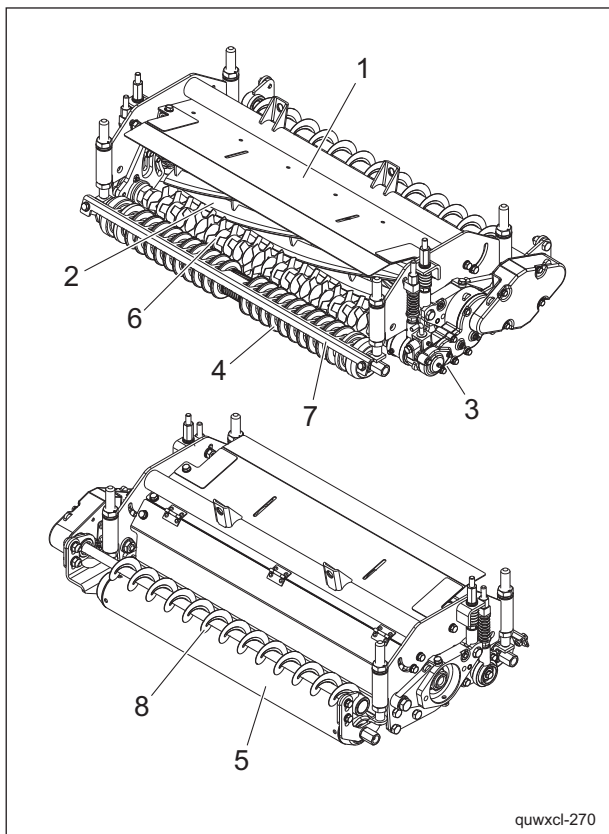

Names of Each Section_001

Regulation Decals

Positions of Regulation Decals

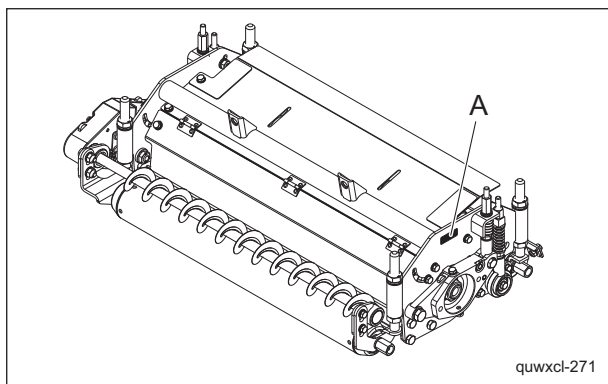

Positions of Regulation Decals_001

A	Serial number plate
---	---------------------

Positions of Safety Decals and Instruction Decals

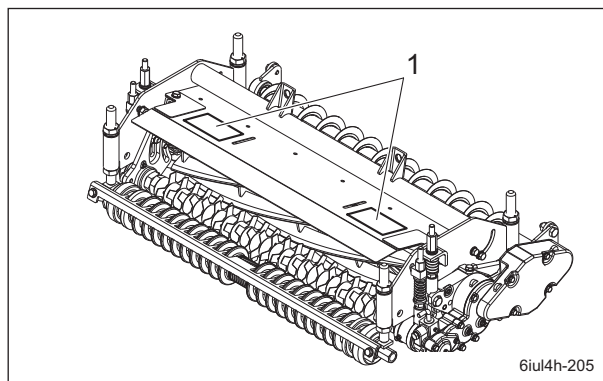

Positions of Safety Decals and Instruction Decals_001

1	Caution to mutilation decal
---	-----------------------------

Description of Regulation Decals

Serial Number Plate

The serial number plate indicates the model and serial number of the machine. A QR code is also printed for browsing Owner's Operating Manual and Parts Catalog.

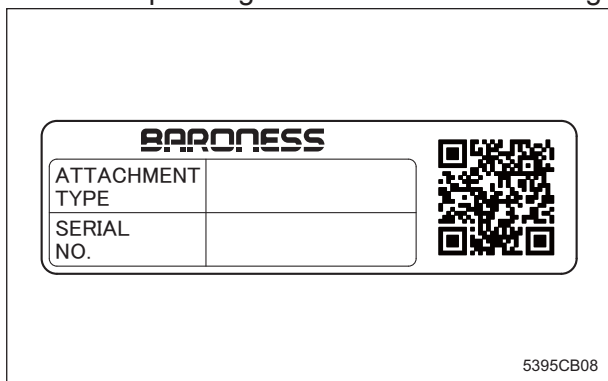

Serial Number Plate_001

Description of Safety Decals and Instruction Decals

Caution to Mutilation Decal

K4205001600
DECAL, CAUTION TO MUTILATION



May cut your hand or leg - Stop the cutter rotation and engine. Otherwise you may get injured.

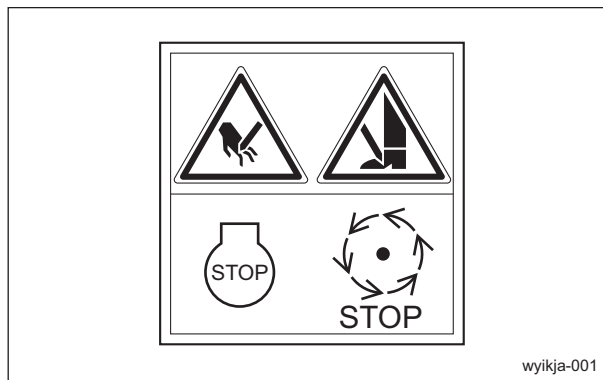

Caution to Mutilation Decal_001

Safety Signs and Instruction Signs

About Safety Decals and Instruction Decals

Important

Safety decals and instruction decals are attached to this mower unit. Make sure that decals are preserved in their entirety. If they are damaged, become dirty, or peel off, replace them with new ones.

Part numbers for decals that need to be replaced are listed in the parts catalog. Order them from a Baroness dealer or Kyoeshia.

Product Overview

Operation Decals

Positions of Operation Decals

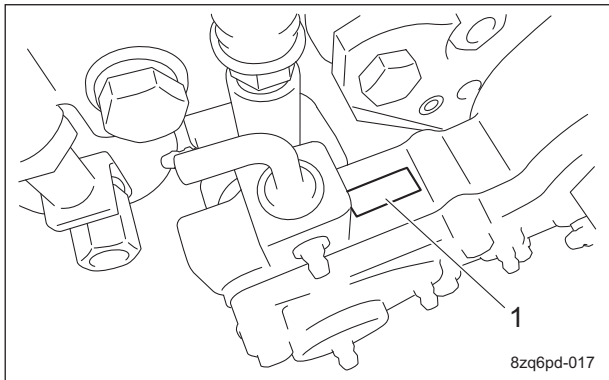

Positions of Operation Decals_001

1	Sticker, ON/OFF
---	-----------------

Description of Operation Decals

ON/OFF Mark A

K4203001140

DECAL, ON/OFF A

It shows ON/OFF of reel clutch.

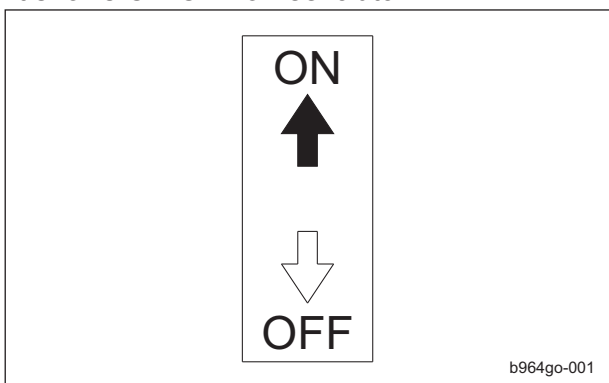

ON/OFF Mark A_001

Description of Functions

Groomer Clutch Lever Page 4-2

Description of Functions

Description of Functions

Groomer Clutch Lever

Note:

Depending on the specifications, this function may not be available.

Caution

The lever should be operated while the engine is stopped, and adjusted to the position suitable for your work.

Important

Do not pull the groomer clutch lever upward. Otherwise, the groomer clutch lever will get out of the groomer case and the steel ball will fall into the case.

The groomer clutch lever is located on the groomer installed on each mower unit and is used during grooming. When the groomer clutch lever is set to the "ON" position, the groomer rotates. When the groomer clutch lever is set to the "OFF" position, the groomer stops rotating. When grooming is not being performed, be sure to set the lever to the "OFF" position.

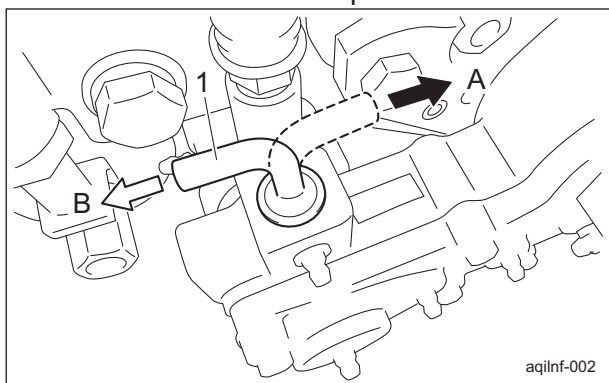

Groomer Clutch Lever_001

1	Groomer clutch lever
A	ON
B	OFF

Handling Instructions

Handling Precautions Page 5-2

Inspection and Cleaning Page 5-2

Reel Cutter (Cutting Cylinder) and
Bed Knife (Bottom Blade) Page 5-2

Cover Page 5-2

Belt Page 5-2

Roller Page 5-3

Groomer Page 5-3

CR brush Page 5-3

Scraper Page 5-3

Bolts and Nuts Page 5-4

Mower Unit Page 5-4

Handling Instructions

Handling Precautions

Important

This manual contains descriptions for handling the mower unit.

For details on handling the main vehicle, refer to this manual and the Owner's Operating Manual for the main vehicle.

Inspection and Cleaning

Reel Cutter (Cutting Cylinder) and Bed Knife (Bottom Blade)

Inspection of Reel Cutter (Cutting Cylinder) and Bed Knife (Bottom Blade)

Caution

Wear gloves when touching edged tools to avoid cutting your hands.

The reel cutter (cutting cylinder) and bed knife (bottom blade) may become dull due to frequent use, objects crushed during mowing, or damage caused during transportation. Inspect the reel cutter (cutting cylinder) and bed knife (bottom blade), and if necessary, adjust the blade engagement, perform back lapping, or sharpen or replace the reel cutter (cutting cylinder) and the bed knife (bottom blade).

1. Check to see whether or not the edge of the reel cutter (cutting cylinder) and the bed knife (bottom blade) are too blunt to cut.
2. Make sure that the reel cutter (cutting cylinder) and the bed knife (bottom blade) are not cracked.
3. Check to see how much the reel cutter (cutting cylinder) and the bed knife (bottom blade) are worn.
4. Make sure that the reel cutter (cutting cylinder) and the bed knife (bottom blade) have not changed color due to heat from grinding.
5. Check to see whether or not the second edge face (relief) remains at the point of reel cutter (cutting cylinder).
6. Make sure that the welding between the reel cutter (cutting cylinder) and the disc has not come off.

Cover

Inspection of Covers

Warning

If you have removed the covers during inspection, be sure to securely install them in their original positions.

If a cover remains removed, the operator may come into contact with rotating parts or belts and foreign objects may fly off, possibly resulting in injuries.

1. Make sure that there is no wear or deterioration of the reel cover and all other covers.
2. Make sure that there is no damage to the reel cover and all other covers.
3. Make sure that there is no interference with moving parts due to deformation of the reel cover and all other covers.
4. Make sure that the reel cover and all other covers are installed in their appropriate positions.

Belt

Inspection of Belt

Caution

The engine must be stopped when the belt is inspected.

Caution

If you have removed the cover during inspection, make sure that you replace it in the original position securely.

If the cover remains removed, the operator may come in contact with the rotating objects or belt, possibly resulting in injuries.

1. Press the middle of the belt with your finger to check the belt tension.
2. Make sure that there are no cracks, damage or abnormal wear.

Handling Instructions

Roller

Inspection of Rollers

Bearing wear due to frequent use or bearing damage caused by water infiltration may prevent the roller from rotating smoothly. Inspect the roller and, if necessary, replace parts such as oil seals and bearings.

1. Make sure that there is no abrasion nor adhesion of the roller.
2. Make sure that there is no wear of the roller shaft.
3. Make sure that there is no wear nor damage of the oil seal.
4. Make sure that there is no wear nor rust of the bearing.
5. Make sure that there is no play in the roller shaft.

Groomer

Inspection of Groomer

Note:

Depending on the specifications, this function may not be available.

The operating efficiency may be reduced due to frequent use, objects crushed during operation, or damage to vertical blades or the shaft during transportation.

In addition, bearing wear or bearing damage caused by water infiltration may prevent the shaft from rotating smoothly.

Inspect the groomer and, if necessary, replace parts such as vertical blades or bearings.

1. Make sure that the vertical blades are not cracked.
2. Check how much the vertical blades are worn.
3. Make sure that the shaft is not worn nor bent.
4. Make sure that there is no wear nor rust of the bearing.
5. Make sure that there is no play in the groomer shaft.

CR brush

Inspection of CR Brush

Note:

Depending on the specifications, this function may not be available.

Bearing wear due to frequent use or bearing damage caused by water infiltration may prevent the brush from rotating smoothly. Inspect the brush and, if necessary, replace parts such as bearings.

1. Make sure that there is no abrasion nor adhesion of the brush.
2. Make sure that there is no wear of the brush shaft.
3. Make sure that there is no abnormality in the brush.
4. Make sure that there is no play in the fit of the bearing and the housing.
5. Make sure that there is no play in the brush shaft.

Scraper

Inspection of Scraper

■ Inspection of Front Scraper

Note:

Depending on the specifications, this function may not be available.

The operating efficiency may be reduced due to frequent use, objects crushed during operation, or damage during transportation. Inspect the scraper, and replace any parts if necessary.

1. Make sure that there is no damage nor deformation of the scraper.
2. Make sure that there is no contact between the scraper and roller.

Handling Instructions

■ Inspection of Rear Scraper (Rod Type)

Note:

Depending on the specifications, this function may not be available.

The operating efficiency may be reduced due to frequent use, objects crushed during operation, or damage during transportation. Inspect the scraper, and replace any parts if necessary.

1. Make sure that there is no damage to or deformation of the scraper.
2. Make sure that there is no adhesion on the scraper mount.

■ Inspection of Rear Scraper (Wire Type)

Note:

Depending on the specifications, this function may not be available.

The operating efficiency may be reduced due to frequent use, objects crushed during operation, or damage during transportation. Inspect the scraper, and replace any parts if necessary.

1. Make sure that there are no breaks nor sagging in the scraper (wire).
2. Make sure that there is no contact between the scraper and roller.

Mower Unit

Cleaning of Mower Unit

Important

While cleaning, do not allow water on the sealed parts of the reel shaft. (Avoid high-pressure water cleaning.)

Otherwise, it may cause damage to the machine.

Be sure to clean the mower unit after use.

1. Stop the engine, and then remove the key.
2. Carefully clean the front and back of the mower unit with water or compressed air.
3. Remove any grass wrapped around the reel cutter (cutting cylinder).

Bolts and Nuts

Inspection of Bolts and Nuts

Important

A number of bolts are used in each part of this machine.

Be sure to re-tighten the bolts and nuts, because they may be loosened at the earlier stage of the use.

1. Check the bolts and nuts for looseness and coming off.
2. Check the bolts and nuts for cracks and damages.
3. Check the bolts and nuts for rust.
4. Check around the bolts and nuts for traces of rust fluid.
5. Check for unequal bolt length.
6. Check the bolts and nuts for stripped threads and abrasion.

Precautions for MaintenancePage 6-2**Greasing Page 6-2**

About GreasingPage 6-2

Greasing Points Page 6-2

Maintenance Work Page 6-5

Adjustment of Blade Engagement Page 6-5

Adjustment of Cutting Height Page 6-6

Adjustment of Cutter Adjustment
Spring Page 6-7Adjustment of Reel Cover (Variable
Type)Page 6-7

Adjustment of GroomerPage 6-8

Adjustment of Groomer Spring Page 6-9

Adjustment of CR Brush Page 6-10

Adjustment of Scraper Page 6-11

Adjustment of Belt TensionPage 6-12

Back Lapping Page 6-13

Sharpening of Reel Cutter (Cutting
Cylinder) Page 6-14Replacement of Reel Cutter (Cutting
Cylinder) Page 6-16Replacement of Bed Knife (Bottom
Blade) Page 6-17**Storage Page 6-17**

Long-Term Storage Page 6-17

Maintenance

Precautions for Maintenance

Warning

The chapter "Maintenance" in this manual describes practical measures which should be performed by a mechanic with expertise. The owner should instruct the mechanic with expertise to perform maintenance service for this machine.

Caution

First, learn well the operations you plan to perform.

Important

Use tools appropriate for each operation.

Important

Use Baronesse genuine parts for replacement and accessories. Our product warranty may be void if you use non-genuine parts for replacement or accessories.

Greasing

About Greasing

Since there may be adhesion or damage due to lack of grease on moving parts, they must be greased.

Add urea-based No. 2 grease in accordance with the Maintenance Schedule.

Other locations where the specified grease or lubricant is used are indicated in "Greasing Points".

Add grease using the specified grease or lubricant.

Greasing Points

Grease nipples are installed in the following locations.

Add grease to A every 10 hours, and B every 50 hours.

However, for locations where a time is specified, add grease according to that schedule.

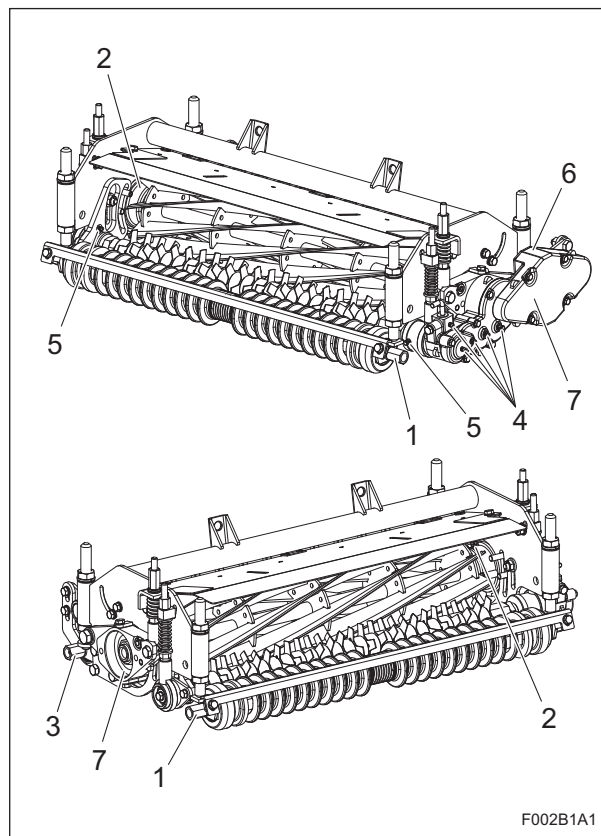

Greasing Points_001

	Location	No. of greasing points	Greasing period	
			A	B
1	Front roller shaft	2	-	B
2	Reel housing	2	-	B
3	Rear roller shaft	2	-	B
4	Groomer case	5	A	B
5	Groomer shaft	2	-	B
6	CR brush tension lever	1	-	B
7	Reel housing spindle bolt	2	See "Maintenance Schedule"	

1. Front roller shaft

There is one point each on the left and right of the front roller shaft.

Left end of front roller

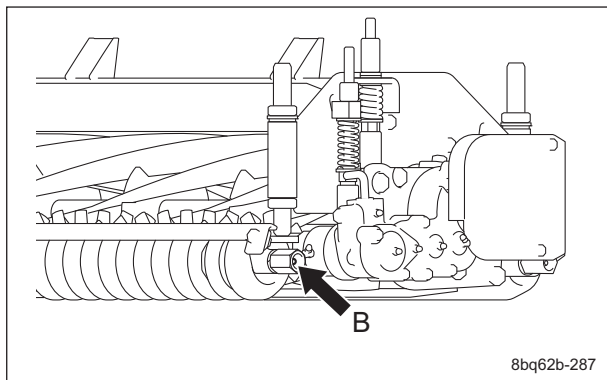

Greasing Points_002

Right end of front roller

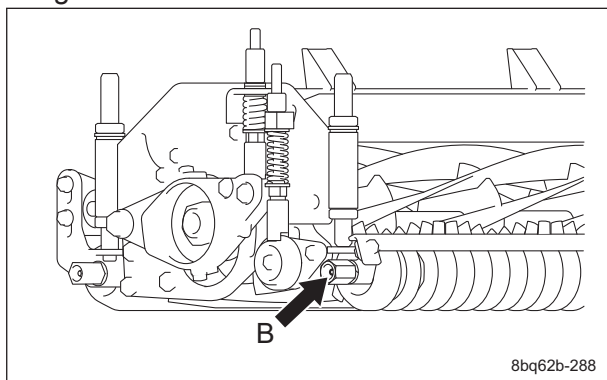

Greasing Points_003

2. Reel housing

There is one point each on the left and right of the reel housing.

Left reel housing

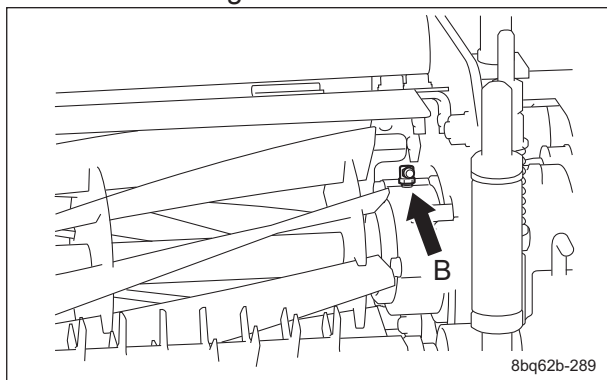

Greasing Points_004

Right reel housing

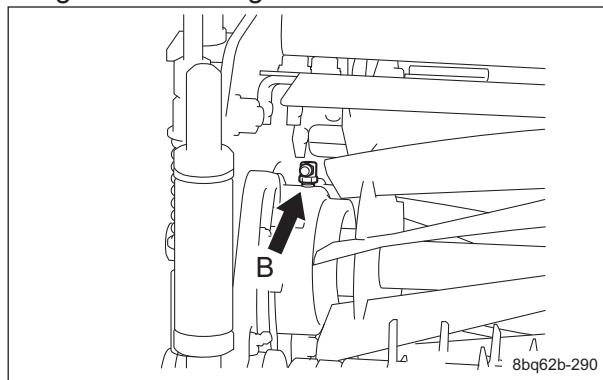

Greasing Points_005

3. Rear roller shaft

There is one point each on the left and right of the rear roller shaft.

Left end of rear roller

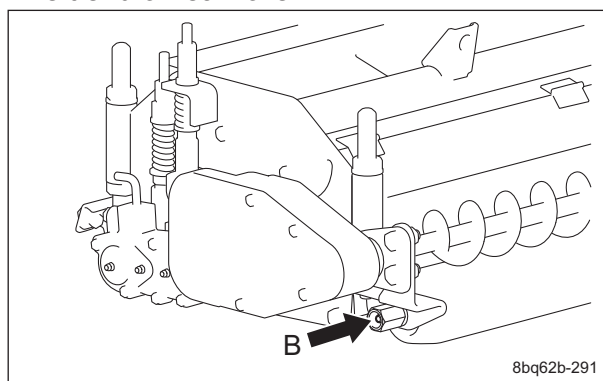

Greasing Points_006

Right end of rear roller

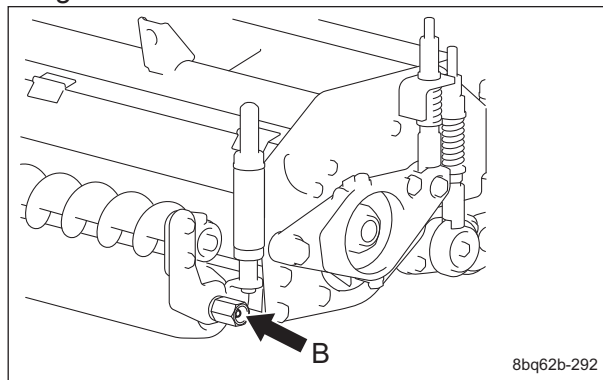

Greasing Points_007

Maintenance

4. Groomer case

Note:

Depending on the specifications, this function may not be available.

There are five points on the groomer case.

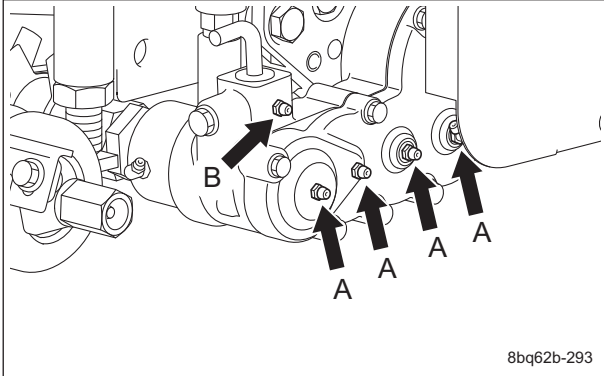

Greasing Points_008

5. Groomer shaft

Note:

Depending on the specifications, this function may not be available.

There is one point each on the left and right of the groomer shaft.

Groomer case side

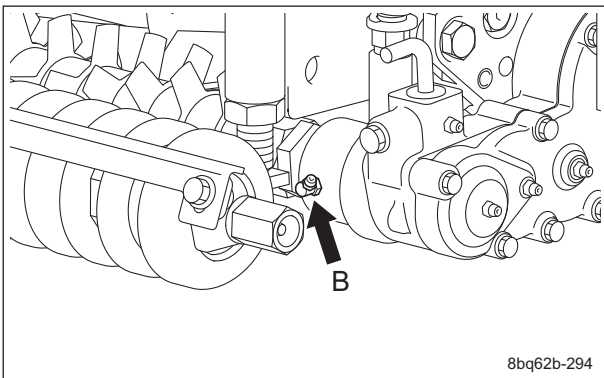

Greasing Points_009

Reel motor side

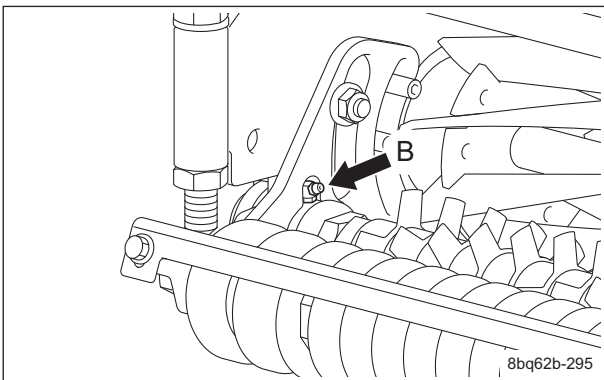

Greasing Points_010

6. CR brush tension lever

(Groomer + CR brush installation)

Note:

Depending on the specifications, this function may not be available.

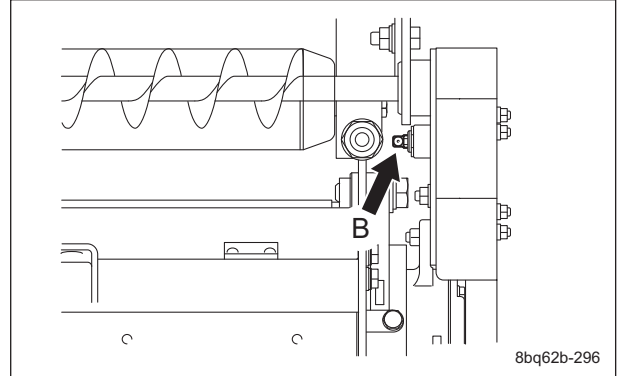

Greasing Points_011

7. Reel housing spindle bolt

There is one point each on the left and right of the mower unit.

Apply 0.5 g (0.001 lb) of grease to the reel housing spindle bolt according to the maintenance schedule.

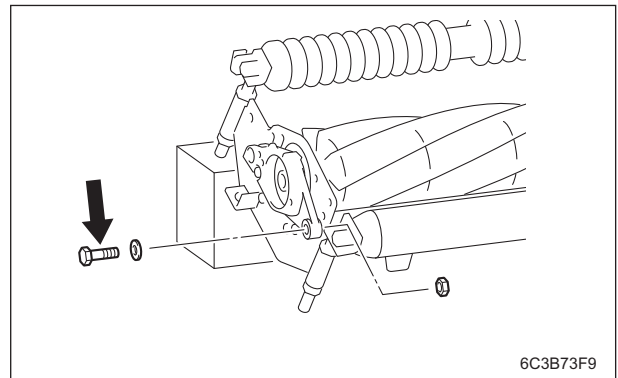

Greasing Points_012

Maintenance Work

Adjustment of Blade Engagement

Warning

Make sure that the parking brake is firmly applied before performing the operation.

Caution

Be sure to perform this operation on your own.

Caution

When handling the reel cutter (cutting cylinder) or bed knife (bottom blade), wear gloves to protect your hands. Pay attention not to let the reel cutter (cutting cylinder) catch your gloves. Otherwise, you may injure your hand or fingers.

Important

If the CR brush is installed (the mower unit equipped with only CR brush), loosen the left and right bolts and nuts used to install the CR brush before adjusting the blade engagement. After adjusting the blade engagement, adjust the CR brush, and then firmly tighten the loosened bolts and nuts.

1. Stop the engine.
2. Shift the reel rotation/stop switching lever to the "Stop" position.

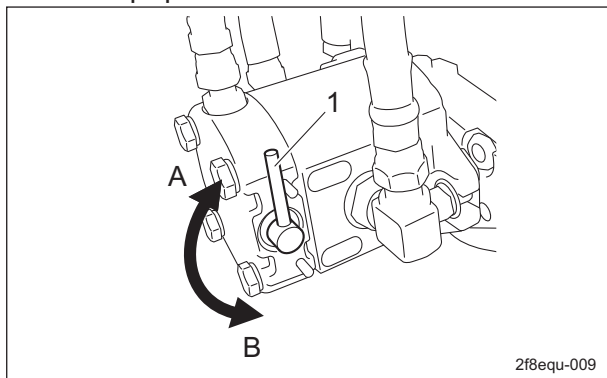

Adjustment of Blade Engagement_001

1	Reel rotation/stop switching lever
A	Rotation
B	Stop

3. With the cutter adjustment nut, adjust the engagement between the reel cutter (cutting cylinder) and the bed knife (bottom blade) so that newspaper (two to three sheets) will be cut by the edge of both blades when the blades in their entirety come slightly into contact with each other.
4. Insert two or three strips of newspaper into the space between the reel cutter (cutting cylinder) and the bed knife (bottom blade) at an angle of 90 degrees. Then, rotate the reel cutter (cutting cylinder) counter-clockwise (when you face the mower unit from the left) by hand to check the sharpness of the blades.
Check the sharpness of the entire range (at three or four points) of the reel cutter (cutting cylinder).

- If there is a gap between the blade edges: Loosen the cutter adjustment nut to apply more contact pressure between the reel cutter (cutting cylinder) and the bed knife (bottom blade).
- If the reel cutter (cutting cylinder) is too tight to turn: Tighten the cutter adjustment nut to reduce the contact pressure between the reel cutter (cutting cylinder) and the bed knife (bottom blade).
- If the blades still cannot cut well: Perform back lapping of the reel cutter (cutting cylinder) and the bed knife (bottom blade).

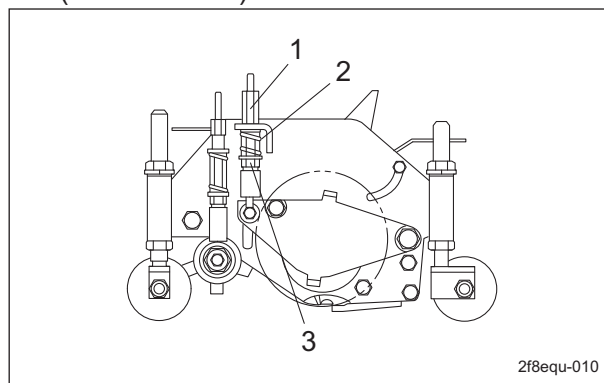

Adjustment of Blade Engagement_002

1	Cutter adjustment nut
2	Spring
3	Pipe with cutter adjustment screw

Maintenance

Adjustment of Cutting Height

Cutting Height Adjustment

⚠ Caution

Do not perform the operation with any other persons.

Adjust the cutting height to fit your cutting work.

1. Set the enclosed cutting height gauge.

[1] Set the small screw for cutting height setup to the cutting height.

[2] Set the angle of the bed knife (bottom blade) with the small screw for bed knife angle setup.

"Bed Knife (Bottom Blade) Angle Table" (Page 6-7)

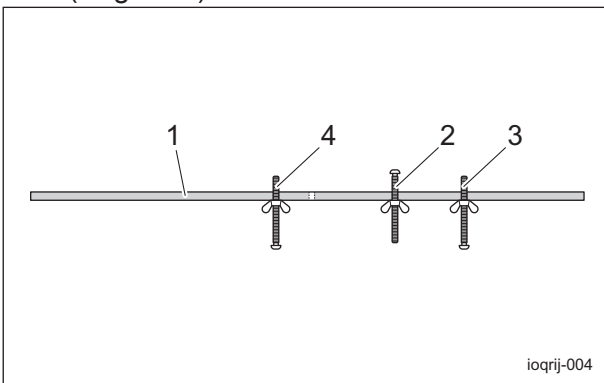

Cutting Height Adjustment_001

1	Cutting height gauge
2	Small screw for cutting height setup
3	Small screw for bed knife angle setup
4	Small screw for groomer setup

2. Position the small screw for cutting height setup set on the cutting height gauge as well as the small screw for bed knife angle setup against the bed knife (bottom blade), and then adjust the rear roller.

[1] Adjust the left and right ends of the bed knife (bottom blade) until it is level, and then determine the position of the rear roller based on the angle of the bed knife (bottom blade).

[2] Loosen the cutting height adjustment nuts, and then adjust the rear roller so that it comes into contact with the cutting height gauge.

Since the rear roller cannot be accurately adjusted if the front roller is in contact with the cutting height gauge, raise the front roller so it is not in contact with the cutting height gauge.

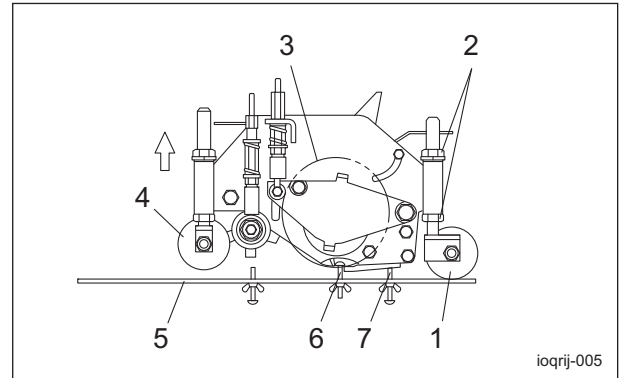

Cutting Height Adjustment_002

1	Rear roller
2	Cutting height adjustment nut
3	Reel cutter (cutting cylinder)
4	Front roller
5	Cutting height gauge
6	Small screw for cutting height setup
7	Small screw for bed knife angle setup

3. After making adjustments, firmly tighten the cutting height adjustment nuts.

4. Loosen the cutting height adjustment nuts, and then adjust the front roller so that it comes into contact with the cutting height gauge.

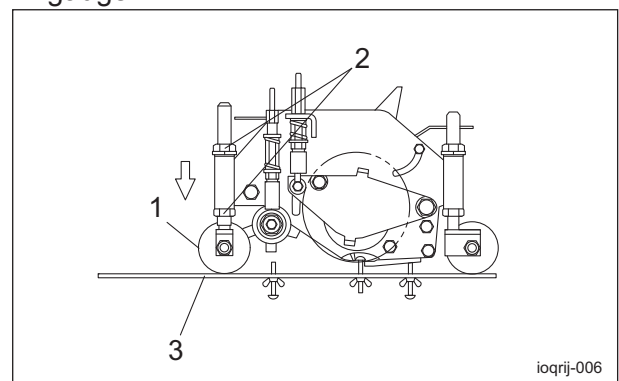

Cutting Height Adjustment_003

1	Front roller
2	Cutting height adjustment nut
3	Cutting height gauge

- After making adjustments, firmly tighten the cutting height adjustment nuts.

Bed Knife (Bottom Blade) Angle Table

Make adjustments according to the conditions based on a bed knife (bottom blade) angle of 5°.

<Example>

For a bed knife (bottom blade) angle of 5° at a cutting height of 15.0 mm (0.59 in), set the height of the bottom of the bed knife (bottom blade) to 12.0 mm (0.47 in).

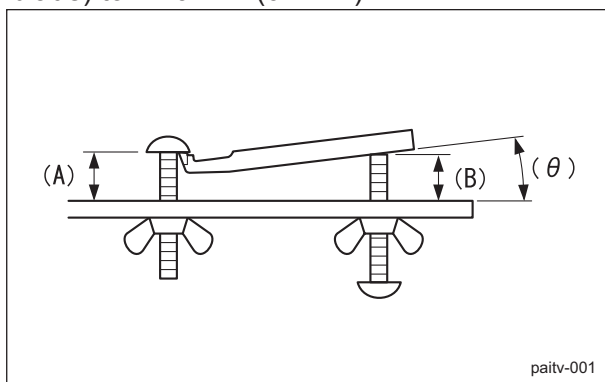

Bed Knife (Bottom Blade) Angle Table_001

A	Cutting height
B	Height of bottom of bed knife (bottom blade)
θ	Bed knife (bottom blade) angle

Bed knife (bottom blade) angle (θ)	Value of (B)
7°	Cutting height (A)-0.6 mm (-0.02 in)
6°	Cutting height (A)-1.8 mm (-0.07 in)
5°	Cutting height (A)-3.0 mm (-0.12 in)
4°	Cutting height (A)-4.2 mm (-0.17 in)
3°	Cutting height (A)-5.4 mm (-0.21 in)
2°	Cutting height (A)-6.6 mm (-0.26 in)
1°	Cutting height (A)-7.8 mm (-0.31 in)

Adjustment of Cutter Adjustment Spring

If the diameter of the reel cutter (cutting cylinder) becomes smaller, adjust the cutter adjustment spring.

- Adjust the blade engagement.

- Loosen the pipe with cutter adjustment screw and adjust it so that the length of the spring coil is approximately 27.0 mm (1.06 in).

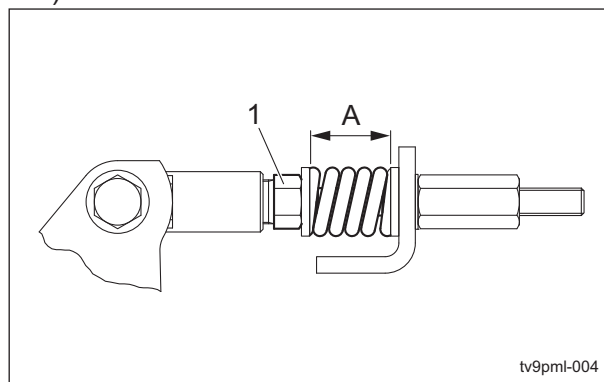

Adjustment of Cutter Adjustment Spring_001

1	Pipe with cutter adjustment screw
A	27.0 mm (1.06 in)

Adjustment of Reel Cover (Variable Type)

The angle of the reel cover can be adjusted. Loosen the left and right bolts securing the reel cover, and then adjust the angle of the cover. If the grass catcher is installed, position the reel cover as follows.

- Front collection: Close the reel cover.
- Rear collection: Open the reel cover.

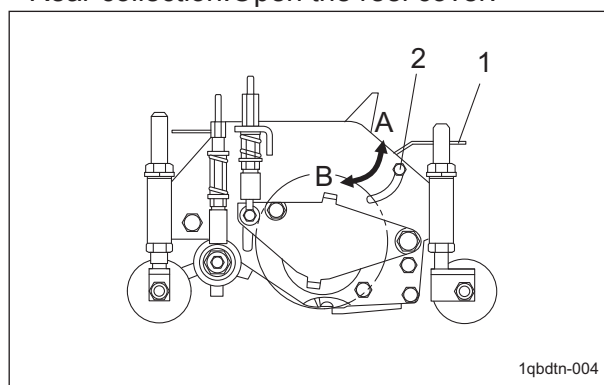

Adjustment of Reel Cover (Variable Type)_001

1	Reel cover
2	Lock bolt
A	Open
B	Close

Maintenance

Adjustment of Groomer

Note:

Depending on the specifications, this function may not be available.

Important

Adjust the groomer height so that it is the same level on the right and left sides.

Important

Set the groomer height more than 5.0 mm (0.2 in) from the ground. If it is set lower, the groomer shaft, bearings, gears, etc., will be damaged.

Adjust the groomer height according to the grooming work.

Note:

While the groomer is not used, raise the groomer height.

1. Set the small screw for groomer setup of the cutting height gauge to the desired height.

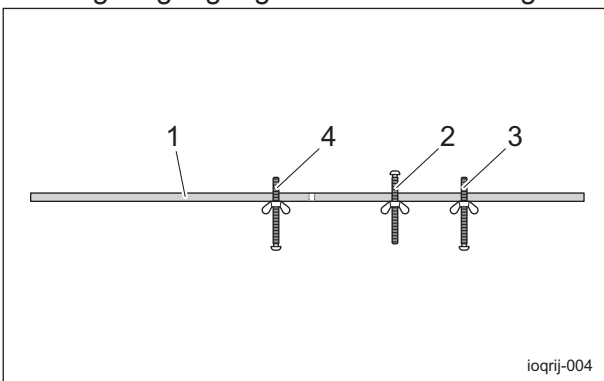

Adjustment of Groomer_001

1	Cutting height gauge
2	Small screw for cutting height setup
3	Small screw for bed knife angle setup
4	Small screw for groomer setup

2. Loosen the nuts securing the right and left rod holders.

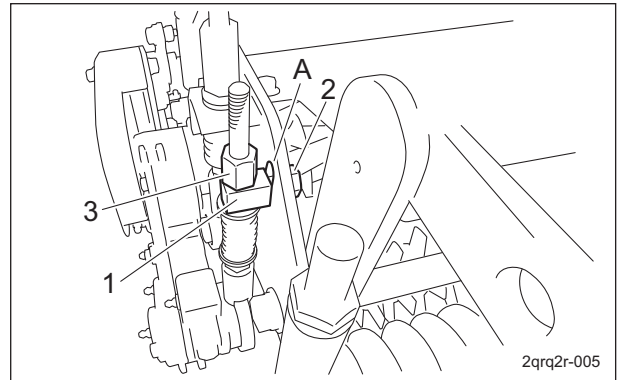

Adjustment of Groomer_002

1	Rod holder
2	Nut
3	Groomer adjustment nut
A	Long hole

3. Lower the right and left rod holders to the bottoms of the long holes.
4. Tighten the nuts to firmly secure the right and left rod holders.
5. Position the front and rear rollers against the cutting height gauge at the right and left ends of the mower unit.

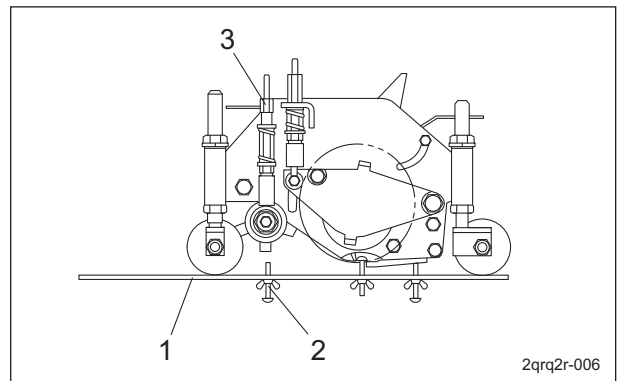

Adjustment of Groomer_003

1	Cutting height gauge
2	Small screw for groomer setup
3	Groomer adjustment nut

Important

Adjust the position so that the vertical blade can make contact with the small screw for groomer setup.

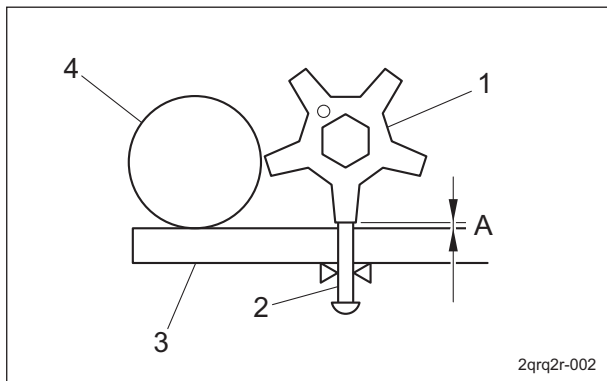

Adjustment of Groomer_004

1	Vertical blade
2	Small screw for groomer setup
3	Cutting height gauge
4	Front roller
A	Groomer height

- Loosen the pipe with adjustment screw and adjust it so that the length of the groomer spring is approximately 45.0 mm (1.77 in).

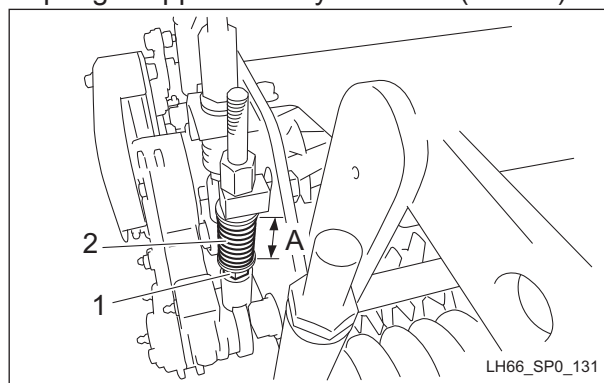

Adjustment of Groomer Spring_001

1	Pipe with adjustment screw
2	Groomer spring
A	45.0 mm (1.77 in)

- Adjust the groomer height with the groomer adjustment nut.
- Follow the same steps to adjust the groomer height on the opposite side.
- Bring the cutting height gauge into contact with the front and rear rollers at the left and right ends of the mower unit again, and check that the groomer is at the desired height.

Adjustment of Groomer Spring

Note:

Depending on the specifications, this function may not be available.

- Adjust the height of groomer.

Maintenance

Adjustment of CR Brush

Adjustment of CR Brush (CR Brush Only Installation)

Note:
Depending on the specifications, this function may not be available.

Important

Do not place the brush in contact with the rear roller too tightly. It will cause belt slip and break.

Important

The rotating CR brush prevents grass clippings, etc., from attaching to the rear roller.

1. Loosen the left and right bolts and nuts used to install the CR brush.
2. Adjust the CR brush so that there is a clearance of 0 to 1.0 mm (0 to 0.039 in) between it and the rear roller, and then firmly tighten the loosened bolts and nuts.

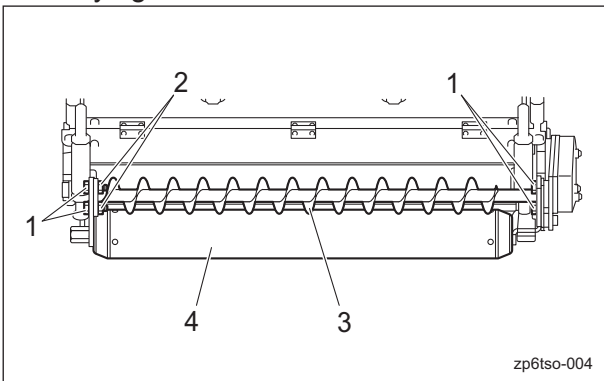

Adjustment of CR Brush (CR Brush Only Installation)_001

1	Bolt
2	Nut
3	Brush
4	Rear roller

Adjustment of CR Brush (installed together with Groomer)

Note:
Depending on the specifications, this function may not be available.

Important

Do not place the brush in contact with the rear roller too tightly. It will cause belt slip and break.

Important

The rotating CR brush prevents grass clippings, etc., from attaching to the rear roller.

1. Loosen the left and right bolts and nuts used to install the CR brush.
2. Adjust the CR brush so that there is a clearance of 0 to 1.0 mm (0 to 0.039 in) between it and the rear roller, and then firmly tighten the loosened bolts and nuts.

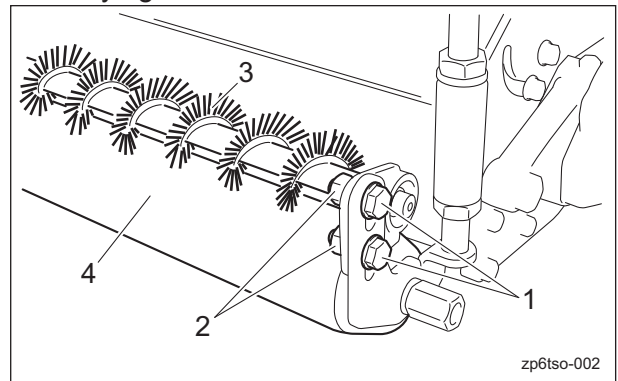

Adjustment of CR Brush (installed together with Groomer)_001

1	Bolt
2	Nut
3	Brush
4	Rear roller

Adjustment of Scraper

Adjustment of Front Scraper

Note:
Depending on the specifications, this function may not be available.

Important

Do not place the scraper in contact with the front roller too tightly. It will cause deformation of the scraper and damage of the front roller.

The scraper prevents grass clippings, etc., from attaching to the front roller.

1. Loosen the left and right bolts and nuts of the scraper.

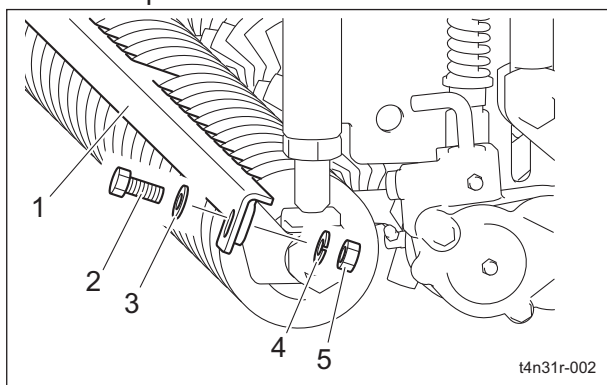

Adjustment of Front Scraper_001

1	Scraper
2	Bolt
3	Washer
4	Spring washer
5	Nut

2. Adjust the scraper so that there is a clearance of 2.0 to 3.0 mm (0.079 to 0.118 in) between it and the outer diameter surface of the front roller, and then firmly tighten the loosened bolts and nuts.

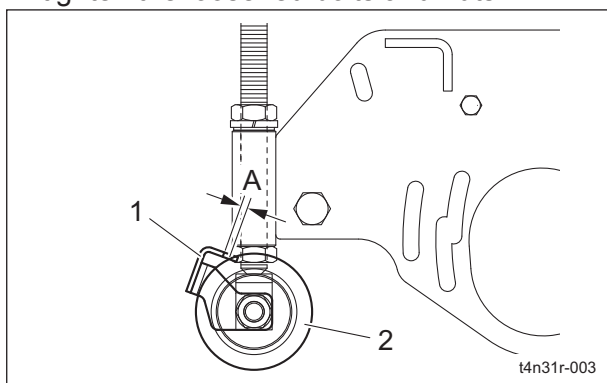

Adjustment of Front Scraper_002

1	Scraper
2	Front roller
A	2.0 - 3.0 mm (0.079 - 0.118 in)

Adjustment of Rear Scraper (Wire Type)

Note:
Depending on the specifications, this function may not be available.

Important

Do not place the scraper in contact with the rear roller too tightly. It will cause the scraper break and slack.

The scraper prevents grass clippings, etc., from attaching to the rear roller.

1. Loosen the left and right lock nuts and nuts of the scraper.
2. Adjust the scraper so that there is a clearance of 2.0 to 3.0 mm (0.079 to 0.118 in) between it and the rear roller, and then secure it with the lock nuts.

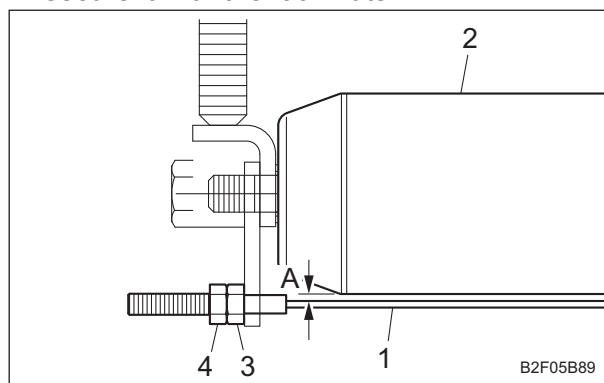

Adjustment of Rear Scraper (Wire Type)_001

1	Scraper
2	Rear roller
3	Nut
4	Lock nut
A	2.0 - 3.0 mm (0.079 - 0.118 in)

Maintenance

Adjustment of Belt Tension

1	Tension pulley adjustment bolt
2	Belt

Warning

Be sure to stop the engine before adjusting the belts.

Warning

If you have removed covers, etc., be sure to securely install them in their original positions. If covers, etc., remain removed, the operator may come in contact with rotating parts or belts, or foreign objects may fly off, possibly resulting in injuries.

Important

For the specified value of belt tension, refer to Adjusted Values.
Check belt tension after rotating the belt several times.

If the belt becomes slack due to frequent use, it may jump or slip.

In addition, if it is overtightened, it may wear prematurely.

If necessary, adjust it, and always check the belt for appropriate tension.

CR Brush Drive Belt (Installation with only CR Brush)

Note:

Depending on the specifications, this function may not be available.

1. Remove the belt cover.
2. Check the belt tension.
3. If the belt tension is inappropriate, adjust the belt tension with the tension pulley adjustment bolt.

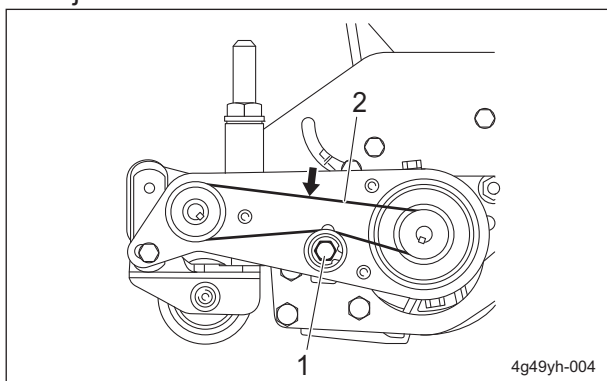

CR Brush Drive Belt (Installation with only CR Brush)_001

The belt tension is appropriate when the belt slacks by approximately 5.0 to 6.0 mm (0.197 to 0.236 in) when you apply a force of 10.0 N (1.0 kgf) with your finger to the belt at the middle point between the pulleys.

CR Brush Drive Belt (with Groomer installed together)

Note:

Depending on the specifications, this function may not be available.

No need to adjust this belt.

Back Lapping

Back lapping is work similar to sharpening a cooking knife. If the edges of the reel cutter (cutting cylinder) and the bed knife (bottom blade) become blunt and make cutting difficult, both the reel cutter (cutting cylinder) and the bed knife (bottom blade) should be simultaneously sharpened by reversing the reel cutter (cutting cylinder) with an abrasive paste applied.

However, back lapping is a temporary measure and would not restore the sharpness completely.

If the edges of the reel cutter (cutting cylinder) and the bed knife (bottom blade) become blunt and make cutting difficult, perform back lapping in the following procedure.

Warning

The reel cutter rotates during back lapping work. Keep hands and feet away from moving parts.

Caution

Be careful not to inhale exhaust gas during back lapping.

Caution

Do not perform back lapping work with any other persons.

1. Prepare newspaper cut into strip, abrasive with back lapping powder mixed with oil or gel compound (Baroness genuine abrasive), and a brush.

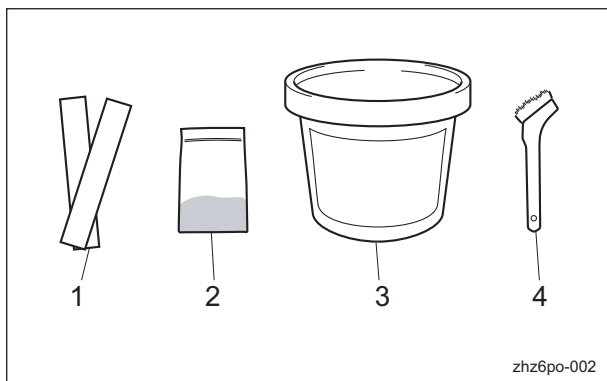

Back Lapping_001

1	Newspaper
2	Back lapping powder
3	Gel compound
4	Brush

Note:

The mixture ratio of the abrasive is 1 part back lapping powder (#150 - #200) : 3-4 parts oil.

Caution

When handling the reel cutter or bed knife, wear gloves to protect your hands. Pay attention not to let the reel cutter catch your gloves, etc. Otherwise, your hand or fingers may be injured.

Important

Check sharpness with the blade engagement condition after cutting.

2. Raise all mower units.
3. Stop the engine, and then apply the parking brake.
4. Set the reel rotation/stop switching lever to the "Stop" position.

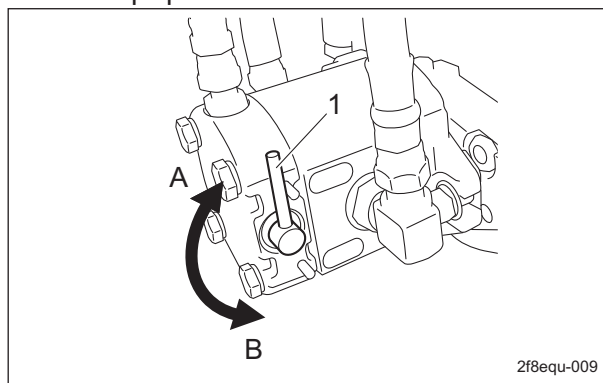

2f8equ-009

Back Lapping_002

1	Reel rotation/stop switching lever
A	Rotate
B	Stop

5. Insert two or three strips of newspaper into the space between the reel cutter and the bed knife at an angle of 90 degrees. Then, rotate the reel cutter counterclockwise (as seen from the left side of the mower unit) by hand to check the sharpness.
6. Check the sharpness along the entire reel cutter surface (around 3 to 4 positions).

Maintenance

7. Check the sharpness and mark areas that are sharp with chalk or similar.
8. Set the reel rotation/stop switching lever of the hydraulic motors for the mower units that require back lapping to the "Rotation" position.
For mower units that do not require back lapping, set the lever to the "Stop" position.
9. Start the engine.
Note:
The engine will not start if the reel is set to rotate on the main vehicle side.
10. Lower all mower units to the ground.
11. Set the reel rotation to "Back lapping rotation (reverse)."
12. Run the engine at low speed.
13. Rotate the reel cutter for back lapping.
14. Adjust the rotation speed of the reel cutter with the reel rotation/stop switching lever.
15. Apply abrasive to a brush, and apply evenly to areas of the reel cutter that are sharp using the chalk markings as a guide. (Never apply it to areas that have poor sharpness.)
16. Keep the engine rotating for a while until there is no contact noise, and then stop the rotation of the reel cutter.
17. Raise all mower units.
18. Stop the engine.
19. Wash off the abrasive applied to the reel cutter or wipe it clean with waste cloth or similar, and check the sharpness.
20. Repeat the procedures from 4 through 19 for back lapping until the entire reel cutter surface (around 3 to 4 positions) is even.
21. Lower all mower units to the ground.
22. Next, apply abrasive across the entire reel cutter blade edge for final back lapping.
23. Stop the reel rotation.
24. Stop the engine.
25. Carefully wash off all the remaining abrasive completely.
26. Set the reel rotation to "Mowing rotation (normal)."
27. Return the reel rotation/stop switching lever to the "Stop" position.
28. Adjust the blade engagement while checking the sharpness.

Sharpening of Reel Cutter (Cutting Cylinder)

The sharpening of the reel cutter (cutting cylinder) consists in maintaining its roundness and creating a relief (second edge face). This work should be performed if the sharpness cannot be restored, even after back lapping, or if the relief (second edge face) has worn away.

Sharpen the reel cutter (cutting cylinder) when the sharpness cannot be restored, even after back lapping, or when the relief (second edge face) has worn away, there is full contact or back lapping takes too much time.

In addition, if the reel cutter (cutting cylinder) becomes worn and its shape conical, perform cylindrical grinding to return it to a cylindrical shape.

For sharpening the reel cutter (cutting cylinder), contact your dealer or Baroness unless you have a grinding machine.

Caution

Both the reel cutter (cutting cylinder) and the bed knife (bottom blade) are edged tools. Handle them carefully, since they could cut your hands and feet.

Caution

Wear gloves when touching edged tools to avoid cutting your hands.

The criteria for sharpening the reel cutter (cutting cylinder) are described below. However, these criteria are only a reference and do not guarantee performance of a reel cutter (cutting cylinder).

1. If the outer diameter of the reel cutter (cutting cylinder) after sharpening is more than the usage limit, the reel cutter (cutting cylinder) can be sharpened.

New		Usage limit	
Dimension A (Outer diameter of reel cutter (cutting cylinder))	Dimension B (Distance from blade edge to outer edge of reel cutter (cutting cylinder) shaft)	Dimension A (Outer diameter of reel cutter (cutting cylinder))	Dimension B (Distance from blade edge to outer edge of reel cutter (cutting cylinder) shaft)
163 mm (6.42 in)	68.8 mm (2.71 in)	143 mm (5.63 in)	58.8 mm (2.31 in)

Note:
The outer diameter of the reel cutter (cutting cylinder) shaft is 25.4 mm (1.00 in).

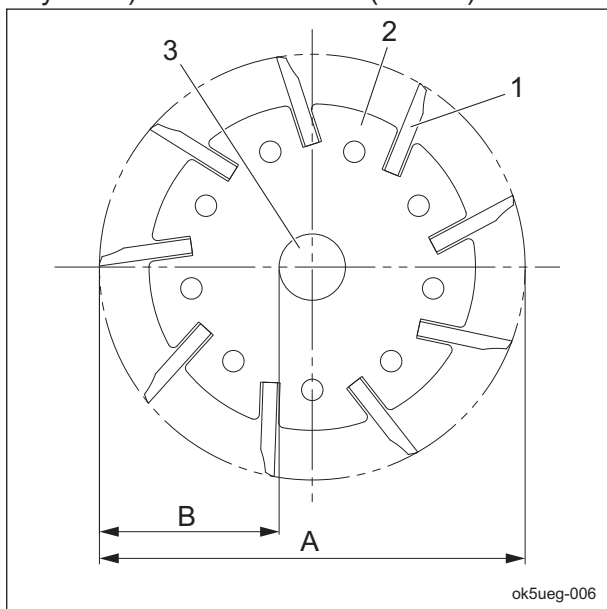

Sharpening of Reel Cutter (Cutting Cylinder)_001

1	Reel cutter (cutting cylinder) blade
2	Reel cutter (cutting cylinder) disc
3	Reel cutter (cutting cylinder) shaft
A	Outer diameter of reel cutter (cutting cylinder)
B	Distance from blade edge to outer edge of reel cutter (cutting cylinder) shaft

2. Sharpening is necessary when the reel cutter (cutting cylinder) reaches a condition described below.

[1] When the sharpening width (length of contacting surface of bed knife (bottom blade)) for the outer diameter of the reel cutter (cutting cylinder) is greater than the usage limit.

Outer diameter of reel cutter (cutting cylinder) (new part)	Usage limit of sharpening width for outer diameter of reel cutter (cutting cylinder)
163 mm (6.42 in)	3.0 mm (0.12 in) (factory-recommended)

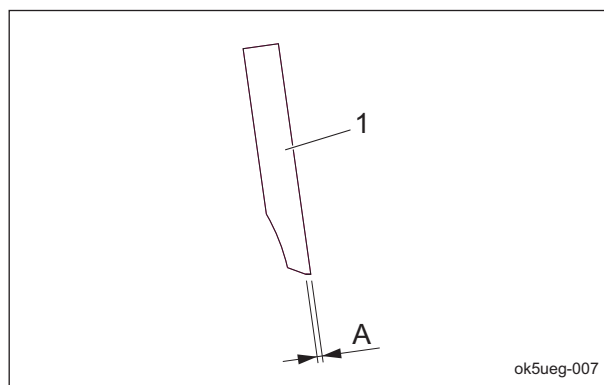

Sharpening of Reel Cutter (Cutting Cylinder)_002

1	Reel cutter (cutting cylinder) blade
A	Sharpening width for outer diameter of reel cutter (cutting cylinder)

[2] When the edges become blunt or the blade edge cannot be formed with back lapping

[3] When the reel cutter (cutting cylinder) becomes worn and its shape conical, or when blade engagement adjustment cannot be performed

Maintenance

Replacement of Reel Cutter (Cutting Cylinder)

⚠ Caution

Both the reel cutter (cutting cylinder) and the bed knife (bottom blade) are edged tools. Handle them carefully, since they could cut your hands and feet.

⚠ Caution

Wear gloves when touching edged tools to avoid cutting your hands.

The criteria for replacing the reel cutter (cutting cylinder) are described below.

However, these criteria are only a reference and do not guarantee performance like that of a new reel cutter (cutting cylinder).

1. When the outer diameter of the reel cutter (cutting cylinder) is less than the usage limit

New		Usage limit	
Dimension A (Outer diameter of reel cutter (cutting cylinder))	Dimension B (Distance from blade edge to outer edge of reel cutter (cutting cylinder) shaft)	Dimension A (Outer diameter of reel cutter (cutting cylinder))	Dimension B (Distance from blade edge to outer edge of reel cutter (cutting cylinder) shaft)
163 mm (6.42 in)	68.8 mm (2.71 in)	143 mm (5.63 in)	58.8 mm (2.31 in)

Note:

The outer diameter of the reel cutter (cutting cylinder) shaft is 25.4 mm (1.00 in).

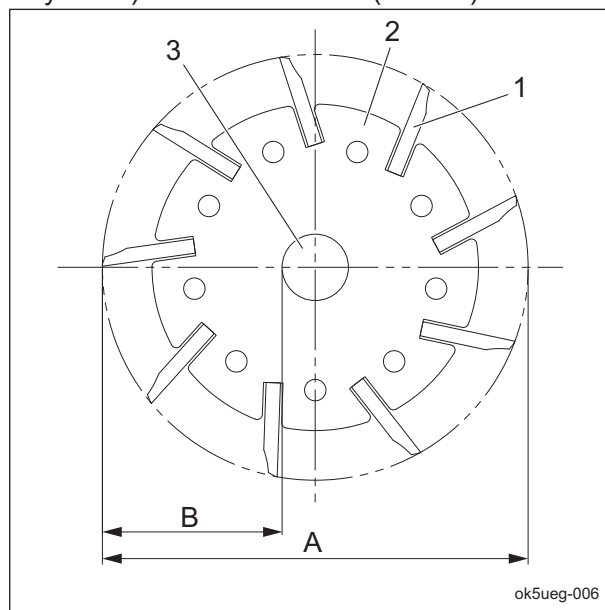

Replacement of Reel Cutter (Cutting Cylinder)_001

1	Reel cutter (cutting cylinder) blade
2	Reel cutter (cutting cylinder) disc
3	Reel cutter (cutting cylinder) shaft
A	Outer diameter of reel cutter (cutting cylinder)
B	Distance from blade edge to outer edge of reel cutter (cutting cylinder) shaft

Replacement of Bed Knife (Bottom Blade)

⚠ Caution

Both the reel cutter (cutting cylinder) and the bed knife (bottom blade) are edged tools. Handle them carefully, since they could cut your hands and feet.

⚠ Caution

Wear gloves when touching edged tools to avoid cutting your hands.

The criteria for replacing the bed knife (bottom blade) are described below.

1. When the reel cutter (cutting cylinder) is ground
 2. When the reel cutter (cutting cylinder) is replaced
 3. When the bed knife (bottom blade) is worn
High-speed-steel-tipped blade
- Replace the bed knife (bottom blade) before it no longer has a tip.

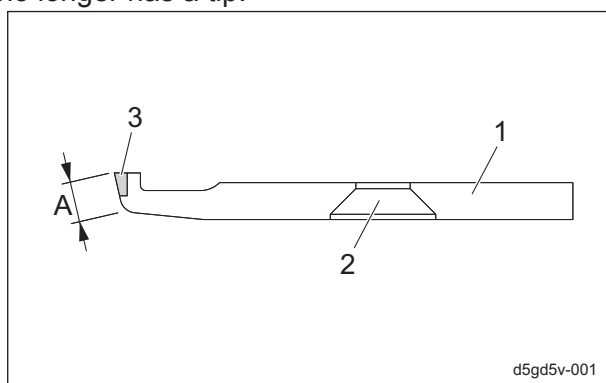

Replacement of Bed Knife (Bottom Blade)_001

1	Bed knife (bottom blade)
2	Mounting hole
3	Tip
A	Front face

Storage

Long-Term Storage

Follow the instructions below for long-term storage of the machine.

1. Cleaning
 - Remove dirt, grass clippings, oil stains etc. completely.
2. Oil filling
 - Grease and lubricate the appropriate points.

3. Storage location

- Cover the machine and store it in a dry place where it will not be exposed to rain.

Maintenance

Appended Table

Tightening Torques Page 7-2

Standard Tightening Torques Page 7-2

Principal Tightening Torques Page 7-4

Maintenance Schedule Page 7-5

List of Adjusted Values Page 7-6

Appended Table

Tightening Torques

Important

Refer to the Tightening Torque table.
Note that the Baroness product warranty may not apply to defects caused by incorrect or overtorque tightening, etc.

Standard Tightening Torques

Bolts and Nuts

Important

A number of bolts are used in each part of this machine.
Be sure to re-tighten the bolts and nuts, because they may be loosened at the earlier stage of the use.

As to the bolts and nuts without any special instruction, tighten them in appropriate tightening torque with proper tool.

Too much tightening may cause the looseness or damage of the screw.

The strength of tightening is determined by types of screws, strength, the friction of thread face or base face and others.

The table below is for the galvanized or parkerized bolts.

In case that the strength of internal thread is weak, it is not applied.

Do not use rusty or sand attached "screw."

Otherwise, it may cause insufficient tightening even if you apply the specified tightening torque.

The friction of the screw face becomes higher and the tightening torque is canceled out by the friction, therefore sufficient tightening cannot be applied.

If "screw" is wet by water or oil, do not tighten it with normal tightening torque.

If the screw is wet, the torque coefficient will get smaller and it may result in too much tightening.

Too much tightening may cause looseness by the screw stretched or result in damage.



Do not use a bolt experienced too much burden.

Using the impact wrench requires the skill.

Do exercise as much as possible for steady tightening.

Appended Table

Nominal diameter	General bolt		
	Strength classification 4.8		
	 tib3yb-001		
	N-m	kgf-cm	lb-in
M5	3 - 5	30.59 - 50.99	26.55 - 44.26
M6	7 - 9	71.38 - 91.77	61.96 - 79.66
M8	14 - 19	142.76 - 193.74	123.91 - 168.17
M10	29 - 38	295.71 - 387.49	256.68 - 336.34
M12	52 - 67	530.24 - 683.20	460.25 - 593.02
M14	70 - 94	713.79 - 958.52	619.57 - 831.99
M16	88 - 112	897.34 - 1142.06	778.89 - 991.31
M18	116 - 144	1,182.85 - 1,468.37	1,026.72 - 1,274.54
M20	147 - 183	1,498.96 - 1,866.05	1,301.10 - 1,619.73
M22	295	3,008.12	2,611.05
M24	370	3,772.89	3,274.87
M27	550	5,608.35	4,868.05
M30	740	7,545.78	6,549.74

Nominal diameter	Heat-treated bolt					
	Strength classification 8.8			Strength classification 10.9		
	 tib3yb-002			 tib3yb-003		
	N-m	kgf-cm	lb-in	N-m	kgf-cm	lb-in
M5	5 - 7	50.99 - 71.38	44.26 - 61.96	7 - 10	71.38 - 101.97	61.96 - 88.51
M6	8 - 11	81.58 - 112.17	70.81 - 97.36	14 - 18	142.76 - 183.55	123.91 - 159.32
M8	23 - 29	234.53 - 295.71	203.57 - 256.68	28 - 38	285.52 - 387.49	247.83 - 336.34
M10	45 - 57	458.87 - 581.23	398.30 - 504.51	58 - 76	591.43 - 774.97	513.36 - 672.68
M12	67 - 85	683.20 - 866.75	593.02 - 752.34	104 - 134	1,060.49 - 1,366.40	920.50 - 1186.03
M14	106 - 134	1,080.88 - 1,366.40	938.21 - 1,186.03	140 - 188	1,427.58 - 1,917.04	1,239.14 - 1,663.99
M16	152 - 188	1,549.94 - 1,917.04	1,345.35 - 1,663.99	210 - 260	2,141.37 - 2,651.22	1,858.71 - 2,301.26
M18	200 - 240	2,039.40 - 2,447.28	1,770.20 - 2,124.24	280 - 340	2,855.16 - 3,466.98	2,478.28 - 3,009.34
M20	245 - 295	2,498.27 - 3,008.12	2,168.50 - 2,611.05	370 - 450	3,772.89 - 4,588.65	3,274.87 - 3,982.95
M22	-	-	-	530	5,404.41	4,691.03
M24	-	-	-	670	6,831.99	5,930.17
M27	-	-	-	1,000	10,197.00	8,851.00
M30	-	-	-	1,340	14,628.78	11,860.34

Note:

The same values are applied to "fine screw thread."

Appended Table

Principal Tightening Torques

Tightening Torque by Model

LH66/LH62

Tighten the following bolts and nuts at the torque specified in the table.

For thread locking adhesive, apply a middle strength thread locker (ThreeBond 1322 or equivalent anaerobic sealant).

Location	Code	Part name	Tightening torque			Thread locking adhesive
			N-m	kgf-cm	lb-in	
Bed knife	K0071001182	SCREW, HT FLAT HEAD M10-16	29 - 38	295.71 - 387.49	256.68 - 336.34	-
Housing B	K0028080200	SETSCREW, SUS M8-20	3	30.59	26.55	-

Appended Table

Maintenance Schedule

LH62 • LH66

Follow the maintenance schedule below.

● • • • Inspect, adjust, supply, clean (first time)

○ • • • Inspect, adjust, supply, clean

▲ • • • Replace (first time)

△ • • • Replace

Maintenance Item	Before Work	After Work	Every 10 hrs.	Every 50 hrs.	Every 250 hrs.	Every 500 hrs.	Every year	When Required	Remarks
Check blade (Reel cutter and Bed knife)	○								
Check cover	○								
Check roller	○								
Check groomer	○								
Check CR brush	○								
Check scraper	○								
Check belt	○								
Check damaged parts	○								
Check tightening bolts and nuts	○								
Engage blades	○								
Check mowing height	○								
Adjust reel cover (Variable type)	○								
Adjust groomer	○								
Adjust CR brush	○								
Adjust scraper	○								
Clean mower unit		○							
Backlap blades								○	
Grease			○	○					Maintenance schedules differ according to greasing points
Clean inside of CR brush belt cover				○					
Grease spindle bolt of reel housing						○	○		Every 500 hours or every year whichever comes earlier, and when replacing a reel cutter additionally.
Adjust cutter adjustment spring								○	
Adjust belt tension of CR brush								○	
Regrind blades (Reel cutter)								○	Grind/Replace blades as and when required

• The values for consumables are not guaranteed.

Appended Table

List of Adjusted Values

Cutter adjustment spring		27.0 mm (1.06 in)	Length of spring coil
Groomer spring		45.0 mm (1.77 in)	Length of spring coil
CR brush	With CR brush	0 - 1.0 mm (0 - 0.039 in)	Gap between brush and rear roller
	With CR brush and groomer		
Front scraper		2.0 - 3.0 mm (0.079 - 0.118 in)	Gap between scraper and outer diameter surface of roller
Rear scraper		2.0 - 3.0 mm (0.079 - 0.118 in)	Gap between scraper and roller
CR brush drive belt	With CR brush	5.0 - 6.0 mm (0.197 - 0.236 in)	Slack when belt pressed with 10.0 N (1.0 kgf) at the middle point between pulleys

BARONESS[®]
Quality on Demand

 **KYOEISHA CO., LTD.**
Head Office 1-26, Miyuki-cho, Toyokawa-city, Tel :+81-533-84-1390
Aichi-pref, 442-8530 JAPAN Fax:+81-533-84-1220