

LM3210A

5-Unit Reel Mower

Owner's Operating Manual

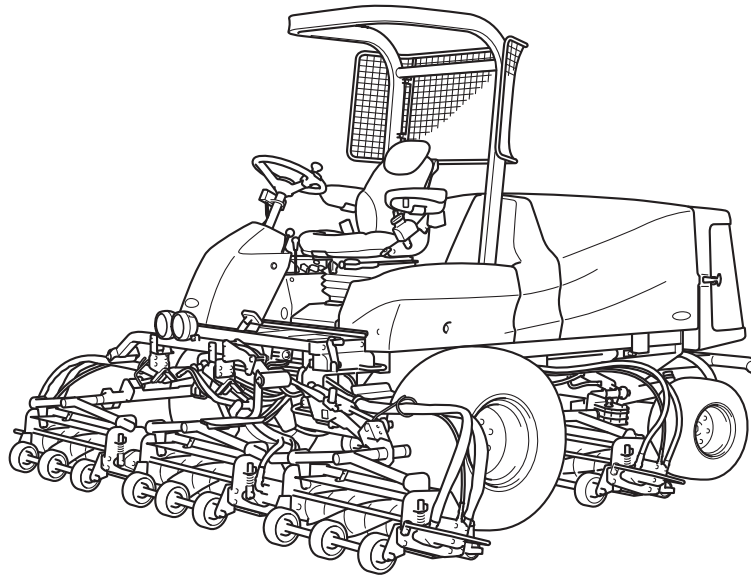

Serial No. LM3210A : 11016-

"Required reading"
Read this manual before using the machine.

BARONESS[®]
Quality on Demand

Original Instructions Ver.1.1

Regulations

California Proposition 65

(For California, USA)

WARNING:

Operating, servicing and maintaining a passenger vehicle or off-road vehicle can expose you to chemicals including engine exhaust, carbon monoxide, phthalates, and lead, which are known to the State of California to cause cancer and birth defects or other reproductive harm. To minimize exposure, avoid breathing exhaust, do not idle the engine except as necessary, service your vehicle in a well-ventilated area and wear gloves or wash your hands frequently when servicing your vehicle. For more information go to www.P65Warnings.ca.gov/passenger-vehicle.

318yi8-005

California Proposition 65_001

California Spark Arrester

(For California, USA)

Warning

Operation of this equipment may create sparks that can start fires around dry vegetation.
A spark arrester may be required.
The operator should contact local fire agencies for laws or regulations relating to fire prevention requirements.

The DPF installed on the engine of this machine meets requirements of California Public Resource Code Section 4443.

EU Emission Control (Stage V)

(For Europe)

Important

No deliberate tampering with or misuse of the engine emissions control system should take place.

Make repairs immediately if the fault codes of PCD (Particulate Control Diagnostic) and NCD (NOx Control Diagnostic) appear.

Tampering with and use without effect of the engine emissions control system are regulatory infringements and they are penalized.

Thank you for purchasing the Baroness product.
This manual describes the proper handling,
adjustment, and inspection of your product.
We hope you will use the product safely, and take
advantage of its best performance.

Keeping The Owner's Operating Manual

Keep this Manual in the bag located in the rear of the seat.

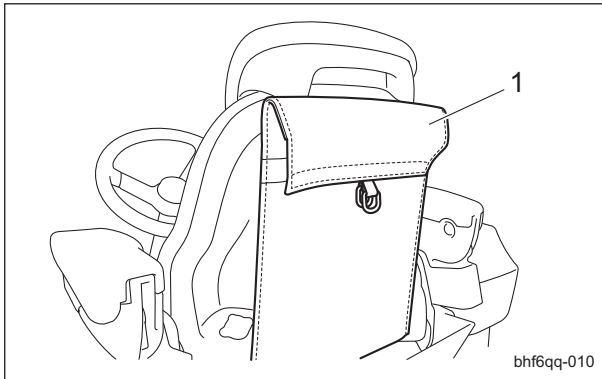

Keeping The Owner's Operating Manual_001

1	Bag
---	-----

Introduction

Read this manual carefully to ensure that you thoroughly understand how to properly operate and maintain the product, and to avoid causing injury to yourself or others.

The operator is responsible for operating the product properly and safely.

Maintenance should only be performed by a certified specialist.

If you have any questions concerning maintenance or genuine parts, please contact a Baroness dealer or Kyoisha.

When making inquiries about the product, please specify the product's model designation and serial number.

When loaning or transferring the product, please also provide this manual together with the product.

Kyoisha Co., Ltd.

Warning Symbols

This manual uses the following warning symbols for handling precautions that are important for your safety.



696cq5-001

Warning symbol

This symbol indicates the articles regarding “Danger,” “Warning,” or “Caution.”

Those articles describe important safety precautions and so read them carefully to understand completely before operating the machine.

Failure to adequately follow these safety precautions may cause an accident.

Danger

This symbol indicates that serious injury or death will occur if the warning is ignored.

Warning

This symbol indicates that serious injury or death may occur if the warning is ignored.

Caution

This symbol indicates that injury or damage to property may occur if the warning is ignored.

Important

This symbol indicates precautions on the mechanism of the machine.

Precautionary Statement

 Caution

The information described in this manual is subject to change for improvement without prior notice.

When replacing parts, be sure to use genuine Baroness parts or parts designated by Kyoisha.

Note that the Baroness product warranty may not apply to defects caused by the use of parts from other companies.

Prior to use, carefully read the following manuals to thoroughly understand the contents for safe and correct operation.

- Baroness Owner's Operating Manual
- The Engine's Owner's Manual
- The Battery's Owner's Manual

Purpose

This product is intended for cutting turf grass at golf courses.

Do not use this product in any way other than its intended purpose, and do not modify this product.

Operating this product for other purposes and modifying it may be very dangerous and may cause damage to the product.

In addition, this product is not authorized for operation as a special motor vehicle. Do not operate it on public roads.

LM3210A

Introduction

Safety	Page 1-1
Safe Operating Practices	Page 1-2
Disposal	Page 2-1
Recycle and Waste Disposal	Page 2-2
Product Overview	Page 3-1
Specifications	Page 3-2
Names of Each Section	Page 3-4
Regulation Decals	Page 3-5
Safety Signs and Instruction Signs	Page 3-8
Handling Instructions	Page 4-1
Inspections	Page 4-3
Tightening Torques	Page 4-14
Adjustment before Work	Page 4-18
Procedure to Start/Stop Engine	Page 4-22
Operation Method	Page 4-24
Instruments	Page 4-37
Travel of Machine	Page 4-73
Cutting Work	Page 4-74
Transporting	Page 4-75
Storage	Page 4-75
Maintenance	Page 5-1
Maintenance Precautions	Page 5-2
Maintenance Schedule	Page 5-2
DPF	Page 5-8
Jacking Up The Machine	Page 5-19
Greasing	Page 5-20
Lubrication	Page 5-26
Maintenance Work	Page 5-29

LM3210A

Contents

Safe Operating Practices Page 1-2

Training Page 1-2

Preparation Page 1-2

Operation Page 1-3

Maintenance and Storage Page 1-4



Safety

Failure to adequately follow these safety precautions may cause an accident resulting in injury or death.

Danger

This product is designed to ensure safe operation and has been tested and inspected thoroughly before shipment from the factory. The product is equipped with safety devices to prevent accidents.

However, whether the product demonstrates its original performance level depends on the manner in which it is operated and handled, as well as the manner in which it is managed on a daily basis.

Inappropriate use or management of the product may result in injury or death.

Observe the following safety instructions to ensure safe operation.

Safe Operating Practices

Training

1. Read this manual and other training material carefully. Be familiar with the controls, safety signs, and the proper use of the equipment.
2. If the operator or mechanic can not read English it is the owner's responsibility to explain this manual to them.
3. All operators and mechanics should seek and obtain professional and practical instruction.
The owner is responsible for training the users.
Such instruction should emphasize.

[1] The need for care and concentration when working with ride-on machines.

[2] Control of a ride-on machine sliding on a slope will not be regained by the application of the brake.

The main reasons for loss of control are

- Insufficient wheel grip
- Being driven too fast
- Inadequate braking
- The type of machine is unsuitable for its task
- Lack of awareness of the effect of ground conditions, especially slopes
- Incorrect hitching and load distribution

4. Never allow children or people unfamiliar with these instructions to use or service the machine.
Local regulations may restrict the age of the operator.
5. The owner/user can prevent and is responsible for accidents or injuries occurring to themselves, other people, or property.
6. Keep in mind that the owner, operator, and mechanic are responsible for accidents or hazards occurring to other people or their property.
7. The ROPS is an integral and effective safety device.
Do not remove or alter the ROPS.
8. Replace a damaged ROPS.
Do not repair or alter.
9. You can find additional safety information where needed throughout this manual.
10. Determine the left and right sides of the machine from the normal operating position.

Preparation

1. Evaluate the terrain to determine what accessories and attachments are needed to properly and safely perform the job. Only use accessories and attachments approved by the manufacturer.
2. While operating, always wear substantial footwear, long trousers, hard hat, safety glasses, and ear protection. Long hair, loose clothing, or jewelry may get tangled in moving parts. Do not operate the equipment when barefoot or wearing open sandals.
3. Inspect the area where the equipment is to be used and remove all objects such as rocks, toys and wire which can be thrown by the machine.
4. Keep children out of the operating area and under the watchful care of a responsible adult other than the operator.

5. Exercise care in the handling of fuel.

 Warning

Warning-Fuel is highly flammable. Take the following precautions.

- [1] Store fuel in containers specifically designed for this purpose.
 - [2] Add fuel before starting the engine. Never remove the cap of the fuel tank or add fuel while the engine is running or when the engine is hot.
 - [3] Refuel outdoors only and do not smoke while refueling.
 - [4] If fuel is spilled, do not attempt to start the engine but move the machine away from the area of spillage and avoid creating any source of ignition until petrol vapours have dissipated.
 - [5] Replace all fuel tanks and container caps securely.
6. Check that operator's presence controls, safety switches and shields are attached and functioning properly. Do not operate unless they are functioning properly.
 7. If the brake operation is faulty or the parking brake lever has noticeable play, be sure to adjust or repair them before operating the machine.
 8. Replace faulty mufflers.
 9. On multi-cylinder/multi-reel machines take care as rotating one cylinder/reel can cause other cylinder/reels to rotate.

Operation

1. Do not operate the engine in a confined space where dangerous carbon monoxide fumes can collect.
2. Only operate in good light, keeping away from holes and hidden hazards.
3. Before attempting to start the engine, disengage all attachments, shift into neutral, and engage the parking brake. Only start engine from the operator's position. Use seat belts if provided.

4. Remember there is no such thing as a safe slope. Travel on grass slopes requires particular care.

To guard against overturning:

- [1] Do not stop or start suddenly when going up or downhill.
 - [2] Engage clutch slowly, always keep machine in gear, especially when traveling downhill.
 - [3] Machine speeds should be kept low on slopes and during tight turns.
 - [4] Stay alert for humps and hollows and other hidden hazards.
 - [5] Never operate across the face of the slope, unless the machine is designed for this purpose.
 - [6] Never drive the machine on a slope with an angle of gradient that is greater than that specified or in a place where there is a danger of the machine slipping.
5. Use extra care while operating machine with a grass catcher or other attachments. They can affect the stability of the machine.
 6. Never operate the machine with damaged guards, shields, or without safety protective devices in place. Be sure all interlocks are attached, adjusted and functioning properly.
 7. Do not change the engine governor settings or overspeed the engine. Operating the engine at excessive speed may increase the hazard of personal injury.
 8. Do the following before leaving the operator's position.
 - [1] Stop on level ground.
 - [2] Disengage the power take-off and lower the attachments.
 - [3] Change into neutral and set the parking brake.
 - [4] Stop the engine and remove the key.
 9. Disengage the drive to attachments, stop the engine, and remove the ignition key in the following conditions.
 - [1] Before refueling.
 - [2] Before making height adjustment unless adjustment can be made from the operator's position.
 - [3] Before cleaning blockages.
 - [4] Before checking, cleaning, or working the machine.

Safety

- [5] After striking a foreign object or if an abnormal vibration occurs.
Inspect the machine for damage and make repairs before restarting and operating the equipment.
10. Keep hands and feet away from the cutting units and the rotating parts.
 11. Do not mow in reverse unless absolutely necessary. Always look down and behind before and while backing.
 12. Do not carry passengers.
 13. Never operate while people, especially children, or pets are nearby.
 14. Slow down and use caution when making turns and crossing roads and sidewalks.
 15. Stop the blades rotating before crossing surfaces other than grass.
 16. Disengage drive to attachments when transporting or not in use.
 17. When using any attachments, never direct discharge of material toward bystanders nor allow anyone near the machine while in operation.
 18. Do not operate the machine under the influence of alcohol or drugs.
 19. Take care when loading or unloading the machine into a trailer or a truck. Load or unload the machine in a flat and safe place. Before loading or unloading, set the parking brake on the truck or trailer, stop the engine, and chock the wheels.
When transporting the machine on a truck or a trailer, set the parking brake, stop the engine, and fasten the machine to the truck with a rope or other suitable restraining device that has sufficient strength.
When using a loading ramp, select one with sufficient strength, length, and width and that will not cause the machine to slip.
 20. Close the fuel valve before transporting the machine.
 21. Use care when approaching blind corners, shrubs, trees, or other objects that may obscure vision.
 22. Do not take your eyes off the road ahead. Do not operate the machine with no hands.
 23. Reduce the throttle setting during engine run-out and, if the engine is provided with a shut-off valve, turn the fuel off at the conclusion of operation.

24. Do not operate the machine when there is the risk of lightning.

Maintenance and Storage

1. Disengage drives on level ground, lower the attachments, set parking brake, stop engine and remove key from ignition. Wait for all movement to stop before adjusting, cleaning or repairing.
2. When machine is to be parked, stored, or left unattended, lower the cutting units unless a positive mechanical lock is provided.
3. To reduce the fire hazard, keep the engine, silencer/muffler, battery compartment fuel storage area, cutting unit and drives free of grass, leaves, or excessive grease. Clean up oil or fuel spillage.
4. Allow the engine to cool before storing in any enclosure.
5. Only cover the machine with a sheet after hot parts have sufficiently cooled down.
6. Never store the equipment with fuel in the tank inside a building where fumes may reach an open flame or spark.
7. If the engine is provided with a shut-off valve, shut off valve while storing or transporting.
8. Do not store fuel near flames.
9. Never allow untrained personnel to service machine.
10. Allow the engine/muffler to cool before checking/maintenance.
11. Appropriately manage and correctly use the tools necessary for servicing or adjusting the machine.
12. Use jack stands to support components when required.
13. Carefully release pressure from components with stored energy.
14. Be sure to depressurize the hydraulic system before performing maintenance operations on it such as removing hydraulic equipment.
15. Check whether line connectors in the hydraulic system are properly tightened. Before applying hydraulic pressure, check the connections of the hydraulic pressure lines and the condition of the hoses.

16. When checking the hydraulic circuit for pinhole leaks or oil leakage from nozzles, do not use your hands. Use items such as paper or corrugated cardboard to find leakage points. Be extremely careful with high-pressure oil as it may pierce your skin, resulting in an injury.
If fluid is injected into the skin it must be surgically removed within a few hours by a doctor familiar with this form of injury or gangrene may result.
17. Disconnect battery before making any repairs. Disconnect the negative terminal first and the positive last. Reconnect positive first and negative last.
18. Make sure that parts such as wires are not touching each other and that their covers have not come off.
19. Use care when checking the cylinders/reels and bed knives.
 - [1] Wear gloves and use caution when servicing them.
 - [2] Be careful during adjustment of the machine to prevent entrapment of the fingers between moving blades and fixed parts of the machine.
20. On multi-cylinder/multi-reel machines take care as rotating one cylinder/reel can cause other cylinder/reels to rotate.
21. Keep hands and feet away from moving parts. If possible, do not make adjustments with the engine running.
22. Charge batteries in an open well ventilated area, away from spark and flames. Unplug charger before connecting or disconnecting from battery. Wear protective clothing and use insulated tools.
23. Keep all parts in good working condition and all hardware tightened. Replace all worn or damaged decals.
24. Keep all nuts, bolts and screws tight to be sure the equipment is in safe working condition.
25. If the fuel tank has to be drained, do this outdoors.
26. Swallowing engine coolant can cause injury or death; keep out of reach from children and pets.

Recycle and Waste Disposal Page 2-2

About RecyclePage 2-2

About Waste Disposal Page 2-2

Disposal

Recycle and Waste Disposal

About Recycle

Recycling battery etc. is recommended for environmental conservation and economical use of resources.

It may be required by local laws.

About Waste Disposal

Make sure that waste generated when servicing or repairing the machine is disposed of in accordance with local regulations. (e.g. waste oil, antifreeze, rubber products, and wires etc.)

Specifications Page 3-2

SpecificationsPage 3-2

Sound Pressure Level Page 3-3

Sound Power Level Page 3-3

Vibration LevelPage 3-3

Carbon Dioxide (CO₂) Emissions

MeasurementPage 3-3

Names of Each Section Page 3-4**Regulation DecalsPage 3-5**

Positions of Regulation Decals Page 3-5

Description of Regulation Decals Page 3-5

Safety Signs and Instruction Signs Page 3-8

About Safety Signs and Instruction

SignsPage 3-8

Positions of Safety Signs and

Instruction Signs Page 3-8

Description of Safety Decals and

Instruction Decals Page 3-10

Product Overview

Specifications

Specifications

Model		LM3210A (Type_F)		LM3210A (Type_R)		
Dimensions	Total length	124.06 in	315 cm	129.92 in	330 cm	
	Total width	During operation	144.49 in	367 cm	144.88 in	368 cm
		During transport	92.52 in	235 cm	92.91 in	236 cm
	Total height	Roof	92.91 in	236 cm	93.31 in	237 cm
Steering handle		64.96 in	165 cm	65.35 in	166 cm	
Weight	Machine (empty fuel tank) with ROPS, Roof	4265.87 lb	1,935 kg	4287.92 lb	1,945 kg	
	CR Brush (for one machine)	48.50 lb	22.0 kg	-	-	
Minimum turning radius		125.98 in	320 cm	←		
Engine	Model	Kubota V2403-CR-TE5B		←		
	Type	Vertical water-cooled 4-cycle diesel engine with turbocharger		←		
	Total displacement	148.51 cu.in.	2,434 cm ³ (2.434 L)	←		
	Maximum output	43.2 kW (58.7 PS)/2,400 rpm		←		
Fuel tank capacity		Diesel 13.47 U.S.gals	Diesel 51.0 dm ³ (51.0 L)	←		
Fuel consumption		182 g/PS · h (rated output)	248 g/kW · h (rated output)	←		
Engine oil capacity		2.56 U.S.gals	9.7 dm ³ (9.7 L)	←		
Coolant volume		3.17 U.S.gal.	12.0 dm ³ (12.0 L)	←		
Hydraulic tank capacity		11.62 U.S.gal.	44.0 dm ³ (44.0 L)	←		
Operating width (Mowing width)		125.98 in	320 cm	←		
Operating height (Mowing height)		0.394 - 2.362 in	10 - 60 mm	0.669 - 2.677 in	17 - 68 mm	
Blades		7		5		
Drive	Traveling	HST (2WD/4WD selectable)		←		
	Mowing	Hydraulic		←		
Speed (HST)	Forward	2WD 0 - 9.63 mph	2WD 0 - 15.5 km/h	←		
		4WD 0 - 6.22 mph	4WD 0 - 10.0 km/h	←		
	Reverse	0 - 3.73 mph	0 - 6.0 km/h	←		
Speed (Mechanical)		-		←		
Efficiency		8.22 acres/hour (2WD : 8.08 mph x Mowing width x 0.8)	33,280 m ² /h (2WD : 13.0 km/h x Mowing width x 0.8)	←		
Maximum inclination for operation		15 degrees		←		
Tire size	Front wheel	31 x 13.50 - 15		31 x 15.50 - 15		
	Rear wheel	20 x 12.00 - 10		←		
Tire pneumatic pressure	Front wheel	20.30 psi	140 kPa (1.4 kgf/cm ²)	←		
	Rear wheel	20.30 psi	140 kPa (1.4 kgf/cm ²)	←		
Battery		105D31R		←		
Engine plug		-		←		

* The factory default maximum engine rpm is 2,600 rpm.

Sound Pressure Level

Sound Pressure Level

This machine was confirmed to have a continuous A-weighted sound pressure level of 88 dB by measuring identical machines in accordance with the procedure specified in ISO5395-1:2013.

Sound Power Level

Sound Power Level

This machine was confirmed to have a sound power level of 105dB by measuring identical machines in accordance with the procedure specified in directive 2000/14/EC.

Vibration Level

Hand-Arm Vibration

This machine was confirmed not to exceed a vibration level of 2.5 m/s² to hands and arms by measuring identical machines in accordance with the procedure specified in ISO 5395-1:2013.

Whole Body Vibration

This machine was confirmed not to exceed a vibration level of 0.5 m/s² to the whole body by measuring identical machines in accordance with the procedure specified in ISO 5395-1:2013.

Carbon Dioxide (CO₂) Emissions Measurement

For CO₂ emissions measurement on the engine of this machine, refer to the engine's owner's manual.

Product Overview

Names of Each Section

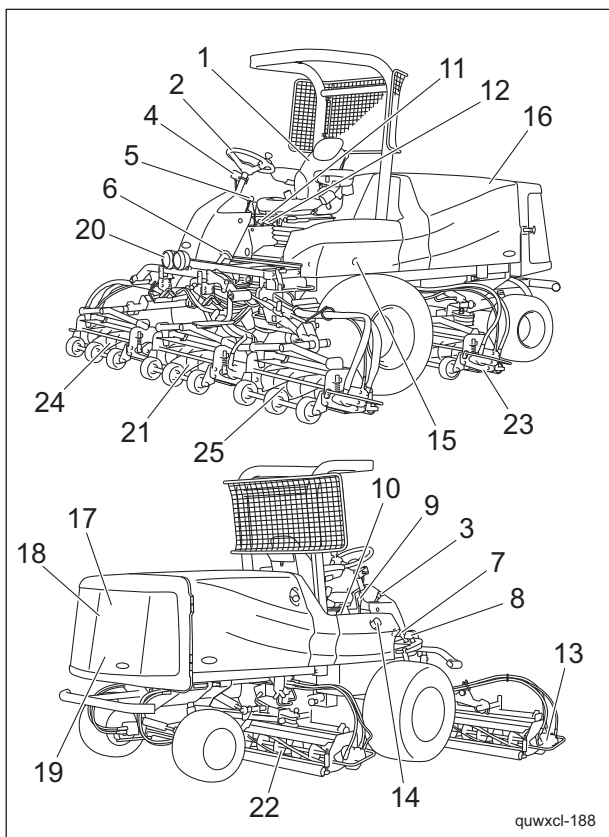

Names of Each Section_001

1	Seat
2	Steering handle
3	Tilt lever
4	Diff-lock switch
5	Parking brake lever
6	Brake pedal
7	Forward pedal
8	Reverse pedal
9	Mower unit up/down lever
10	Throttle knob
11	Reel rotation switch
12	2WD/4WD selector switch
13	Reel rotation/stop switching lever
14	Fuel tank
15	Hydraulic tank
16	Hood
17	Radiator
18	Oil cooler
19	Radiator cover
20	Light
21	Mower unit #1
22	Mower unit #2
23	Mower unit #3
24	Mower unit #4
25	Mower unit #5

Product Overview

Regulation Decals

Positions of Regulation Decals

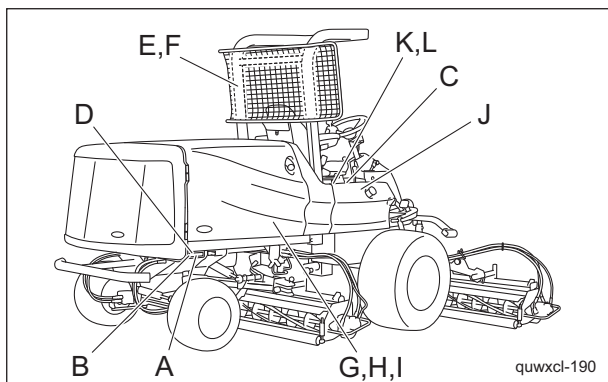

Positions of Regulation Decals_001

A	Serial number plate
B	Specification decal
C	Noise emission decal
D	Year of manufacture decal
E	ROPS compliance decal
F	ROPS caution decal
G	Battery capacity decal
H	Recycle decal
I	Battery danger decal
J	Indicating diesel fuel decal
K	California proposition 65 decal (riding type)
L	Spark arrester warning decal

Description of Regulation Decals

Serial Number Plate

The serial number plate indicates the model and serial number of the machine.

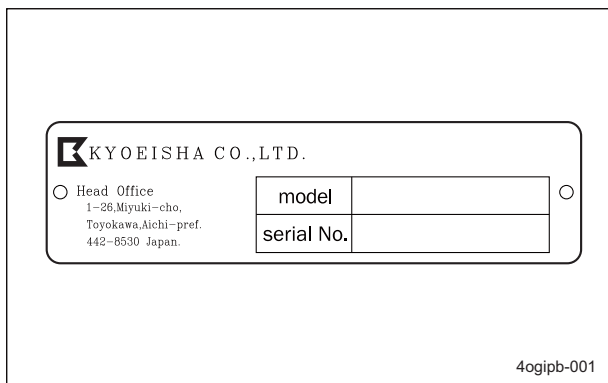

Serial Number Plate_001

Specification Decal

(For Europe)

The Specification decal indicates the CE marking, model, and weight, etc.

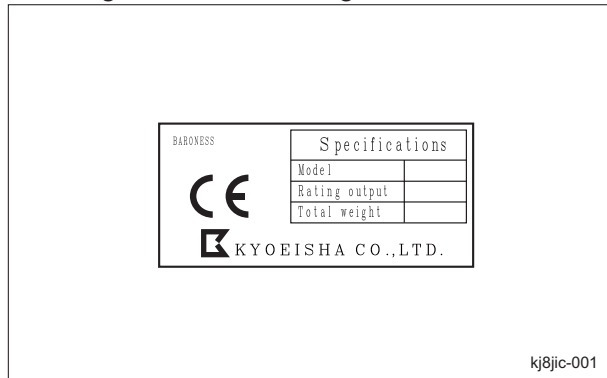

Specification Decal_001

Noise Emission Decal

(For Europe)

The noise emission decal indicates the sound power level determined by measuring identical machines in accordance with the procedure specified in the EC directives.

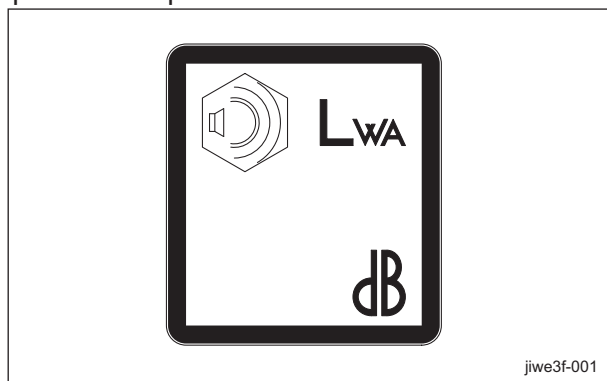

Noise Emission Decal_001

Year of Manufacture Decal

(For Europe)

The year of manufacture decal indicates the year when this machine was manufactured.



Year of Manufacture Decal_001

Product Overview

ROPS Compliance Decal

The ROPS compliance decal indicates the manufacturer, model, etc., in accordance with International Standard ISO 21299:2009.

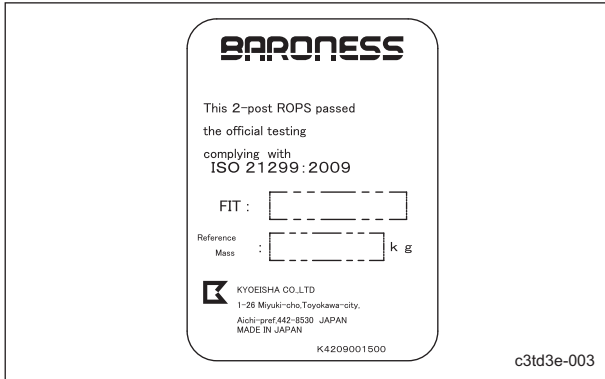

ROPS Compliance Decal_001

Recycle Decal

Recycle Decal illustrates Recycle Mark in accordance with local regulation. (For Europe)

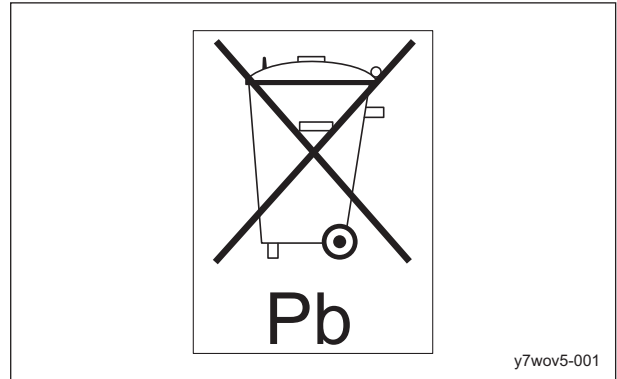

Recycle Decal_001

ROPS Caution Decal

ROPS caution decal describes the following caution messages.

- Replace damaged ROPS.
- Do not repair or revise.

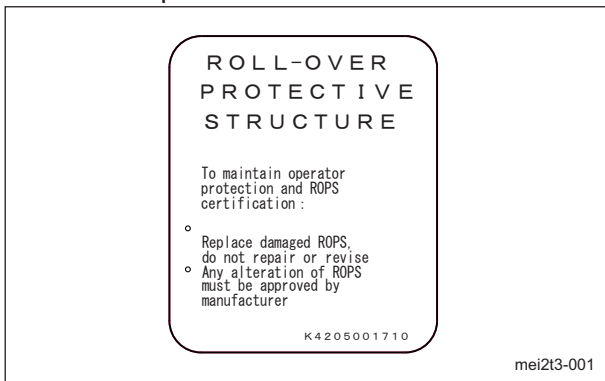

ROPS Caution Decal_001

(For USA)



Recycle Decal_002

Battery Danger Decal

(For USA)

Battery Danger Decal describes handling precautions for battery.

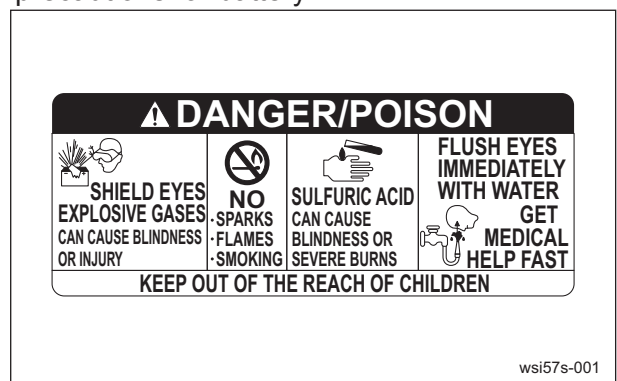

Battery Danger Decal_001

Battery Capacity Decal

(For Europe)

The battery capacity decal indicates the capacity by 20HR and CCA.

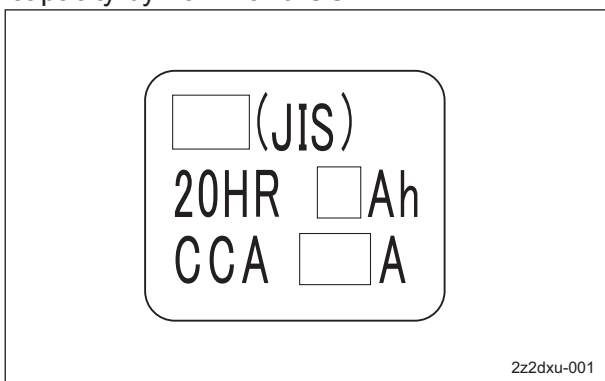

Battery Capacity Decal_001

Indicating Diesel Fuel Decal

(For USA)

Indicating diesel fuel decal describes the type of fuel to be used.

Use Ultra Low Sulfur Diesel Fuel (sulfur-free diesel).

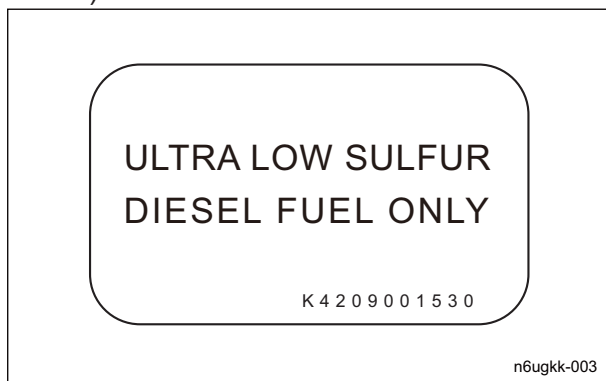

Indicating Diesel Fuel Decal_001

Spark Arrester Warning Decal

(For the State of California, USA)

Spark arrester warning decal describes the warning messages as required by California Public Resources Code.

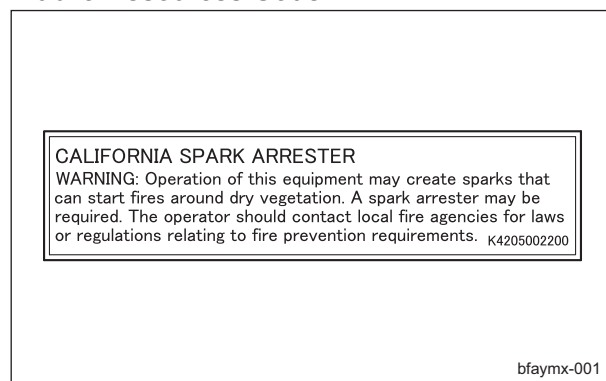

Spark Arrester Warning Decal_001

California Proposition 65 Decal (Riding Type)

(For the State of California, USA)

California Proposition 65 decal describes the warning messages as required by California Proposition 65.

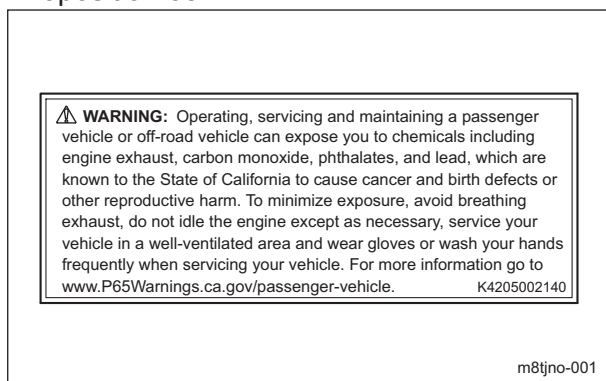

California Proposition 65 Decal (Riding Type)_001

Product Overview

Safety Signs and Instruction Signs

About Safety Signs and Instruction Signs

Important

Safety decals and instruction decals are attached to this product. Make sure that they are preserved in their entirety. If they are damaged, become dirty, or peel off, replace them with new ones.

Part numbers for decals that need to be replaced are listed in the parts catalog. Order them from a Baroness dealer or Kyoeshia.

Positions of Safety Signs and Instruction Signs

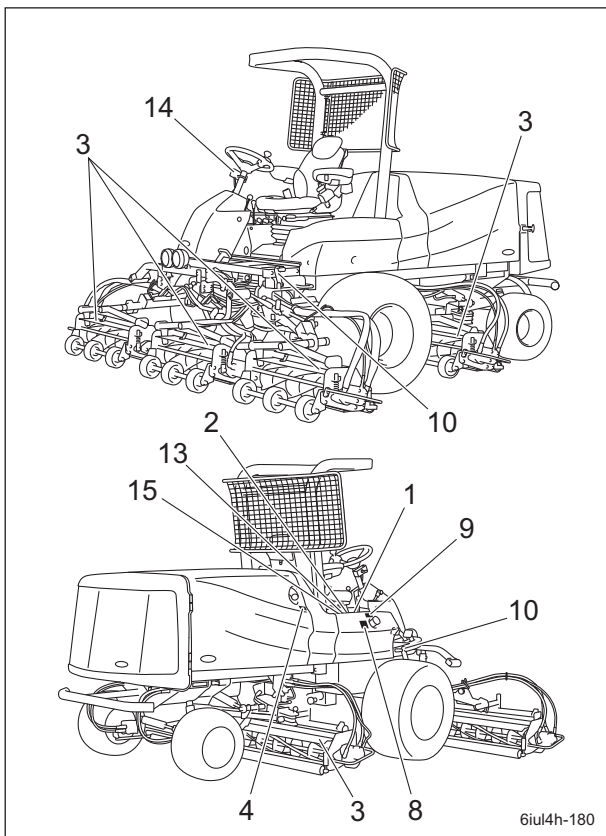

Positions of Safety Signs and Instruction Signs_001

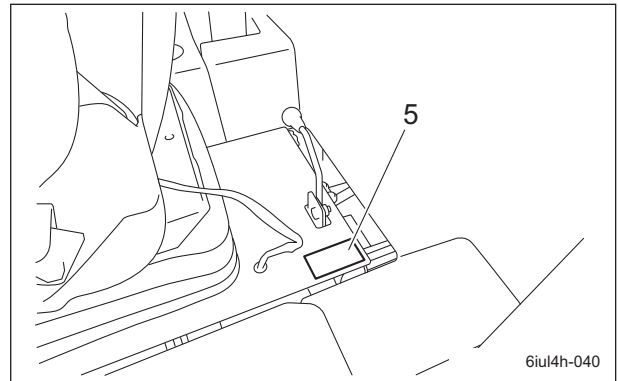

Positions of Safety Signs and Instruction Signs_002

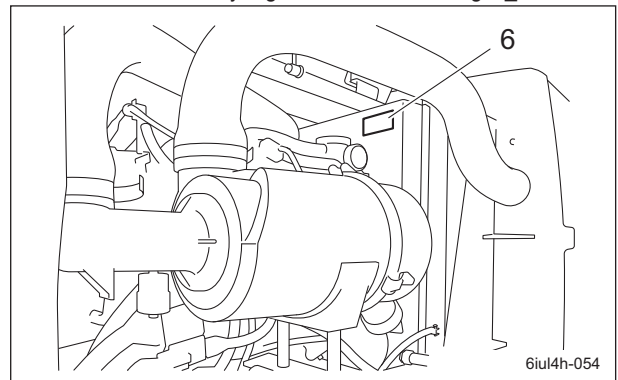

Positions of Safety Signs and Instruction Signs_003

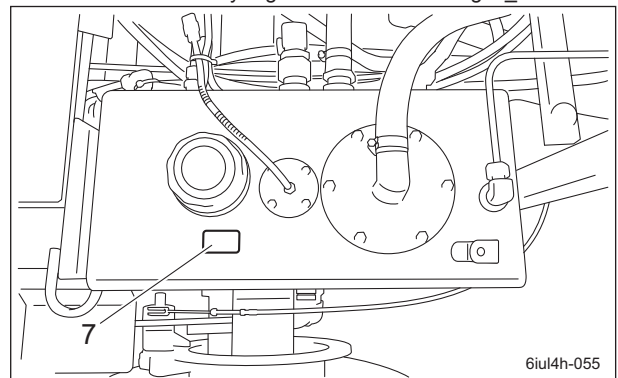

Positions of Safety Signs and Instruction Signs_004

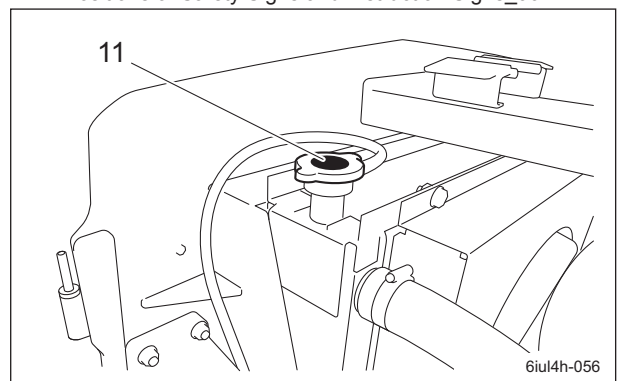

Positions of Safety Signs and Instruction Signs_005

Product Overview

Product Overview

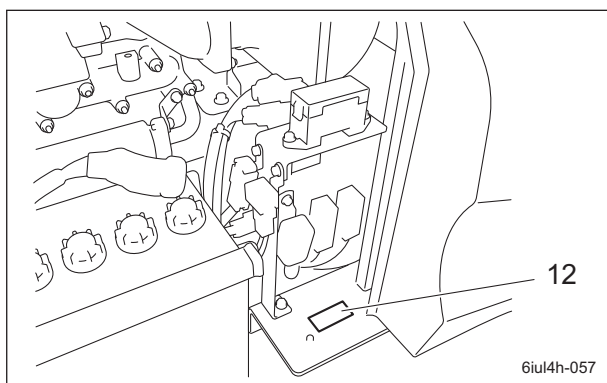

Positions of Safety Signs and Instruction Signs_006

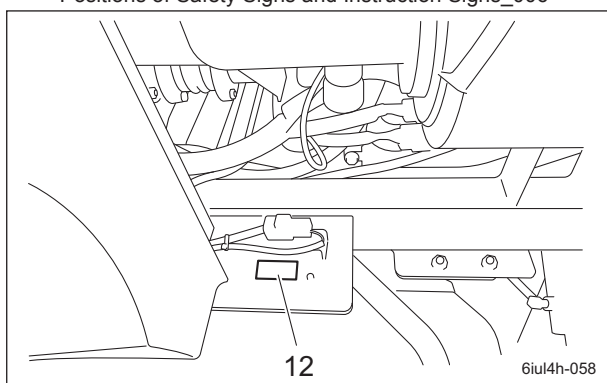

Positions of Safety Signs and Instruction Signs_007

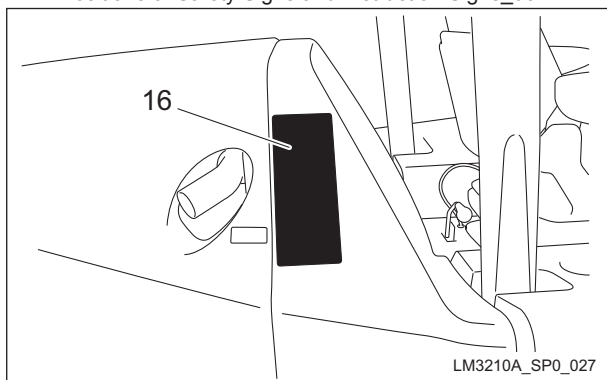

Positions of Safety Signs and Instruction Signs_008

1	Operation decal
2	Start/stop decal (reel)
3	Caution to mutilation decal
4	Caution for high temperatures decal
5	Caution to injury decal
6	Caution to rotating object decal
7	Hydraulic oil icon
8	Diesel fuel icon
9	Fire prohibited decal
10	Caution for mower lock decal
11	Caution for spouting coolant decal
12	Caution to getting pinched decal
13	Caution exhaust gas decal
14	Engine warning lamp decal (EN)
15	Caution to noise decal
16	Maintenance decal

Product Overview

Description of Safety Decals and Instruction Decals

Operation Decal

LM3210A0901Z0
Decal, operation

1.

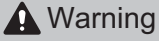
 **Warning**
Read the Owner's Operating Manual.

2.

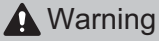
 **Warning**
Apply the parking brake, stop the engine, remove the ignition key, and then leave the machine.

3.

 **Caution**
Flying objects - Be sure that people around the machine keep a safe distance away.

4.

 **Warning**
May cut your hand or leg - Keep hands and feet away from moving parts.

5.

 **Caution**
Rollover - Do not work on slopes of 15 degrees or more.
When you descend a slope, lower the mower units and then drive at low speed.
For ROPS equipped machine, fasten your seatbelt.

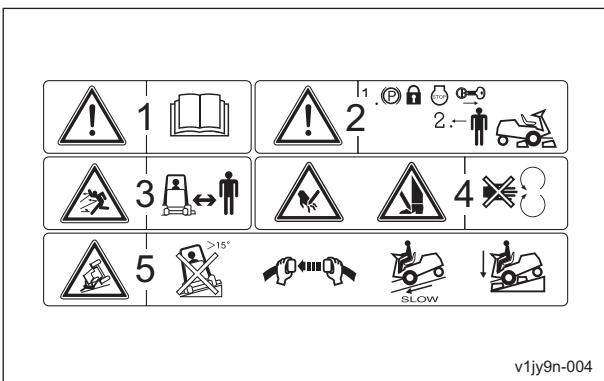

Operation Decal_001

Start/Stop Decal

K4205001840

Sticker, reel start/stop

1.

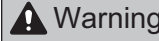
 **Warning**
Read the Owner's Operating Manual.

2. Procedure to Start Engine

Read the Owner's Operating Manual.

[1] Sit on the seat.

[2] Turn the key to the "ON (GLOW)" position, and then wait for the "BARONESS" logo to turn off.

[3] Turn the key to the "START" position.

[4] Depress the brake pedal to release the parking brake.

3. Procedure to Stop Engine

Read the Owner's Operating Manual.

[1] Set the reel rotation switch to the "OFF" position, and then raise the mower units.

[2] Apply the parking brake.

[3] Turn the key to the "OFF" position, and then remove it.

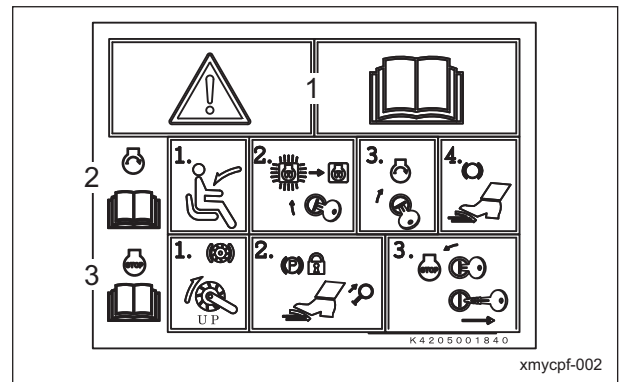

Start/Stop Decal_001

Caution to Mutilation Decal

K4205001600
DECAL, CAUTION TO MUTILATION

Warning

May cut your hand or leg - Stop the cutter rotation and engine. Otherwise you may get injured.

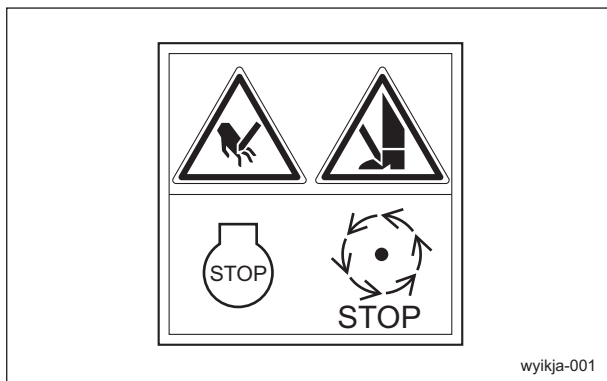

Caution to Mutilation Decal_001

Caution to Injury Decal

K4205001580
Decal, caution to injure

Caution

May pinch - There is a risk of being pinched.

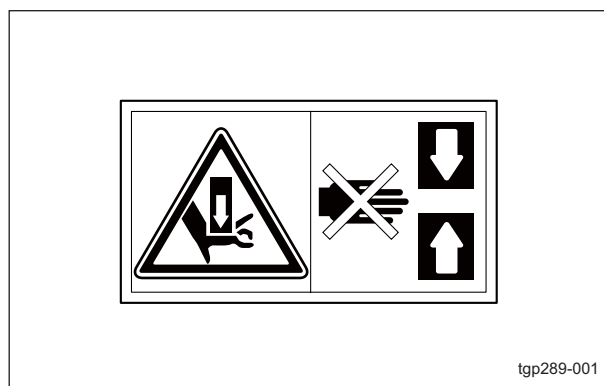

Caution to Injury Decal_001

Caution for High Temperatures Decal

K4205001920
Decal, caution for high temperatures

Caution

High temperature - Do not touch. Otherwise, you will get burned.



Caution for High Temperatures Decal_001

Caution to Rotating Object Decal

K4205001530
Decal, caution to rotating object

Warning

Watch for rotating parts - Keep your hands away from the belts while the engine is running.

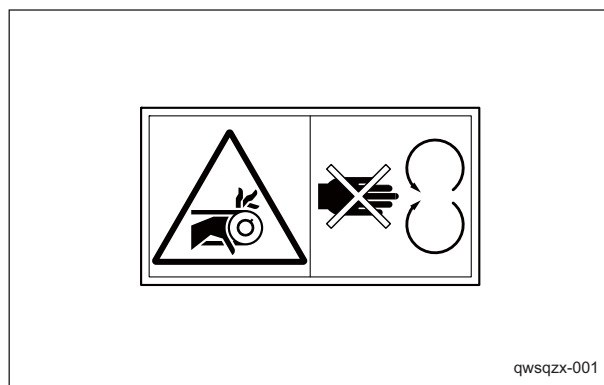

Caution to Rotating Object Decal_001

Product Overview

Hydraulic Oil Icon

K4209000980
Hydraulic oil icon
Read the Owner's Operating Manual.

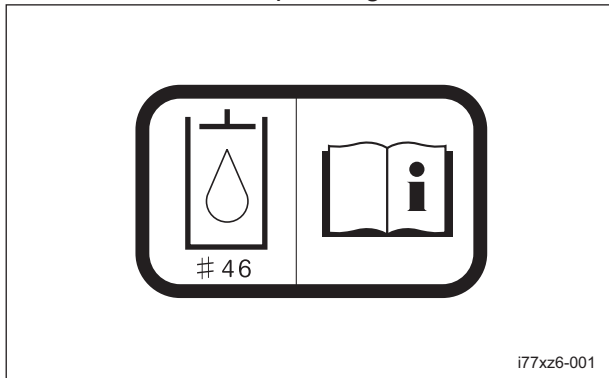

Hydraulic Oil Icon_001

Diesel Fuel Icon

K4209001000
Diesel fuel icon
Use diesel fuel.

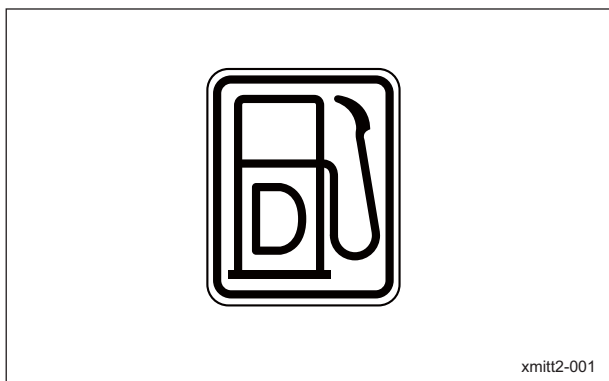

Diesel Fuel Icon_001

Fire Prohibited Decal

K4205001940
Decal, fire prohibited

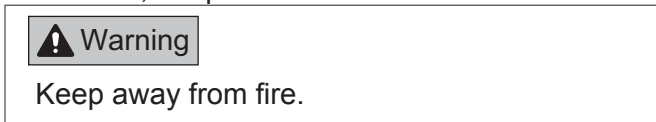

Fire Prohibited Decal_001

Caution for Mower Lock Decal

K4205001900
Decal, caution for mower lock
Lock the mower units when traveling or storing with the mower units #4 and 5 raised.



Caution for Mower Lock Decal_001

Caution for Spouting Coolant Decal

K4205001970
Decal, caution for spouting coolant

Caution

Caution for spouting coolant - Do not open while hot.
High temperature - Do not touch. Otherwise, you will get burned.

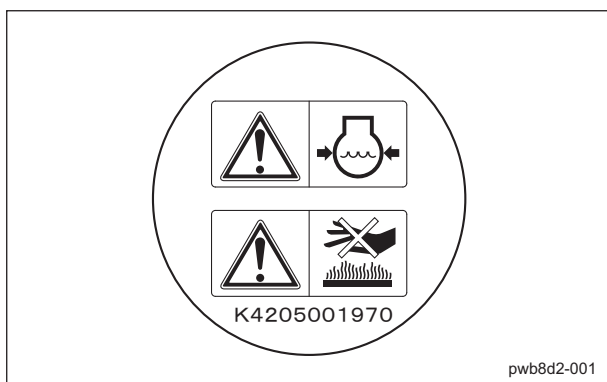

Caution for Spouting Coolant Decal_001

Caution to Getting Pinched Decal

K4205001930
Decal, caution to getting pinched

Caution

May pinch - There is a risk of being pinched.

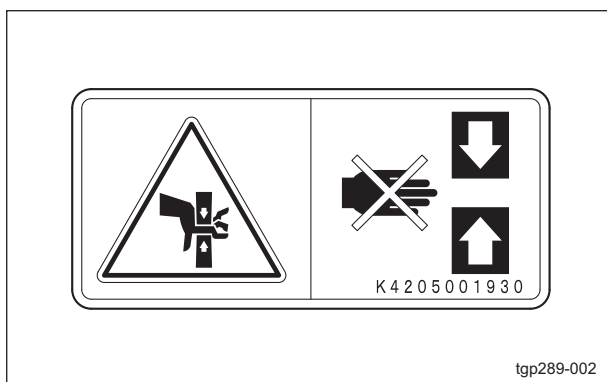

Caution to Getting Pinched Decal_001

Caution Exhaust Gas Decal

K4205001950
Decal, caution exhaust gas

Warning

Caution for exhaust gas

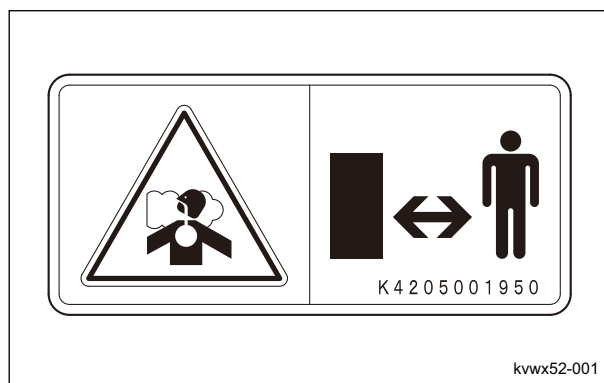

Caution Exhaust Gas Decal_001

Engine Warning Lamp Decal

K4205002270
Decal, Engine Warning Lamp

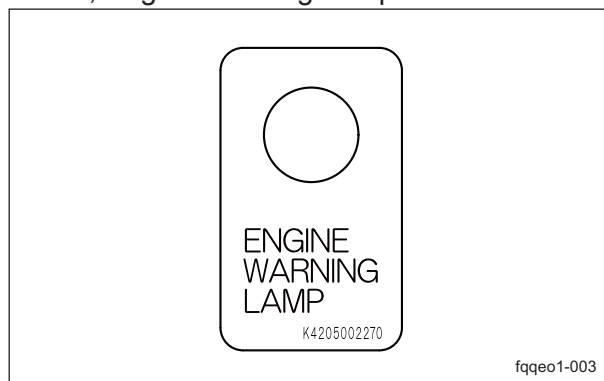

Engine Warning Lamp Decal_001

Product Overview

Caution to Noise Decal

K4205002090

Decal, caution to noise

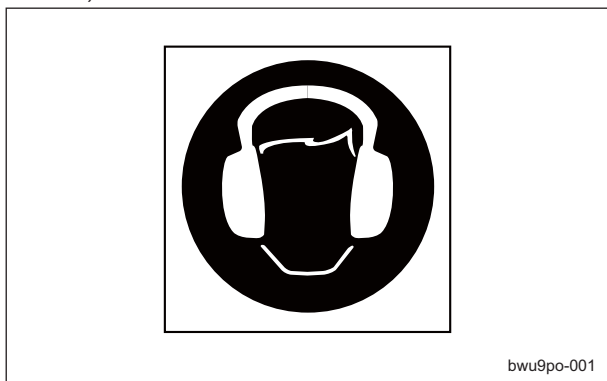

Caution to Noise Decal_001

Maintenance Decal

K4209001550

Label, maintenance

The maintenance decal indicates the necessary inspection and maintenance items for this machine.

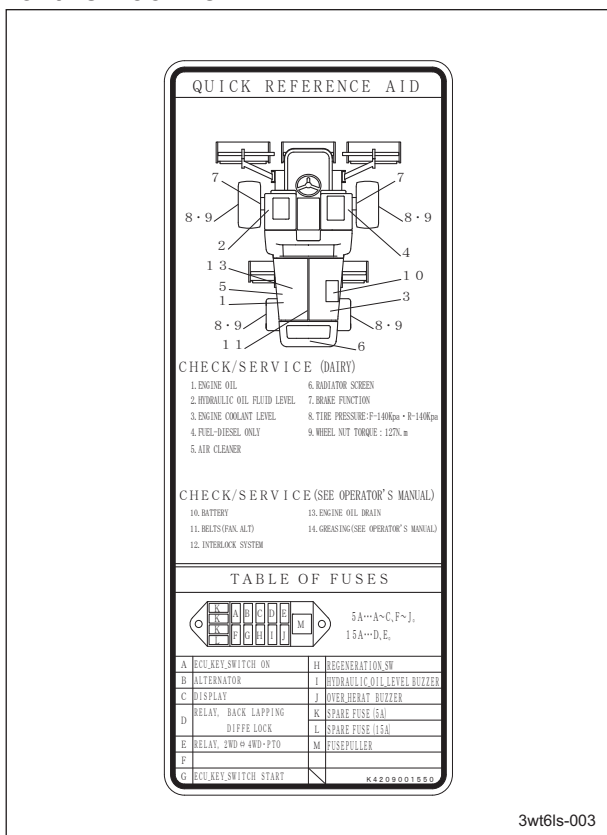

Maintenance Decal_001

Handling Instructions

Inspections	Page 4-3	Operation Method	Page 4-24
Reel Cutter (Cutting Cylinder) and Bed Knife (Bottom Blade)	Page 4-3	Cautions for when You Leave The Machine	Page 4-24
Cover	Page 4-3	Positions of Operation Decals	Page 4-24
Roller	Page 4-3	Description of Operation Decals	Page 4-25
CR brush	Page 4-4	Proximity Sensors	Page 4-29
Radiator Cover	Page 4-4	Relays	Page 4-29
Radiator	Page 4-4	Reel Rotation Switch	Page 4-30
Coolant	Page 4-5	2WD/4WD Selector Switch	Page 4-30
Oil Cooler	Page 4-6	DPF Auto Regeneration Inhibit Switch	Page 4-31
Hydraulic Oil	Page 4-6	DPF Parked Regeneration Switch	Page 4-32
Air Cleaner	Page 4-7	Light Switch	Page 4-32
Battery	Page 4-8	Reel Reverse Switch	Page 4-33
Tire	Page 4-9	Reel Rotation/Stop Switching Lever ...	Page 4-33
Brake	Page 4-9	Reel Rotation Adjustment Valve	Page 4-34
Belt	Page 4-10	Mower Lock Lever (Latch)	Page 4-34
Wire	Page 4-10	Mower Unit Up/Down Lever	Page 4-34
Around The Engine	Page 4-10	Throttle Knob	Page 4-35
Engine Oil	Page 4-10	Diff-Lock Switch	Page 4-35
Fuel	Page 4-11	Traveling Pedal	Page 4-36
Water Separator	Page 4-12	Brake Pedal	Page 4-36
Fuel Filter	Page 4-13	Parking Brake Lever	Page 4-36
Oil Leakage	Page 4-13	Hood	Page 4-37
Tightening Torques	Page 4-14	Underseat Cover	Page 4-37
Standard Tightening Torques	Page 4-14	Instruments	Page 4-37
Principal Tightening Torques	Page 4-16	Description of Monitor	Page 4-37
Adjustment before Work	Page 4-18	Displayed Icon	Page 4-38
Adjustment of Steering Wheel	Page 4-18	Main Menu Items	Page 4-39
Adjustment of Seat	Page 4-18	Engine Warning Lamp	Page 4-72
Adjustment of Blade Engagement	Page 4-19	Travel of Machine	Page 4-73
Adjustment of Cutting Height	Page 4-19	Moving The Machine	Page 4-73
Adjustment of Cutter Adjustment Spring	Page 4-21	Towing The Machine	Page 4-73
Adjustment of Reel Cover	Page 4-21	Cutting Work	Page 4-74
Adjustment of CR Brush	Page 4-22	Cutting Work	Page 4-74
Procedure to Start/Stop Engine	Page 4-22	Transporting	Page 4-75
Start/Stop of Engine	Page 4-22	Transporting Procedure	Page 4-75
Safety Mechanisms	Page 4-23	Storage	Page 4-75
Warning Mechanisms	Page 4-24		

Handling Instructions

Before Long-Term StoragePage 4-75

Handling Instructions

Inspections

Inspect the machine according to the maintenance schedule so that you will be able to take advantage of its optimum performance for a long period of time.

Reel Cutter (Cutting Cylinder) and Bed Knife (Bottom Blade)

Inspection of Reel Cutter (Cutting Cylinder) and Bed Knife (Bottom Blade)

The reel cutter (cutting cylinder) and bed knife (bottom blade) may become dull due to frequent use, objects crushed during mowing, or damage caused during transportation. Inspect the reel cutter (cutting cylinder) and bed knife (bottom blade), and if necessary, adjust the blade engagement, perform back lapping, or sharpen or replace the reel cutter (cutting cylinder) and the bed knife (bottom blade).

1. Check to see whether or not the edge of the reel cutter (cutting cylinder) and the bed knife (bottom blade) are too blunt to cut.
2. Make sure that the reel cutter (cutting cylinder) and the bed knife (bottom blade) are not cracked.
3. Check to see how much the reel cutter (cutting cylinder) and the bed knife (bottom blade) are worn.
4. Make sure that the reel cutter (cutting cylinder) and the bed knife (bottom blade) have not changed color due to heat from grinding.
5. Check to see whether or not the second edge face (relief) remains at the point of reel cutter (cutting cylinder).
6. Make sure that the welding between the reel cutter (cutting cylinder) and the disc has not come off.

Cover

Inspection of Covers

Warning

If you have removed the covers during inspection, be sure to securely install them in their original positions.

If a cover remains removed, the operator may come into contact with rotating parts or belts and foreign objects may fly off, possibly resulting in injuries.

1. Make sure that there is no wear or deterioration of the reel cover and all other covers.
2. Make sure that there is no damage to the reel cover and all other covers.
3. Make sure that there is no interference with moving parts due to deformation of the reel cover and all other covers.
4. Make sure that the reel cover and all other covers are installed in their appropriate positions.

Roller

Inspection of Rollers

Bearing wear due to frequent use or bearing damage caused by water infiltration may prevent the roller from rotating smoothly. Inspect the roller and, if necessary, replace parts such as oil seals and bearings.

1. Make sure that there is no abrasion nor adhesion of the roller.
2. Make sure that there is no wear of the roller shaft.
3. Make sure that there is no wear nor damage of the oil seal.
4. Make sure that there is no wear nor rust of the bearing.
5. Make sure that there is no play in the roller shaft.

Handling Instructions

CR brush

Inspection of CR Brush

Note:

Depending on the specifications, this function may not be available.

Bearing wear due to frequent use or bearing damage caused by water infiltration may prevent the brush from rotating smoothly. Inspect the brush and, if necessary, replace parts such as bearings.

1. Make sure that there is no abrasion nor adhesion of the brush.
2. Make sure that there is no wear of the brush shaft.
3. Make sure that there is no abnormality in the brush.
4. Make sure that there is no play in the fit of the bearing and the housing.
5. Make sure that there is no play in the brush shaft.

Radiator Cover

Inspection of Radiator Cover

1. Make sure that there is no damage to the radiator cover.
2. Make sure that the radiator cover is not contaminated.

Cleaning of Radiator Cover

Important

An unclean radiator cover may cause overheating or damage to the engine. It may also cause malfunction of the hydraulic system.

If the radiator cover has been contaminated with dust, be sure to clean it.

After operating the machine in a dusty environment, it is important to remove dust from the cover as soon as possible.

1. Open the radiator cover.

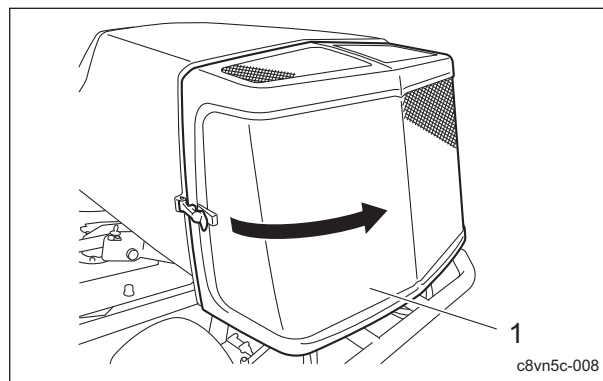

Cleaning of Radiator Cover_001

1	Radiator cover
---	----------------

2. Carefully clean the front and back of the radiator cover with water or compressed air.

Radiator

Inspection of Radiator

1. Make sure that there is no damage to the radiator.
2. Make sure that the radiator is not contaminated.

Cleaning of Radiator

Important

An unclean radiator may cause overheating or damage to the engine. It may also cause malfunction of the hydraulic system.

Important

Do not use solid objects, such as a spatula or screwdriver, or high-pressure water to clean the radiator or oil cooler. Otherwise, special fins or tubes may be damaged, possibly resulting in reduced cooling performance or coolant leakage.

If the radiator has been contaminated with dust, be sure to clean it.

After operating the machine in a dusty environment, it is important to remove dust as soon as possible.

1. Open the radiator cover.

Handling Instructions

- Unlock the rubber catches on the left and right of the oil cooler, and then tilt the oil cooler.

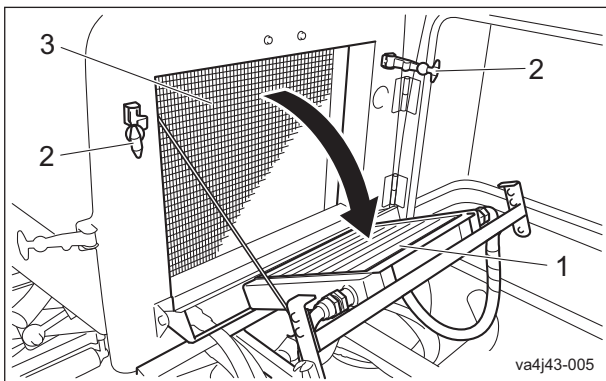

Cleaning of Radiator_001

1	Oil cooler
2	Rubber catch
3	Radiator

- Carefully clean the front and back of the radiator with water or compressed air.

Coolant

Inspection of Coolant

Caution

Do not touch the radiator or coolant during engine operation or immediately after the engine has been turned off. Otherwise, you may get burned.

Caution

Inspection should take place after the engine has well cooled down.

- Make sure that the coolant level in the reserve tank is between "FULL" and "LOW".

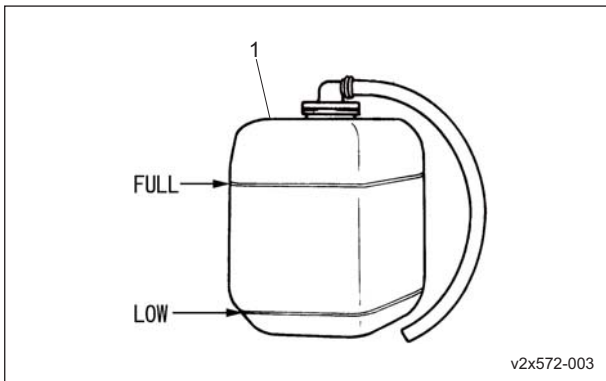

Inspection of Coolant_001

1	Reserve tank
---	--------------

Coolant Supply

Caution

Do not touch the radiator or coolant during engine operation or right after the engine has been turned off. Due to high temperatures, doing so could cause burns.

Caution

Supply coolant after the engine has well cooled down.

Caution

The radiator cap is pressurized. If you remove the radiator cap while the engine is overheated, hot steam will burst out, possibly resulting in burns. Make sure that the water temperature and pressure are reduced, and then grab the cap with a thick cloth and gradually open the cap.

Important

When you supply coolant, be sure to use clean water, such as tap water.

Important

Tightly close the radiator cap. If the cap is loose or incorrectly installed, water may leak and the engine may overheat.

- If the coolant level in the reserve tank is lower than the "LOW" mark, open the reserve tank cap and fill the tank with clean water up to the "FULL" mark.

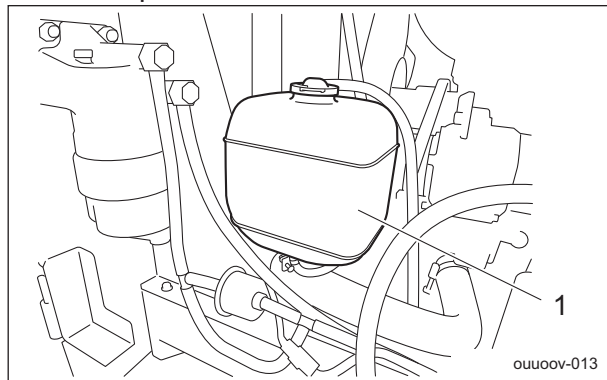

Coolant Supply_001

1	Reserve tank
---	--------------

Handling Instructions

2. If no coolant is in the reserve tank, follow the steps below to fill the tank with clean water.

[1] Open the radiator cap, and then supply clean water up to the opening.

[2] Open the reserve tank cap, and then supply clean water up to the "FULL" mark.

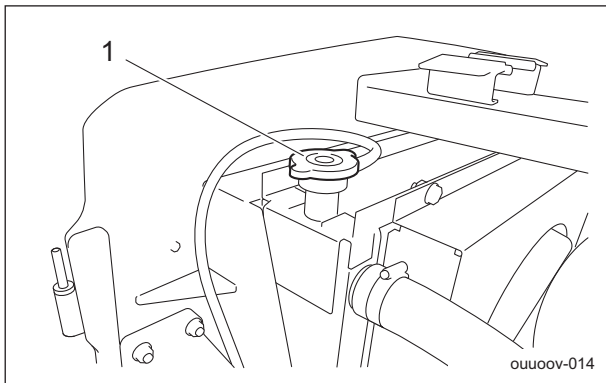

Coolant Supply_002

1	Radiator cap
---	--------------

Oil Cooler

Inspection of Oil Cooler

1. Make sure that there is no damage to the oil cooler.
2. Make sure that the oil cooler is not contaminated.

Cleaning of Oil Cooler

Important

An unclean oil cooler may cause malfunction of the hydraulic system.

Important

Do not use solid objects, such as a spatula or screwdriver, or high-pressure water to clean the radiator or oil cooler.

Otherwise, special fins or tubes may be damaged, possibly resulting in reduced cooling performance or coolant leakage.

If the oil cooler has been contaminated with dust, be sure to clean it. After operating the machine in a dusty environment, it is important to remove dust as soon as possible.

1. Open the radiator cover.

2. Unlock the rubber catches on the left and right of the oil cooler, and then tilt the oil cooler.

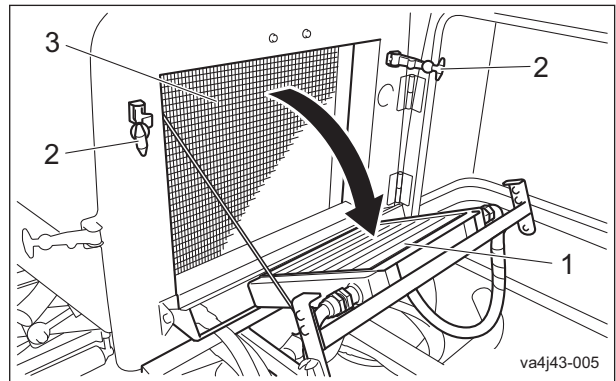

Cleaning of Oil Cooler_001

1	Oil cooler
2	Rubber catch
3	Radiator

3. Carefully clean the front and back of the oil cooler with water or compressed air.

Hydraulic Oil

Inspection of Hydraulic Oil

The oil gauge is on the side of the hydraulic tank.

1. Lower the mower units and maintain that position on a level surface.
2. Make sure that the oil level is at the middle of the oil gauge.

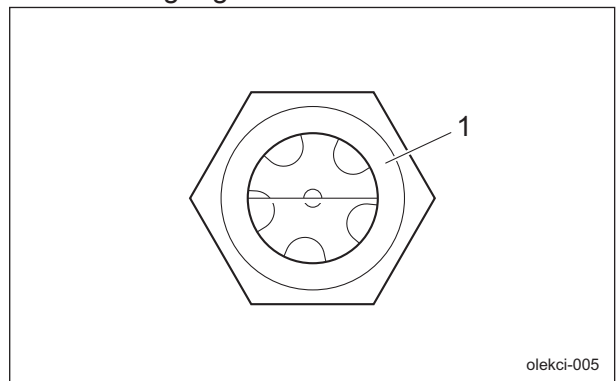

Inspection of Hydraulic Oil_001

1	Oil gauge
---	-----------

3. Check underneath the machine for oil leakage.

Handling Instructions

Hydraulic Oil Supply

Important

Do not mix different types of oil.

Important

Use Shell Tellus S2M46 (or equivalent) as hydraulic oil.

1. If the oil level is low, remove the left tank cover, and then open the tank cap and supply oil.

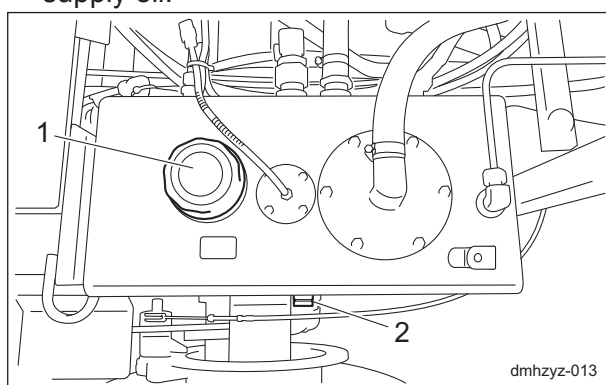

Hydraulic Oil Supply_001

1	Tank cap
2	Oil gauge

2. Tighten the tank cap securely.
3. Start the engine, raise and lower the mower units, and turn the steering wheel left and right.
Move forward and reverse repeatedly several times.
4. Raise the mower units and maintain that position on a level surface, and then check to see if the oil level is at the middle of the oil gauge. If necessary, supply oil.
5. Check underneath the machine for oil leakage.
6. Attach the left tank cover.

Air Cleaner

Inspection of Air Cleaner

Liners and piston rings so that the engine will always operate smoothly.

A contaminated air cleaner element may cause malfunction of the engine.

1. Inspect the air cleaner by checking the vacuum indicator.
If the air cleaner element is contaminated, the vacuum indicator will display a red ring.

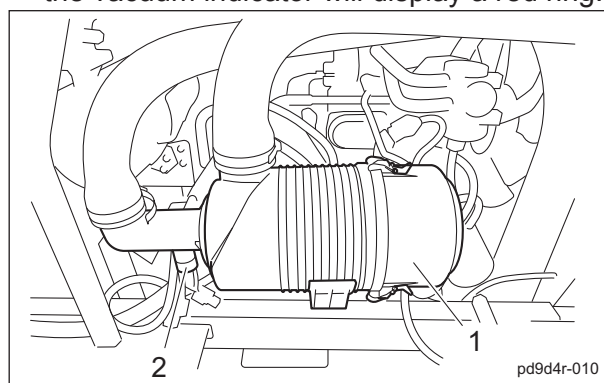

Inspection of Air Cleaner_001

1	Air cleaner
2	Vacuum indicator

2. Make sure that there is no damage to the air cleaner.
3. Make sure that the air cleaner is not contaminated.

Cleaning of Air Cleaner

A contaminated air cleaner element may cause malfunction of the engine.

To maximize the life of the engine, clean the air cleaner properly.

Important

The inner element cannot be cleaned.

1. Follow the steps below to clean the outer element.
 - [1] Remove the clips from the three locations, remove the air cleaner cap, and then remove the outer element.
 - [2] While paying close attention not to damage the outer element, tap a solid portion of the outer element or blow compressed air from its inside to remove dust and dirt.
If the outer element is extremely contaminated, replace it with a new one.

Handling Instructions

- [3] Attach the outer element to the air cleaner body.
- [4] Replace the air cleaner cap, and then fix it securely using the clips.

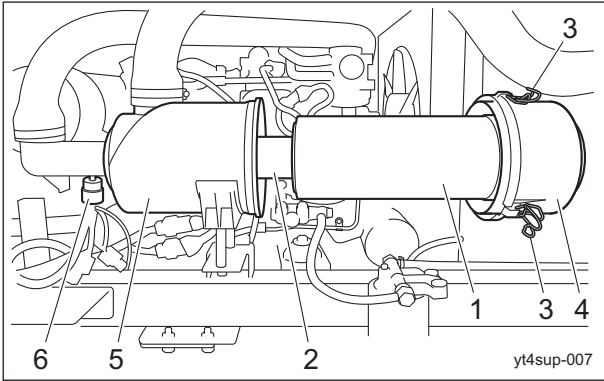

Cleaning of Air Cleaner_001

1	Outer element
2	Inner element
3	Clip
4	Air cleaner cap
5	Air cleaner body
6	Vacuum indicator

- 2. Press the reset button for the vacuum indicator.

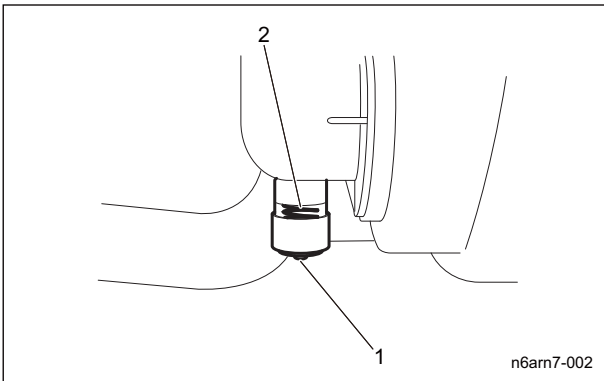

Cleaning of Air Cleaner_002

1	Reset button
2	Vacuum indicator

Battery

Inspection of Battery

Danger

Keep away from fire while inspecting or charging the battery. The battery may explode.

Warning

Do not allow the battery fluid level to become lower than the LOWER LEVEL (minimum fluid level line). The battery may explode if it is used or charged while the battery fluid level is at the LOWER LEVEL (minimum fluid level line).

Caution

Perform operations after the muffler and engine have sufficiently cooled. Otherwise, you may suffer burns.

- 1. Clean the areas around the battery fluid level lines using a cloth damped with water.
- 2. Make sure that the battery fluid level is between the UPPER LEVEL (maximum fluid level line) and the LOWER LEVEL (minimum fluid level line).

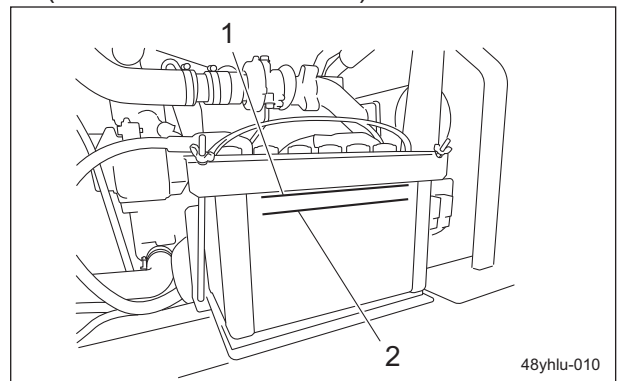

Inspection of Battery_001

1	UPPER LEVEL
2	LOWER LEVEL

Handling Instructions

Supply of Battery Fluid

⚠ Danger

Be careful not to let your skin, eyes or clothes, etc., come into contact with the battery fluid or accidentally swallow the fluid. Should your skin or clothes come into contact with the battery fluid, immediately wash them away with water.

⚠ Danger

When you supply battery fluid, wear protective garments and safety glasses, etc.

⚠ Caution

Implement after the engine and muffler etc. have well cooled down. Otherwise you may get burned.

1. If the battery fluid level is lower than halfway between the UPPER LEVEL (maximum) line and LOWER LEVEL (minimum) line, add purified water up to the UPPER LEVEL (maximum) line.

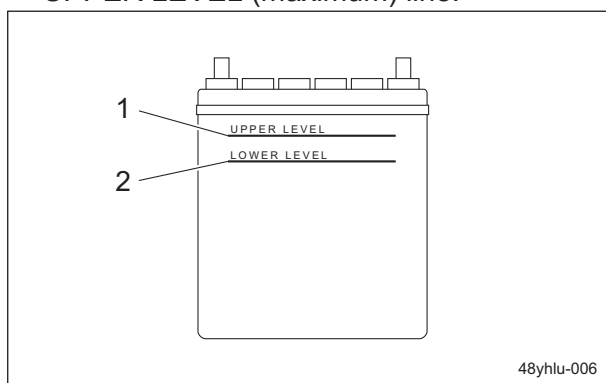

48yhlu-006

Supply of Battery Fluid_001

1	UPPER LEVEL
2	LOWER LEVEL

Tire

Inspection of Tires

1. Check the pneumatic pressure of the tires.
2. Make sure that there are no cracks, damage or abnormal wear.

Type_F

Tire size	Pneumatic pressure
Front wheel (31 x 13.50 - 15)	140 kPa (1.4 kgf/cm ²)
Rear wheel (20 x 12.00 - 10)	140 kPa (1.4 kgf/cm ²)

Type_R

Tire size	Pneumatic pressure
Front wheel (31 x 15.50 - 15)	140 kPa (1.4 kgf/cm ²)
Rear wheel (20 x 12.00 - 10)	140 kPa (1.4 kgf/cm ²)

Brake

Inspection of Brake

While traveling, depress the brake pedal firmly to make sure that the brake is applied effectively.

Inspection of Parking Brake

1. Make sure that the parking brake is applied after depressing the brake pedal and pulling the parking brake lever.
2. Make sure that the parking brake is not applied even slightly after depressing the brake pedal to release the parking brake lever.

Handling Instructions

Belt

Inspection of Belt

Warning

The engine must be stopped when the belt is inspected.

Important

A slacking or damaged belt or damaged fan may cause overheating or lack of a battery charge.

1. Press the middle of the belt with your finger to check the belt tension.
2. Make sure that there are no cracks, damage or abnormal wear.

Wire

Inspection of Wire

1. Make sure that the wire is not cracked or damaged.
2. If the wire is cracked or damaged, replace it with a new one immediately.

Around The Engine

Inspection of Engine-Associated Parts

Caution

Implement after the engine and DPF etc. have well cooled down. Otherwise you may get burned.

1. Check the fuel system parts for loosened or cracked joints and leakage. Replace the parts if necessary.
2. Blow compressed air to clean any grass or flammable materials that may be attached on or around the DPF. Remove clippings and dust in a gap thoroughly due to the intricately shaped engine.

Engine Oil

Inspection of Engine Oil

Important

Securely tighten the oil level gauge and oil filler cap.

1. Stop the engine, wait for 10 to 20 minutes for the engine to cool down, and then check the oil level.
2. Position the machine so that the engine will be level, and then insert the oil level gauge all the way to check the oil level.

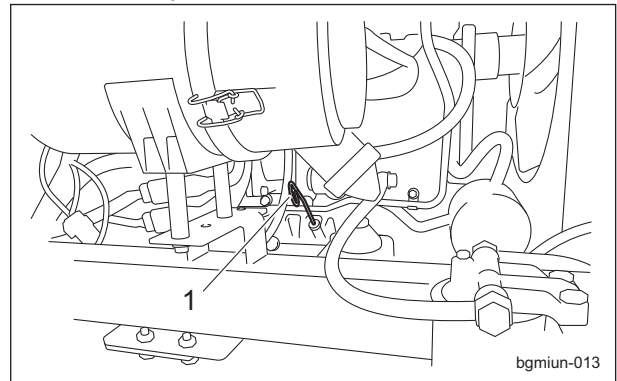

Inspection of Engine Oil_001

1	Oil gauge
---	-----------

3. The appropriate oil level should be between the upper and lower limit lines on the gauge.

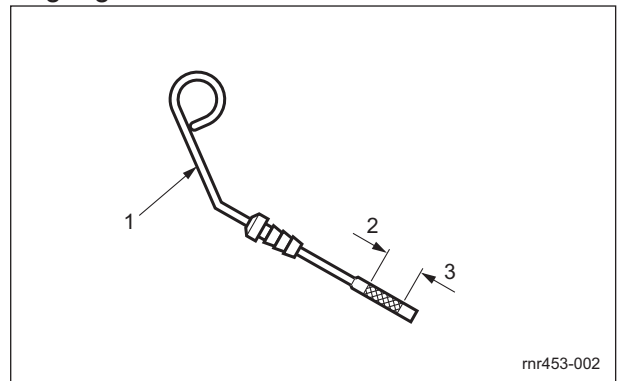

Inspection of Engine Oil_002

1	Oil level gauge
2	Upper limit
3	Lower limit

Handling Instructions

Supply of Engine Oil

Important

Do not supply too much engine oil. Otherwise, the engine may be damaged.

Important

Do not mix different types of engine oil.

Important

Be sure to use engine oil that is classified as JASO DH-2 or API Service Grade CJ-4, with SAE viscosity that is appropriate for the operating environment (ambient temperature).

Important

Securely tighten the oil level gauge and oil filler cap.

1. If the engine oil level is lower than the lower limit line on the oil level gauge, supply engine oil through the oil filling port. Remove the oil filler cap, and then supply new engine oil until the oil reaches a level in between the upper and lower limit lines on the oil level gauge.
2. Replace the oil filler cap.

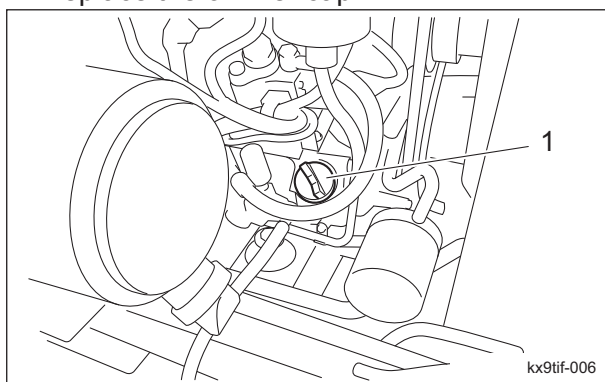

Supply of Engine Oil_001

1	Oil filler cap
---	----------------

3. It will take a while for the supplied engine oil to descend into the oil pan. Check the oil level again 10 to 20 minutes after supplying the oil.

Fuel

Inspection of Fuel Quantity

With the machine on a level surface, observe the fuel level in the monitor to check the fuel level.

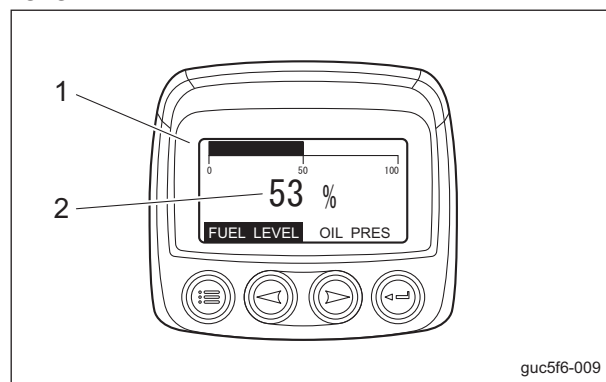

Inspection of Fuel Quantity_001

1	Monitor
2	Fuel level

Fuel Supply

Warning

Do not supply additional fuel after the fuel level indicates 100%.
If you supply too much fuel, it might overflow from the fuel cap when you travel or work on a slope.

Warning

Keep fire away while refueling.
Do not smoke.

Important

Use ultra-low sulfur diesel fuel (sulfur-free diesel fuel).

Important

In case of lack of fuel, DPF regeneration can not be performed.

If the monitor displays the warning message "FUEL LEVEL LOW", immediately stop operation, and then supply fuel (diesel). The fuel tank capacity is approximately 51.0 dm³ (51.0 L).

Handling Instructions

Note:

The factory default low fuel level is 10%. The level can be changed optionally.

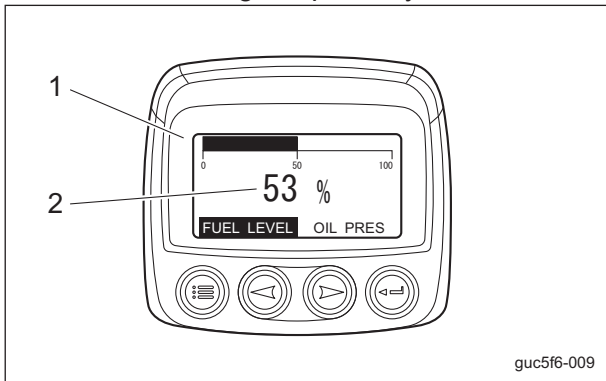

Fuel Supply_001

1	Monitor
2	Fuel level

Air Bleeding of Fuel System

1. Open the hood.
2. Set the key switch to the "ON" position and then start the electromagnetic pump.
3. A priming pump is installed on the feed pump.
Repeatedly press the top of the priming pump with your finger until resistance is felt, to bleed air.
4. Set the key switch to the "OFF" position.
5. Close the hood.

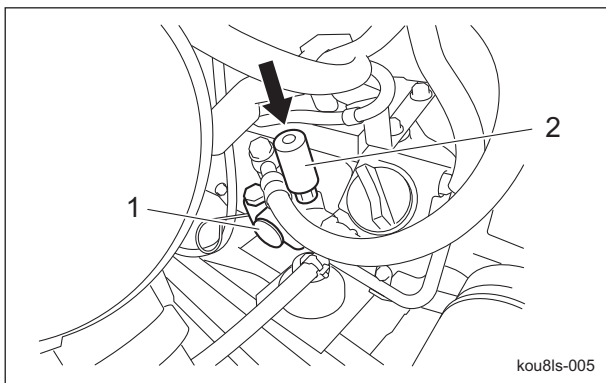

Air Bleeding of Fuel System_001

1	Feed pump
2	Priming pump

Water Separator

Inspection of Water Separator

Important

If water contaminates the fuel, the supply pump and injector may seize.

The water separator removes water from the fuel.

1. Make sure that debris and water have not accumulated in the cup.
With the float raised, water incorporation is confirmed.

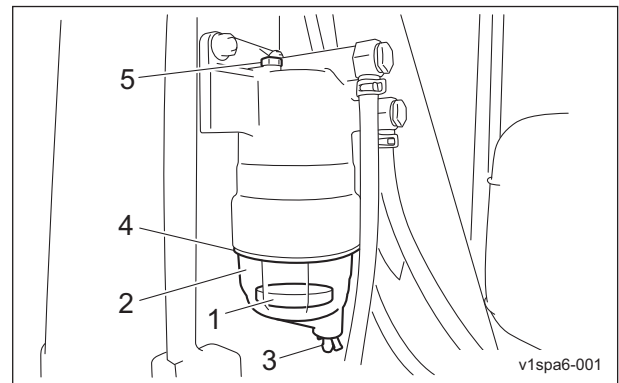

Inspection of Water Separator_001

1	Float
2	Cup
3	Water drain plug
4	Element
5	Air-bleeding bolt

Draining of Water Separator

For details on handling the engine, please refer to the Engine's Owner's Manual.

Important

If water contaminates the fuel, the supply pump and injector may be burnt out.

Drain the water at least every 50 hours and whenever the float is raised by water.

1. Follow the steps below to drain the water.
 - [1] Stop the engine, and then turn the key switch to the "OFF" position.
 - [2] Place a container under the water separator.
 - [3] Loosen the water drain plug and air-bleeding bolt to drain the water into the container.

Handling Instructions

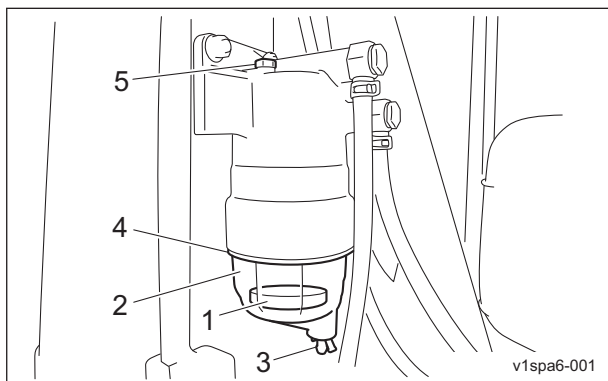

Draining of Water Separator_001

1	Float
2	Cup
3	Water drain plug
4	Element
5	Air-bleeding bolt

- [4] Tighten the water drain plug and air-bleeding bolt.
- [5] Bleed air from the fuel system.

Cleaning of Water Separator

For details on handling the engine, please refer to the Engine's Owner's Manual.

Important

If water contaminates the fuel, the supply pump and injector may be burnt out.

Clean the water separator at least every 500 hours and whenever debris has accumulated in the cup.

1. Follow the steps below to clean the water separator.
 - [1] Stop the engine, and then turn the key switch to the "OFF" position.
 - [2] Place a container under the water separator.
 - [3] Remove and clean the cup, element and float.
Replace the element with a new one when replacement needed.

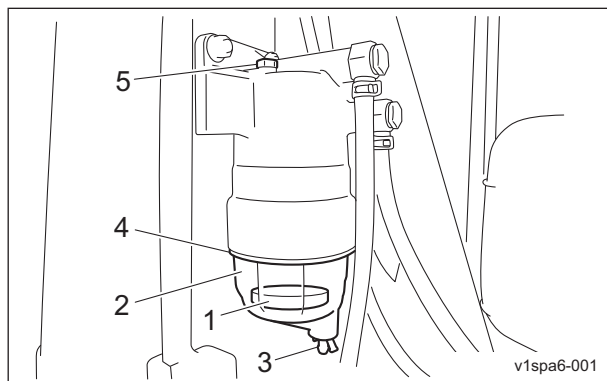

Cleaning of Water Separator_001

1	Float
2	Cup
3	Water drain plug
4	Element
5	Air-bleeding bolt

- [4] Install the cup, element and float in their original positions.
- [5] Bleed air from the fuel system.

Fuel Filter

Inspection of Fuel Filter

The fuel filter is positioned between the fuel strainer and the engine, and cleans the fuel flowing into the carburetor. When the fuel flow becomes insufficient, replace the fuel filter if necessary.

1. Make sure that there is no fuel leakage.
2. Make sure that the fuel filter is not damaged or dirty.

Oil Leakage

Inspection of Oil Leakage

Caution

When performing maintenance on the hydraulic system, lower the mower units.

After approximately 50 hours of operation, some tightened portions may be loosened and oil and grease may leak. Be sure to retighten the parts. Check the bottom of the machine for oil and grease leakage.

Handling Instructions

Tightening Torques

Important

Refer to the Tightening Torque table.
Note that the Baroness product warranty may not apply to defects caused by incorrect or overtorque tightening, etc.

Standard Tightening Torques

Bolts and Nuts

Important

A number of bolts are used in each part of this machine.
Be sure to re-tighten the bolts and nuts, because they may be loosened at the earlier stage of the use.

As to the bolts and nuts without any special instruction, tighten them in appropriate tightening torque with proper tool.

Too much tightening may cause the looseness or damage of the screw.

The strength of tightening is determined by types of screws, strength, the friction of thread face or base face and others.

The table below is for the galvanized or parkerized bolts.

In case that the strength of internal thread is weak, it is not applied.

Do not use rusty or sand attached "screw."

Otherwise, it may cause insufficient tightening even if you apply the specified tightening torque.

The friction of the screw face becomes higher and the tightening torque is canceled out by the friction, therefore sufficient tightening cannot be applied.

If "screw" is wet by water or oil, do not tighten it with normal tightening torque.

If the screw is wet, the torque coefficient will get smaller and it may result in too much tightening.

Too much tightening may cause looseness by the screw stretched or result in damage.



Do not use a bolt experienced too much burden.

Using the impact wrench requires the skill.

Do exercise as much as possible for steady tightening.

Handling Instructions

Nominal diameter	General bolt		
	Strength classification 4.8		
	 tib3yb-001		
	N-m	kgf-cm	lb-in
M5	3 - 5	30.59 - 50.99	26.55 - 44.26
M6	7 - 9	71.38 - 91.77	61.96 - 79.66
M8	14 - 19	142.76 - 193.74	123.91 - 168.17
M10	29 - 38	295.71 - 387.49	256.68 - 336.34
M12	52 - 67	530.24 - 683.20	460.25 - 593.02
M14	70 - 94	713.79 - 958.52	619.57 - 831.99
M16	88 - 112	897.34 - 1142.06	778.89 - 991.31
M18	116 - 144	1,182.85 - 1,468.37	1,026.72 - 1,274.54
M20	147 - 183	1,498.96 - 1,866.05	1,301.10 - 1,619.73
M22	295	3,008.12	2,611.05
M24	370	3,772.89	3,274.87
M27	550	5,608.35	4,868.05
M30	740	7,545.78	6,549.74

Nominal diameter	Heat-treated bolt					
	Strength classification 8.8			Strength classification 10.9		
	 tib3yb-002			 tib3yb-003		
	N-m	kgf-cm	lb-in	N-m	kgf-cm	lb-in
M5	5 - 7	50.99 - 71.38	44.26 - 61.96	7 - 10	71.38 - 101.97	61.96 - 88.51
M6	8 - 11	81.58 - 112.17	70.81 - 97.36	14 - 18	142.76 - 183.55	123.91 - 159.32
M8	23 - 29	234.53 - 295.71	203.57 - 256.68	28 - 38	285.52 - 387.49	247.83 - 336.34
M10	45 - 57	458.87 - 581.23	398.30 - 504.51	58 - 76	591.43 - 774.97	513.36 - 672.68
M12	67 - 85	683.20 - 866.75	593.02 - 752.34	104 - 134	1,060.49 - 1,366.40	920.50 - 1186.03
M14	106 - 134	1,080.88 - 1,366.40	938.21 - 1,186.03	140 - 188	1,427.58 - 1,917.04	1,239.14 - 1,663.99
M16	152 - 188	1,549.94 - 1,917.04	1,345.35 - 1,663.99	210 - 260	2,141.37 - 2,651.22	1,858.71 - 2,301.26
M18	200 - 240	2,039.40 - 2,447.28	1,770.20 - 2,124.24	280 - 340	2,855.16 - 3,466.98	2,478.28 - 3,009.34
M20	245 - 295	2,498.27 - 3,008.12	2,168.50 - 2,611.05	370 - 450	3,772.89 - 4,588.65	3,274.87 - 3,982.95
M22	-	-	-	530	5,404.41	4,691.03
M24	-	-	-	670	6,831.99	5,930.17
M27	-	-	-	1,000	10,197.00	8,851.00
M30	-	-	-	1,340	14,628.78	11,860.34

Note:

The same values are applied to "fine screw thread."

Handling Instructions

Principal Tightening Torques

Tightening Torque by Model

LM3210A

Tighten the following bolts and nuts at the torque specified in the table.

For thread locking adhesive, apply a middle strength thread locker (ThreeBond 1322 or equivalent anaerobic sealant).

Location	Code	Part name	Tightening torque			Thread locking adhesive	
			N-m	kgf-cm	lb-in		
Front wheel	Motor housing	K0014160402	Bolt, heat-treated M16-40P1.5	152 - 188	1549.94 - 1917.04	1345.35 - 1663.99	—
	Motor	K0013140502	Bolt, heat-treated M14-50	100	1019.7	885.1	—
	Wheel mounting base	1 1/4-18UNF	Slotted nut (Hydraulic motor)	400 - 430	4078.80 - 4384.71	3540.40 - 3805.93	—
	Disc brake	K001A080401	Bolt, w/hexagon hole, M8-40	28 - 38	285.52 - 387.49	247.83 - 336.34	—
	Wheel	K0014120652	Bolt, heat-treated M12-65P1.5	67 - 85	683.20 - 833.75	593.02 - 752.34	—
Rear wheel	Wheel mounting base	K0138240002	24 slotted nut high P1.5	180 - 200	1835.46 - 2039.40	1593.18 - 1770.20	—
	Wheel	K0014120652	Bolt, heat-treated M12-65P1.5	67 - 85	683.20 - 866.75	593.02 - 752.34	—
Front axle	K0015200702	Bolt, heat-treated M20-70P1.5	370 - 450	3772.89 - 4588.65	3274.87 - 3982.95	—	
Brake ass'y	K1720000190	Bolt, heat-treated M12P1.75	150 ± 15	1529.55 ± 152.96	1327.65 ± 132.77	○	
Engine	K0012120352	Bolt, heat-treated M12-35P1.25	67 - 85	683.20 - 886.75	593.02 - 752.34	—	
	K0015120552	Bolt, heat-treated M12-55P1.25	67 - 85	683.20 - 886.75	593.02 - 752.34	—	
	K0011100502	Bolt, heat-treated M10-50P1.25	58 - 76	591.43 - 774.97	513.36 - 672.68	—	
	K0013121102	Bolt, heat-treated M12-110	67 - 85	683.20 - 886.75	593.02 - 752.34	—	
	K3680000030	M3.5 Screw (accessories)	0.78 - 1.18	7.95 - 12.03	6.90 - 10.44	—	
Flywheel adapter	K0011100302	Bolt, heat-treated M10-30P1.25	58 - 76	591.43 - 774.97	513.36 - 672.68	—	
	K0010100352	Bolt, heat-treated M10-35	45 - 76	458.87 - 774.97	398.30 - 672.68	—	
Joint	K001A100401	Bolt, w/hexagon hole, M10-40	80	815.76	708.08	—	
	K0013100352	Bolt, heat-treated M10-35	45 - 76	458.87 - 774.97	398.30 - 672.68	—	
Kingpin stopper	K0010120502	Bolt, heat-treated M12-50	52 - 67	530.24 - 683.20	460.25 - 593.02	—	

Handling Instructions

Location	Code	Part name	Tightening torque			Thread locking adhesive
			N-m	kgf-cm	lb-in	
Tie rod	K161000020	Slotted nut of tie rod end RH	45	458.87	398.30	—
	K161100020	Slotted nut of tie rod end LH	45	458.87	398.30	—
Piston pump	K0013120502	Bolt, heat-treated M12-50	67 - 134	683.20 - 1366.40	593.02 - 1186.03	—
Tandem gear pump	K0069000251	Bolt, 3/8-16 UNC 31.8	29 - 38	295.71 - 387.49	256.68 - 336.34	—
Diff-lock valve	K001A100151	Bolt, w/hexagon hole, M10-15	29 - 38	295.71 - 387.49	256.68 - 336.34	—
Bumper	K0010120302	Bolt, heat-treated M12-30	67 - 134	683.20 - 1366.40	593.02 - 1186.03	—
Cover mounting bracket	K0000080202	Bolt, M8-20	9 - 14	91.77 - 142.76	61.96 - 123.91	—
Bed knife (bottom blade)	K0071001182	Screw, heat-treated flathead M10-16	29 - 38	295.71 - 387.49	256.68 - 336.34	—
Mower stopper	K0041060122	Screw, + flathead M6-12	—	—	—	○
ROPS	K0013121102	Bolt, HT M12-110	104 - 134	1,060.49 - 1,366.40	920.50 - 1186.03	—

Handling Instructions

Adjustment before Work

Adjustment of Steering Wheel

Warning

Since it is dangerous, do not adjust the steering wheel while traveling.

Caution

Be sure the steering wheel position is securely locked. It may result in an unexpected accident if it becomes loose while traveling.

The steering wheel can be adjusted up or down. Adjust the position according to the operator's body size. Shift the tilt lever to the "FREE" position, move the steering wheel to the position that suits your work requirements, and then shift the tilt lever to the "LOCK" position to secure the steering wheel in place. The tilt lever is located in the right front of the driver's position.

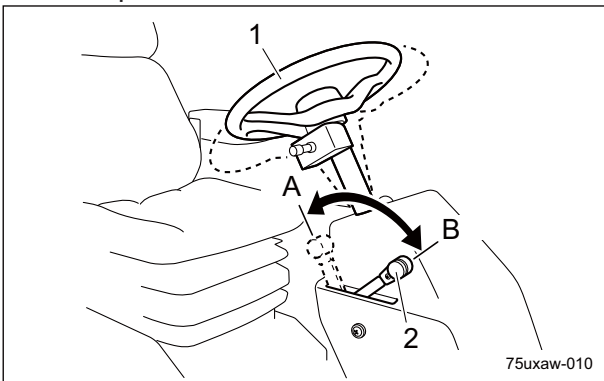

Adjustment of Steering Wheel_001

1	Steering wheel
2	Tilt lever
A	FREE (released)
B	LOCK (locked)

- Turn the suspension adjustment handle to adjust the firmness of the seat suspension. Refer to the suspension indicator while making adjustments. [45 to 130 kg (99.2 to 286.6 lb)]
- Turn the armrest adjustment knob to adjust the angle of the armrests.
- Turn the seat height adjustment knob to adjust the height of the seat steplessly. [0 to 60 mm (0 to 2.36 in)]
Adjust the height of the seat while sitting in it.

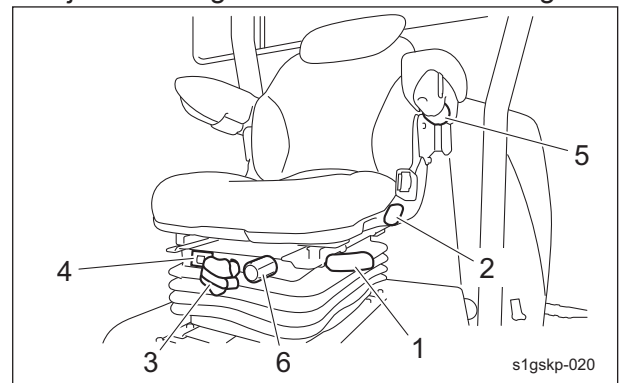

Adjustment of Seat_001

1	Forward/backward adjustment lever
2	Tilt adjustment lever
3	Suspension adjustment handle
4	Suspension indicator
5	Armrest adjustment knob
6	Seat height adjustment knob

Adjustment of Seat

Use the adjustment levers to adjust the seat. Adjust the position to fit the operator.

- Use the forward/backward adjustment lever to adjust the seat back and forth.
- Use the tilt adjustment lever to adjust the angle of the backrest.

Handling Instructions

Adjustment of Blade Engagement

⚠ Caution

When handling the reel cutter (cutting cylinder) and the bed knife (bottom blade), wear gloves to protect your hands. Pay attention not to let the reel cutter (cutting cylinder) catch your gloves. Otherwise, you may injure your hand or fingers.

1. Stop the engine.
2. Set the reel rotation/stop switching lever to the "Stop" position.

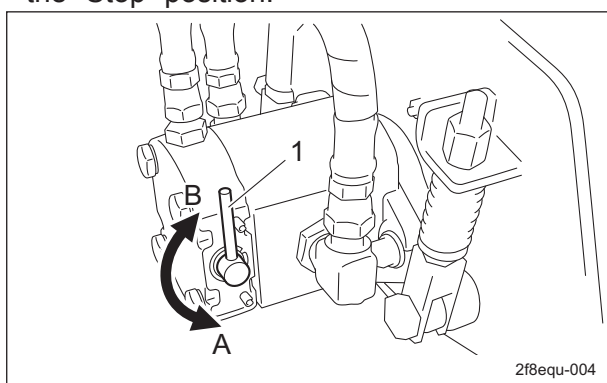

Adjustment of Blade Engagement_001

1	Reel rotation/stop switching lever
A	Stop
B	Rotate

3. With the cutter adjustment nut, adjust the engagement between the reel cutter (cutting cylinder) and the bed knife (bottom blade) so that newspaper (two to three sheets) will be cut by the edge of both blades when the blades in their entirety come slightly into contact with each other.

4. Insert two or three strips of newspaper into the space between the reel cutter (cutting cylinder) and the bed knife (bottom blade) at an angle of 90 degrees. Then, rotate the reel cutter (cutting cylinder) counter-clockwise (when you face the mower unit from the left) to check the sharpness of the blades. Check the sharpness of the entire range (three or four points) of the reel cutter (cutting cylinder).

- If a gap is created between edges:
Loosen the cutter adjustment nut to apply more contact pressure between the reel cutter (cutting cylinder) and the bed knife (bottom blade).

- If the reel cutter (cutting cylinder) is too tight to turn:
Tighten the cutter adjustment nut to reduce the contact pressure between the reel cutter (cutting cylinder) and the bed knife (bottom blade).
- If the blades still cannot cut well:
Perform back lapping of the reel cutter (cutting cylinder).

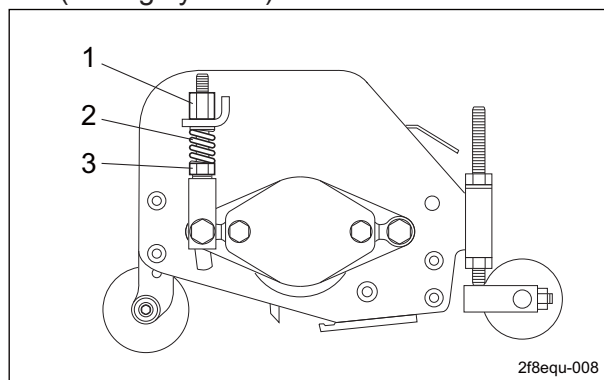

Adjustment of Blade Engagement_002

1	Cutter adjustment nut
2	Spring
3	Pipe with cutter adjusting screw

Adjustment of Cutting Height

Roller (Roller Type)

Adjust the cutting height to fit your cutting work.

You can adjust the front roller in four stages.

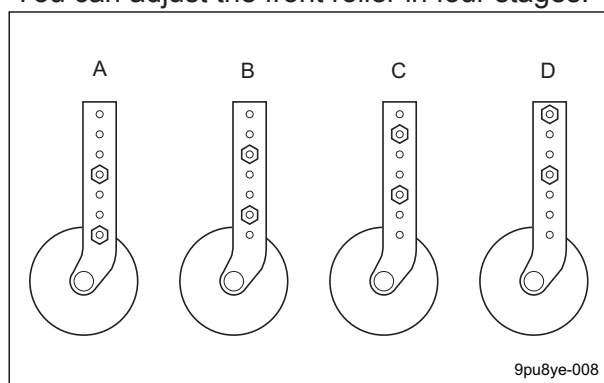

Roller (Roller Type)_001

A	10 - 20 mm (0.39 - 0.79 in)
B	20 - 30 mm (0.79 - 1.81 in)
C	28 - 40 mm (1.10 - 1.57 in)
D	38 - 60 mm (1.50 - 2.36 in)

Handling Instructions

Attach the front roller in a position within the range of cutting height that suits your work requirements.

1. To increase cutting height:
 - [1] Loosen cutting height adjustment nut A, tighten cutting height adjustment nut B, then lower the rear roller.
 - [2] Use the cutting height gauge to determine the position, then tighten cutting height adjustment nut A securely.
2. To decrease cutting height:
 - [1] Loosen cutting height adjustment nut B, tighten cutting height adjustment nut A, then raise the rear roller.
 - [2] Use the cutting height gauge to determine the position, then tighten cutting height adjustment nut B securely.

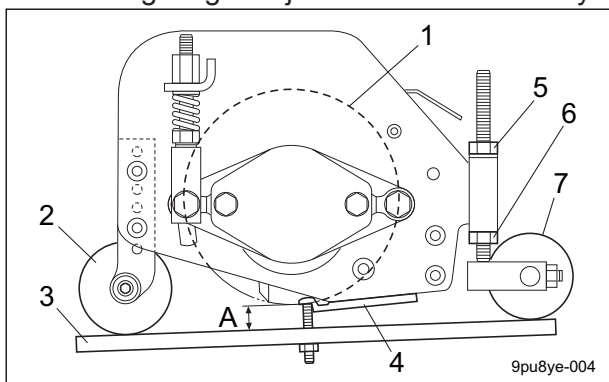

Roller (Roller Type)_002

1	Reel cutter (cutting cylinder)
2	Front roller
3	Cutting height gauge
4	Bed knife (Bottom blade)
5	Cutting height adjustment nut A
6	Cutting height adjustment nut B
7	Rear roller
A	Cutting height

Front Wheel Type

Adjust the cutting height to fit your cutting work.

You can adjust the wheel to one of four levels.

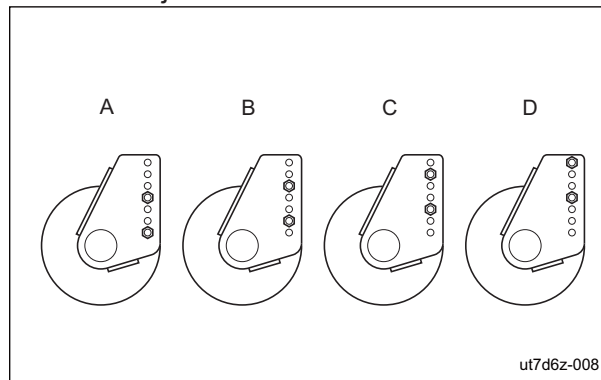

Front Wheel Type_001

A	17 - 32 mm (0.67 - 1.26 in)
B	23 - 37 mm (0.91 - 1.46 in)
C	29 - 43 mm (1.14 - 1.69 in)
D	35 - 68 mm (1.38 - 2.68 in)

Attach the wheel in a position within the range of cutting height that suits your work requirements.

1. To increase cutting height:
 - [1] Loosen cutting height adjustment nut A, tighten cutting height adjustment nut B, then lower the rear roller.
 - [2] Use the cutting height gauge to determine the position, then tighten cutting height adjustment nut A securely.
2. To decrease cutting height:
 - [1] Loosen cutting height adjustment nut B, tighten cutting height adjustment nut A, then raise the rear roller.
 - [2] Use the cutting height gauge to determine the position, then tighten cutting height adjustment nut B securely.

Handling Instructions

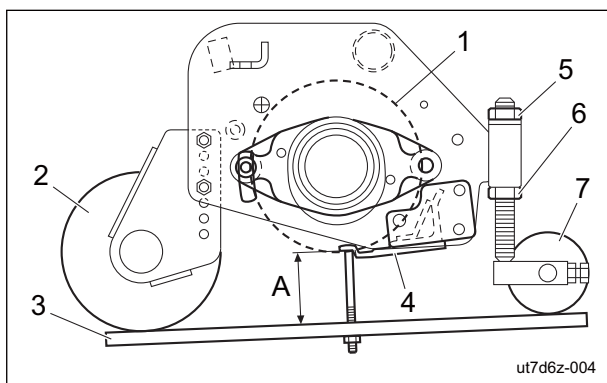

Front Wheel Type_002

1	Reel cutter (cutting cylinder)
2	Front Wheel
3	Cutting height gauge
4	Bed knife (bottom blade)
5	Cutting height adjustment nut A
6	Cutting height adjustment nut B
7	Rear roller
A	Cutting height

Adjustment of Cutter Adjustment Spring

If the diameter of the reel cutter (cutting cylinder) becomes smaller, adjust the cutter adjustment spring.

1. Adjust the blade engagement.
2. Loosen the pipe with cutter adjusting screw, and then adjust the length of the spring coil to approximately 40 mm (1.575 in.).

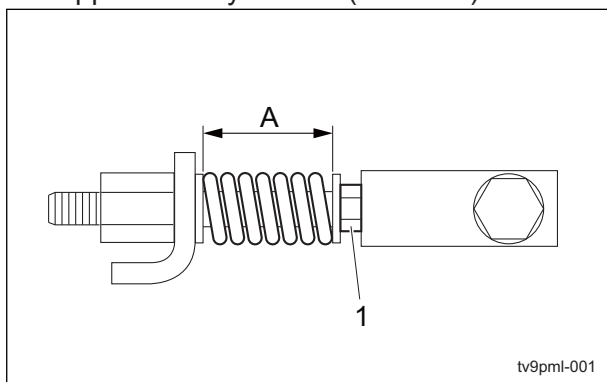

Adjustment of Cutter Adjustment Spring_001

1	Pipe with cutter adjusting screw
A	40 mm (1.575 in.)

Adjustment of Reel Cover

Note:

Depending on the specifications, this function may not be available.

The angle of the reel cover can be adjusted.

1. Pull the right and left knobs securing the reel cover to release it.

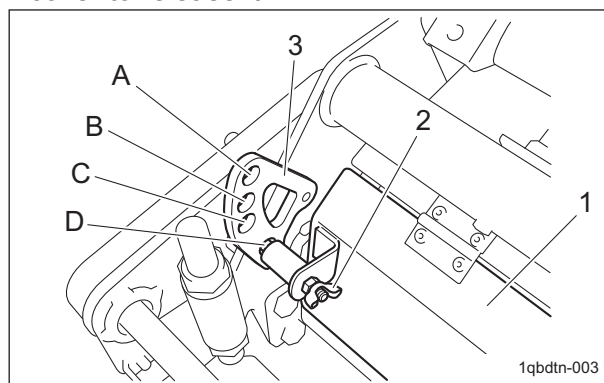

Adjustment of Reel Cover_001

1	Reel cover
2	Knob
3	Cover adjustment plate
A	Fully open
B	15 degrees closed
C	30 degrees closed
D	Fully closed

2. Select the hold position of the cover adjustment plate and secure the reel cover.

Handling Instructions

Adjustment of CR Brush

Note:
Depending on the specifications, this function may not be available.

Important

Pressing the brush against the roller too tightly will cause the belt to slip or break.

Important

CR brush prevents clippings etc. from adherence to the rear roller owing to rotating brush.

1. Loosen the bolts and nuts attached to the both ends of CR brush.

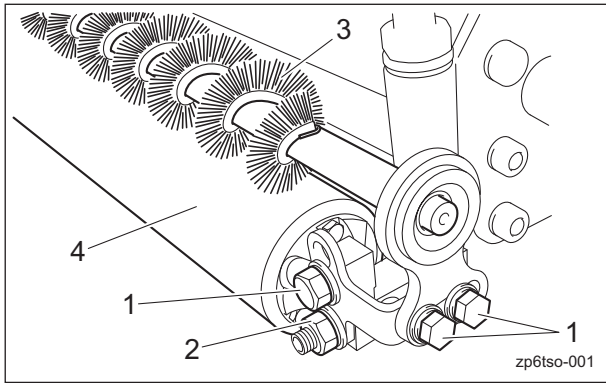

Adjustment of CR Brush_001

1	Bolts
2	Nuts
3	Brush
4	Rear roller

2. Securely tighten the loosened bolts and nuts as the gap between the brush and rear roller is adjusted to between 0 and 1.0 mm (0 - 0.039 in).

Procedure to Start/Stop Engine

Start/Stop of Engine

Procedure to Start Engine

Caution

When starting the engine, the reel cutter (cutting cylinder) may rotate slowly. Before starting the engine, make sure that there are no other people or obstacles around the machine.

Important

When restarting the engine after it has been turned off, wait until the electromagnetic pump has fully stopped before restarting the engine. The electromagnetic pump will stop approximately 7 seconds after the key switch is turned to the "OFF" position.

Important

Starter operation must take 15 seconds or less. If the engine does not start, stop using the battery for 30 to 60 seconds to avoid exhausting the battery.

1. Sit on the seat.
2. Make sure that the parking brake is applied.
3. Make sure that the knife rotation switch is in the "STOP" position.
4. Make sure that the traveling pedal is in the neutral position.
5. Move the throttle knob halfway from the "Low speed" position toward the "High speed" position.
6. Switch the ignition key to the "ON (GLOW)" position.

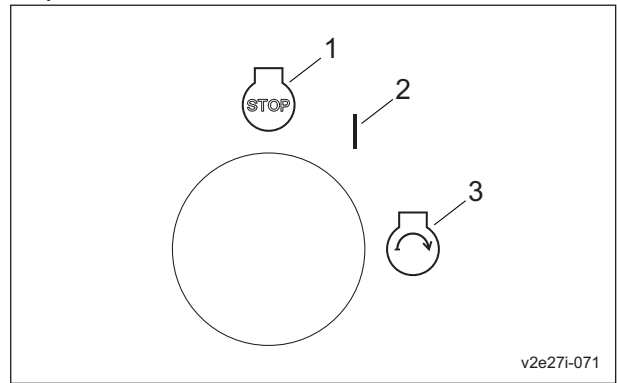

Procedure to Start Engine_001

1	OFF
2	ON (GLOW)
3	START

Handling Instructions

Important

When the ignition key is switched to the "ON" position, "Warming up" may appear in the monitor display.

Do not start the engine until the message disappears.

7. Make sure that the glow plug is generating heat, the "BARONESS" logo or "Warming up" message appears in the monitor display, and the yellow and red LEDs are lit.

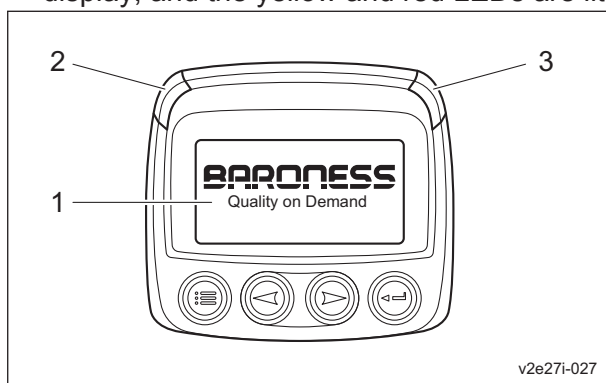

Procedure to Start Engine_002

1	Monitor display
2	Yellow LED
3	Red LED

Important

Quickly returning the ignition key from the "START" position to the "ON" position may result in damage to the machine.

8. After the "BARONESS" logo and the yellow and red LEDs go off and the parameters (items and values such as the rotation speed) appear, immediately set the ignition key to the "START" position.
9. When the starter starts rotating and the engine starts, slowly return the ignition key to the "ON" position.
10. Move the throttle knob to the "Low speed" position, and then warm up the engine for 1-2 minutes.
11. Gradually move the throttle knob toward the "High speed" position.

Procedure to Stop Engine

1. Set the traveling pedal to the neutral position.
2. Apply the parking brake.
3. Set the reel rotation switch to the "Stop" position.
4. Shift the throttle lever to the "Low speed" position, and then idle the machine for 1-2 minutes.
5. Switch the ignition key to the "OFF" position.
6. Make sure that the engine has stopped.
7. Remove the ignition key.
8. Leave the driver's seat.

Safety Mechanisms

This machine features a safety device for starting/stopping the engine.

1. As for starting the engine, the safety device prevents the engine from starting unless it meets each of the following four conditions.
 - An operator is sitting on the seat.
 - The parking brake is applied.
 - The reel rotation switch is set to the "OFF" position.
 - The traveling pedal is set to the neutral position.

Important

When you restart the engine after the safety device stops the engine, be sure to return the ignition key to the "OFF" position first, and then restart it.

Otherwise the engine does not start.

2. In the event the operator leaves the seat with the parking brake applied and the engine running, the safety device will be activated and will stop the engine under any of the following conditions:
 - The traveling pedal is not set to the neutral position. (The operator has depressed the traveling pedal.)
 - The reel rotation switch is set to the "Rotate" position.

However, when the reel reverse switch is set to the "ON" position (reverse rotation), the engine does not stop.

Handling Instructions

Warning Mechanisms

Important

When the buzzer (intermittent tone) sounds, be sure to stop operation since the engine is overheated.

Do not stop the engine without idling. Allow the engine to cool down, first. Keep the engine idling for about 5 minutes before stopping. Remove dust that is jamming in the radiator, air cleaner, and etc.

This machine features warning mechanisms for overheating, the hydraulic oil and the engine.

1. If the engine water temperature exceeds 115 degrees Celsius, a buzzer will sound. (intermittent tone)
2. If the oil level in the hydraulic tank declines from the specified level by approximately 2.0 dm³ (2.0 L), a buzzer will sound. (continuous tone)
3. With an engine malfunction, a monitor LED lights up and a fault code appears.

Operation Method

Cautions for when You Leave The Machine

⚠ Caution

If the brakes are not sufficiently effective, use the wheel stoppers to secure the machine.

⚠ Caution

Never park the machine on a slope.

Positions of Operation Decals

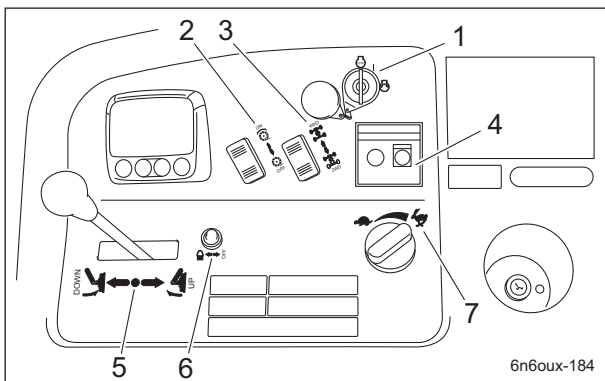

Positions of Operation Decals_001

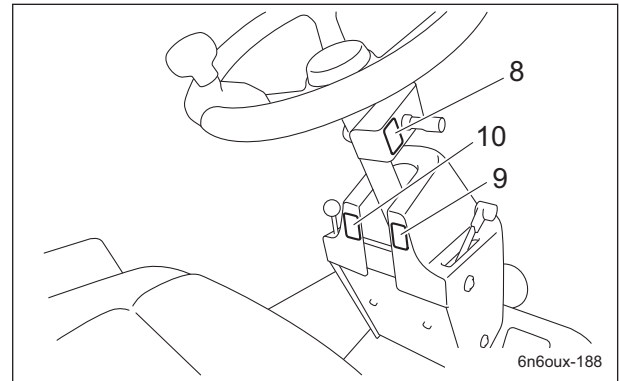

Positions of Operation Decals_002

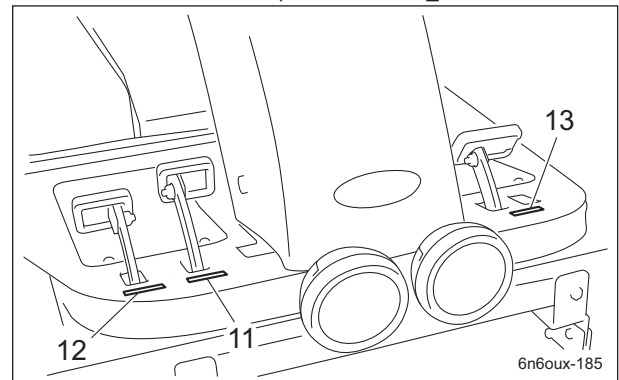

Positions of Operation Decals_003

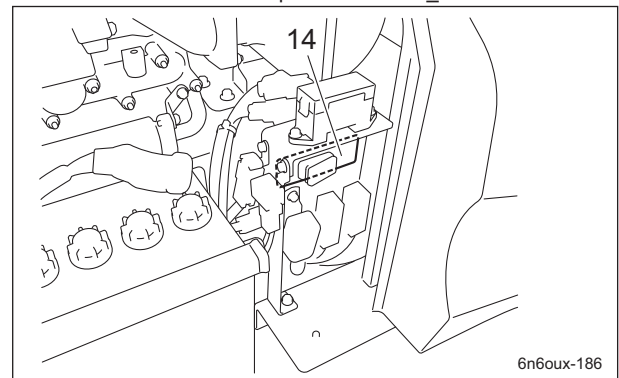

Positions of Operation Decals_004

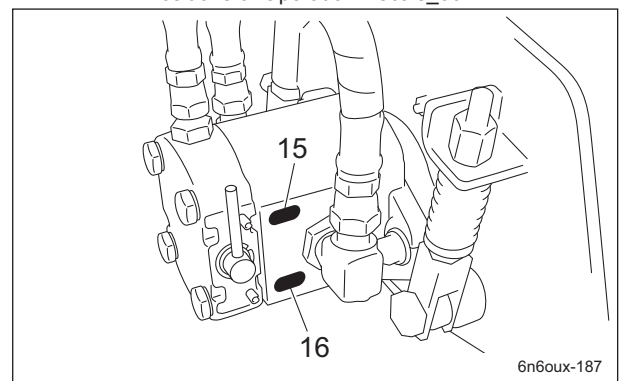

Positions of Operation Decals_005

Handling Instructions

1	Key switch decal
2	Reel rotation mark
3	2WD/4WD selector mark
4	DPF regeneration mark (EN)
5	Mower unit up/down decal
6	Light switch mark
7	Engine rotation mark
8	Differential lock decal
9	Tilt steering decal
10	Parking brake decal
11	FORWARD decal
12	BACKWARD decal
13	BRAKE decal
14	Lapping decal
15	Reel rotation decal
16	Reel stop decal

Description of Operation Decals

Key Switch Decal

Decal, key switch
This indicates the key switch positions.

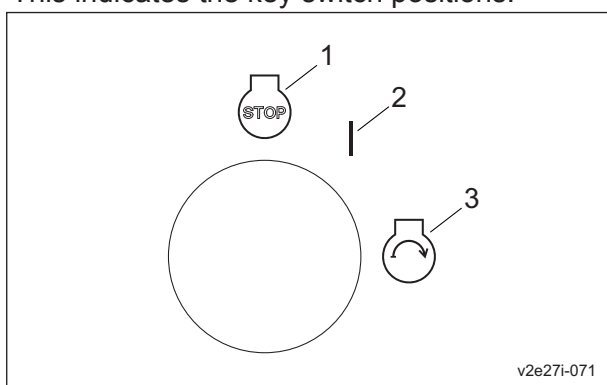

Key Switch Decal_001

1	OFF
2	ON (GLOW)
3	START

Reel Rotation Mark

Reel rotation mark
It illustrates Rotation/Stop of the reel cutter (cutting cylinder).

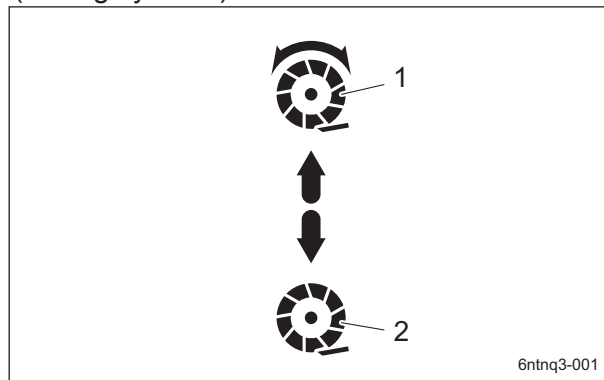

Reel Rotation Mark_001

1	Rotation
2	Stop

2WD/4WD Selector Mark

2WD/4WD selector mark
This indicates the 2WD/4WD positions.

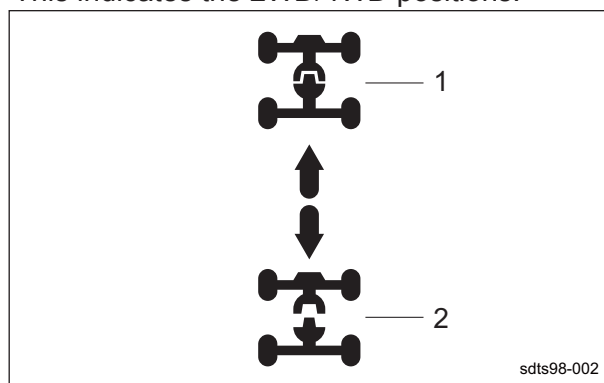

2WD/4WD Selector Mark_001

1	4WD
2	2WD

Handling Instructions

DPF Regeneration Mark (EN)

-
DPF regeneration mark (EN)
This indicates the changeover of DPF regeneration.

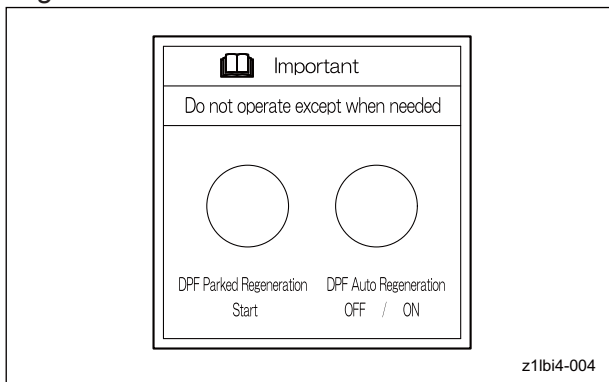

DPF Regeneration Mark (EN)_001

Light Switch Mark

Note:
Depending on the specifications, this function may not be available.
Light switch mark
It illustrates ON/OFF of the light.

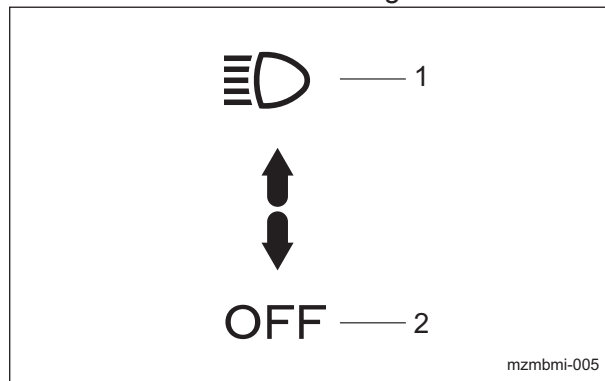

Light Switch Mark_001

1	ON
2	OFF

Mower Unit Up/Down Decal

Decal, mower unit up/down
This indicates the Up/Down positions of the mower unit.

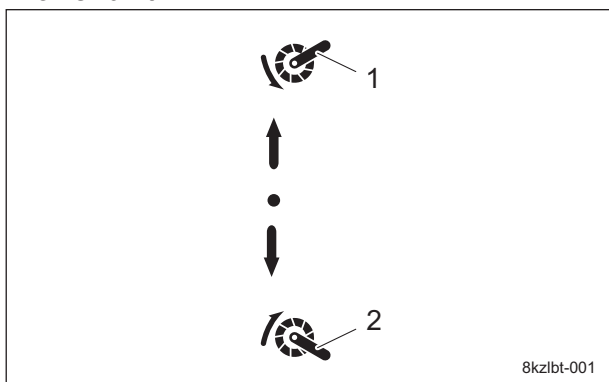

Mower Unit Up/Down Decal_001

1	Down
2	Up

Engine Rotation Mark

Engine rotation mark
This indicates low/high speed of engine rotation.

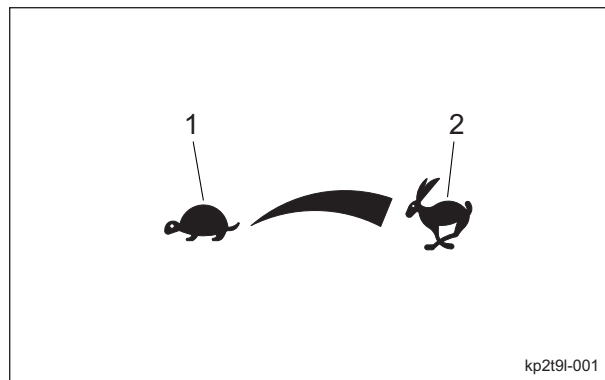

Engine Rotation Mark_001

1	Low speed
2	High speed

Handling Instructions

Differential Lock Decal

K4203001420
 Decal, differential lock
 This indicates the positions for engaging or releasing the differential lock.

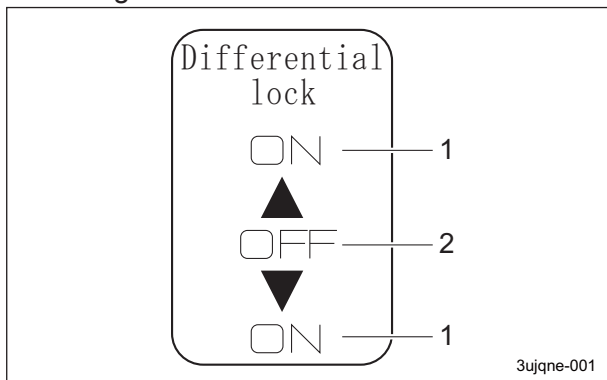

Differential Lock Decal_001

1	Engage
2	Release

Parking Brake Decal

K4203001340
 Parking brake decal
 This shows how to lock and release the parking brake.

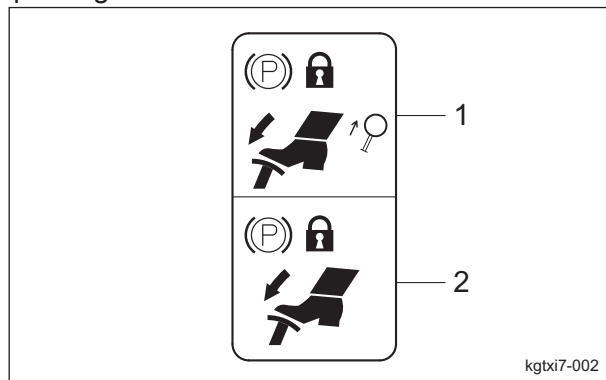

Parking Brake Decal_001

1	Lock
2	Release

Tilt Steering Decal

K4203001350
 Decal, tilt steering
 This illustrates the tilt directions of the steering wheel and the locked/free positions.

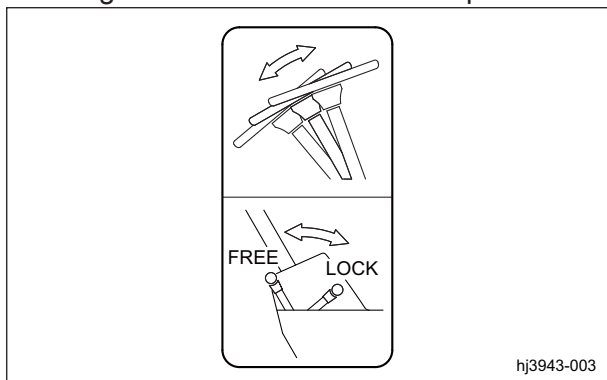

Tilt Steering Decal_001

FORWARD Decal

K4203001430
 Decal, FORWARD
 This indicates forward travel.



FORWARD Decal_001

Handling Instructions

BACKWARD Decal

K4203001440
 Decal, BACKWARD
 This indicates backward travel.



BACKWARD Decal_001

Lapping Decal

K4203001590
 Decal, lapping
 This indicates rotational direction of the reel cutter (cutting cylinder).

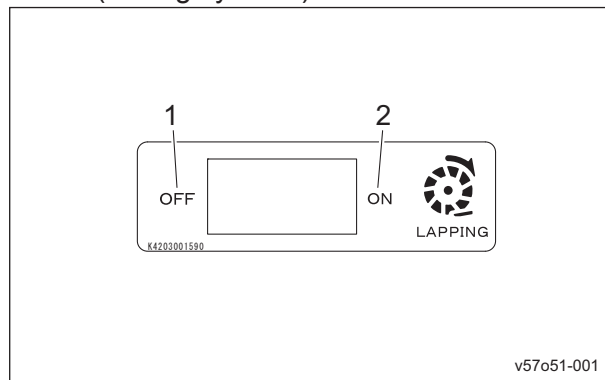

Lapping Decal_001

1	Normal rotation (cutting rotation)
2	Reverse rotation (back lapping rotation)

BRAKE Decal

K4203001450
 Decal, BRAKE
 This indicates brake.



BRAKE Decal_001

Reel Rotation Decal

K4203001300
 Decal, reel rotation
 This indicates rotation of the reel cutter (cutting cylinder).

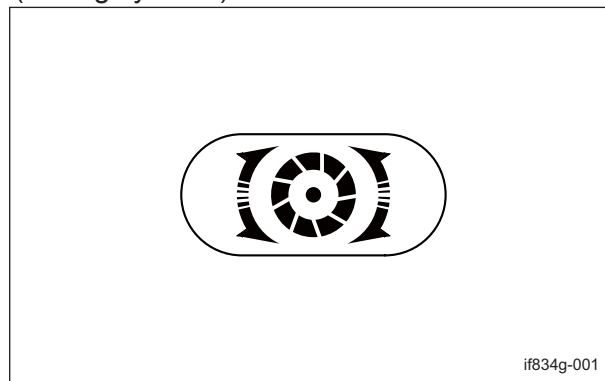

Reel Rotation Decal_001

Handling Instructions

Reel Stop Decal

K4203001310
Decal, reel stop
This indicates stop of the reel cutter (cutting cylinder).

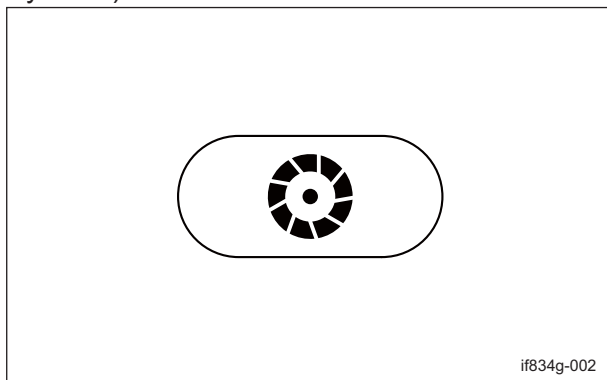

Reel Stop Decal_001

Proximity Sensors

There are three proximity sensors on mower arm fulcrums #3, #4 and #5. These sensors detect the raised or lowered positions of mower units #3, #4 and #5. The information is related to controlling rotation and stop of the reel cutters (cutting cylinders).

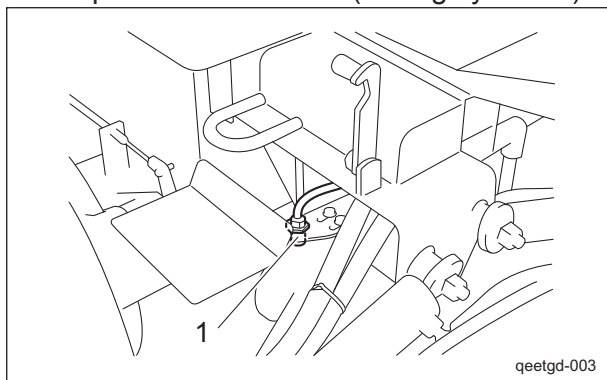

Proximity Sensors_001

1	Proximity sensor
---	------------------

Relays

The relay box is located inside the right tank cover. These relays control operation of the diff-lock, rotation of the reel cutters (cutting cylinders), and 2WD/4WD selection. The operating condition can be checked by the illumination of the LEDs.

- LEDs ① and ② light up when the diff-lock valve is in the "ON" position.
- LEDs ③ and ⑤ light up when the reel rotation switch is in the "Rotation" position and the mower units are lowered.
- LEDs ④ and ⑥ light up when the reel reverse switch is in the "Reverse" position and the mower units are lowered.
- LED ⑦ is not used.
- LED ⑧ lights up when the 2WD/4WD selector switch is in the "4WD" position, and then the machine enters 4WD.

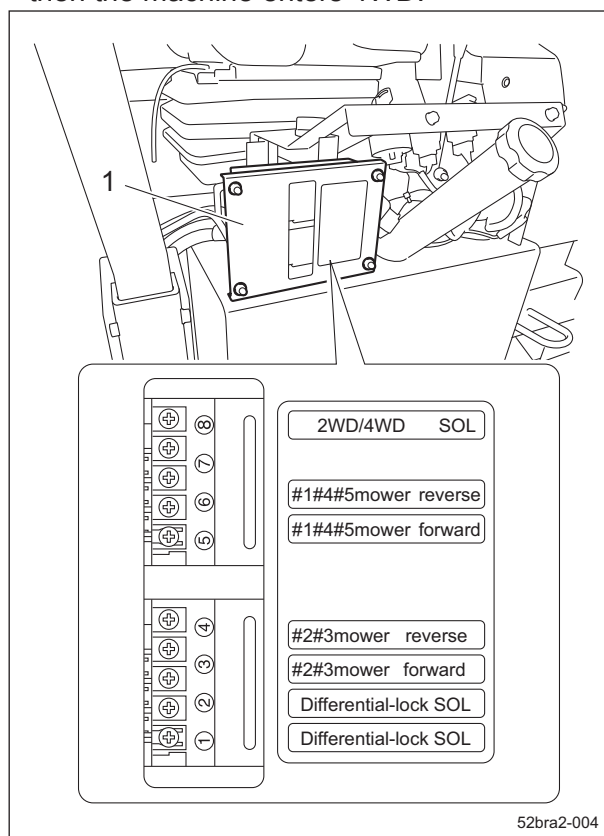

Relays_001

1	Relay box
---	-----------

Handling Instructions

Reel Rotation Switch

⚠ Caution

Set the reel rotation switch to the "Rotation" position immediately before starting cutting work. At all other times, be sure to leave the reel rotation switch set to the "Stop" position.

The reel rotation switch is located in the operation panel and operates rotation of the reel cutters (cutting cylinders) of the mower units.

When the reel rotation switch is set to the "Rotation" position, the reel cutters (cutting cylinders) of all mower units will rotate. When the reel rotation switch is set to the "Stop" position, the reel cutters (cutting cylinders) will stop.

Note:

When the mower units are raised, the reel cutters (cutting cylinders) do not rotate, even if the switch is set to the "Rotation" position.

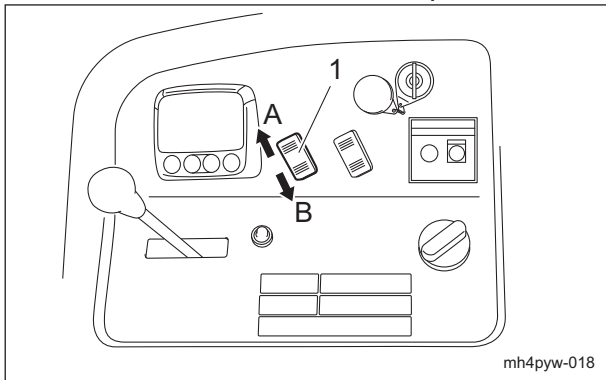

Reel Rotation Switch_001

1	Reel rotation switch
A	Rotation
B	Stop

2WD/4WD Selector Switch

⚠ Caution

When working on a slope, be sure to use the machine in 4WD.

⚠ Caution

When traveling, be sure to stop the rotation of the reel cutters (cutting cylinders) and raise the mower units.

The 2WD/4WD selector switch is located in the operation panel.

When the switch is set to the "2WD" position, the machine will be in two-wheel drive (front-wheel drive). When it is set to the "4WD" position, the machine will be in four-wheel drive.

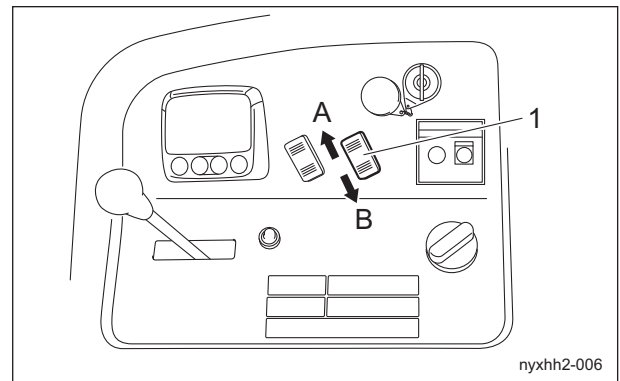

2WD/4WD Selector Switch_001

1	2WD/4WD selector switch
A	4WD
B	2WD

Handling Instructions

DPF Auto Regeneration Inhibit Switch

⚠ Caution

Normally, set the DPF auto regeneration inhibit switch to "Auto regeneration mode". However, when operating in a location where fires may occur, set the DPF auto regeneration inhibit switch to "Auto regeneration inhibit mode".

Important

The DPF auto regeneration inhibit switch is reset to "Auto regeneration mode" when the engine is started even if the engine was stopped with the DPF auto regeneration inhibit switch set to "Auto regeneration inhibit mode".

The DPF auto regeneration inhibit switch is located in the operation panel.

The DPF auto regeneration inhibit switch is the switch for shifting between "Auto regeneration mode" and "Auto regeneration inhibit mode". With the engine running, press this switch to shift between "Auto regeneration mode" and "Auto regeneration inhibit mode".

- Auto regeneration mode:
The DPF auto regeneration inhibit switch is reset to "Auto regeneration mode" when the engine is started.
In "Auto regeneration mode" regeneration is automatically performed regardless of the main vehicle's travel and stop on the condition that a specific amount of PM is accumulated and the requirements for DPF regeneration are fulfilled.
- Auto regeneration inhibit mode:
In order to set to "Auto regeneration inhibit mode", press the DPF auto regeneration inhibit switch after the engine is started.
In "Auto regeneration inhibit mode" PM accumulates in the DPF and PM accumulation level increases.
Unless the operator implements regeneration on his own will, regeneration is not performed.

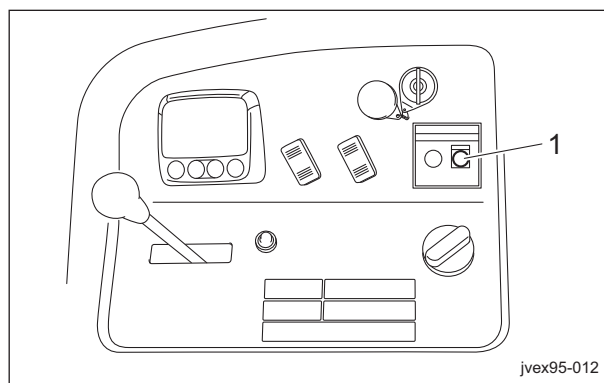

DPF Auto Regeneration Inhibit Switch_001

1 DPF auto regeneration inhibit switch

When the DPF auto regeneration inhibit switch is pressed and set to "Auto regeneration inhibit mode", the monitor displays Auto regeneration inhibit icon.

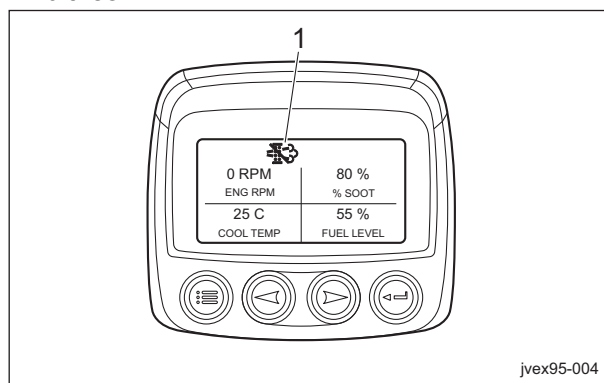

DPF Auto Regeneration Inhibit Switch_002

1 Auto regeneration inhibit icon

Handling Instructions

DPF Parked Regeneration Switch

Danger

Do not perform DPF regeneration in a location where fires may occur since it will become extremely hot around the exhaust outlet during DPF regeneration.

Important

If parked regeneration is not required, it will not start even if the switch is pressed.

The DPF parked regeneration switch is located in the operation panel.
 The DPF parked regeneration switch is the switch for actuating parked regeneration.
 When the regeneration icon is blinking, press the switch to start parked regeneration.

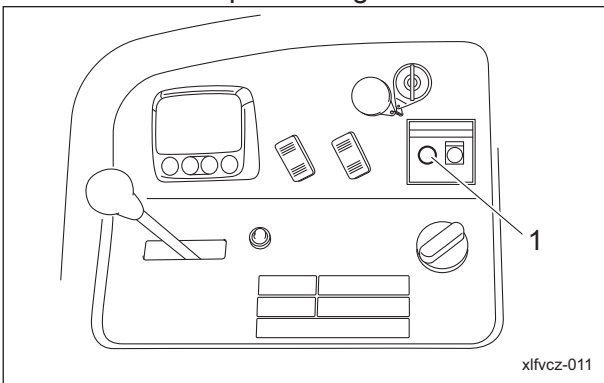

DPF Parked Regeneration Switch_001

1	DPF parked regeneration switch
---	--------------------------------

When parked regeneration starts, Regeneration icon in the monitor display changes from blinking to lighting.

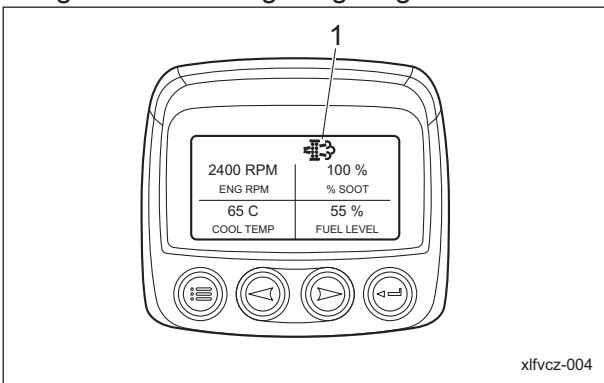

DPF Parked Regeneration Switch_002

1	Regeneration icon
---	-------------------

Light Switch

Note:

Depending on the specifications, this function may not be available.

Caution

The lights provide auxiliary lighting. Do not travel or operate the machine at night or under poor visibility.

The light switch is located in the operation panel.
 When the switch is set to the "ON" position, the lights turn on. When it is set to the "OFF" position, the lights turn off.

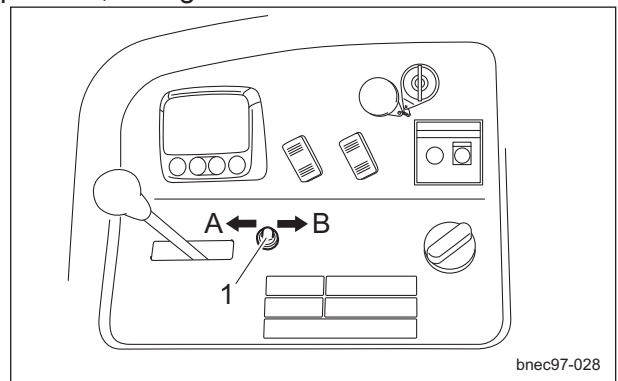

Light Switch_001

1	Light switch
A	ON (turn on)
B	OFF (turn off)

Handling Instructions

Reel Reverse Switch

Important

Do not switch the rotation directions, "Normal rotation" or "Reverse" while the reel cutter (cutting cylinder) is rotating. Otherwise, a hydraulic system malfunction may result.

Important

If the reel rotation switch is not set to the "Rotation" position, the reel cutter (cutting cylinder) will not rotate.

This is located under the hood.
 This switches the rotation direction of the reel cutter (cutting cylinder).
 When the reel reverse switch is set to the "Reverse" position, the reel cutters (cutting cylinders) of all mower units rotate in reverse (back lapping motion). When the reel reverse switch is set to the "Normal rotation" position, the reel cutters (cutting cylinders) rotate for cutting.

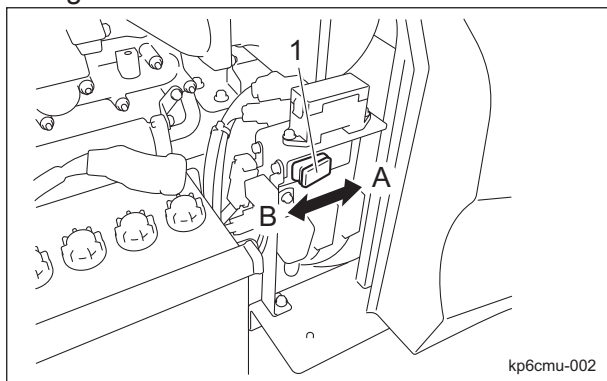

Reel Reverse Switch_001

1	Reel reverse switch
A	Reverse
B	Normal rotation

Reel Rotation/Stop Switching Lever

Caution

Before operating the reel rotation/stop switching lever, be sure to set the reel rotation switch to the "Stop" position.

The reel rotation/stop switching lever is located on the reel motor attached to each mower unit. It is used during cutting and back lapping. You must shift only the lever(s) for the mower unit(s) that you plan to use for cutting or back lapping to the "Rotate" position. Leave the lever(s) for other mower units in the "Stop" position.

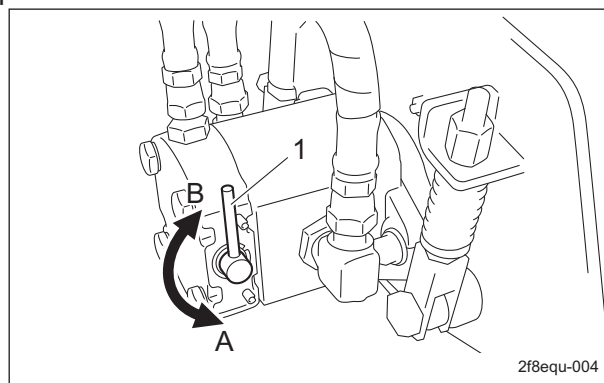

Reel Rotation/Stop Switching Lever_001

1	Reel rotation/stop switching lever
A	Stop
B	Rotate

Handling Instructions

Reel Rotation Adjustment Valve

These valves adjust the rotation speeds of the reel cutters (cutting cylinders).

For mower units #1, #4 and #5

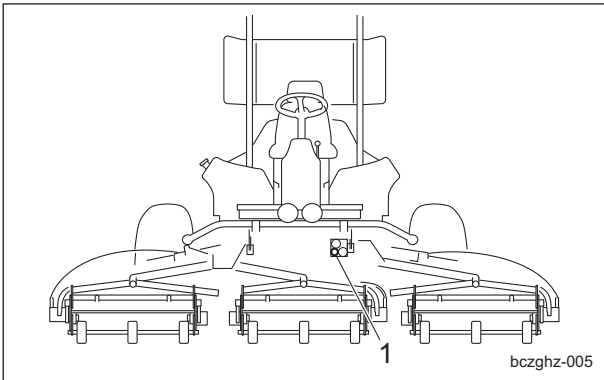

Reel Rotation Adjustment Valve_001

1	Valve for mowers #1 and #5
---	----------------------------

For mower units #2 and #3

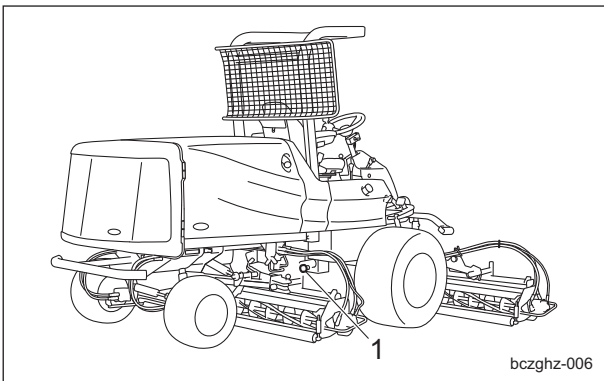

Reel Rotation Adjustment Valve_002

1	Valve for mowers #2, #3 and #4
---	--------------------------------

Reduce the rotation speed by loosening the lock nut, then tightening the knob. After making adjustments, tighten the lock nut.

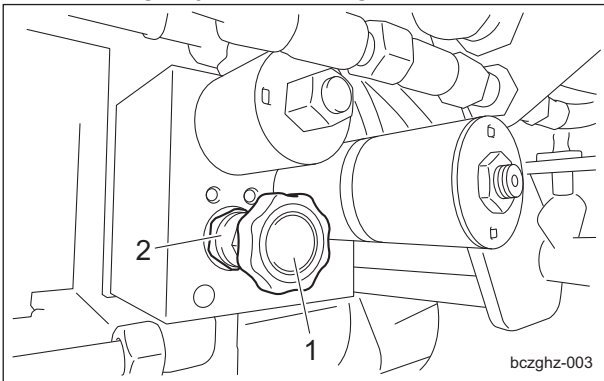

Reel Rotation Adjustment Valve_003

1	Knob
2	Lock nut

Mower Lock Lever (Latch)

The mower lock levers (latches) are located in the foot area on the left and right sides. Hook the mower lock levers (latches) on the arms to keep the mower units #4 and #5 raised.

The mower lock levers (latches) may be used for the following operations.

- Moving by the machine
- Transporting the machine
- Storing the machine

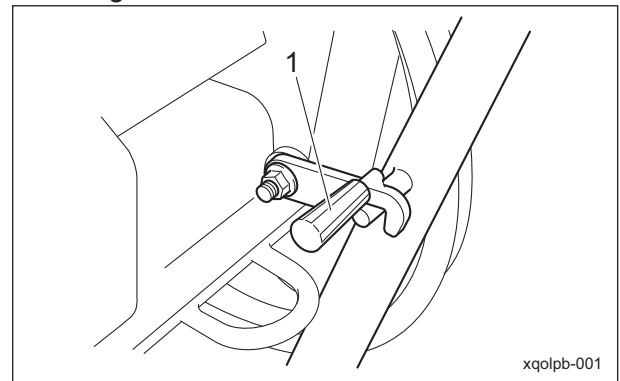

Mower Lock Lever (Latch)_001

1	Mower lock lever (latch)
---	--------------------------

Mower Unit Up/Down Lever

Caution

Before raising or lowering the mower units, make sure that there are no people around the machine.

Important

When the mower lock levers (latches) are engaged, do not operate the mower unit up/down lever.

The mower unit up/down lever is located in the operation panel and raises or lowers the mower units.

When the lever is shifted to the "DOWN" position, the mower units are lowered. When the lever is shifted to the "UP" position, the mower units are raised.

Release the lever to return it to the neutral position.

Handling Instructions

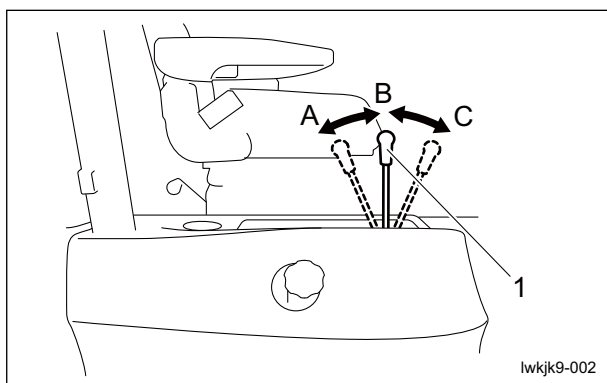

Mower Unit Up/Down Lever_001

1	Mower unit up/down lever
A	UP
B	Neutral
C	DOWN

Note:
When the mower units are raised, the reels stop rotating, even if the reel rotation switch is set to the "Rotation" position.

Throttle Knob

The throttle knob is located to the right of the driver's seat and enables you to adjust the engine rpm. Move the throttle knob toward the "High speed" position to increase the engine rpm, and toward the "Low speed" to reduce the rpm.

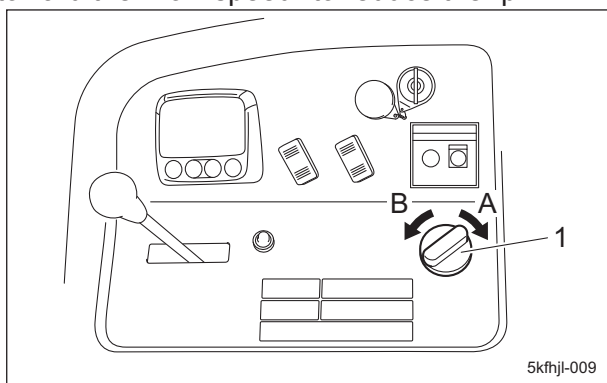

Throttle Knob_001

1	Throttle knob
A	High speed
B	Low speed

Diff-Lock Switch

Note:
Depending on the specifications, this function may not be available.

Important

Do not operate the diff-lock switch unless it is necessary.

The diff-lock switch is located below the right side of the steering wheel and engages the differential lock for the left and right front wheels. Tilt the switch lever up or down to turn "ON" to engage the differential lock for the front wheels. Release the switch lever to return it to the neutral position ("OFF" position) and disengage the differential lock.

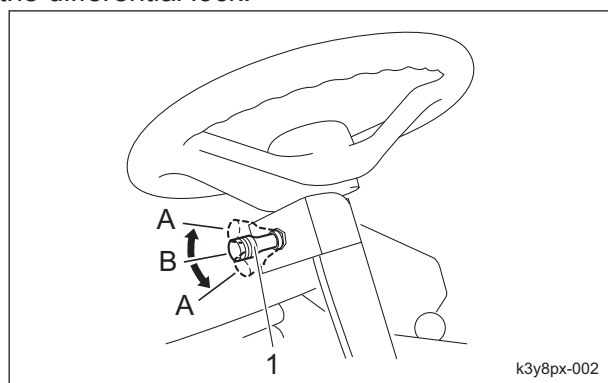

Diff-Lock Switch_001

1	Diff-lock switch
A	ON (lock)
B	OFF (release)

Handling Instructions

Traveling Pedal

1	Brake pedal
2	Parking brake lever

Caution

When the machine is traveling at a high speed, it will not stop immediately after you take your foot off the traveling pedal. If necessary, also use the brake.

The traveling pedals are located in the right foot area and control forward and reverse operation of the machine. When the forward pedal (inside) is depressed, the machine travels forward. When the reverse pedal (outside) is depressed, the machine travels in reverse. The speed changes in accordance with how much the pedal is depressed. When you take your foot off the pedal, the machine stops automatically.

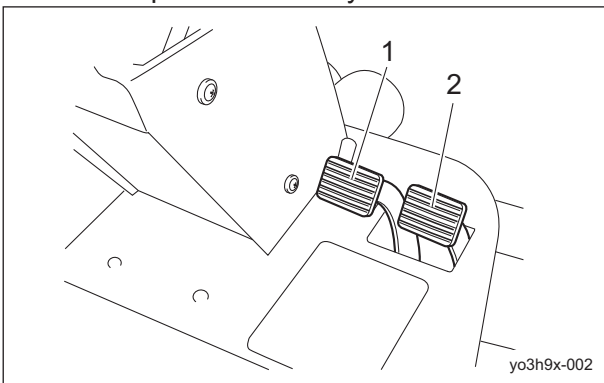

Traveling Pedal_001

1	Forward pedal
2	Reverse pedal

Parking Brake Lever

Caution

Never park the machine on a slope.

Important

Be sure to release the parking brake before driving. Otherwise, it could cause the brakes and hydraulic equipments to malfunction.

The parking brake lever is located to the left of the front cover. When parking, depress the brake pedal, and then pull the parking brake lever completely. To release the parking brake, depress the brake pedals.

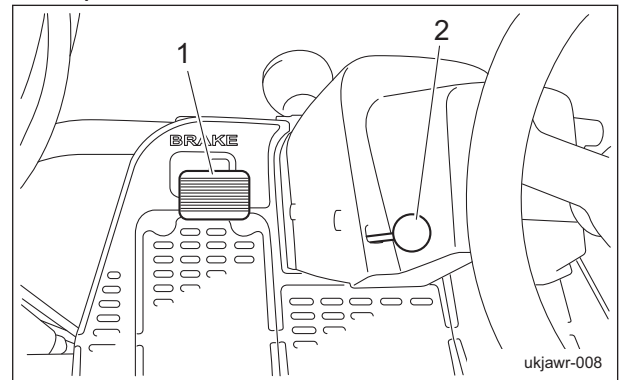

Parking Brake Lever_001

1	Brake pedals
2	Parking brake lever

Brake Pedal

The brake pedal is located in the left foot area. To stop the machine, depress the brake pedal when needed.

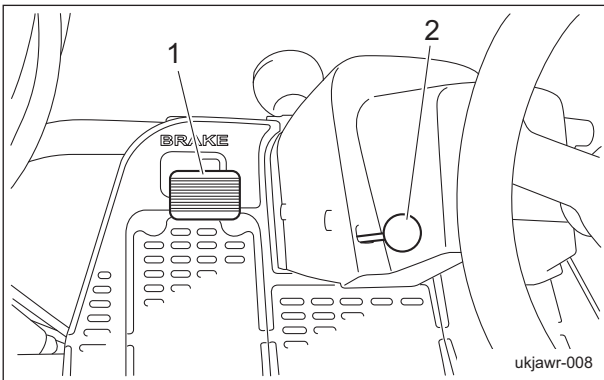

Brake Pedal_001

Handling Instructions

Hood

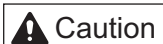

Caution

Do not open the hood in strong winds.

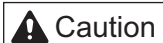

Caution

Be careful not to pinch your fingers when you open or close the hood.

1. Unlock the rubber catch, and then lift up the hood.
2. Hook the hood support rod onto the latch inside the hood.
Make sure that the hood will not close, and then remove your hands.

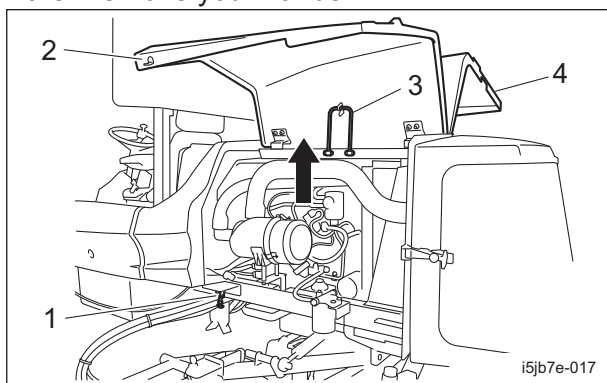

Hood_001

1	Rubber catch
2	Left hood
3	Hood support rod
4	Right hood

3. To close the hood, release the hood support rod from the latch, and then lower the hood slowly.
4. Lock the rubber catch securely.

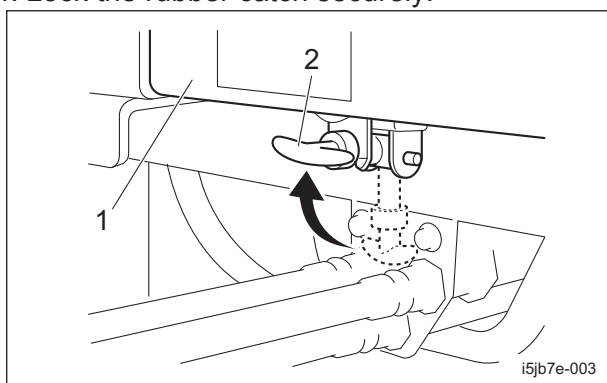

Hood_002

1	Hood
2	Rubber catch

Underseat Cover

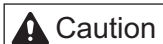

Caution

Be careful not to pinch your fingers when you open or close the underseat cover.

1. Make sure that the steering wheel is raised completely.
2. Bring the seat to the backmost position.
3. Pull up the lever behind the seat to unlock it.

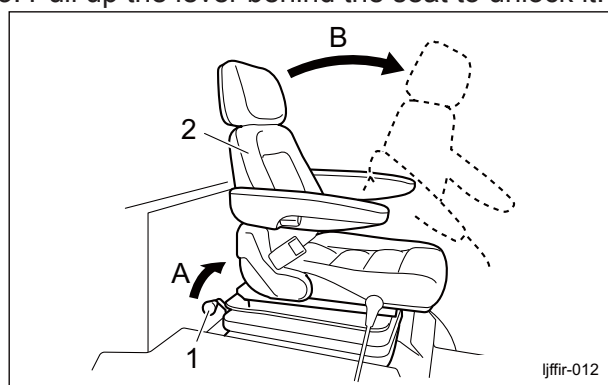

Underseat Cover_001

1	Lever
2	Seat
A	Pull up
B	Tilt forward

4. Tilt the seat forward to open the cover.
To close the cover, slowly lower the seat.

Instruments

Description of Monitor

The monitor displays various information about the machine, such as the operating status and fault conditions.

The information of desired items can be confirmed according to operating the keys.

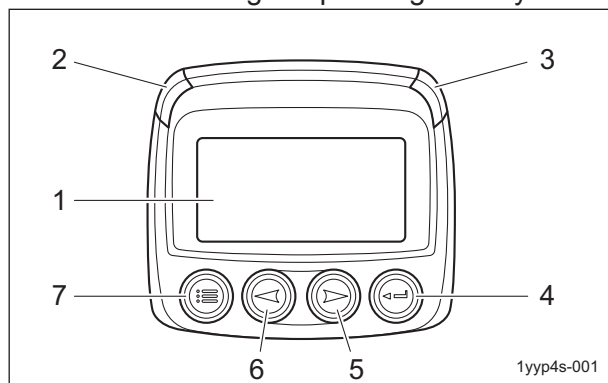

Description of Monitor_001

Handling Instructions

1	Monitor display
2	LED (yellow)
3	LED (red)
4	Enter key
5	Right arrow key
6	Left arrow key
7	Menu key

1. Monitor display
Displays machine conditions and items.
2. LED (yellow)
Lights up when a malfunction is detected, indicating warning and/or caution on the engine.
3. LED (red)
Lights up when a critical malfunction on the engine is detected.
4. Enter key
Selects the menu or parameter.
Switches between displaying/hiding the current fault code.
5. Right arrow key
Scrolls the screen.
Move the parameter selection to the right or down.
6. Left arrow key
Scrolls the screen.
Move the parameter selection to the left or up.
7. Menu key
Opens or exits the menu.

Displayed Icon

The icon appears at the top of the monitor display.

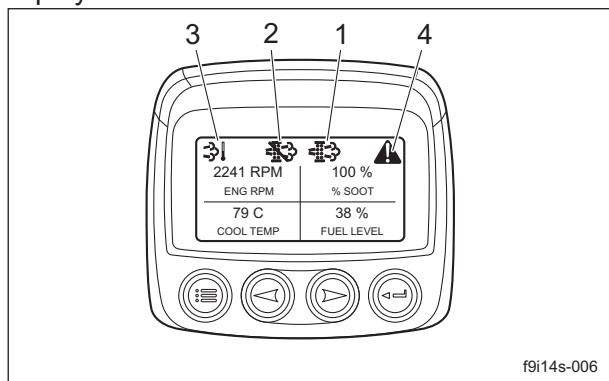

Displayed Icon_001

1	Regeneration icon
2	Auto regeneration inhibit icon
3	High exhaust temperature icon
4	Warning mark

1. Regeneration icon
The regeneration icon appears with DPF regeneration request or during DPF regeneration.
 - DPF regeneration request: Blinking
 - During DPF regeneration: Lighting
2. Auto regeneration inhibit icon
The auto regeneration inhibit icon lights up when the DPF auto regeneration inhibit switch is set to the "Auto regeneration inhibit mode".
3. High exhaust temperature icon
The high exhaust temperature icon lights up when the exhaust temperature reaches 450 °C during DPF regeneration.
4. Warning mark
The warning mark continues to be displayed in the upper right corner of the monitor display if the warning message ignored and the Enter key pressed to hide the message.
 - Service reminders
 - Low fuel level
 - Fault codes

Handling Instructions

Main Menu Items

While any parameter is displayed, press the menu key to display the main menu with the following 11 items.

- GO TO 1-UP DISPLAY / GO TO 4-UP DISPLAY
- LANGUAGES
- STORED CODES
- ENGINE CONFIGURATION
- SETUP 1-UP DISPLAY
- SETUP 4-UP DISPLAY
- SERVICE REMINDERS
- SELECT UNITS
- ADJUST BACKLIGHT
- ADJUST CONTRAST
- UTILITIES

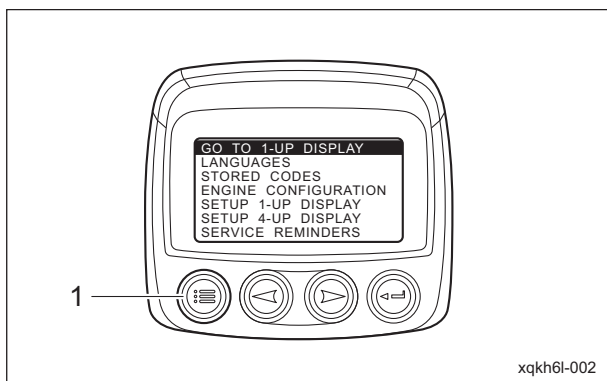

Main Menu Items_001

1	Menu key
---	----------

1-Up Display / 4-Up Display

"GO TO 1-UP DISPLAY" / "GO TO 4-UP DISPLAY" are used to set whether to display parameters individually in a screen or in groups of four per screen.

1. 1-up display

One parameter is displayed individually in the monitor display.

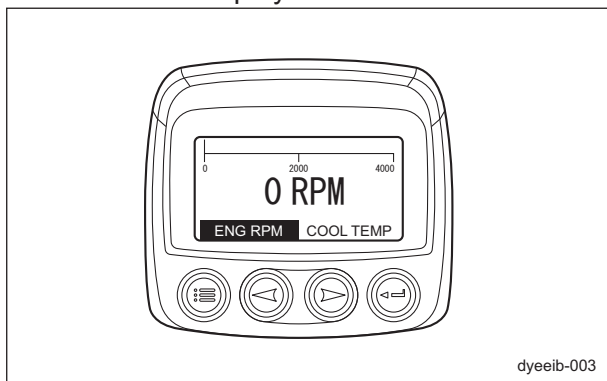

1-Up Display / 4-Up Display_001

2. 4-up display

Four parameters are displayed in the monitor display.

With the 4-up display, a total of 8 parameters are displayed over 2 pages.

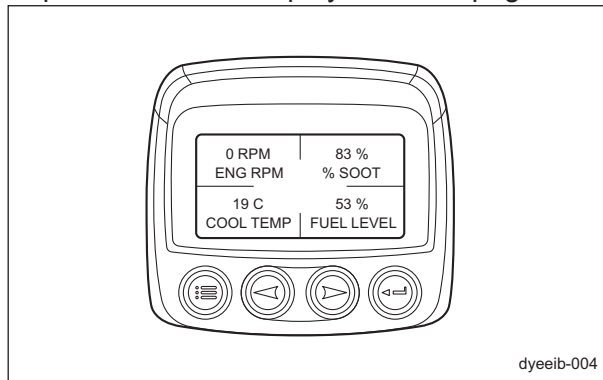

1-Up Display / 4-Up Display_002

Note:

The factory default display is the 4-up display. "GO TO 1-UP DISPLAY" appears in the main menu.

When the 1-up display is set, "GO TO 4-UP DISPLAY" appears in the main menu.

Handling Instructions

■Parameter Items

The parameters and corresponding information that appear in the monitor display are listed below.

No.	Monitor display L	Monitor display S	Description
1	ENGINE SPEED	ENG RPM	Displays the engine rpm.
2	DRIVERS DEMAND ENGINE TORQUE	DEMAND TQ	Displays the torque required by the ECU.
3	ACTUAL ENGINE TORQUE	ENG TORQ	Displays the actual torque.
4	PERCENT LOAD AT CURRENT RPM	LOAD@RPM	Displays the engine load factor.
5	ACCELERATOR PEDAL POSITION 1	ACCEL PED1	Displays the accelerator sensor opening.
6	ENGINE DESIRED OP SPEED	DES ENG SP	Displays the engine rpm required by the ECU.
7	ENGINE COOLANT TEMPERATURE	COOL TEMP	Displays the temperature measured by the coolant temperature sensor.
8	FUEL RATE	FUEL RATE	Displays the engine fuel consumption rate.
9	THROTTLE POSITION	THROTTLE	Displays the engine throttle opening.
10	BOOST PRESSURE	BST PRES	Displays the pressure measured by the intake pressure sensor.
11	INTAKE MANIFOLD TEMPERATURE	MANI TEMP	Displays the temperature measured by the intake temperature sensor built into the air flow sensor.
12	BATTERY POTENTIAL	BAT VOLT	Displays the battery voltage.
13	BAROMETRIC PRESSURE	BARO PRES	Displays the atmospheric pressure measured by the atmospheric pressure sensor.
14	AMBIENT AIR TEMP	AMB TEMP	Displays the ambient temperature.
15	AIR INLET TEMPERATURE	AIR IN TP	Displays the intake air temperature measured by the air flow sensor.
16	TOTAL FUEL USED	FUEL USED	Displays the total fuel consumption of the engine.
17	TOTAL ENGINE HOURS	ENG HRS	Displays the total time that the ECU is on (time that the key is in the "ON" position).
18	ENGINE OIL PRESSURE	OIL PRES	Displays the engine oil pressure measured by the oil pressure switch. While the engine is running: Normal=200 kPa, Abnormal=0 kPa
19	INJECTOR METERRING RAIL PRESS	RAIL PRES	Displays the fuel pressure in the rail, measured by the rail pressure sensor.
20	ENGINE INLET AIR MASS FLOW RATE	AIR RATE	Displays the intake air volume measured by the air flow sensor.
21	DOC INTAKE GAS TEMP	DOC TEMP	Displays the DOC inlet gas temperature measured by the exhaust temperature sensor.
22	EXHAUST FILTER INLET TEMP	EF IN T	Displays the DPF inlet gas temperature measured by the exhaust temperature sensor.
23	DPF DIFFERENCE PRESSURE	DIFF PRES	Displays the pressure difference before and after the DPF, measured by the differential pressure sensor.

Handling Instructions

No.	Monitor display L	Monitor display S	Description
24	EXHAUST FILTER OUTLET TEMP	EF OUT T	Displays the DPF outlet gas temperature measured by the exhaust temperature sensor.
25	PARTICULATE TRAP LAMP	PT LAMP	Shows the status of the regeneration icon. Icon not displayed="OFF", Icon blinking="ON BLINK", Icon solid="ON SOLID"
26	DPF STATUS	DPF ST	Shows the status of the DPF. DPF regeneration not needed="REGEN NOT NEEDED" DPF regeneration needed=(Level 1="NEEDED LOWEST", Level 2-3="NEEDED MODERATE", Level 4="NEEDED HIGHEST")
27	DPF ACTIVE REGEN STATUS	DPF AR ST	Shows the DPF regeneration status. Regeneration not needed="INACTIVE", Regeneration needed="NEEDED", Regenerating="ACTIVE"
28	DPF REGEN INHIBIT STATUS	INHIBIT ST	Shows the ECU auto regeneration inhibited status. Auto regeneration inhibit switch off="OFF", Auto regeneration inhibit switch on="ON"
29	DPF REGENERATION INHIBITED SW	DPF INHIB SW	Shows the status of auto regeneration inhibit switch. Auto regeneration inhibit switch off="OFF", Auto regeneration inhibit switch on="ON"
30	EXHAUST HIGH TEMP LAMP	EXH T LAMP	Displays the condition of the exhaust temperature. 450 °C or more="ON", 450 °C or less="OFF"
31	%SOOT	%SOOT	Displays the amount of soot accumulated in the DPF.
32	MACHINE HOURS	MACH HRS	Displays the total operating time of the machine (time that the engine was actually running).
33	FUEL LEVEL	FUEL LEVEL	Displays the quantity of fuel remaining in the fuel tank.

Note:

When display settings are being specified, the parameters appear on "Monitor display L".
At all other times, the parameters appear on "Monitor display S".

Handling Instructions

Language

With "LANGUAGES", the language used in the monitor display can be set to either of the following two.

- ENGLISH
- JAPANESE

An asterisk appears at the right of the currently selected language.

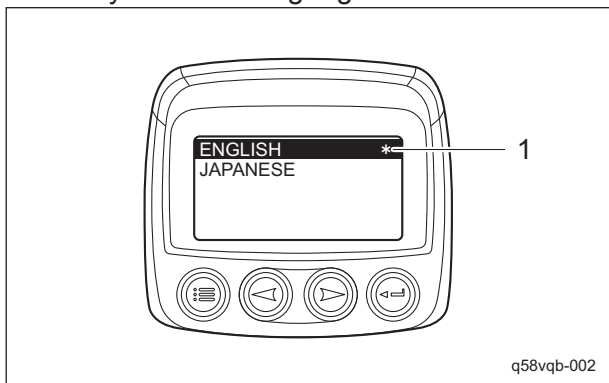

Language_001

1	Asterisk
---	----------

Note:

The factory default language is "ENGLISH".

Fault Code Log

With "STORED CODES", a log of past fault codes can be checked.

When there is a fault code log, each fault is displayed over two pages.

Use the arrow keys to change the page.

- Text 1

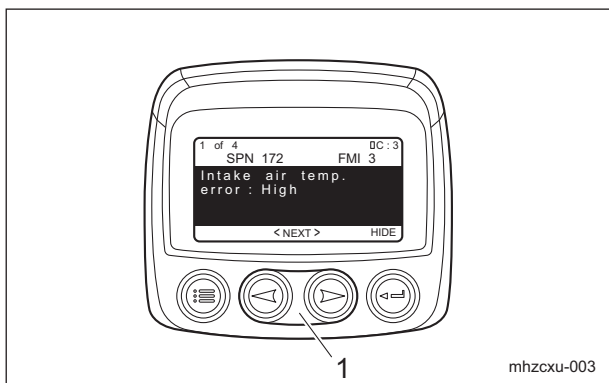

Fault Code Log_001

1	Arrow keys
---	------------

- Text 2

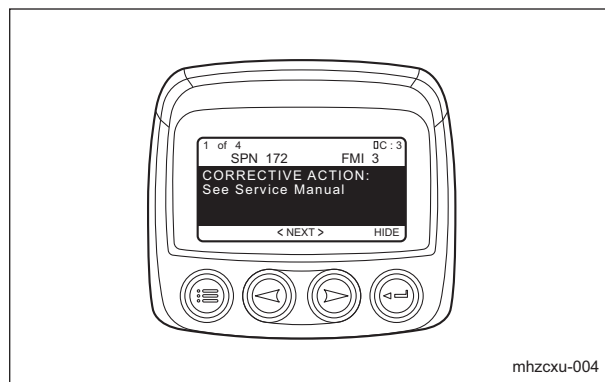

Fault Code Log_002

If there is no fault code log, "NO STORED FAULT CODES" appears.

Handling Instructions

■List of Fault Codes

Important

When the fault code appears in the monitor display, refer to "Kubota DIAGNOSIS MANUAL COMMON RAIL SYSTEM" or contact your dealer.

The fault codes (DTC) and corresponding information that appear in the monitor display are listed below.

No.	DTC name Text 1	Corrective action Text 2	ISO 14229 P-Code	J1939-73		Detection item	Remark	Behavior During Malfunction	Recovery from error
				SPN	FMI				
1	NE-G phase shift NE: Crankshaft position sensor G: Camshaft position sensor	See Service Manual	P0016	636	7	Large phase shift between NE pulse and G pulse	<ul style="list-style-type: none"> NE: Crankshaft position sensor G: Camshaft position sensor 	(Invalid G signal) - Engine hesitates at start-up	Diagnostic counter = zero
2	Pressure limiter emergency open	See Service Manual	P0087	633	7	Pressure limiter emergency open	To minimize PM emission to DPF Engine speed may go down due to lack of fuel pressure, regardless limp home de-rating	<ul style="list-style-type: none"> Insufficient output Worsening exhaust gas emissions 	Key switch turn OFF
3	High rail pressure	See Service Manual	P0088	157	0	Actual pressure exceeds the command pressure	To minimize PM emission to DPF	<ul style="list-style-type: none"> Insufficient output Worsening exhaust gas emissions 	Key switch turn OFF
4	SCV (MPROP) stuck	See Service Manual	P0089	1347	7	SCV stuck at open position (Actual rail pressure continuously exceeds the command rail pressure)	To minimize PM emission to DPF	<ul style="list-style-type: none"> Insufficient output Worsening exhaust gas emissions Engine stops in some cases 	Key switch turn OFF
5	Fuel leak (in high pressured fuel system)	Stop ENG See Service Manual	P0093	1239	1	Fuel leak from high pressured fuel system (Fuel consumption is calculated from the difference of fuel pressure of before and after the injection, and the error will be detected when excess fuel	To minimize PM emission to DPF	<ul style="list-style-type: none"> Insufficient output Worsening exhaust gas emissions Engine stops in some cases 	Key switch turn OFF

Handling Instructions

No.	DTC name Text 1	Corrective action Text 2	ISO 14229 P-Code	J1939-73		Detection item	Remark	Behavior During Malfunction	Recovery from error
				SPN	FMI				
5	Fuel leak (in high pressured fuel system)	Stop ENG See Service Manual	P0093	1239	1	consumption is found)	To minimize PM emission to DPF	- Insufficient output - Worsening exhaust gas emissions - Engine stops in some cases	Key switch turn OFF
6	Intake air temp. error: Low	See Service Manual	P0112	172	4	Ground short circuit of sensor or harness		- White smoke increases at low temperature	Diagnostic counter = zero
7	Intake air temp. error: High	See Service Manual	P0113	172	3	Open circuit or +B short circuit of sensor or harness		- White smoke increases at low temperature	Diag counter = zero
8	Coolant temperature sensor: Low	See Service Manual	P0117	110	4	Ground short circuit of sensor or harness		- White smoke increases at low temperature - Insufficient output - Worsening exhaust gas emissions	Key switch turn OFF
9	Coolant temperature sensor: High	See Service Manual	P0118	110	3	Open circuit or +B short circuit of sensor or harness		- White smoke increases at low temperature - Insufficient output - Worsening exhaust gas emissions	Key switch turn OFF
10	Rail pressure sensor: Low	Stop ENG See Service Manual	P0192	157	4	Ground short circuit of sensor or harness Failure of sensor	To minimize PM emission to DPF	- Insufficient output - Worsening exhaust gas emissions - Engine running noise increases - White smoke increases - Engine stops	Key switch turn OFF

Handling Instructions

No.	DTC name Text 1	Corrective action Text 2	ISO 14229 P-Code	J1939-73		Detection item	Remark	Behavior During Malfunction	Recovery from error
				SPN	FMI				
11	Rail pressure sensor: High	Stop ENG See Service Manual	P0193	157	3	Open circuit or +B short circuit of sensor or harness Failure of sensor	To minimize PM emission to DPF	- Insufficient output - Worsening exhaust gas emissions - Engine running noise increases - White smoke increases - Engine stops	Key switch turn OFF
12	Injector charge voltage: High	Stop ENG See Service Manual	P0200	523535	0	Injector charge voltage: High		- Insufficient output - Worsening exhaust gas emission - Engine stops	Key switch turn OFF
13	Open circuit of harness or coil in 1st cylinder injector	See Service Manual	P0201	651	3	Open circuit of harness Open circuit of injector coil	To minimize PM emission to DPF Injectors which have no error are operated	- Insufficient output - Engine vibration increases - Worsening exhaust gas emissions	Key switch turn OFF
14	Open circuit of harness or coil in 3rd cylinder injector	See Service Manual	P0202	653	3	Open circuit of harness Open circuit of injector coil	To minimize PM emission to DPF Injectors which have no error are operated	- Insufficient output - Engine vibration increases - Worsening exhaust gas emissions	Key switch turn OFF
15	Open circuit of harness or coil in 4th cylinder injector	See Service Manual	P0203	654	3	Open circuit of harness Open circuit of injector coil	To minimize PM emission to DPF Injectors which have no error are operated	- Insufficient output - Engine vibration increases - Worsening exhaust gas emissions	Key switch turn OFF
16	Open circuit of harness or coil in 2nd cylinder injector	See Service Manual	P0204	652	3	Open circuit of harness Open circuit of injector coil	To minimize PM emission to DPF Injectors which have no error are operated	- Insufficient output - Engine vibration increases - Worsening exhaust gas emissions	Key switch turn OFF
17	Engine overheat	Stop mowing!!	P0217	110	0	Overheat of engine coolant temperature		- Insufficient output - Overheat	Diagnostic counter = zero

Handling Instructions

No.	DTC name Text 1	Corrective action Text 2	ISO 14229 P-Code	J1939-73		Detection item	Remark	Behavior During Malfunction	Recovery from error
				SPN	FMI				
18	Engine overrun	See Service Manual	P0219	190	0	Engine speed exceeds threshold speed		- Overrun	Diagnostic counter = zero
19	Boost pressure sensor: Low	See Service Manual	P0237	102	4	Ground short circuit of sensor or harness Failure of sensor	Default value is set in consideration with high altitude usage	- Insufficient output	Key switch turn OFF
20	Boost pressure sensor: High	See Service Manual	P0238	102	3	Open circuit or +B short circuit of sensor or harness Failure of sensor	Default value is set in consideration with high altitude usage	- Insufficient output	Key switch turn OFF
21	No input of NE sensor (Crank position sensor) pulse	See Service Manual	P0335	636	8	Open circuit or short circuit of sensor or harness Failure of sensor		(Running only with G signal) - Faulty starting - Engine Vibration increases slightly - Insufficient output	Key switch turn OFF
22	NE sensor (Crank position sensor) pulse number error	See Service Manual	P0336	636	2	Open circuit or short circuit of sensor or harness Failure of sensor		(Running only with G signal) - Faulty starting - Engine Vibration increases slightly - Insufficient output	Key switch turn OFF
23	No input of G sensor (Camshaft position sensor) pulse	See Service Manual	P0340	723	8	Open circuit or short circuit of sensor or harness Failure of sensor		(Invalid G signal) - Engine hesitates at start-up	Diagnostic counter = zero
24	G-sensor (Camshaft position sensor) pulse number error	See Service Manual	P0341	723	2	Open circuit or short circuit of sensor or harness Failure of sensor		(Invalid G signal) - Engine hesitates at start-up	Diagnostic counter = zero
25	Open circuit of glow relay driving circuit	See Service Manual	P0380	676	5	Open circuit of air glow relay		(At low temperature) - Faulty starting - White smoke increases	Key switch turn OFF
26	+B short of glow relay driving circuit	See Service Manual	P0380	523544	3	+B short of glow relay driving circuit		(At low temperature) - Faulty starting - White smoke increases	Key switch turn OFF

Handling Instructions

No.	DTC name Text 1	Corrective action Text 2	ISO 14229 P-Code	J1939-73		Detection item	Remark	Behavior During Malfunction	Recovery from error
				SPN	FMI				
27	Ground short of glow relay driving circuit	See Service Manual	P0380	523544	4	Ground short of glow relay driving circuit		(At low temperature) - Faulty starting - White smoke increases	Key switch turn OFF
28	Glow heater relay driving circuit overheat	See Service Manual	P0381	676	0	Overheat of glow plug driving circuit		(At low temperature) - Faulty starting - White smoke increases	Key switch turn OFF
29	Oil pressure error	Stop ENG See Service Manual	P0524	100	1	Oil pressure switch		- Engine stops	Key switch turn OFF
30	Battery voltage: Low	See Service Manual	P0562	168	4	Open circuit, short circuit or damage of harness Failure of battery		- Faulty starting - Insufficient output - Worsening exhaust gas emissions - Engine stops in some cases	Diagnostic counter = zero
31	Battery voltage: High	See Service Manual	P0563	168	3	Open circuit, short circuit or damage of harness Failure of battery		- Faulty starting - Insufficient output - Worsening exhaust gas emissions	Key switch turn OFF
32	QR (IQA) data error	Contact dealer	P0602	523538	2	QR data read error	To cover each injector dispersion	- Insufficient output	Diagnostic counter = zero Key switch turn OFF
33	No QR (IQA) data	Contact dealer	P0602	523538	7	QR data is unwritten		- Insufficient output	Diagnostic counter = zero Key switch turn OFF
34	ECU FLASH ROM error	Stop ENG See Service Manual	P0605	628	2	FLASH ROM error		- Engine stops	Key switch turn OFF
35	ECU CPU (Main IC) error	Stop ENG See Service Manual	P0606	1077	2	Failure of CPU and/or IC		- Engine stops	Key switch turn OFF
36	ECU CPU (Monitoring IC) error	Stop ENG See Service Manual	P0606	523527	2	Failure of monitoring IC of CPU		- Engine stops	Key switch turn OFF

Handling Instructions

No.	DTC name Text 1	Corrective action Text 2	ISO 14229 P-Code	J1939-73		Detection item	Remark	Behavior During Malfunction	Recovery from error
				SPN	FMI				
37	Injector charge voltage: Low	Stop ENG See Service Manual	P0611	523525	1	Injector charge voltage: Low Failure of charge circuit of ECU		- Insufficient output - Worsening exhaust gas emissions - Engine stops	Key switch turn OFF
38	Open circuit of SCV (MPROP)	Stop ENG See Service Manual	P0627	1347	5	Open circuit of SCV (MPROP)		- Insufficient output - Worsening exhaust gas emissions	Key switch turn OFF
39	SCV (MPROP) drive system error	Stop ENG See Service Manual	P0628	1347	4	Ground short circuit of SCV (MPROP)		- Insufficient output - Worsening exhaust gas emissions	Key switch turn OFF
40	+B short circuit of SCV (MPROP)	See Service Manual	P0629	1347	3	+B short circuit of SCV (MPROP)		- Insufficient output - Worsening exhaust gas emissions	Key switch turn OFF
41	Injector drive IC error or Open circuit	Stop ENG See Service Manual	P062B	1077	12	Injector drive IC error or Open circuit of No.1 & 4 cylinder injector or Open circuit of No.2 & 3 cylinder injector		- Engine stops	Key switch turn OFF
42	Internal injector drive circuit short	Stop ENG See Service Manual	P062D	523605	6	Short circuit in Injector driver IC		- Insufficient output - Engine Vibration increases - Worsening exhaust gas emissions - Engine stops in some cases	Key switch turn OFF
43	Sensor supply voltage 1: Low	See Service Manual	P0642	3509	4	Sensor supply voltage 1 error or recognition error	Emission related	- Faulty starting - Insufficient output - Worsening exhaust gas emissions - Engine stops in some cases	Key switch turn OFF

Handling Instructions

No.	DTC name Text 1	Corrective action Text 2	ISO 14229 P-Code	J1939-73		Detection item	Remark	Behavior During Malfunction	Recovery from error
				SPN	FMI				
44	Sensor supply voltage 1: High	See Service Manual	P0643	3509	3	Sensor supply voltage 1 error or recognition error	Emission related	- Faulty starting - Insufficient output - Worsening exhaust gas emissions - Engine stops in some cases	Key switch turn OFF
45	Sensor supply voltage 2: Low	See Service Manual	P0652	3510	4	Sensor supply voltage 2 error or recognition error	Emission related	- Faulty starting - Insufficient output - Worsening exhaust gas emissions	Key switch turn OFF
46	Sensor supply voltage 2: High	See Service Manual	P0653	3510	3	Sensor supply voltage 2 error or recognition error	Emission related	- Faulty starting - Insufficient output - Worsening exhaust gas emissions	Key switch turn OFF
47	Sensor supply voltage 3: Low	See Service Manual	P0662	3511	4	Sensor supply voltage 3 error or recognition error		- Faulty starting	Key switch turn OFF
48	Sensor supply voltage 3: High	See Service Manual	P0663	3511	3	Sensor supply voltage 3 error or recognition error		- Faulty starting	Key switch turn OFF
49	Main relay is locked in closed position	See Service Manual	P0687	1485	2	Failure of main relay		- Battery goes dead	Key switch turn OFF
50	Ground short of Starter relay driving circuit	See Service Manual	P081A	677	4	Ground short of Starter relay driving circuit		- Faulty starting	Key switch turn OFF
51	Accelerator position sensor 1: Low	See Service Manual	P2122	91	4	Ground short circuit or open circuit of sensor or harness		- Insufficient output	Diagnostic counter = zero
52	Accelerator position sensor 1: High	See Service Manual	P2123	91	3	Battery short circuit out of sensor or harness		- Insufficient output	Diagnostic counter = zero
53	Accelerator position sensor 2: Low	See Service Manual	P2127	29	4	Ground short circuit or open circuit of sensor or harness		- Insufficient output	Diagnostic counter = zero
54	Accelerator position sensor 2: High	See Service Manual	P2128	29	3	Battery short circuit out of sensor or harness		- Insufficient output	Diagnostic counter = zero

Handling Instructions

No.	DTC name Text 1	Corrective action Text 2	ISO 14229 P-Code	J1939-73		Detection item	Remark	Behavior During Malfunction	Recovery from error
				SPN	FMI				
55	Accelerator Position Sensor Error (CAN)	See Service Manual	P2131	523543	2	Accelerator position sensor signal error (sensor or harness open circuit, ground short circuit etc.)		- Insufficient output	Diagnostic counter = zero (CAN signal recovers)
57	No. 1 & 4 cylinder injector short to +B or GND	Stop ENG See Service Manual	P2148	523523	3	Wiring harness short to +B or Wiring harness short to ground	To minimize PM emission to DPF Injectors which have no error are operated	- Insufficient output - Engine Vibration increases - Worsening exhaust gas emissions - Engine stops in some cases	Key switch turn OFF
59	No. 2 & 3 cylinder injector short to +B or GND	Stop ENG See Service Manual	P2151	523524	3	Wiring harness short to +B or Wiring harness short to ground	To minimize PM emission to DPF Injectors which have no error are operated	- Insufficient output - Engine Vibration increases - Worsening exhaust gas emissions - Engine stops in some cases	Key switch turn OFF
60	Barometric pressure sensor error (Low side)	See Service Manual	P2228	108	4	Sensor or ECU internal circuit short to ground	Default value is set in consideration with high altitude usage	- Insufficient output	Diagnostic counter = zero
61	Barometric pressure sensor error (High side)	See Service Manual	P2229	108	3	Sensor or ECU internal circuit short to +B	Default value is set in consideration with high altitude usage	- Insufficient output	Diagnostic counter = zero
62	Pressure limiter not open	See Service Manual	P2293	679	7	Rail pressure value is sticking or too low engine power not to open PL valve forcibility		- Engine stops	Key switch turn OFF
63	CAN1 Bus off	See Service Manual	U0077	523604	2	CAN1 +B or GND short circuit or high traffic error		- Insufficient output - Transmitted CAN data are invalid	Key switch turn OFF

Handling Instructions

No.	DTC name Text 1	Corrective action Text 2	ISO 14229 P-Code	J1939-73		Detection item	Remark	Behavior During Malfunction	Recovery from error
				SPN	FMI				
64	CAN2 Bus off	See Service Manual	U0075	523547	2	CAN2 +B or GND short circuit or high traffic error		- Insufficient output - Transmitted CAN data are invalid	Key switch turn OFF
65	CAN-KBT Frame error	See Service Manual	U0081	523548	2	CAN-KBT original frame open circuit error		- Insufficient output	Key switch turn OFF
66	Intake air temp. built-in MAF sensor: Low	See Service Manual	P0072	171	4	Ground short circuit of sensor or harness		None	Diagnostic counter = zero
67	Intake air temp. built-in MAF sensor: High	See Service Manual	P0073	171	3	Open circuit or +B short circuit of sensor or harness		None	Diagnostic counter = zero
68	Intake air volume: Low	See Service Manual	P0101	132	1	Engine inlet air mass flow rate lacking (Disconnect turbo blower intake hose)		- Insufficient output	Key switch turn OFF
70	MAF sensor: High	See Service Manual	P0103	132	3	+B short circuit of sensor or harness	Engine is not stopped forcibly by ECU However KUBOTA strongly recommends operator to stop engine as soon as possible	- Insufficient output - Worsening exhaust gas emissions	Key switch turn OFF
71	EGR actuator open circuit	See Service Manual	P0403	523574	3	EGR actuator open circuit		- Insufficient output - Worsening exhaust gas performance	Key switch turn OFF
72	EGR actuator coil short	See Service Manual	P0404	523574	4	EGR actuator coil short		- Insufficient output - Worsening exhaust gas emissions	Key switch turn OFF
73	EGR position sensor failure	See Service Manual	P0409	523572	4	EGR position sensor failure		- Insufficient output - Worsening exhaust gas emissions	Key switch turn OFF
74	Exhaust gas temperature sensor 1: Low	See Service Manual	P0543	3242	4	Ground short circuit of sensor or harness		None	Key switch turn OFF

Handling Instructions

No.	DTC name Text 1	Corrective action Text 2	ISO 14229 P-Code	J1939-73		Detection item	Remark	Behavior During Malfunction	Recovery from error
				SPN	FMI				
75	Exhaust gas temperature sensor 1: High	See Service Manual	P0544	3242	3	Open circuit or +B short circuit of sensor or harness		None	Key switch turn OFF
76	Exhaust gas temperature sensor 0: Low	See Service Manual	P0546	4765	4	Ground short circuit of sensor or harness		None	Key switch turn OFF
77	Exhaust gas temperature sensor 0: High	See Service Manual	P0547	4765	3	Open circuit or +B short circuit of sensor or harness		None	Key switch turn OFF
78	EEPROM check sum error	See Service Manual	P1990	523700	13	KBT-EEPROM check sum error		None	Key switch turn OFF
79	EEPROM check sum error (DST1)	See Service Manual	P1991	523701	13	DST1-EEPROM check sum error		None	Key switch turn OFF
80	EEPROM check sum error (DST2)	See Service Manual	P1992	523702	13	DST2-EEPROM check sum error		None	Key switch turn OFF
81	Intake throttle feedback error	See Service Manual	P2108	523580	2	Intake throttle feedback error		None	Key switch turn OFF
82	Accelerator position sensor correlation error	See Service Manual	P2135	91	2	Deviation from designed correlation in two sensors		- Insufficient output	Diagnostic counter = zero
83	EGR actuator valve stuck	See Service Manual	P2413	523575	7	EGR actuator valve stuck		- Insufficient output - Worsening exhaust gas performance	Key switch turn OFF
84	EGR (DC motor) overheat	See Service Manual	P2414	523576	2	EGR (DC motor) overheat		- Insufficient output - Worsening exhaust gas emissions	Key switch turn OFF
85	EGR (DC motor) temp. sensor failure	See Service Manual	P2415	523577	2	EGR (DC motor) temp. sensor failure		- Insufficient output - Worsening exhaust gas emissions	Key switch turn OFF
86	Exhaust gas temperature sensor 2: Low	See Service Manual	P242C	3246	4	Ground short circuit of sensor or harness		None	Key switch turn OFF
87	Exhaust gas temperature sensor 2: High	See Service Manual	P242D	3246	3	Open circuit or +B short circuit of sensor or harness		None	Key switch turn OFF

Handling Instructions

No.	DTC name Text 1	Corrective action Text 2	ISO 14229 P-Code	J1939-73		Detection item	Remark	Behavior During Malfunction	Recovery from error
				SPN	FMI				
88	Differential pressure sensor 1: Low	See Service Manual	P2454	3251	4	Ground short circuit of sensor or harness		None	Key switch turn OFF
90	Intake throttle lift sensor: Low	See Service Manual	P2621	523582	4	Intake throttle lift sensor: Low		None	Key switch turn OFF
91	Intake throttle lift sensor: High	See Service Manual	P2622	523582	3	Intake throttle lift sensor: High		None	Key switch turn OFF
92	Emission deterioration	See Service Manual	P3001	3252	0	DOC is heated up due to unburned fuel	To minimize PM emission to DPF	- Insufficient output	Key switch turn OFF
93	Emergency Exhaust gas temperature sensor 0: High	Stop ENG See Service Manual	P3002	4765	0	DOC inlet temp. (T0): High	<ul style="list-style-type: none"> In case engine ECU is not involved to drive starter, starter activation should be inhibited by other way until exhaust temp. reduces down to 300 degC (572 degF) 	<ul style="list-style-type: none"> Engine stops Inhibited cranking until down to 300 degC (572 degF) 	<ul style="list-style-type: none"> Engine stops Inhibited cranking until down to 300 degC (572 degF)
94	Emergency Exhaust gas temperature sensor 1: High	Stop ENG See Service Manual	P3003	3242	0	DPF inlet temp. (T1): High	<ul style="list-style-type: none"> In case engine ECU is not involved to drive starter, starter activation should be inhibited by other way until exhaust temp. reduces down to 300 degC (572 degF) 	<ul style="list-style-type: none"> Engine stops Inhibited cranking until down to 300 degC (572 degF) 	Under 300 degC & Key switch turn OFF
95	Emergency Exhaust gas temperature sensor 2: High	Stop ENG See Service Manual	P3004	3246	0	DPF outlet temp. (T2): High	<ul style="list-style-type: none"> In case engine ECU is not involved to drive starter, starter activation should be inhibited by other way until exhaust temp. reduces down to 300 degC (572 degF) 	<ul style="list-style-type: none"> Engine stops Inhibited cranking until down to 300 degC (572 degF) 	Under 300 degC & Key switch turn OFF
96	Excessive PM3	Start DPF Parked Regeneration immediately	P3006	3701	15	PM accumulation level 3	To minimize PM emission	- Insufficient output	Diagnostic counter = zero

Handling Instructions

No.	DTC name Text 1	Corrective action Text 2	ISO 14229 P-Code	J1939-73		Detection item	Remark	Behavior During Malfunction	Recovery from error
				SPN	FMI				
97	Excessive PM4	Stop engine!! Contact dealer immediately	P3007	3701	16	PM accumulation level 4	To minimize PM emission	- Insufficient output	Diagnostic counter = zero
98	Excessive PM5	Stop engine!! Contact dealer immediately	P3008	3701	0	PM accumulation level 5	To minimize PM emission Engine is not stopped forcibly by ECU However KUBOTA strongly recommends operator to stop engine as soon as possible	- Insufficient output	Key switch turn OFF (Reset by Service tool)
99	Boost pressure: Low	See Service Manual	P3011	132	15	Disconnect the hose between the turbo blower out and intake flange Boost pressure sensor error	Engine power is restricted by boost pressure signal accordingly To minimize PM emission to DPF	- Insufficient output	Key switch turn OFF
100	Low coolant temp. in parked regeneration	See Service Manual	P3012	523589	17	During regeneration mode, Engine warm-up condition is not satisfied (coolant temp. is low)		None	Diagnostic counter = zero (Leaving from Parked active regeneration status)
101	Parked regeneration time out	See Service Manual	P3013	523590	16	Time out error: regeneration incomplete due to low temperature of DPF		None	Diagnostic counter = zero (Leaving from Parked active regeneration status)
102	All exhaust temp. sensor failure	See Service Manual	P3018	523599	0	All exhaust temp. sensor failure simultaneously		None	Diagnostic counter = zero
103	High exhaust gas temp. after emergency high temp. DTC	Stop ENG See Service Manual	P3023	523601	0	Exhaust gas temperature sensor 0, 1, 2 output		None	Diagnostic counter = zero
104	High frequency of regeneration	See Service Manual	P3024	523602	0	Time interval from the end time to the start time of the regeneration		- Worsening exhaust gas emissions (NOx)	Key switch turn OFF (Reset by Service tool)

Handling Instructions

No.	DTC name Text 1	Corrective action Text 2	ISO 14229 P-Code	J1939-73		Detection item	Remark	Behavior During Malfunction	Recovery from error
				SPN	FMI				
105	Over heat pre-caution	See Service Manual	P3025	523603	15	Coolant temp.		- Worsening exhaust gas emissions (NOx)	Diagnostic counter = zero
106	No communication with EGR	See Service Manual	U0076	523578	2	No communication with EGR		- Insufficient output - Worsening exhaust gas emissions	Key switch turn OFF
107	CAN CCVS (Parking SW and Vehicle speed) frame error	See Service Manual	U0082	523591	2	CAN_CCVS communication stopping		None	Key switch turn OFF
108	CAN CM1 (Regen SW) frame error	See Service Manual	U0083	523592	2	CAN_CM1 communication stopping		None	Key switch turn OFF
109	CAN DDC1 (Transmission) frame error	See Service Manual	U0084	523593	2	CAN_DDC1 communication stopping		None	Key switch turn OFF
110	CAN ETC2 (Neutral SW) frame error	See Service Manual	U0085	523594	2	CAN_ETC2 communication stopping		None	Key switch turn OFF
111	CAN ETC5 (Neutral SW) frame error	See Service Manual	U0086	523595	2	CAN_ETC5 communication stopping		None	Key switch turn OFF
112	CAN TSC1 frame error	See Service Manual	U0087	523596	2	CAN_TSC1 communication stopping		None	Diagnostic counter = zero
113	CAN EBC1 frame error	See Service Manual	U0089	523598	2	CAN_EBC1 communication stopping		None	Diagnostic counter = zero
114	FUEL LEVEL LOW	Refuel	None	96	17	Remaining fuel volume at specified value or less (factory default setting=10%) Can be adjusted between 10% and 80%		None	Supply fuel until remaining fuel volume reaches the specified value or above
115	Open Circuit of Differential Pressure Sensor and Exhaust Gas Temp. Sensor	See Service Manual	P1A28	3936	7	Removal of DPF	PCD	-	-

Handling Instructions

No.	DTC name Text 1	Corrective action Text 2	ISO 14229 P-Code	J1939-73		Detection item	Remark	Behavior During Malfunction	Recovery from error
				SPN	FMI				
116	Loss of DPF Function	See Service Manual	P3015	3936	2	Loss of function of DPF	PCD	-	-
117	Open Circuit of Differential pressure sensor	See Service Manual	P2455	3251	3	Open circuit or +B short circuit of sensor or harness	PCD	None	Diagnostic counter = zero
118	Open Circuit of ENG CAN Line	See Service Manual	U0076	523578	2	No communication with EGR	NCD	None	Diagnostic counter = zero
119	Open Circuit of MAF Sensor	See Service Manual	P0102	132	4	Open circuit or ground short circuit of sensor or harness	Engine is not stopped forcibly by ECU However KUBOTA strongly recommends operator to stop engine as soon as possible	- Insufficient output - Worsening exhaust gas emissions	Diagnostic counter = zero

Handling Instructions

Engine Configuration

This function is not supported.

1-Up Display Setup

With "SETUP 1-UP DISPLAY", the displayed parameters can be reset to the factory defaults, or the necessary parameters to be displayed can be selected.

The following 3 items appear when "SETUP 1-UP DISPLAY" is selected.

- USE DEFAULTS
- CUSTOM SETUP
- AUTOMATIC SCAN

■ Use Defaults

With "USE DEFAULTS", the 1-up display parameters return to the factory defaults.

1. Press the menu key. After the main menu appears, use the arrow keys to highlight "SETUP 1-UP DISPLAY", and then press the Enter key.

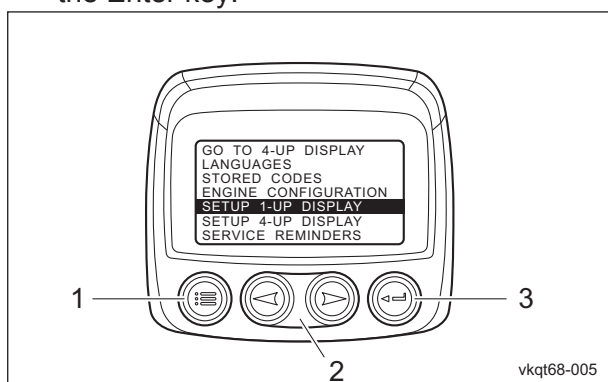

Use Defaults_001

1	Menu key
2	Arrow keys
3	Enter key

2. Highlight "USE DEFAULTS", and then press the Enter key.

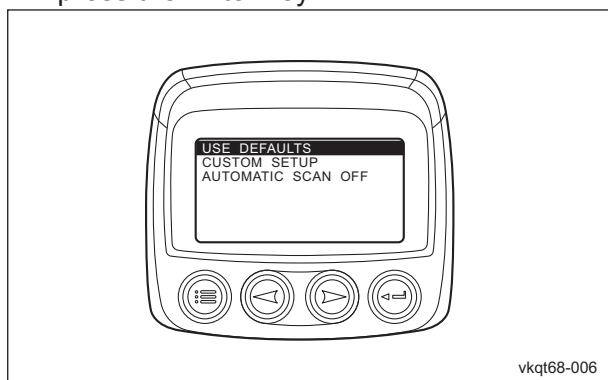

Use Defaults_002

3. "RESTORED TO DEFAULTS" appears in the monitor display, and the parameters are reset to the factory defaults of the following 8 items.

- [1] ENGINE SPEED
- [2] ENGINE COOLANT TEMPERATURE
- [3] %SOOT
- [4] FUEL LEVEL
- [5] ENGINE OIL PRESSURE
- [6] MACHINE HOURS
- [7] BATTERY POTENTIAL
- [8] DPF STATUS

4. After the settings have been applied, pressing the menu key once returns to the main menu, and pressing the key again returns to the 1-up/4-up display screen.

■ Custom Setup

With "CUSTOM SETUP", the type and number of parameters as well as their display order can be specified.

1. Press the menu key. After the main menu appears, use the arrow keys to highlight "SETUP 1-UP DISPLAY", and then press the Enter key.

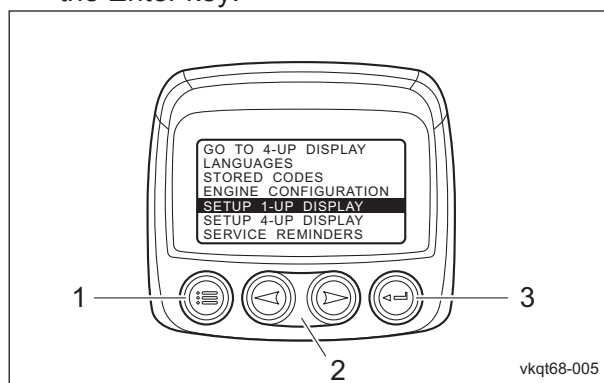

Custom Setup_001

1	Menu key
2	Arrow keys
3	Enter key

Handling Instructions

2. Highlight "CUSTOM SETUP", and then press the Enter key.
The list of parameters appears.

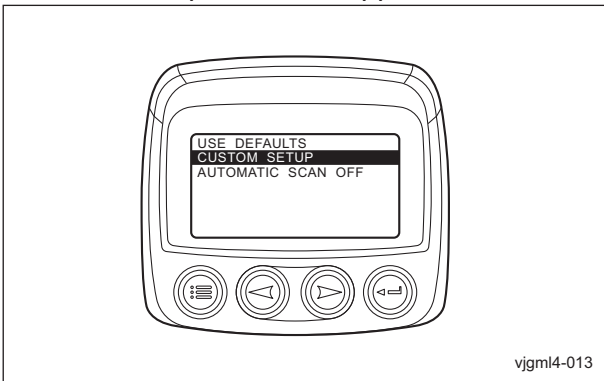

Custom Setup_002

- [2] To deselect a parameter and remove it from the list of displayed parameters
 - a. Highlight the parameter, and then press the Enter key.

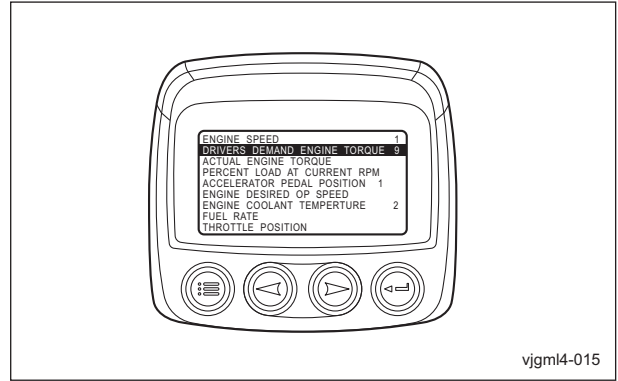

Custom Setup_005

3. Change the parameters.

- [1] To add a parameter

- a. Use the arrow keys to highlight the parameter to be added, and then press the Enter key.

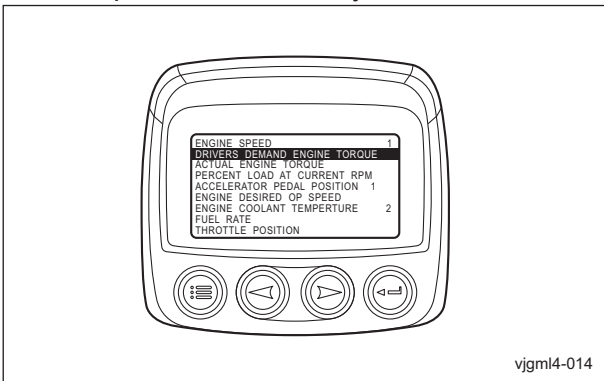

Custom Setup_003

- b. Check that the number at the right of the parameter disappeared.

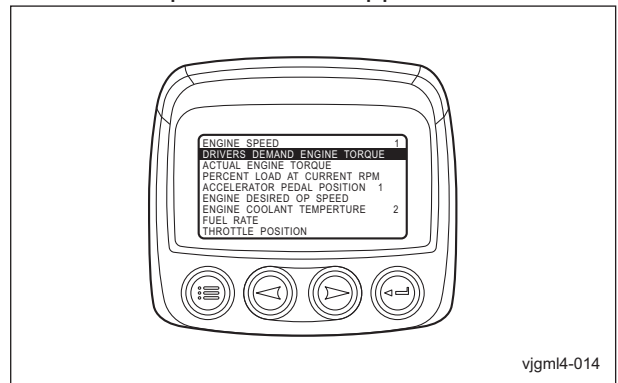

Custom Setup_006

- b. A number appears at the right of the selected parameter. This number indicates the display order for the parameter

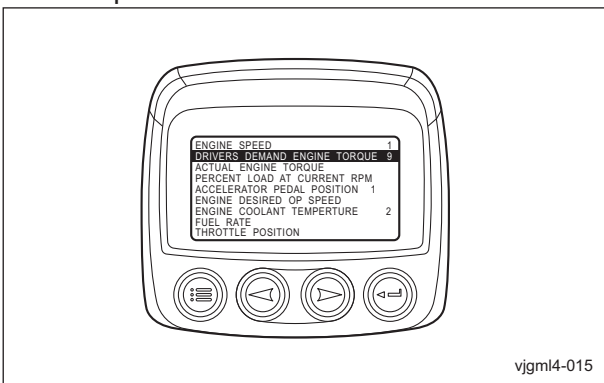

Custom Setup_004

4. After the settings have been applied, pressing the menu key once returns to the main menu, and pressing the key again returns to the 1-up/4-up display screen.

Handling Instructions

Automatic Scan

With "AUTOMATIC SCAN", the 1-up display can be set to automatically scroll through the selected parameters one by one.

1. Press the menu key.

After the main menu appears, use the arrow keys to highlight "SETUP 1-UP DISPLAY", and then press the Enter key.

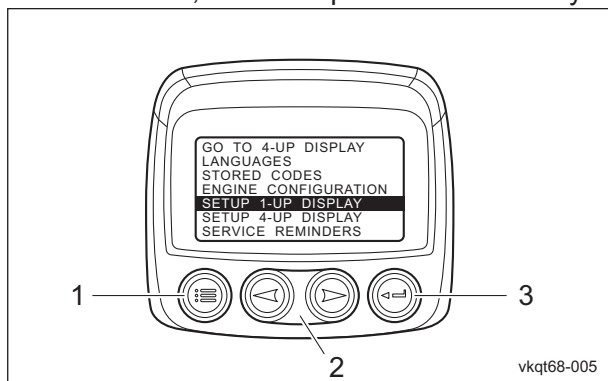

Automatic Scan_001

1	Menu key
2	Arrow keys
3	Enter key

2. When "AUTOMATIC SCAN ON" appears, the parameters are scrolled automatically. For manual scrolling, highlight "AUTOMATIC SCAN ON", and then press the Enter key.

It turns into "AUTOMATIC SCAN OFF" and the parameters will be scrolled manually.

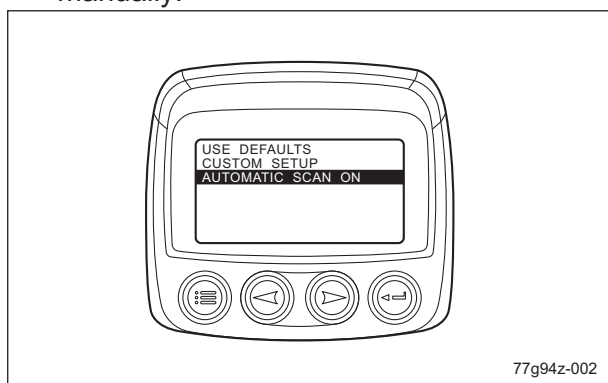

Automatic Scan_002

3. After the settings have been applied, pressing the menu key once returns to the main menu, and pressing the key again returns to the 1-up/4-up display screen.

Note:

When the parameters are scrolled automatically, press the Enter key once to pause scrolling.

When scrolling is paused, press the Enter key once to restart scrolling.

4-Up Display Setup

With "SETUP 4-UP DISPLAY", the displayed parameters can be reset to the factory defaults, or the monitor display of selected, necessary parameters can be set up.

The following 2 items appear when "SETUP 4-UP DISPLAY" is selected.

- USE DEFAULTS
- CUSTOM SETUP

Use Defaults

With "USE DEFAULTS", the 4-up display parameters return to the factory defaults.

1. Press the menu key.

After the main menu appears, use the arrow keys to highlight "SETUP 4-UP DISPLAY", and then press the Enter key.

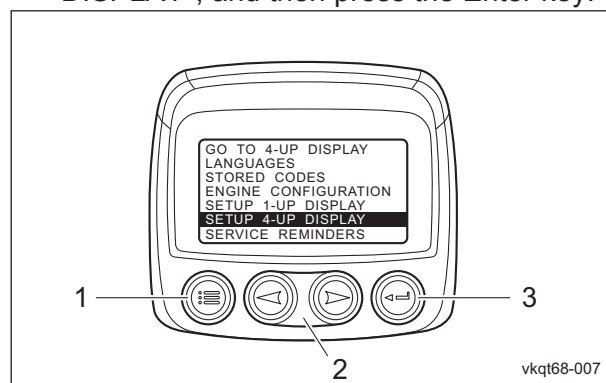

Use Defaults_001

1	Menu key
2	Arrow keys
3	Enter key

Handling Instructions

2. Highlight "USE DEFAULTS", and then press the Enter key.

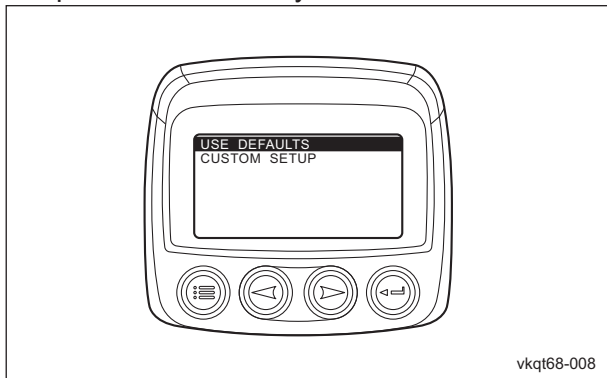

Use Defaults_002

3. "RESTORED TO DEFAULTS" appears in the monitor display, and the parameters are reset to the factory defaults of the following 8 items.

- First page
 - [1] ENGINE SPEED
 - [2] ENGINE COOLANT TEMPERATURE
 - [3] %SOOT
 - [4] FUEL LEVEL
- Second page
 - [1] ENGINE OIL PRESSURE
 - [2] MACHINE HOURS
 - [3] BATTERY POTENTIAL
 - [4] DPF STATUS

4. After the settings have been applied, pressing the menu key once returns to the main menu, and pressing the key again returns to the 1-up/4-up display screen.

■ Custom Setup

With "CUSTOM SETUP", the type and number of parameters as well as their display order can be specified.

1. Press the menu key. After the main menu appears, use the arrow keys to highlight "SETUP 4-UP DISPLAY", and then press the Enter key.

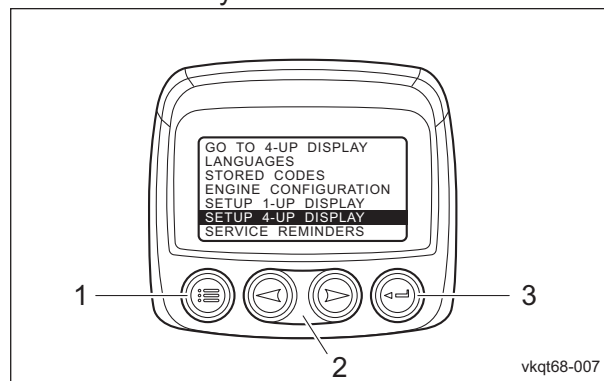

Custom Setup_001

1	Menu key
2	Arrow keys
3	Enter key

2. Highlight "CUSTOM SETUP", and then press the Enter key.

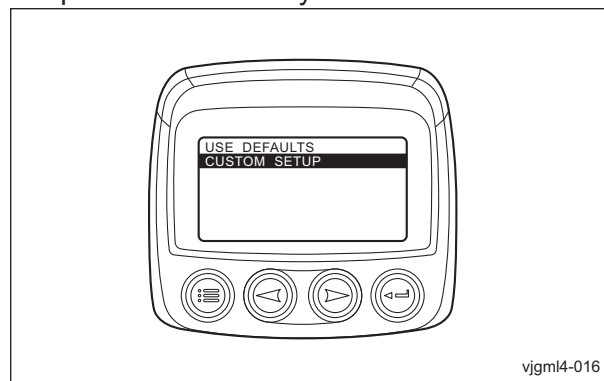

Custom Setup_002

Handling Instructions

3. Select the page.

- [1] Check that the values for the four parameters are highlighted.

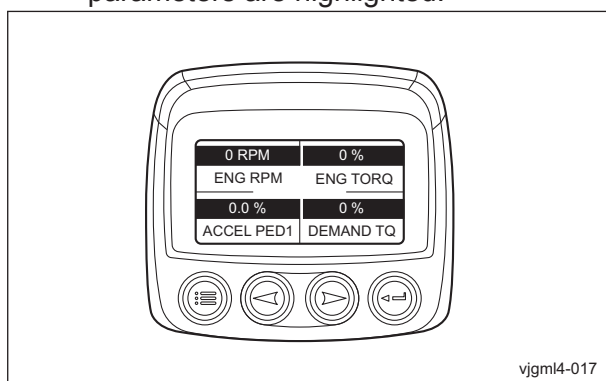

vjgml4-017

Custom Setup_003

1	Parameter values
---	------------------

- [2] Use the arrow keys to display the page to be changed, and then press the Enter key.

4. Change the parameters.

- [1] Check that the value for one parameter is highlighted.

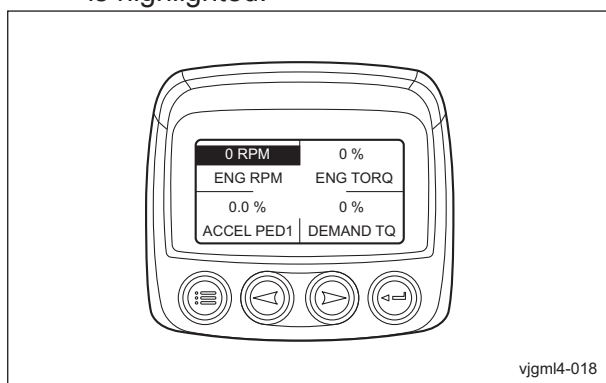

vjgml4-018

Custom Setup_004

- [2] Use the arrow keys to highlight the value of the parameter to be changed, and then press the Enter key.

- [3] The parameters appear.

The number at the right of the parameter indicates the location in the 4-up display.

- 1=Upper left
2=Lower left
3=Upper right
4=Lower right

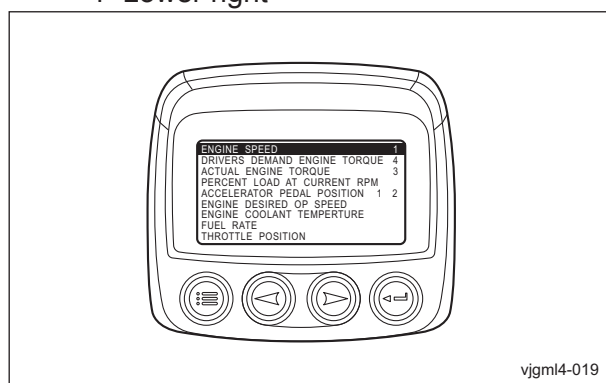

vjgml4-019

Custom Setup_005

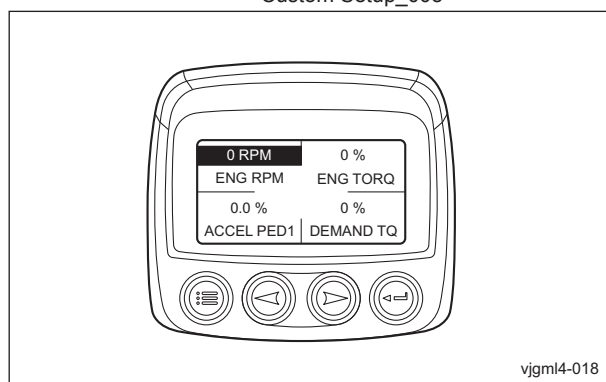

vjgml4-018

Custom Setup_006

- [4] To change to a different parameter
a. Use the arrow keys to highlight the parameter to be selected, and then press the Enter key.

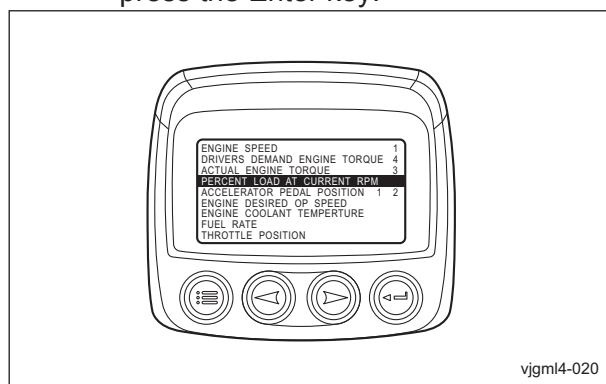

vjgml4-020

Custom Setup_007

Handling Instructions

b. Check that a number appeared to the right of the selected parameter.

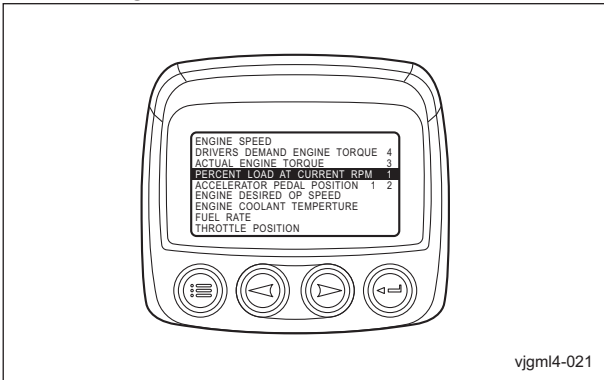

Custom Setup_008

b. Check that the number at the right of the parameter disappeared.

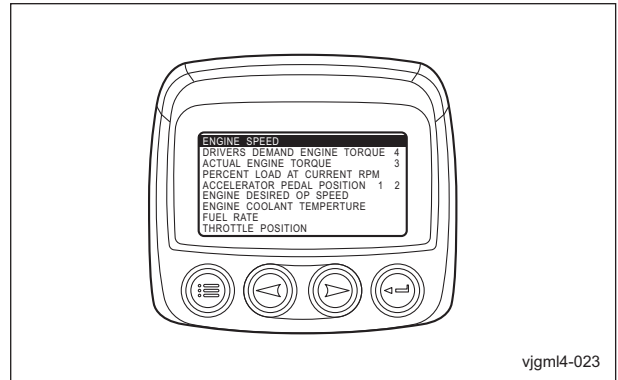

Custom Setup_011

c. Press the menu key and check that the parameter has changed.

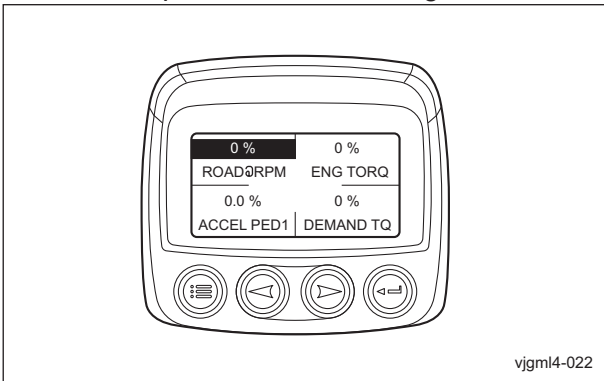

Custom Setup_009

c. Press the menu key and check that the parameter has changed to "EMPTY".

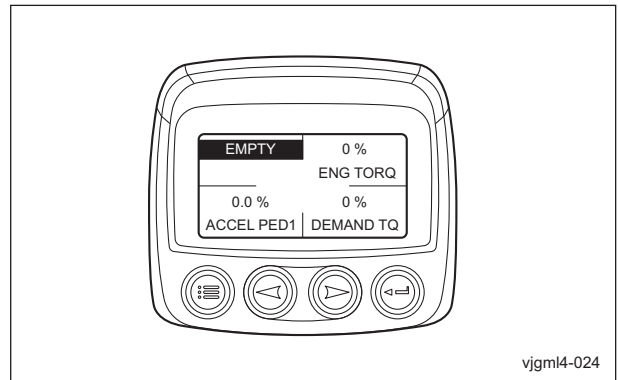

Custom Setup_012

[5] To deselect a parameter and remove it from the list of displayed parameters

a. Highlight the parameter to be removed, and then press the Enter key.

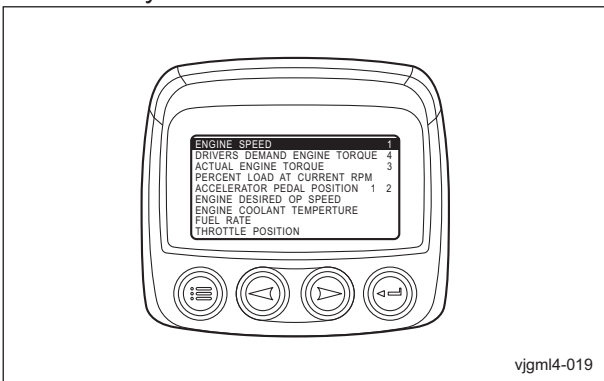

Custom Setup_010

5. Pressing the menu key once returns to the display for selecting the page.

6. To change other parameters, repeat steps 3 to 5.

Service Reminders

With "SERVICE REMINDERS", the notification of replacement time for the following 5 consumables can be specified.

- Engine oil
- Engine oil filter
- Hydraulic oil
- Hydraulic oil filter
- Air cleaner

The following 2 items appear when "SERVICE REMINDERS" is selected.

- RESET REMINDERS
- MODIFY REMINDERS

Handling Instructions

Reset Reminders

With "RESET REMINDER", displayed remaining time can be reset to the time specified with "MODIFY REMINDERS".

1. Press the menu key.

After the main menu appears, use the arrow keys to highlight "SERVICE REMINDERS", and then press the Enter key.

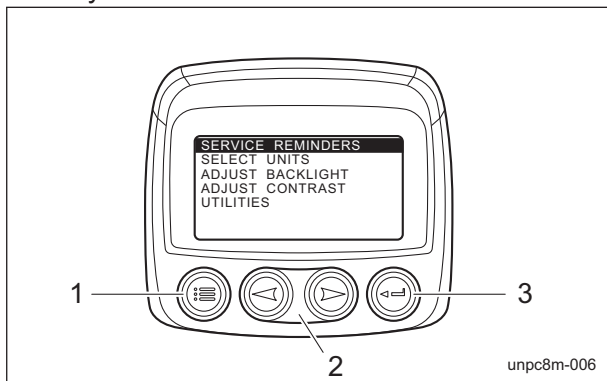

Reset Reminders_001

1	Menu key
2	Arrow keys
3	Enter key

2. Highlight "RESET REMINDER", and then press the Enter key.

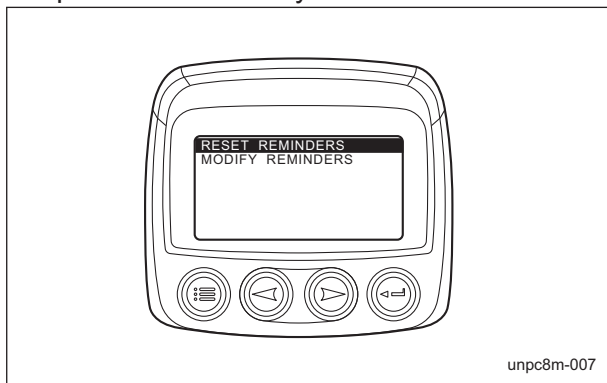

Reset Reminders_002

3. Use the arrow keys to highlight the item to be changed, and then press the Enter key. A plus appears at the right of the currently selected items.

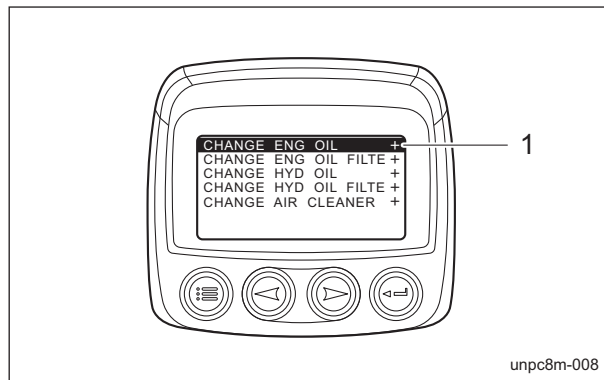

Reset Reminders_003

1	Plus
---	------

4. The remaining time for the selected item appears.

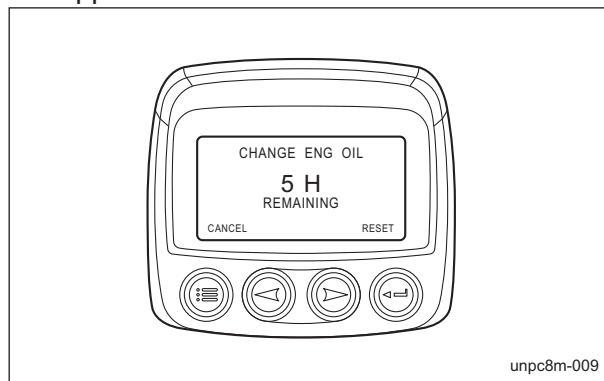

Reset Reminders_004

[1] To reset the remaining time to the specified time, press the Enter key.

[2] "RESET SERVICE REMINDER?" appears.

To reset, press the Enter key.

To cancel resetting, press the menu key.

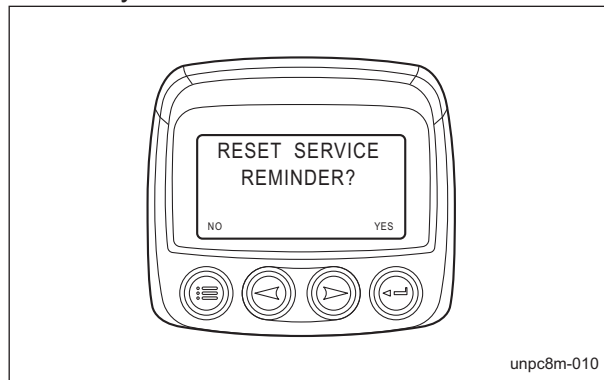

Reset Reminders_005

5. The screen for selecting the item appears.

Handling Instructions

■Modify Reminders

With "MODIFY REMINDERS", the replacement time period for consumables can be specified.

The factory default replacement time periods are the initial time periods.

Change the setting as necessary.

The replacement time period should be in accordance with the maintenance schedule.

Initial and regular time periods

	Initial time period	Regular time period
Engine oil	50 hrs.	400 hrs.
Engine oil filter	50 hrs.	400 hrs.
Hydraulic oil	100 hrs.	500 hrs.
Hydraulic oil filter	100 hrs.	500 hrs.
Air cleaner	600 hrs.	600 hrs.

1. Press the menu key.

After the main menu appears, use the arrow keys to highlight "SERVICE REMINDERS", and then press the Enter key.

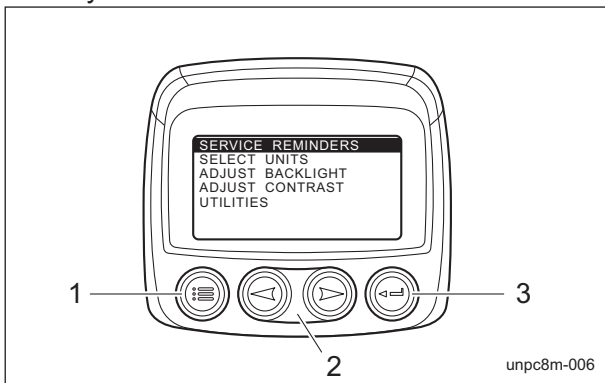

Modify Reminders_001

1	Menu key
2	Arrow keys
3	Enter key

2. Highlight "MODIFY REMINDERS", and then press the Enter key.

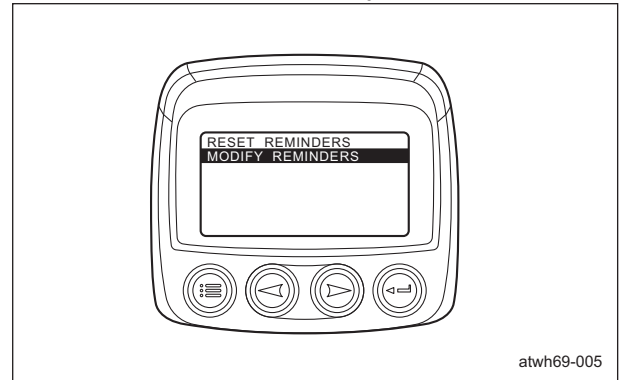

Modify Reminders_002

3. Use the arrow keys to highlight the item to be changed, and then press the Enter key. A plus appears at the right of the currently specified items.

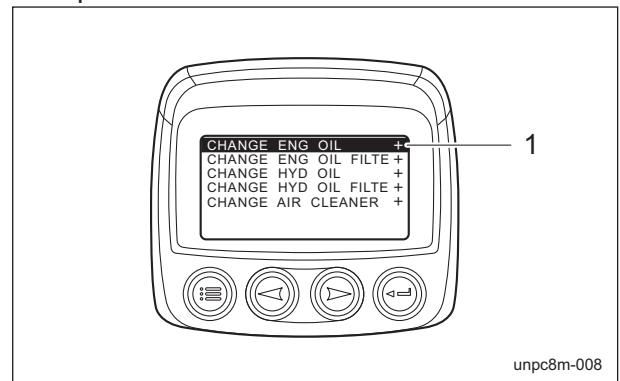

Modify Reminders_003

1	Plus
---	------

4. The replacement time period for the selected item appears.

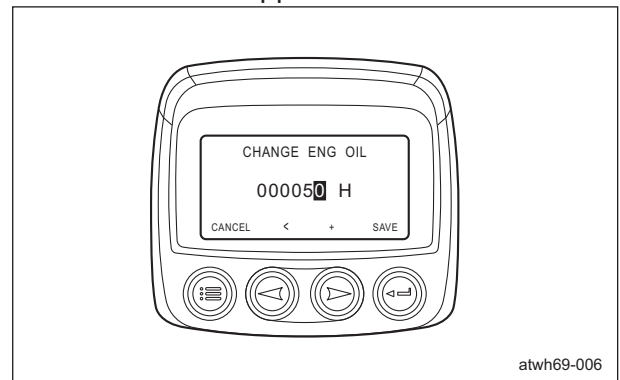

Modify Reminders_004

Handling Instructions

- Highlight the digit to be changed.
Press the right arrow key to increase the number. Press the left arrow key to change the digit.

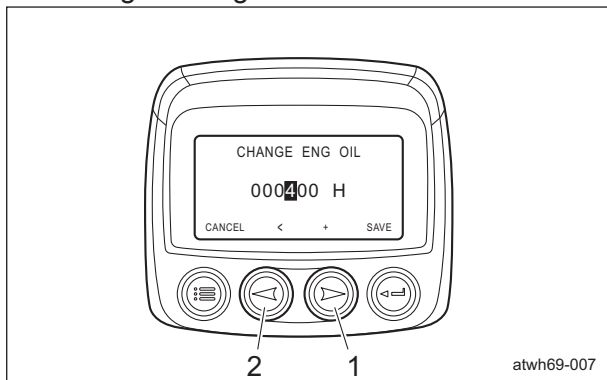

Modify Reminders_005

1	Right arrow key
2	Left arrow key

- To save the specified time period, press the Enter key.
- "MODIFY SERVICE REMINDER?" appears.
To save the changes, press the Enter key. To cancel the changes, press the menu key.

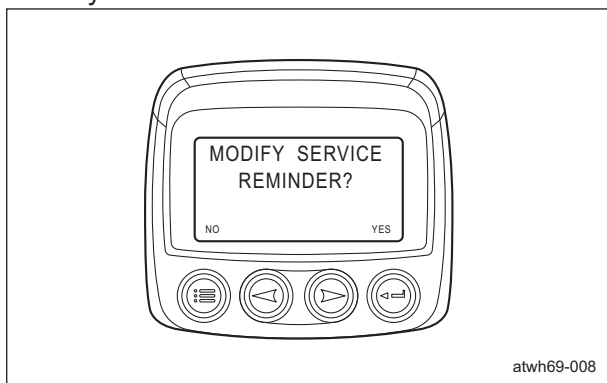

Modify Reminders_006

- The display for selecting the item appears.

■Reminder Display

Important

If a warning message appears, immediately stop operation, and then perform the replacement procedure.

- When the specified replacement time period for a consumable has passed, a warning message appears in the monitor display and the LED (yellow) lights up.

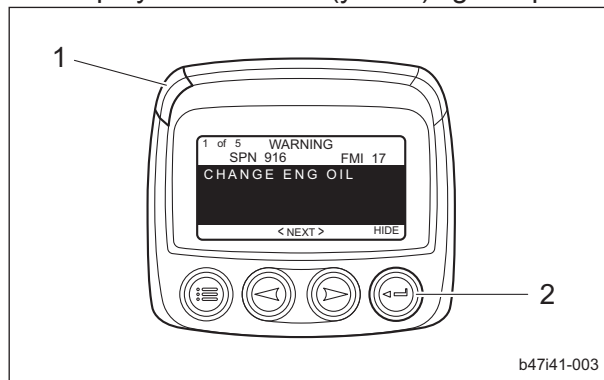

Reminder Display_001

1	LED (yellow)
2	Enter key

- Pressing the Enter key changes the screen from the warning message to the parameter display.
- A warning mark appears in the upper-right corner of the monitor display.

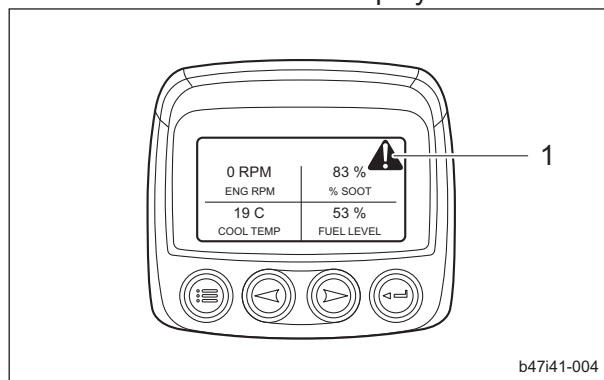

Reminder Display_002

1	Warning mark
---	--------------

- Change the replacement time period of consumables with "RESET REMINDERS" or "MODIFY REMINDERS".
When the replacement time period is changed, the warning message and mark disappear.

Handling Instructions

Select Units

With "SELECT UNITS", the units of parameter values can be set to any of the following three formats.

- ENGLISH
- METRIC KPA
- METRIC BAR

An asterisk appears at the right of the currently selected unit.

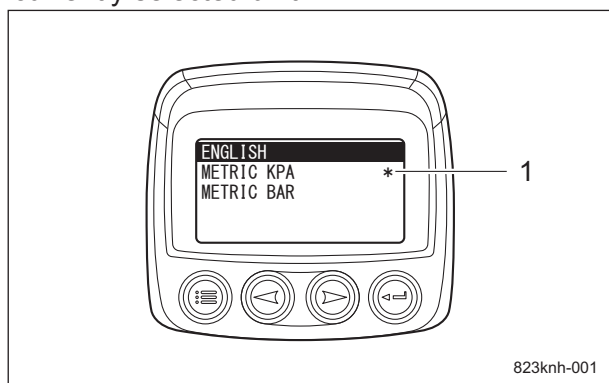

Select Units_001

1	Asterisk
---	----------

Monitor display S	Units		
	ENGLISH	METRIC KPA	METRIC BAR
ENG RPM	RPM	RPM	RPM
DEMAND TQ	%	%	%
ENG TORQ	%	%	%
LOAD@RPM	%	%	%
ACCEL PED1	%	%	%
DES ENG SP	RPM	RPM	RPM
COOL TEMP	F	C	C
FUEL RATE	G/HR	L/HR	L/HR
THROTTLE	%	%	%
BST PRES	PSI	kPa	BAR
MANI TEMP	F	C	C
BAT VOLT	VDC	VDC	VDC
BARO PRES	PSI	kPa	BAR
AMB TEMP	F	C	C
AIR IN TP	F	C	C
FUEL USED	Gal	L	L
ENG HRS	H	H	H
OIL PRES	PSI	kPa	BAR
RAIL PRES	PSI	kPa	BAR
AIR RATE	Gal	L	L
DOC TEMP	F	C	C
EF IN T	F	C	C
DIFF PRES	PSI	kPa	BAR
EF OUT T	F	C	C
%SOOT	%	%	%
MACH HRS	H	H	H
FUEL LEVEL	%	%	%

Note:

The factory default unit is "METRIC KPA".

Handling Instructions

Adjust Backlight

With "ADJUST BACKLIGHT", the brightness of the monitor display can be adjusted. Press the right arrow key to make the display brighter. Press the left arrow key to make the display darker.

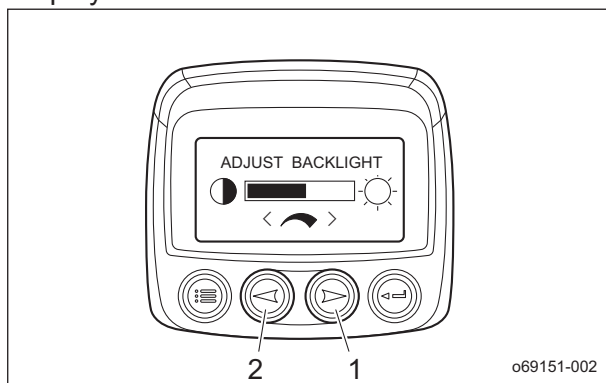

Adjust Backlight_001

1	Right arrow key
2	Left arrow key

Adjust Contrast

With "ADJUST CONTRAST", the contrast of the monitor display can be adjusted. Press the right arrow key to decrease the contrast. Press the left arrow key to increase the contrast.

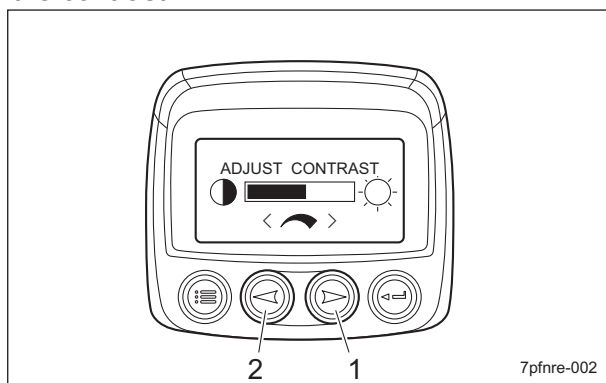

Adjust Contrast_001

1	Right arrow key
2	Left arrow key

Utilities

With "UTILITIES", the remaining fuel volume can be specified and the monitor configuration can be displayed.

The following 6 items appear when "UTILITIES" is selected.

- GAGE DATA
- REMOVE ALL GAGES

- SOFTWARE VERSION
- FAULT CONVERSION
- ANALOG INPUT
- OEM

Note:

"GAGE DATA" and "REMOVE ALL GAGES" are not supported on this machine.

■ Software Version

With "SOFTWARE VERSION", the software version of the monitor can be displayed.

■ Fault Conversion

With "FAULT CONVERSION", the J1939 fault code conversion method can be specified.

The monitor normally detects J1939 version 4.

Since the engine ECU of this machine uses J1939 version 4, no adjustments are necessary.

■ Analog Input

With "ANALOG INPUT", remaining fuel volume information can be specified. The following 2 items appear when "ANALOG INPUT" is selected.

- BACKLIGHT DIMMER
- FUEL LEVEL

Important

"BACKLIGHT DIMMER" is not supported on this machine.

Always select "FUEL LEVEL".

If "BACKLIGHT DIMMER" is selected, "NO DATA" appears as the value for the fuel level parameter.

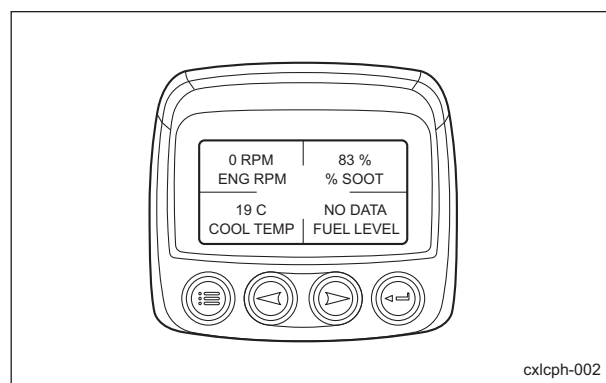

Analog Input_001

Note:

The factory default analog input is "FUEL LEVEL".

Handling Instructions

1. Fuel Level

With "FUEL LEVEL", the low fuel level can be specified.

1. Press the menu key.

After the main menu appears, use the arrow keys to highlight "UTILITIES", and then press the Enter key.

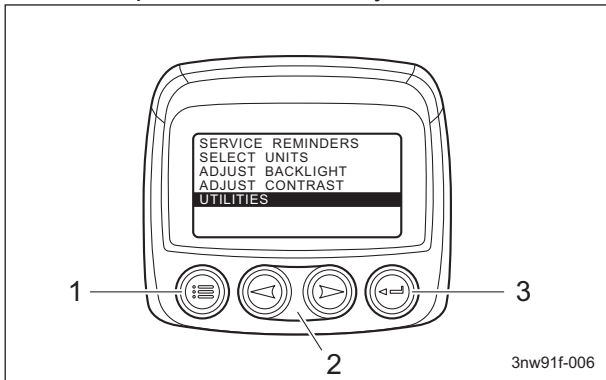

Fuel Level_001

1	Menu key
2	Arrow keys
3	Enter key

2. Highlight "ANALOG INPUT", and then press the Enter key.

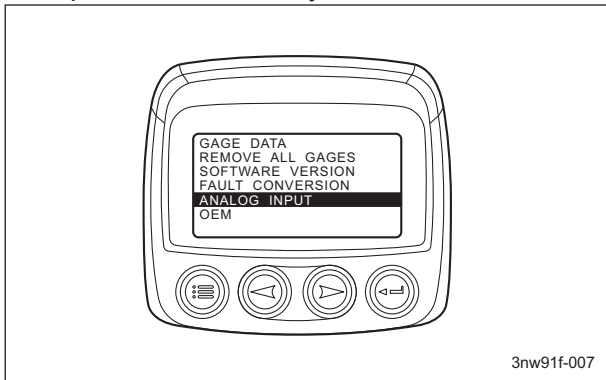

Fuel Level_002

3. Highlight "FUEL LEVEL", and then press the Enter key.

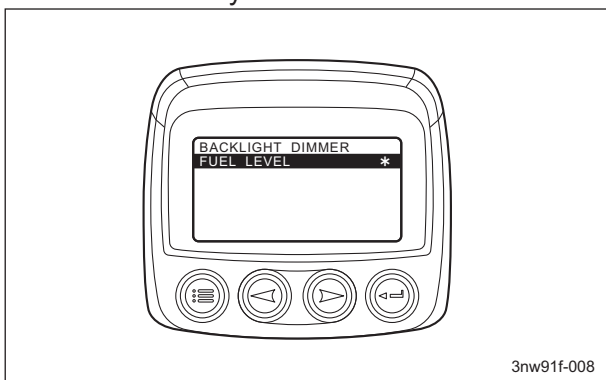

Fuel Level_003

4. Highlight "SET LOW FUEL LEVEL", and then press the Enter key.

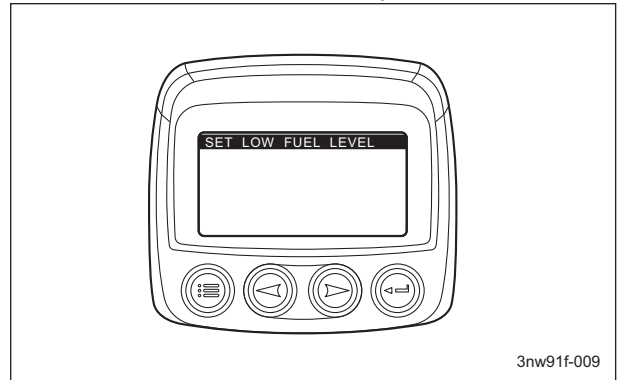

Fuel Level_004

5. "LOW FUEL" appears.

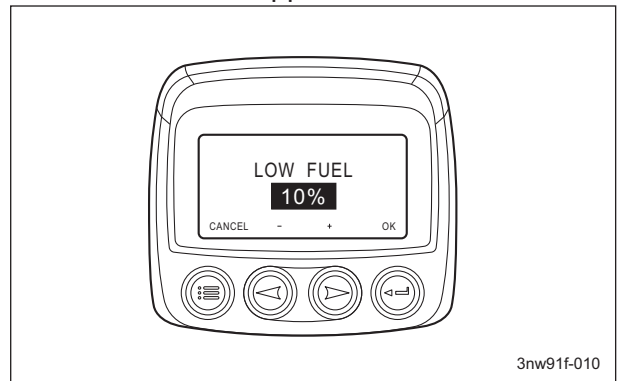

Fuel Level_005

6. Press the right arrow key to increase the value. Press the left arrow key to decrease the value.

The value can be set between 10% and 80% in 5% increments.

7. To save the specified value, press the Enter key.

Note:

The factory default low fuel level is 10%.

Handling Instructions

2. Low Fuel Level Display

Caution

If a warning message appears, immediately stop operation, and then supply fuel.

1. When the fuel level falls below the specified low fuel level, a warning message appears in the monitor display and the LED (yellow) lights up. The warning message appears on two pages.

Use the arrow keys to change the page.

• Text 1

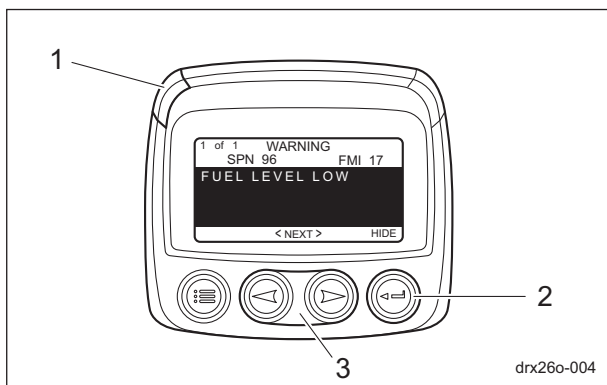

Low Fuel Level Display_001

1	LED (yellow)
2	Enter key
3	Arrow keys

• Text 2

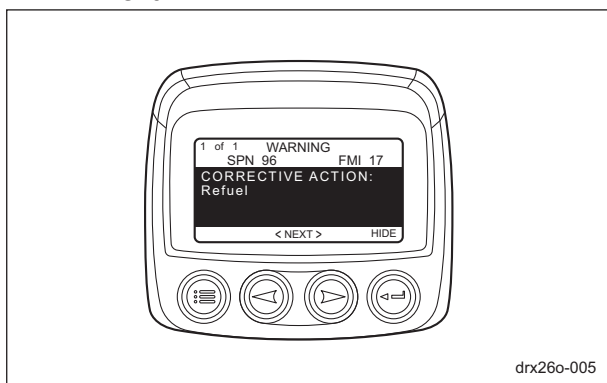

Low Fuel Level Display_002

2. Pressing the Enter key changes the screen from the warning message to the parameter display.

3. A warning mark appears in the upper-right corner of the monitor display.

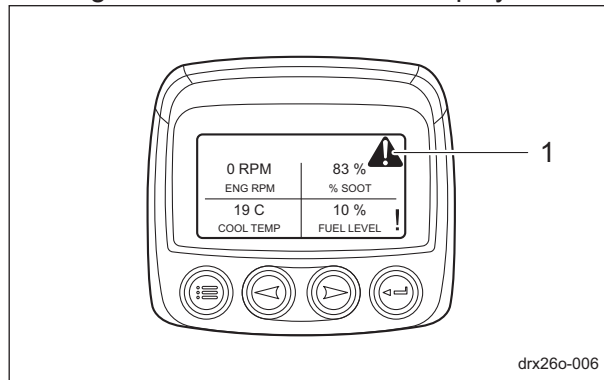

Low Fuel Level Display_003

1	Warning mark
---	--------------

4. When fuel is supplied to bring the fuel level above the specified low fuel level, the warning message and mark disappear.

■OEM

"OEM" is used when the manufacturer specifies factory default settings.

Important

No adjustments by the operator are necessary.

Handling Instructions

Fault Code Displays

Important

When the fault code (DTC) appears in the monitor display, contact your dealer.

A fault code (DTC) appears in the monitor display when a failure occurs on the function of engine.

Each fault code is displayed over two pages. Use the arrow keys to change the page.

- Text 1

The fault code name appears.

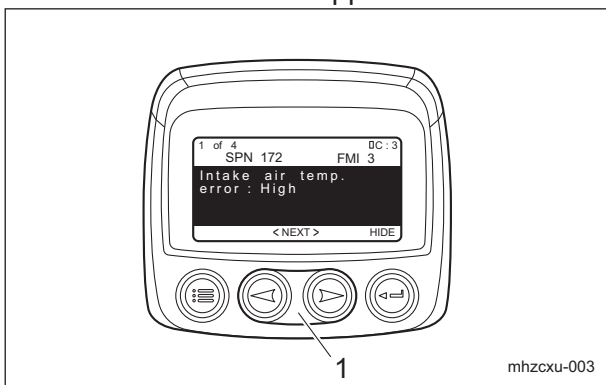

Fault Code Displays_001

1	Arrow keys
---	------------

- Text 2

The corrective action appears.

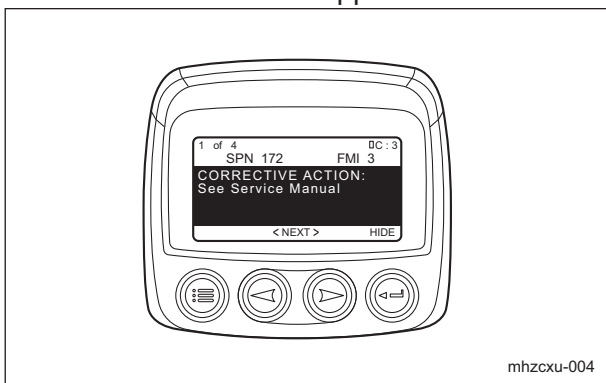

Fault Code Displays_002

Pressing the Enter key changes the screen from the fault code to the parameter display.

Important

If the service reminders are configured, the notices of the replacement time period for consumables and the fault code may appear all together.

If the low fuel level is specified, the notices of fuel level low and the fault code may appear all together.

If "ACTIVE FAULTS - ECU" message appears, check both the service reminder warning message and the fault code (DTC).

To check the service reminder warning message:

Highlight the service reminder notice, and then press the Enter key.

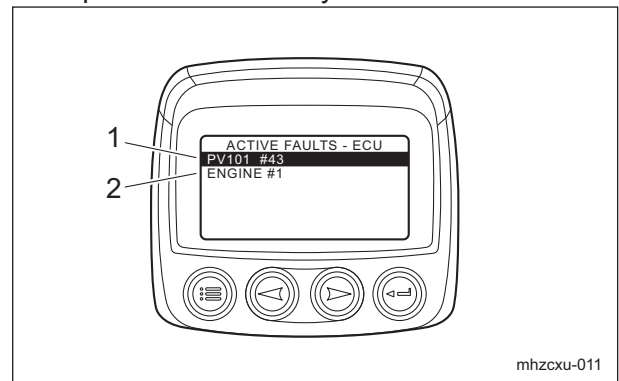

Fault Code Displays_003

1	Service reminder notice
2	Fault code notice

- Text 1

The item of requiring replacement of consumables appears.

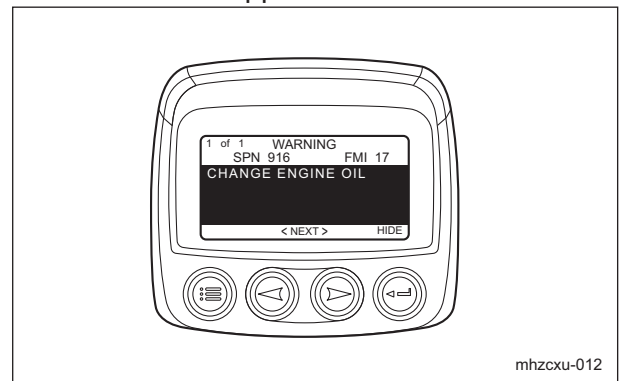

Fault Code Displays_004

Handling Instructions

- Text 2
The corrective action appears.

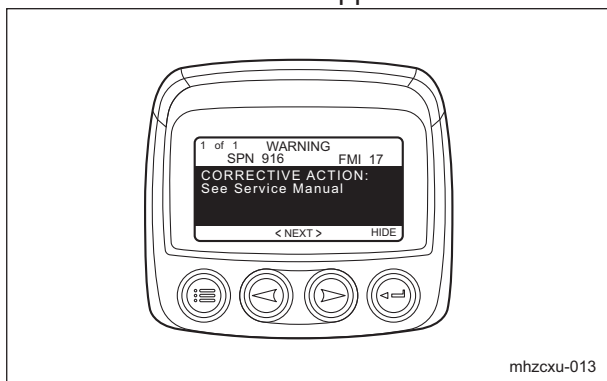

Fault Code Displays_005

To check the fault code (DTC):
Highlight the fault code notice, and then press the Enter key.

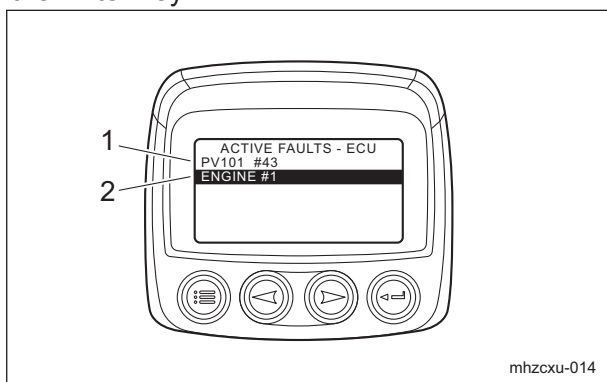

Fault Code Displays_006

1	Service reminder notice
2	Fault code notice

- Text 1
The fault code (DTC) name appears.

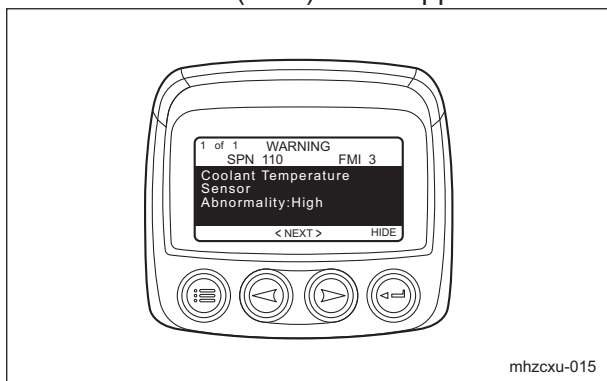

Fault Code Displays_007

- Text 2
The corrective action appears.

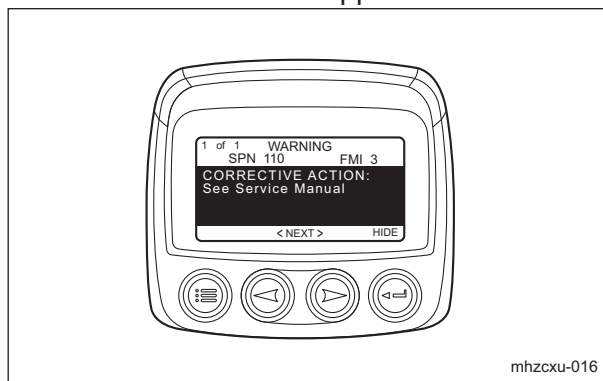

Fault Code Displays_008

Note:
If the warning message of service reminder ignored and the Enter key pressed to hide the message, the monitor will display "ACTIVE FAULTS - ECU".
If the fault code (DTC) ignored and the Enter key pressed, the monitor will also display "ACTIVE FAULTS - ECU".
If the notice ignored and the menu key pressed when the monitor displays "ACTIVE FAULTS - ECU", the warning mark continues to be displayed in the upper right corner of the monitor display.
To check the warning message and the fault code (DTC) again, press the Enter key to return to the display of "ACTIVE FAULTS - ECU".

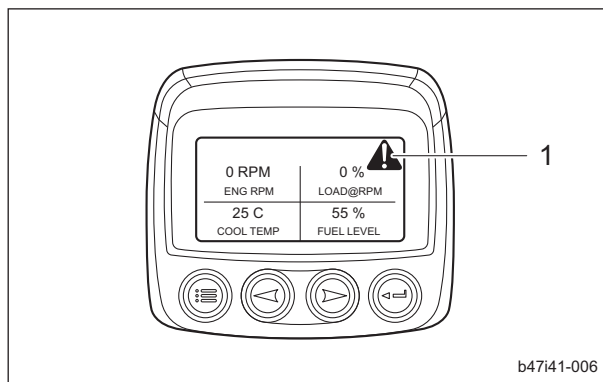

Fault Code Displays_009

1	Warning mark
---	--------------

Handling Instructions

Engine Warning Lamp

Important

Make repairs immediately if the fault codes of PCD (Particulate Control Diagnostic) and NCD (NOx Control Diagnostic) appear.

Engine warning lamp (LED) lights up or blinks when a failure occurs on the function of engine. Check the fault code (DTC) in the monitor display.

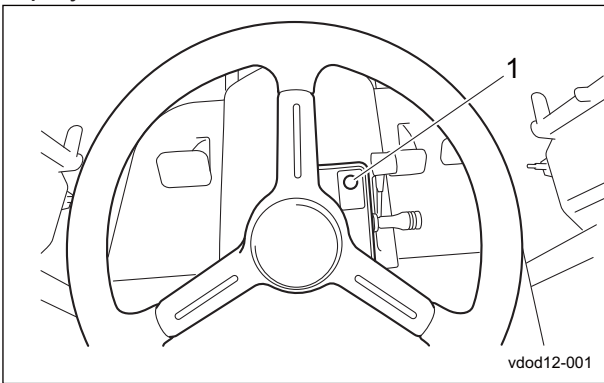

Engine Warning Lamp_001

1	Engine warning lamp
---	---------------------

The lighting patterns of engine warning lamp are as follows.

Note :

PCD means fault codes relevant to Particulate Control Diagnostic.

NCD means fault codes relevant to NOx Control Diagnostic.

1. Engine warning lamp lights up when only DTC other than PCD/NCD come up.

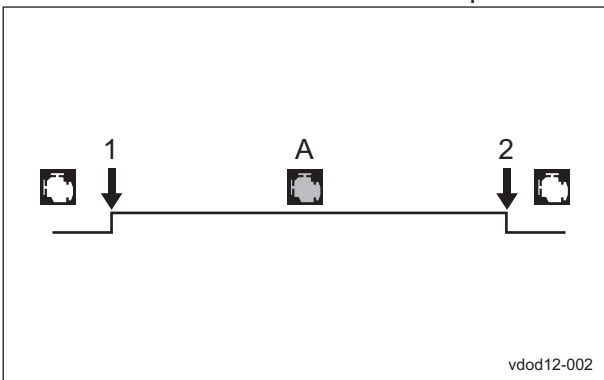

Engine Warning Lamp_002

1	Fault detected
2	Recovery
A	Lighting

2. Engine warning lamp blinks when only DTC relevant to PCD/NCD come up.

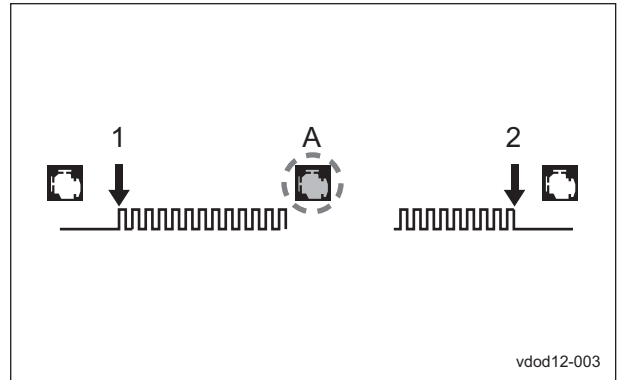

Engine Warning Lamp_003

1	Fault detected
2	Recovery
A	Blinking

3. Engine warning lamp repeats blinking and lighting alternately when DTC relevant to/ other than PCD/NCD come up at the same time. (It repeats blinking three times and lighting three seconds.)

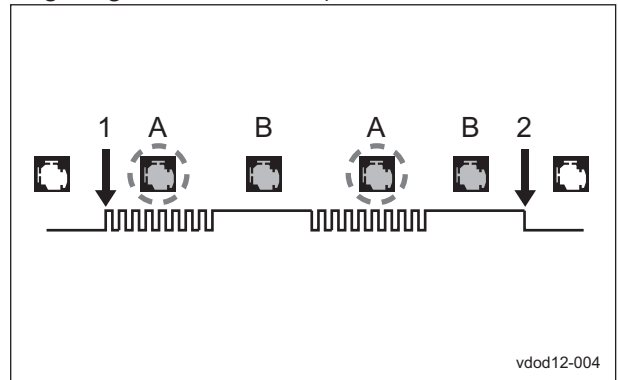

Engine Warning Lamp_004

1	Fault detected
2	Recovery
A	Blinking
B	Lighting

Handling Instructions

Travel of Machine

Moving The Machine

⚠ Caution

Under any circumstances drive the machine at such a speed that you can stop it immediately for emergencies.

⚠ Caution

When traveling, be sure to stop the reel cutters and raise the mower units.

1. Start the engine.
"Procedure to Start Engine" (Page 4-22)
2. Raise all mower units, and then engage the mower lock levers (latches) for mower units #4 and #5.
3. Depress the brake pedal to release the parking brake.
4. Slowly depress the traveling pedal.
5. The machine starts traveling.

Towing The Machine

If the machine does not travel due to engine trouble, etc., you can move it by towing it.

⚠ Caution

Before towing, check that the brake is applied effectively.

⚠ Caution

Before starting the engine, be sure to close the unload valves.

Important

Do not touch the unload valve except when towing the machine.

Important

When towing the machine, travel at a speed no more than 3.0 km/h.
In addition, do not tow the machine for more than 3 minutes.
If the towing speed is too fast or there is excessive movement, the pump or motor will be damaged.

1. Stop the engine.
"Procedure to Stop Engine" (Page 4-23)
2. Apply the parking brake.
3. Chock the wheels.
4. Secure the machine with ropes.

Front left side

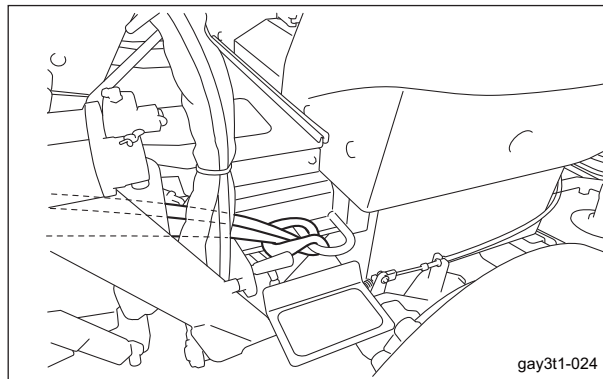

Towing The Machine_001

Front right side

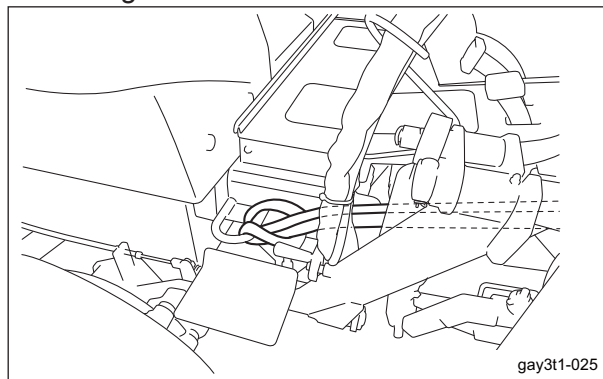

Towing The Machine_002

Rear side

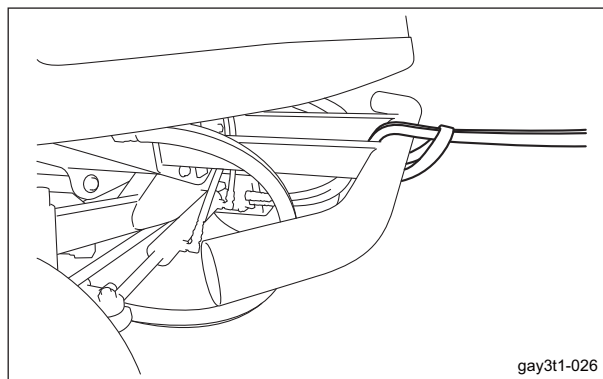

Towing The Machine_003

5. Set the 2WD/4WD selector switch to the "2WD" position.
6. Make sure that the steering wheel is raised completely, and then bring the seat to the backmost position.

Handling Instructions

7. Pull up the lever behind the seat to unlock it, and then tilt the seat forward to open the cover.

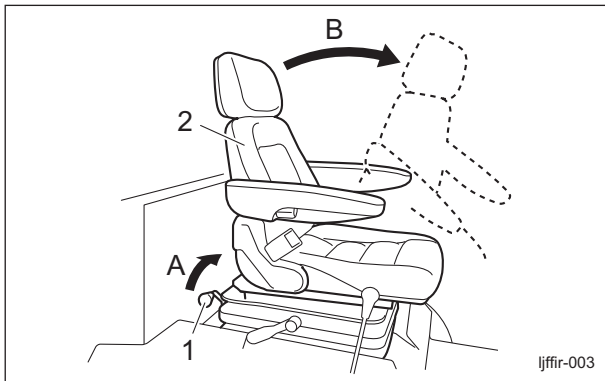

Towing The Machine_004

1	Lever
2	Seat
A	Pull up
B	Tilt forward

8. Turn the unload valve, located beside the hydraulic pump, 90 degrees (so that it is vertical) to open it.

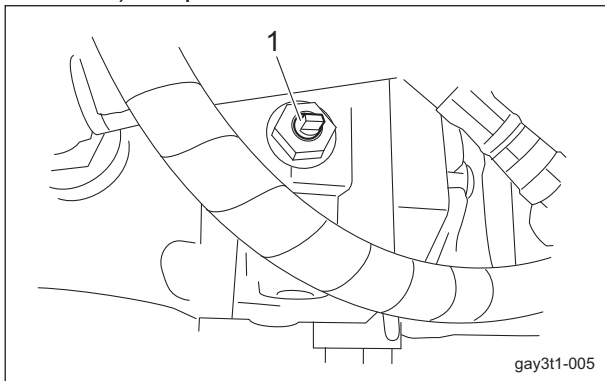

Towing The Machine_005

1	Unload valve
---	--------------

9. Replace the seat and close the cover.
 10. Remove the wheel stopper.
 11. Depress the brake pedal to release the parking brake.

Warning

While towing, always keep your foot on the brake pedal and depress the brake pedal at any time to stop.

12. Tow the machine slowly.

Cutting Work

Cutting Work

Warning

Do not start to move or stop the machine abruptly. To do so is very dangerous. In addition, it may damage the hydraulic system or result in oil leakage.

Caution

Be sure to operate at an appropriate speed for the mowing site.

When cutting over bumpy surfaces, keep the engine rpm steady, and slow down the cutting speed.

Caution

Note that if you stop operating the mower unit up/down lever before the mower units are raised completely, reel rotation may not stop. Reel rotation will be turned on or off based on the sensor-detected position of the mower units.

- Release the mower lock levers (latches) for mower units #4 and #5.
- Start the engine.
"Procedure to Start Engine" (Page 4-22)
- Raise all mower units.
- Firmly depress the brake pedal to release the locking pedal for releasing the locked brake pedal.
- Shift the throttle knob to rev the engine up to the maximum rpm.
- Shift the mower unit up/down lever to the "Down" position to lower the mower units.
- Set the reel rotation switch to the "Rotation" position to rotate the reel cutters (cutting cylinders) of all mower units.
- Depress the traveling pedal to start cutting work.

Note:

During the work, the reel cutters (cutting cylinders) will rotate or stop in sync with the up and down motion of the mower units.

Transporting

Transporting Procedure

When loading the machine into a trailer or a truck to transport it, drive the machine forward. When unloading, drive the machine in reverse. If the roof is installed on the machine, remove it.

The roof may be damaged by wind pressure.

Storage

Before Long-Term Storage

- Remove dirt, grass clippings, debris, oil stains etc. completely.
- Supply oil and apply grease to appropriate parts.
- Remove the negative terminal of the battery.

Handling Instructions

Maintenance Precautions	Page 5-2	Change of Engine Oil	Page 5-43
Maintenance Schedule	Page 5-2	Replacement of Engine Oil Filter	Page 5-44
Adjusted Value	Page 5-7	Replacement of Fuel Filter	Page 5-44
DPF	Page 5-8	Change of Fuse	Page 5-45
About DPF	Page 5-8		
DPF Regeneration	Page 5-8		
Replacement of DPF	Page 5-12		
Conditions for DPF Regeneration	Page 5-13		
PM Accumulation Level	Page 5-14		
Jacking Up The Machine	Page 5-19		
About Jacking Up The Machine	Page 5-19		
Jack-Up Points	Page 5-19		
Greasing	Page 5-20		
About Greasing	Page 5-20		
Greasing Points	Page 5-21		
Lubrication	Page 5-26		
About Lubrication	Page 5-26		
Lubricating Points	Page 5-27		
Maintenance Work	Page 5-29		
Cleaning of Mower Unit	Page 5-29		
Back Lapping	Page 5-29		
Sharpening of Reel Cutter (Cutting Cylinder)	Page 5-31		
Replacement of Reel Cutter (Cutting Cylinder)	Page 5-32		
Replacement of Bed Knife (Bottom Blade)	Page 5-33		
Swiveling Mower Units #2 and #3	Page 5-33		
Removing/Installing Tires	Page 5-34		
Adjustment of Belt Tension	Page 5-35		
Adjustment of Brake	Page 5-36		
Adjusting the Neutral Position of the Piston Pump	Page 5-37		
Change of Coolant	Page 5-38		
Change of Hydraulic Oil	Page 5-40		
Change of Hydraulic Oil Filter	Page 5-41		
Change of Air Cleaner	Page 5-42		

Maintenance

Maintenance Precautions

⚠ Caution

First, learn well the maintenance operations you plan to perform.

Important

Use tools appropriate for each maintenance operation.

Important

For the safe and best performance of your machine, use Baroness genuine parts for replacement and accessories.
Please note that our product warranty may be void if you use non-genuine parts for replacement or accessories.

Maintenance Schedule

LM3210A

Follow the maintenance schedule below.

- . . . Inspect, adjust, supply, clean
- . . . Replace (first time)
- △ . . . Replace

Maintenance Item		Before Work	After Work	Every Week	Every 50 hrs.	Every 100 hrs.	Every 250 hrs.	Every 400 hrs.	Every 500 hrs.	Every 800 hrs.	Every 1000 hrs.	Every 1500 hrs.	Every 3000 hrs.	Every month	Every year	Every 2 years	Every 4 years	When Required	Remarks
*4	Check engine oil level and contamination	○																	
*4	Check fuel level	○																	
*4	Check coolant level	○																	
*4	Check fan belt	○																	
	Check hydraulic oil level	○																	
	Check tire pressures and condition	○																	
	Check blade condition (Reel cutter and Bed knife)	○																	
	Check roller condition	○																	
	Engage blades	○																	
	Check mowing height	○																	
	Check interlock system safety function	○																	

Maintenance

Maintenance Item	Before Work	After Work	Every Week	Every 50 hrs.	Every 100 hrs.	Every 250 hrs.	Every 400 hrs.	Every 500 hrs.	Every 800 hrs.	Every 1000 hrs.	Every 1500 hrs.	Every 3000 hrs.	Every month	Every year	Every 2 years	Every 4 years	When Required	Remarks
Check oil or water leaks	<input type="radio"/>																	
Check cover condition	<input type="radio"/>																	
Check damaged parts	<input type="radio"/>																	
Check tightening bolts and nuts	<input type="radio"/>																	
Check brake function	<input type="radio"/>																	
Check hydraulic hoses condition	<input type="radio"/>																	
Clean machine exterior		<input type="radio"/>																
Clean engine area		<input type="radio"/>																
Open air cleaner evacuator valve to remove dust		<input type="radio"/>	<input type="radio"/>															Open valve every week or daily in dusty conditions
Clean radiator core		<input type="radio"/>																
Clean oil cooler core		<input type="radio"/>																
*4 Check fuel hoses and clamp bands				<input type="radio"/>														
*4 Draining of water separator				<input type="radio"/>														
Grease and Lubricate all moving parts				<input type="radio"/>														
Grease rear mower unit swing out pins				<input type="radio"/>														
Check CR brush condition				<input type="radio"/>														only if fitted
Clean inside of CR brush belt cover				<input type="radio"/>														only if fitted
Check and Adjust brakes				<input type="radio"/>														
Grease mower unit hydraulic motor shafts						<input type="radio"/>												
Grease cutting reel pivot pins (Axis bolt)								<input type="radio"/>										
*4 Clean air cleaner outer element (Replace the element after 6-time cleaning)					<input type="radio"/>									<input type="radio"/>				Replace every 6 cleanings or every year whichever comes earlier Air cleaner should be cleaned more often in dusty

Maintenance

Maintenance Item		Before Work	After Work	Every Week	Every 50 hrs.	Every 100 hrs.	Every 250 hrs.	Every 400 hrs.	Every 500 hrs.	Every 800 hrs.	Every 1000 hrs.	Every 1500 hrs.	Every 3000 hrs.	Every month	Every year	Every 2 years	Every 4 years	When Required	Remarks
*4	Clean air cleaner outer element (Replace the element after 6-time cleaning)					○									△				conditions than in normal conditions
	Replace hydraulic oil					●			△										100 hours first change, every 500 hours thereafter
	Replace hydraulic oil filter					●			△										100 hours first change, every 500 hours thereafter
*5	Check exterior of battery					○								○					Check every 100 hours or every month whichever comes earlier
*5	Clean exterior of battery					○								○					Check every 100 hours or every month whichever comes earlier
*5	Check mounting bracket of battery					○								○					Check every 100 hours or every month whichever comes earlier
*5	Check looseness and corrosion of battery terminals					○								○					Check every 100 hours or every month whichever comes earlier
*5	Check battery fluid level					○								○					Check every 100 hours or every month whichever comes earlier
*4	Adjust fan belt tension					○													
*4	Check radiator hoses and clamp bands						○												
*4	Check intake air line (air cleaner hose)						○								○				Check every 250 hours or every year whichever comes earlier

Maintenance

Maintenance Item		Before Work	After Work	Every Week	Every 50 hrs.	Every 100 hrs.	Every 250 hrs.	Every 400 hrs.	Every 500 hrs.	Every 800 hrs.	Every 1000 hrs.	Every 1500 hrs.	Every 3000 hrs.	Every month	Every year	Every 2 years	Every 4 years	When Required	Remarks
*1	Replace fuel filter cartridge							△											
*4	Change engine oil				●			△							△				Initial 50 hours, thereafter every 400 hours or every year whichever comes earlier
*4	Replace oil filter cartridge				●			△							△				Initial 50 hours, thereafter every 400 hours or every year whichever comes earlier
*4	Clean water separator								○										
*2.*4	Clean fuel tank interior								○										
*2.*4	Clean water jacket and radiator interior								○										
*2.*4	Replace fan belt								△							△			Replace every 500 hours or 2 years whichever comes earlier
	Replace hydraulic suction filter								△										
*2.*4	Check valve clearance									○									
*2.*3.* 4	Check injector											○							
*2.*3.* 4	Check EGR cooler											○							
*3.*4	Replace oil separator element											△							
*2.*3.* 4	Check PCV (Positive Crankcase Ventilation) Valve in the oil separator body											○							
*2.*3.* 4	Check turbocharger												○						
*2.*3.* 4	Replace DPF filters												△						
*2.*3.* 4	Check EGR system											○							
	Check electrical wiring condition (Damage,														○				

Maintenance

Maintenance Item		Before Work	After Work	Every Week	Every 50 hrs.	Every 100 hrs.	Every 250 hrs.	Every 400 hrs.	Every 500 hrs.	Every 800 hrs.	Every 1000 hrs.	Every 1500 hrs.	Every 3000 hrs.	Every month	Every year	Every 2 years	Every 4 years	When Required	Remarks
	defacement and joint looseness)														○				
*2.*4	Replace air cleaner inner element														△				The secondary (inner) element should be removed only if it is to be replaced.
*2.*4	Check DPF differential pressure pipes and hoses														○				
*2.*4	Check EGR piping														○				
*4	Check exhaust manifold (Crack, gas leakage and mounting screw)														○				
*2.*4	Replace oil separator rubber hose															△			
*2.*4	Replace rubber hose of DPF differential pressure sensor															△			
*2.*4	Replace intake hose (After air flow sensor) and inter cooler hose															△			
*2.*4	Replace rubber hose of boost pressure sensor															△			
*2.*4	Replace EGR cooler hose															△			
*2.*4	Replace water hose															△			
*2.*4	Replace lubricant hose															△			
*4	Change radiator coolant (L.L.C.)															△			
*2.*4	Replace radiator hoses and clamp bands															△			
*1.*2.*4	Replace fuel hoses and clamps															△			
*2.*4	Replace intake air line (air cleaner hose)															△			
	Replace hydraulic hoses (Moving part)															△			
	Replace hydraulic hoses (Fixed part)																△		
	Backlap blades																	○	
	Replace brake pads																		△

Maintenance

Maintenance Item	Before Work	After Work	Every Week	Every 50 hrs.	Every 100 hrs.	Every 250 hrs.	Every 400 hrs.	Every 500 hrs.	Every 800 hrs.	Every 1000 hrs.	Every 1500 hrs.	Every 3000 hrs.	Every month	Every year	Every 2 years	Every 4 years	When Required	Remarks	
Replace brake cables																		△	
Regrind blades (Reel cutter)																		○	Grind/Replace blades as and when required
*5 Replace battery																		△	

- *1: When biodiesel fuel is used, change the fuel filter cartridge, fuel hose and clamp bands with new ones at intervals half of the usual ones.
- *2: Consult your local Baroness Dealer or local KUBOTA Dealer for this service.
- The items above (*3 marked) are registered as emission related critical parts by KUBOTA in the U.S. EPA nonroad emission regulation.
As the engine owner, you are responsible for the performance of the required maintenance on the engine according to the above instruction.
Please see the Engine's Warranty Statement in detail.
- The items listed above other than *3 marked are not necessary to keep the emission-related warranty valid.
- Failure to perform the maintenance will cause problems that will significantly degrade the engine performance.
- *4: Refer to the Engine's Owner's Manual.
- *5: Refer to the Battery's Owner's Manual.
- The values for consumables are not guaranteed.
- Replace the steering cylinder hoses every 2 years.

Adjusted Value

Cutter adjustment spring	40.0 mm (1.575 in)	Coil spring length
CR brush	0 - 1.0 mm (0 - 0.039 in)	Gap between brush and rear roller
Fan belt	7.0 - 9.0 mm (0.28 - 0.35 in)	Belt slack
CR brush drive belt	5.0 - 6.0 mm (0.197 - 0.236 in)	Slack with 10.0 N (1.0 kgf) force applied around center section between belt pulleys
Brake	0.2 mm (0.0079 in)	Clearance between the brake disc and the pad
	1.0 mm (0.039 in)	Play at the connection of the inner wire

Maintenance

DPF

About DPF

The DPF is a purifying filter that collects PM (soot) from exhaust gas.

When a certain amount of PM (soot) has accumulated, DPF regeneration must be performed automatically or manually in order to restore the filtering function.

DPF Regeneration

Danger

Since it will become extremely hot around the exhaust outlet during DPF regeneration, do not perform the regeneration in a location where fires may occur.

Caution

Do not use "DPF Auto Regeneration Inhibit Switch" and "DPF Parked Regeneration Switch" during back lapping.

Important

When the system enters the level where DPF regeneration is required, perform the regeneration immediately. Interrupting the regeneration or ignoring the warning and continuing traveling or cutting work may cause the engine and DPF to malfunction.

Important

Do not repeat unnecessary regeneration or interrupting regeneration. If repeating them, the measured level of engine oil may increase since the engine oil is mixed with a slight amount of fuel, accompanied by quality degradation.

Important

Perform DPF regeneration when the engine sufficiently warmed up.

DPF regeneration is burning PM (soot) collected in DPF with the exhaust temperature heated up to high temperature by the engine ECU control of intake air mass and fuel injection.

Automatic Regeneration

Danger

Since it will become extremely hot around the exhaust outlet during DPF regeneration, do not perform the regeneration in a location where fires may occur.

Caution

Normally, set the DPF auto regeneration inhibit switch to the "Auto regeneration mode". However, when operating in a location where fires may occur, set the DPF auto regeneration inhibit switch to the "Auto regeneration inhibit mode".

Important

When the system enters the level where DPF regeneration is required, perform the regeneration immediately. Interrupting the regeneration or ignoring the warning and continuing traveling or cutting work may cause the engine and DPF to malfunction.

Automatic regeneration is the automatic control of increasing the exhaust temperature for DPF regeneration.

- You can continue to use this machine for traveling and cutting work during DPF regeneration.
- You can operate this machine to perform the regeneration. (The fault diagnostic tool is not required.)
- Automatic regeneration is activated only when the auto regeneration inhibit switch set to the "Auto regeneration mode".
- Automatic regeneration is activated when PM accumulation level is "Level 1" or "Level 2".
However, it may be activated in "Level 0" depending on the other condition.

Important

If the regeneration remains uncompleted even after 30 minutes have passed since the start of automatic regeneration in PM accumulation "Level 1", PM accumulation level enters "Level 2".

These are the procedures of automatic regeneration.

■ When the DPF auto regeneration inhibit switch set to the "Auto regeneration mode":

1. When the conditions for automatic regeneration are met, the automatic regeneration starts with the regeneration icon lighting.
2. When the regeneration completed, the regeneration icon disappears.

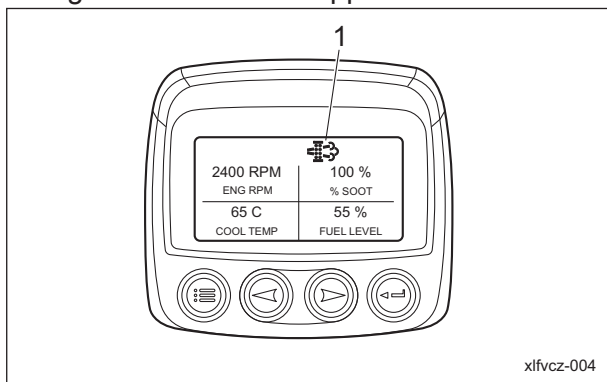

Automatic Regeneration_001

1	Regeneration icon
---	-------------------

■ When the DPF auto regeneration inhibit switch set to the "Auto regeneration inhibit mode":

1. When PM accumulation level enters "Level 1" or "Level 2", the blinking regeneration icon appears.
2. Set the DPF auto regeneration inhibit switch to the "Auto regeneration mode".
3. When the conditions for automatic regeneration are met, the automatic regeneration starts and the regeneration icon changes from blinking to lighting.
4. When the regeneration completed, the regeneration icon disappears.

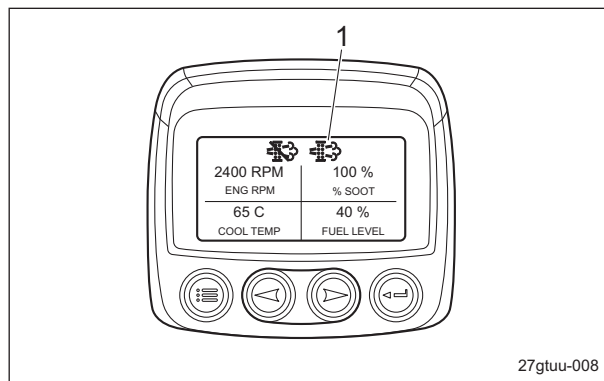

Automatic Regeneration_002

1	Regeneration icon
---	-------------------

Parked Regeneration**! Danger**

Since it will become extremely hot around the exhaust outlet during DPF regeneration, do not perform the regeneration in a location where fires may occur.

Important

When the system enters the level where DPF regeneration is required, perform the regeneration immediately.

Interrupting the regeneration or ignoring the warning and continuing traveling or cutting work may cause the engine and DPF to malfunction.

Parked regeneration is the DPF regeneration forcibly performed, parking this machine in a safe location, when auto regeneration does not reduce the amount of accumulated PM to the specified value.

- You can not continue to use this machine for traveling and cutting work during DPF regeneration.
- You can operate this machine to perform the regeneration. (The fault diagnostic tool is not required.)
- These are the conditions for activating parked regeneration.
 1. The parking brake is applied.
 2. The traveling pedal is in neutral.
 3. The throttle opening is 0% (idling).
- Parked regeneration is activated when PM accumulation level is "Level 1", "Level 2" or "Level 3".

Maintenance

Important

If the regeneration remains uncompleted in automatic regeneration, parked regeneration is required with the blinking regeneration icon.

■ In PM accumulation "Level 1" or "Level 2":

Important

If ignoring the parked regeneration requirement and continuing traveling or cutting work in PM accumulation "Level 1" or "Level 2", PM accumulation level enters "Level 2" or "Level 3".

Follow the steps below for parked regeneration.

1. When PM accumulation level enters "Level 1" or "Level 2", the blinking regeneration icon appears.

When the DPF auto regeneration inhibit switch set to the "Auto regeneration mode":

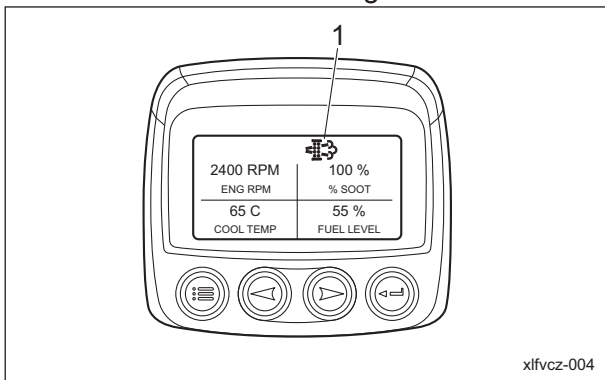

Parked Regeneration_001

1	Regeneration icon
---	-------------------

When the DPF auto regeneration inhibit switch set to the "Auto regeneration inhibit mode":

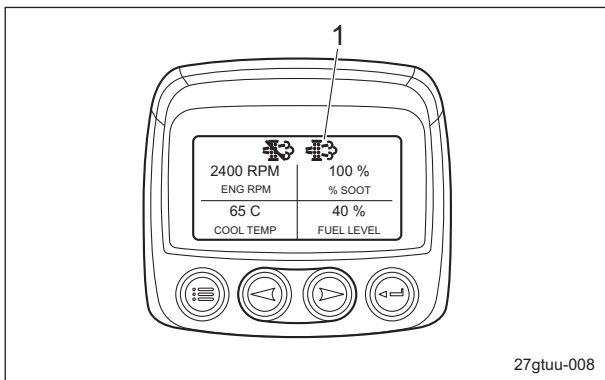

Parked Regeneration_002

1	Regeneration icon
---	-------------------

2. Stop traveling and cutting work.

3. Park this machine in a safe location.
4. Apply the parking brake.
5. Set the throttle opening to 0% (idling).
6. Press the DPF parked regeneration switch. Parked regeneration starts and the regeneration icon changes from blinking to lighting.
7. When the regeneration completed, the regeneration icon disappears.

■ In PM accumulation "Level 3":

Important

If ignoring the parked regeneration requirement and continuing traveling or cutting work in PM accumulation "Level 3", PM accumulation level enters "Level 4".

If still continuing traveling or cutting work, you will not be able to operate this machine for regeneration.

Important

Automatic regeneration can not be activated in PM accumulation "Level 3". Perform parked regeneration immediately.

1. These are the statuses in PM accumulation "Level 3".

- "Excessive PM3" appears in the monitor display. Pressing an arrow key changes the display to "CORRECTIVE ACTION: Start DPF Parked Regeneration immediately".
- The LED (yellow) lights up.
- The engine output is limited at 50%.

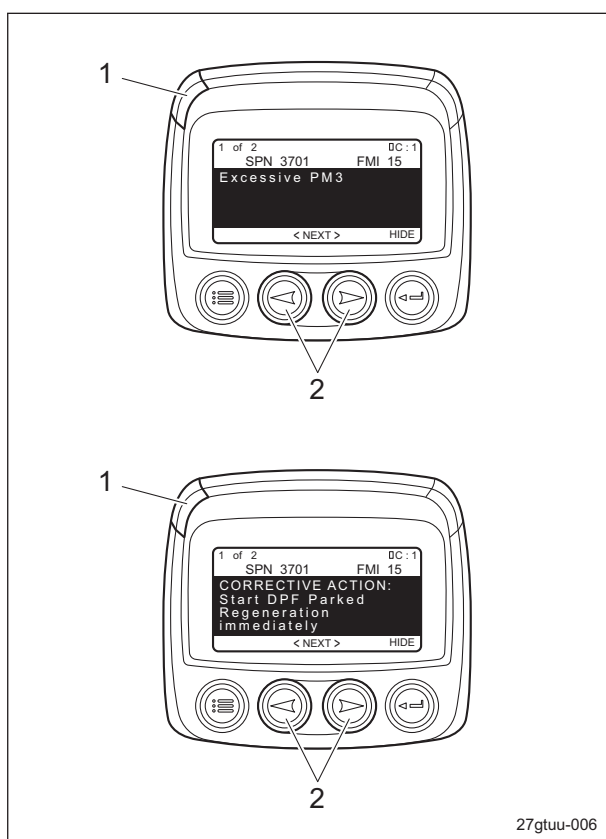

27gtuu-006

Parked Regeneration_003

1	LED (yellow)
2	Arrow key

2. Stop traveling and cutting work.
3. Park this machine in a safe location.
4. Apply the parking brake.
5. Set the throttle opening to 0% (idling).
6. Press the DPF parked regeneration switch. Parked regeneration starts and the regeneration icon changes from blinking to lighting.
7. When the regeneration completed, the regeneration icon disappears.

Manual Regeneration

⚠ Danger

Since it will become extremely hot around the exhaust outlet during DPF regeneration, do not perform the regeneration in a location where fires may occur.

Important

When the system enters the level where DPF regeneration is required, perform the regeneration immediately. Interrupting the regeneration or ignoring the warning and continuing traveling or cutting work may cause the engine and DPF to malfunction.

Manual regeneration is the DPF regeneration performed only by the expert with the fault diagnostic tool. Normal automatic regeneration or parked regeneration can not complete regeneration since large amount of PM accumulates.

Manual regeneration can be activated in any PM accumulation level.

- You can not continue to use this machine for traveling and cutting work during DPF regeneration.
- You can not perform the regeneration. (The fault diagnostic tool is required.)
- Manual regeneration is activated in PM accumulation "Level 4".
- Manual regeneration is activated in any PM accumulation level when the following condition met.
 1. when replacing DPF
 2. when replacing ECU

Maintenance

■ In PM accumulation "Level 4":

Important

If ignoring the manual regeneration requirement and continuing traveling or cutting work in PM accumulation "Level 4", PM accumulation level enters "Level 5". If still continuing traveling or cutting work, fatal trouble will occur on the engine and DPF.

1. These are the statuses in PM accumulation "Level 4".

- "Excessive PM4" appears in the monitor display.
- Pressing an arrow key changes the display to "CORRECTIVE ACTION: Stop engine!! Contact dealer immediately".
- The LED (yellow) lights up.
- The engine output is limited at 50%.

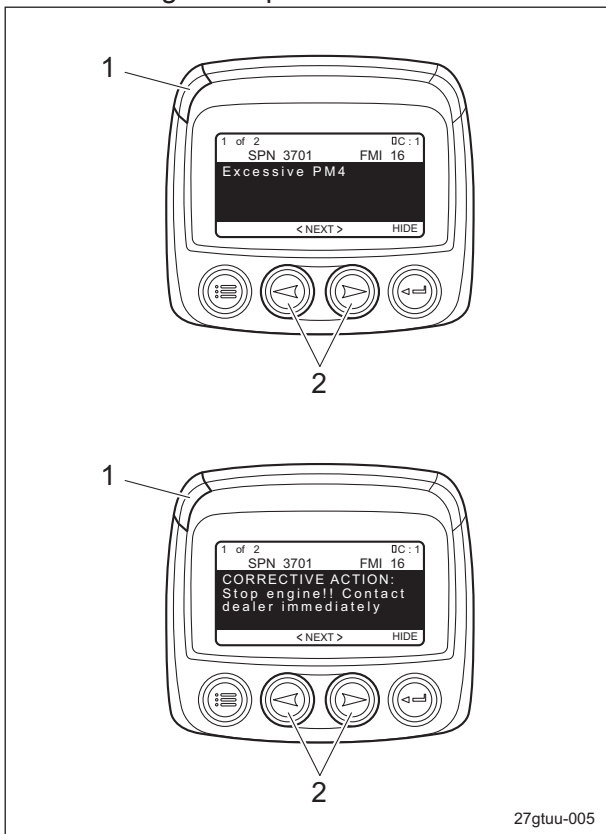

Manual Regeneration_001

1	LED (yellow)
2	Arrow key

2. Stop traveling and cutting work.
3. Park this machine in a safe location.
4. Apply the parking brake.
5. Stop the engine.

6. Contact your dealer for manual regeneration.

Replacement of DPF

When PM accumulates excessively in the DPF or ash accumulates, replace the DPF since the regeneration in that case is prohibited.

- You can not continue to use this machine for traveling and cutting work.
- The regeneration is impossible.
- Replace every 3,000 hours.
- Replace DPF in PM accumulation "Level 5" or "High frequency of regeneration".

■ In PM accumulation "Level 5":

1. These are the statuses in PM accumulation "Level 5".

- "Excessive PM5" appears in the monitor display.
- Pressing an arrow key changes the display to "CORRECTIVE ACTION: Stop engine!! Contact dealer immediately".
- The LED (red) lights up.
- The engine output is limited at 50%.

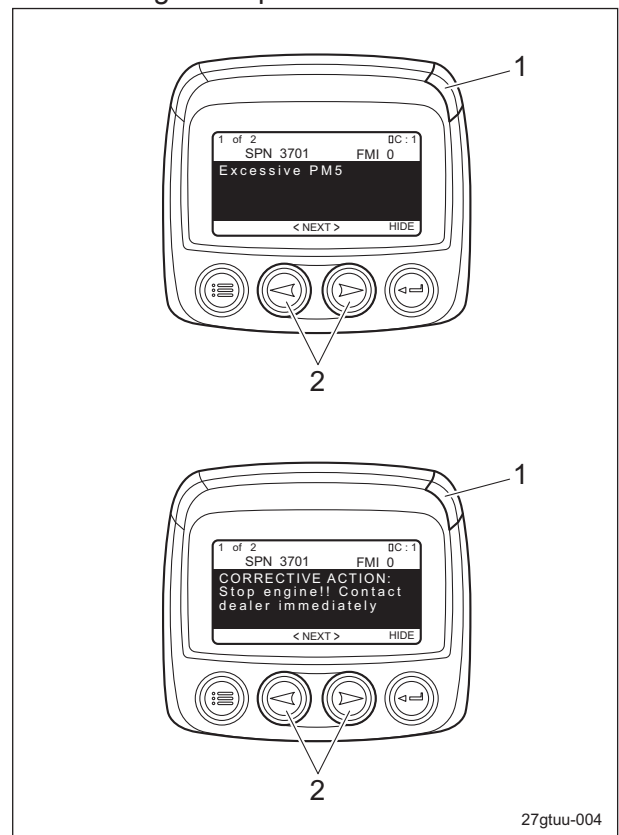

Replacement of DPF_001

1	LED (red)
2	Arrow key

2. Stop traveling and cutting work.

3. Park this machine in a safe location.
4. Apply the parking brake.
5. Stop the engine.
6. Contact your dealer for DPF replacement.

■ In the case of "High frequency of regeneration" :

1. These are the statuses in the case of "High frequency of regeneration".
 - "High frequency of regeneration" appears in the monitor display.
 - Pressing an arrow key changes the display to description of corrective action.
 - The LED (yellow) lights up.
 - The engine output is limited at 50%.

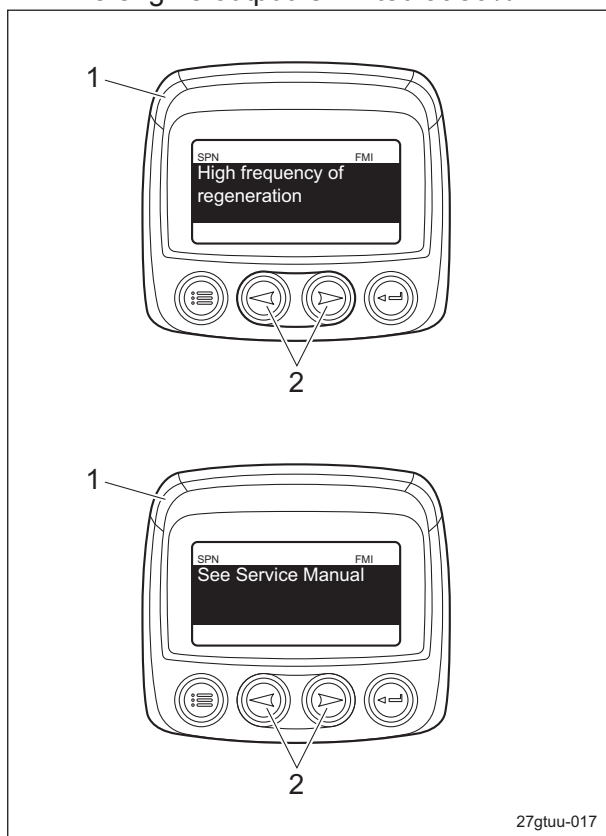

Replacement of DPF_002

1	LED (yellow)
2	Arrow key

2. Stop traveling and cutting work.
3. Park this machine in a safe location.
4. Apply the parking brake.
5. Stop the engine.
6. Contact your dealer for DPF replacement.

Conditions for DPF Regeneration

⚠ Danger

Since it will become extremely hot around the exhaust outlet during DPF regeneration, do not perform the regeneration in a location where fires may occur.

Important

If DPF regeneration is interrupted before it is completed, the next regeneration may be requested soon since not all of the PM (soot) was removed.

Important

Perform DPF regeneration when the engine sufficiently warmed up.

1. DPF auto regeneration does not begin unless both of the following two conditions are met.
 - The DPF auto regeneration inhibit switch is set to the "Auto regeneration mode". (Auto regeneration inhibit icon is turned off.)
 - The coolant temperature is 50 °C or more.
2. DPF parked regeneration and manual regeneration do not begin unless all of the following four conditions are met.
 - The parking brake is applied.
 - The traveling pedal is in the neutral position.
 - The throttle opening is 0% (idling).
 - The coolant temperature is 50 °C or more.
3. During DPF regeneration, the operation is canceled if any of the following conditions occur.
 - Any condition for starting regeneration is violated.
 - The ignition key is switched to the "OFF" position.

Maintenance

PM Accumulation Level

Level 0

DPF regeneration is not necessary.

Level 1

Danger

Since it will become extremely hot around the exhaust outlet during DPF regeneration, do not perform the regeneration in a location where fires may occur.

Caution

Normally, set the DPF auto regeneration inhibit switch to the "Auto regeneration mode". However, when operating in a location where fires may occur, set the DPF auto regeneration inhibit switch to the "Auto regeneration inhibit mode".

Important

When the system enters the level where DPF regeneration is required, perform the regeneration immediately. Interrupting the regeneration or ignoring the warning and continuing traveling or cutting work may cause the engine and DPF to malfunction.

Important

If the regeneration remains uncompleted even after 30 minutes have passed since the start of automatic regeneration in PM accumulation "Level 1", PM accumulation level enters "Level 2".

- You can continue to use this machine for traveling and cutting work during DPF regeneration.
- You cannot continue to use this machine for traveling and cutting work during DPF parked regeneration.
- You can operate this machine to perform the regeneration. (The fault diagnostic tool is not required.)

<Automatic regeneration>

■ When the DPF auto regeneration inhibit switch set to the "Auto regeneration mode":

1. When the conditions for automatic regeneration are met, the automatic regeneration starts with the regeneration icon lighting.
2. When the regeneration completed, the regeneration icon disappears.

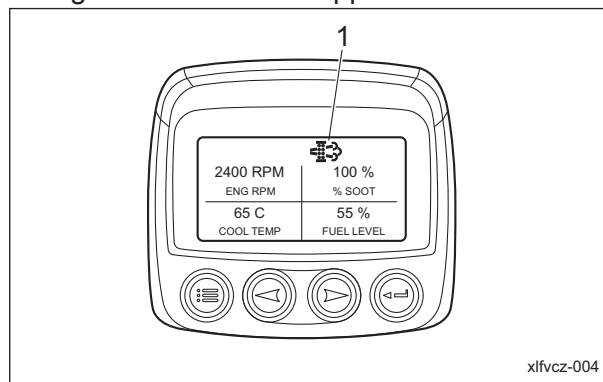

Level 1_001

1 Regeneration icon

■ When the DPF auto regeneration inhibit switch set to the "Auto regeneration inhibit mode":

1. The blinking regeneration icon appears.
2. Set the DPF auto regeneration inhibit switch to the "Auto regeneration mode".
3. When the conditions for automatic regeneration are met, the automatic regeneration starts and the regeneration icon changes from blinking to lighting.
4. When the regeneration completed, the regeneration icon disappears.

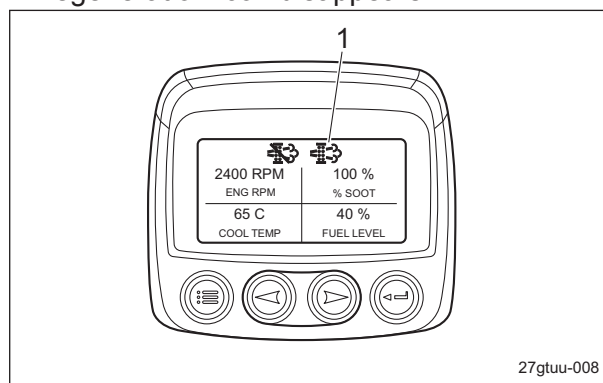

Level 1_002

1 Regeneration icon

<Parked regeneration>

- These are the conditions for activating parked regeneration.
 1. The parking brake is applied.
 2. The traveling pedal is in neutral.
 3. The throttle opening is 0% (idling).
- 1. The blinking regeneration icon appears.
When the DPF auto regeneration inhibit switch set to the "Auto regeneration mode":

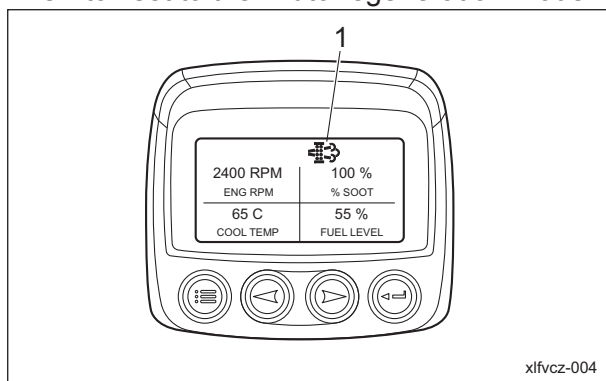

Level 1_003

1	Regeneration icon
---	-------------------

When the DPF auto regeneration inhibit switch set to the "Auto regeneration inhibit mode":

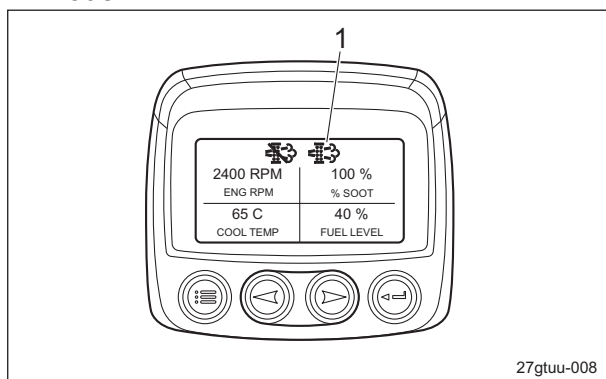

Level 1_004

1	Regeneration icon
---	-------------------

2. Stop traveling and cutting work.
3. Park this machine in a safe location.
4. Apply the parking brake.
5. Set the throttle opening to 0% (idling).
6. Press the DPF parked regeneration switch.
Parked regeneration starts and the regeneration icon changes from blinking to lighting.
7. When the regeneration completed, the regeneration icon disappears.

Level 2

! Danger

Since it will become extremely hot around the exhaust outlet during DPF regeneration, do not perform the regeneration in a location where fires may occur.

! Caution

Normally, set the DPF auto regeneration inhibit switch to the "Auto regeneration mode". However, when operating in a location where fires may occur, set the DPF auto regeneration inhibit switch to the "Auto regeneration inhibit mode".

Important

When the system enters the level where DPF regeneration is required, perform the regeneration immediately.

Interrupting the regeneration or ignoring the warning and continuing traveling or cutting work may cause the engine and DPF to malfunction.

Important

If ignoring the parked regeneration requirement and continuing traveling or cutting work in PM accumulation "Level 2", PM accumulation level enters "Level 3".

- You can continue to use this machine for traveling and cutting work during DPF auto regeneration.
- You can not continue to use this machine for traveling and cutting work during DPF parked regeneration.
- You can operate this machine to perform the regeneration. (The fault diagnostic tool is not required.)

<Automatic regeneration>

■ When the DPF auto regeneration inhibit switch set to the "Auto regeneration mode":

1. When the conditions for automatic regeneration are met, the automatic regeneration starts with the regeneration icon lighting.

Maintenance

2. When the regeneration completed, the regeneration icon disappears.

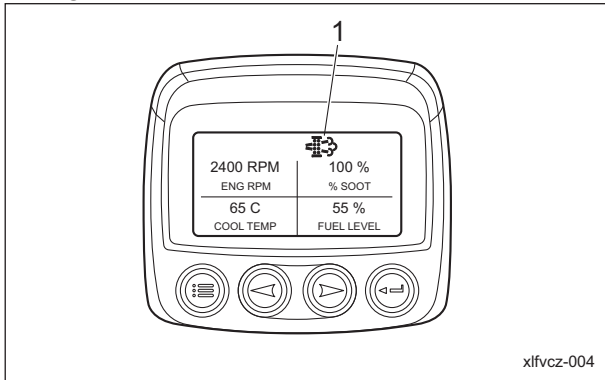

Level 2_001

1	Regeneration icon
---	-------------------

■ When the DPF auto regeneration inhibit switch set to the "Auto regeneration inhibit mode":

1. The blinking regeneration icon appears.
2. Set the DPF auto regeneration inhibit switch to the "Auto regeneration mode".
3. When the conditions for automatic regeneration are met, the automatic regeneration starts and the regeneration icon changes from blinking to lighting.
4. When the regeneration completed, the regeneration icon disappears.

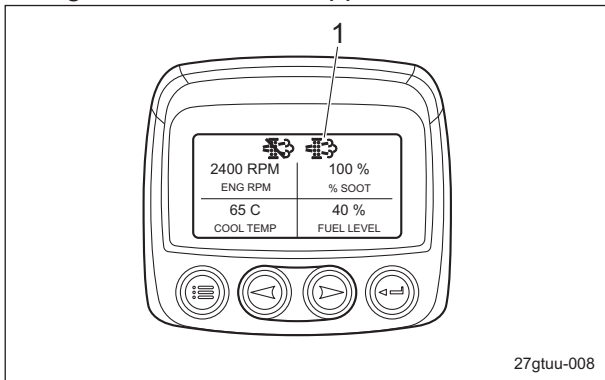

Level 2_002

1	Regeneration icon
---	-------------------

<Parked regeneration>

- These are the conditions for activating parked regeneration.

1. The parking brake is applied.
2. The traveling pedal is in neutral.
3. The throttle opening is 0% (idling).

1. The blinking regeneration icon appears. When the DPF auto regeneration inhibit switch set to the "Auto regeneration mode":

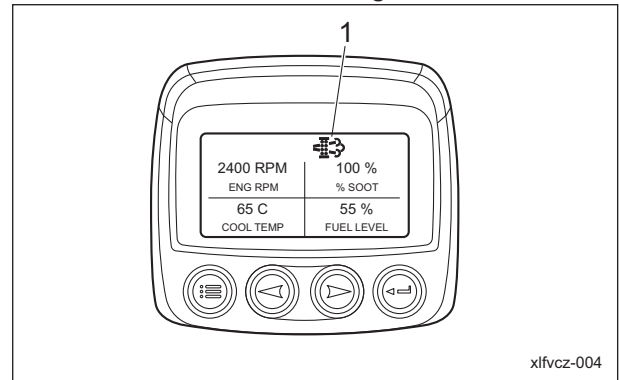

Level 2_003

1	Regeneration icon
---	-------------------

When the DPF auto regeneration inhibit switch set to the "Auto regeneration inhibit mode":

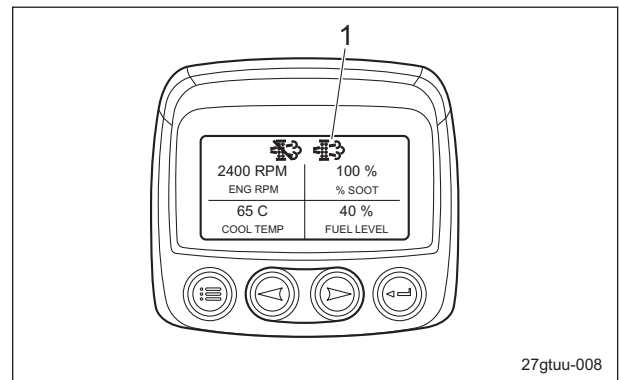

Level 2_004

1	Regeneration icon
---	-------------------

2. Stop traveling and cutting work.
3. Park this machine in a safe location.
4. Apply the parking brake.
5. Set the throttle opening to 0% (idling).
6. Press the DPF parked regeneration switch. Parked regeneration starts and the regeneration icon changes from blinking to lighting.
7. When the regeneration completed, the regeneration icon disappears.

Level 3

Danger

Since it will become extremely hot around the exhaust outlet during DPF regeneration, do not perform the regeneration in a location where fires may occur.

Important

When the system enters the level where DPF regeneration is required, perform the regeneration immediately. Interrupting the regeneration or ignoring the warning and continuing traveling or cutting work may cause the engine and DPF to malfunction.

Important

If ignoring the parked regeneration requirement and continuing traveling or cutting work in PM accumulation "Level 3", PM accumulation level enters "Level 4". If still continuing traveling or cutting work, you will not be able to operate this machine for regeneration.

Important

Automatic regeneration can not be activated in PM accumulation "Level 3". Perform parked regeneration immediately.

- You can not continue to use this machine for traveling and cutting work during DPF regeneration.
- You can operate this machine to perform the regeneration. (The fault diagnostic tool is not required.)

1. These are the statuses in PM accumulation "Level 3".

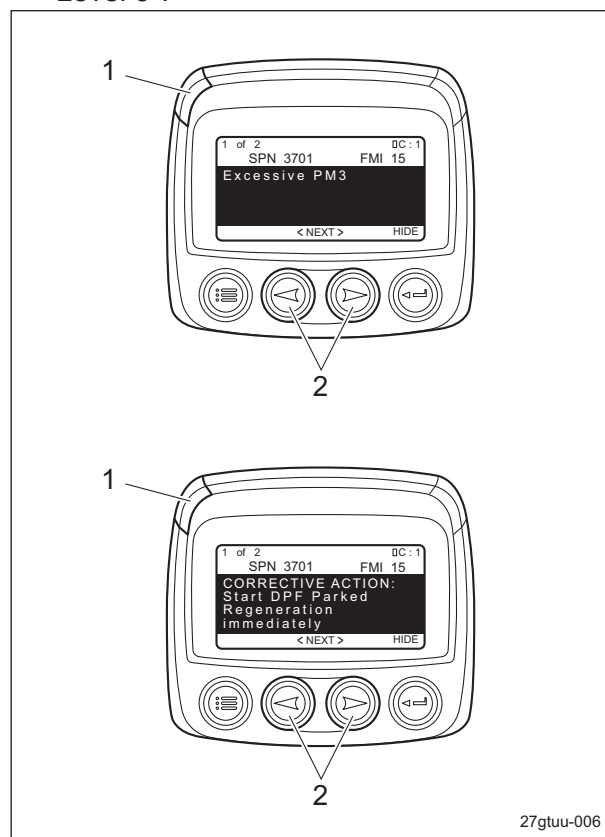

27gtuu-006

Level 3_001

1	LED (yellow)
2	Arrow key

- "Excessive PM3" appears in the monitor display. Pressing an arrow key changes the display to "CORRECTIVE ACTION: Start DPF Parked Regeneration immediately".
 - The LED (yellow) lights up.
 - The engine output is limited at 50%.
2. Stop traveling and cutting work.
 3. Park this machine in a safe location.
 4. Apply the parking brake.
 5. Set the throttle opening to 0% (idling).
 6. Press the DPF parked regeneration switch. Parked regeneration starts and the regeneration icon changes from blinking to lighting.
 7. When the regeneration completed, the regeneration icon disappears.

Maintenance

Level 4

Danger

Since it will become extremely hot around the exhaust outlet during DPF regeneration, do not perform the regeneration in a location where fires may occur.

Important

When the system enters the level where DPF regeneration is required, perform the regeneration immediately. Interrupting the regeneration or ignoring the warning and continuing traveling or cutting work may cause the engine and DPF to malfunction.

Important

If ignoring the manual regeneration requirement and continuing traveling or cutting work in PM accumulation "Level 4", PM accumulation level enters "Level 5". If still continuing traveling or cutting work, fatal trouble will occur on the engine and DPF.

- You can not continue to use this machine for traveling and cutting work during DPF regeneration.
- You can not perform the regeneration. (The fault diagnostic tool is required.)

1. These are the statuses in PM accumulation "Level 4".

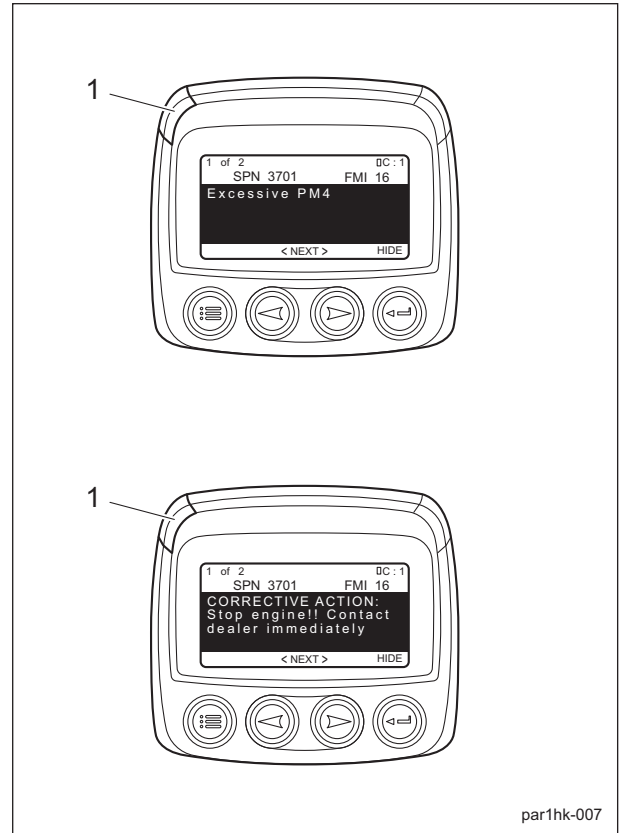

par1hk-007

Level 4_001

1	LED (yellow)
2	Arrow key

- "Excessive PM4" appears in the monitor display. Pressing an arrow key changes the display to "CORRECTIVE ACTION: Stop engine!! Contact dealer immediately".
 - The LED (yellow) lights up.
 - The engine output is limited at 50%.
2. Stop traveling and cutting work.
 3. Park this machine in a safe location.
 4. Apply the parking brake.
 5. Stop the engine.
 6. Contact your dealer for manual regeneration.

Level 5

When PM accumulates excessively in the DPF or ash accumulates, replace the DPF since the regeneration in that case is prohibited.

- You can not continue to use this machine for traveling and cutting work.
- The regeneration is impossible.

1. These are the statuses in PM accumulation "Level 5".

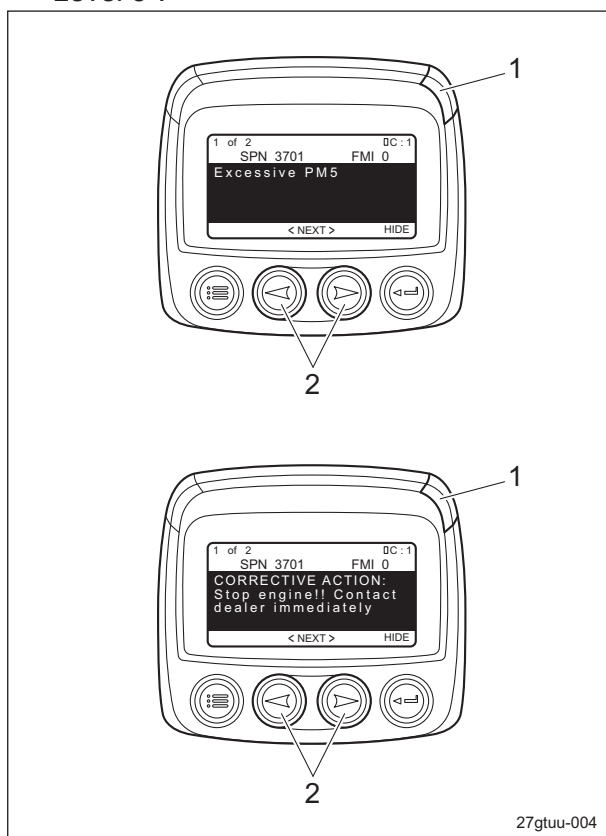

27gtuu-004

Level 5_001

1	LED (red)
2	Arrow key

- "Excessive PM5" appears in the monitor display.
Pressing an arrow key changes the display to "CORRECTIVE ACTION: Stop engine!! Contact dealer immediately".
 - The LED (red) lights up.
 - The engine output is limited at 50%.
2. Stop traveling and cutting work.
 3. Park this machine in a safe location.
 4. Apply the parking brake.
 5. Stop the engine.
 6. Contact your dealer for DPF replacement.

Jacking Up The Machine

About Jacking Up The Machine

Warning

When replacing a tire or beginning any other maintenance or repairs, be sure to chock the wheels to prevent the machine from moving. Before jacking up the machine, park it on a hard, flat surface such as a concrete floor and remove any obstacles that could prevent you from performing the work safely. When necessary, use an appropriate chain block, hoist, or jack. Support the machine securely with jack stands or appropriate blocks. Failure to do so may cause the machine to move or fall, resulting in injury or death.

Use the jack-up points identified in this manual when jacking up the machine.

Only place a jack under the jack-up points specified.

Placing a jack at any other point could result in damage to the frame or other parts.

Jack-Up Points

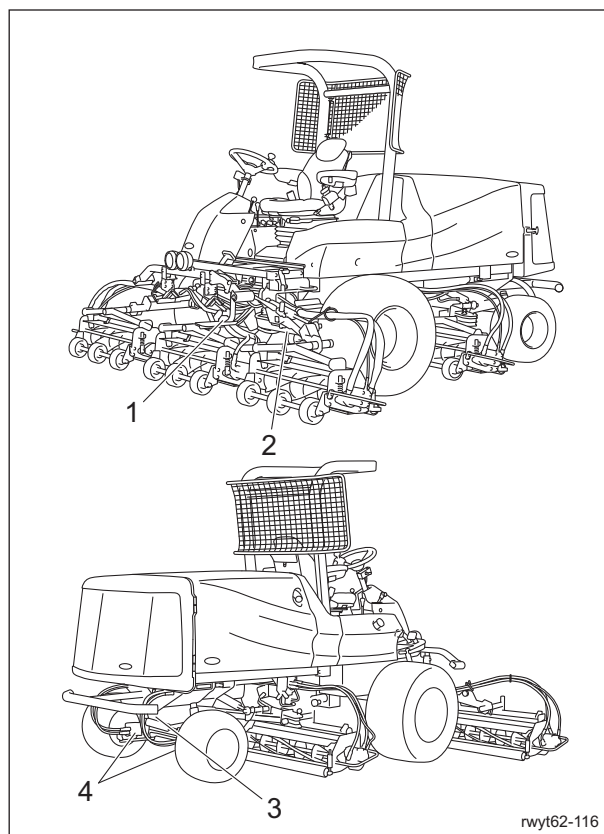

rwy162-116

Jack-Up Points_001

Maintenance

	Jack-up points
1	Front right frame
2	Front left frame
3	Center of pivot
4	Below rear wheel motors

1. Front right frame

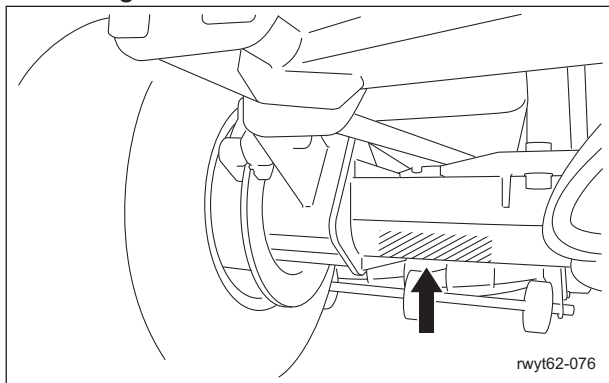

Jack-Up Points_002

2. Front left frame

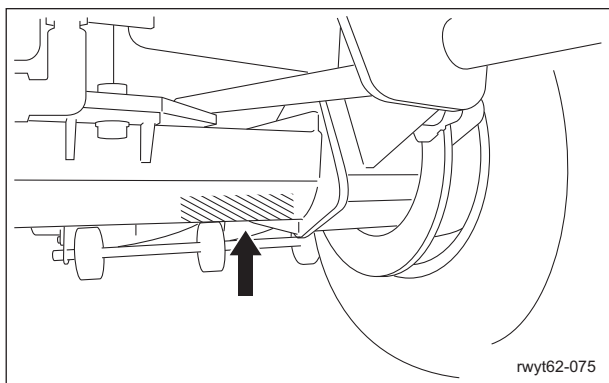

Jack-Up Points_003

3. Center of pivot

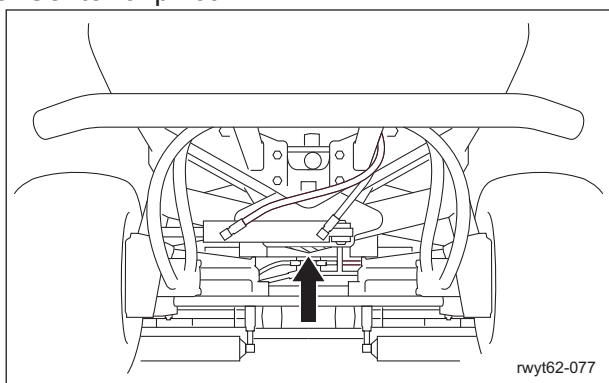

Jack-Up Points_004

4. Below rear wheel motors

There is one jack-up point below each rear wheel motor (left and right).

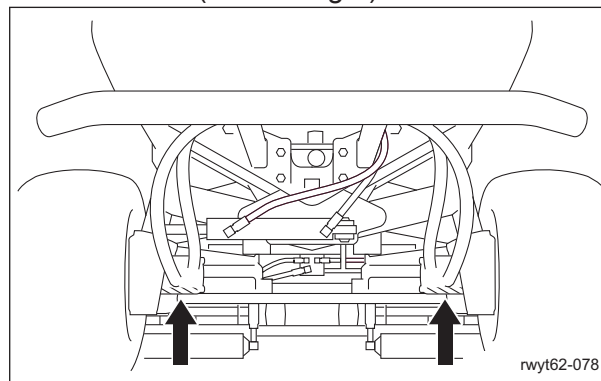

Jack-Up Points_005

Greasing

About Greasing

Since there may be adhesion or damage due to lack of grease on moving parts, they must be greased.

Add urea-based No. 2 grease in accordance with the Maintenance Schedule.

Other locations where the specified grease or lubricant is used are indicated in "Greasing Points".

Add grease using the specified grease or lubricant.

Greasing Points

Type_F

Grease nipples are installed in the following locations.

Add grease every 50 hours of operation.

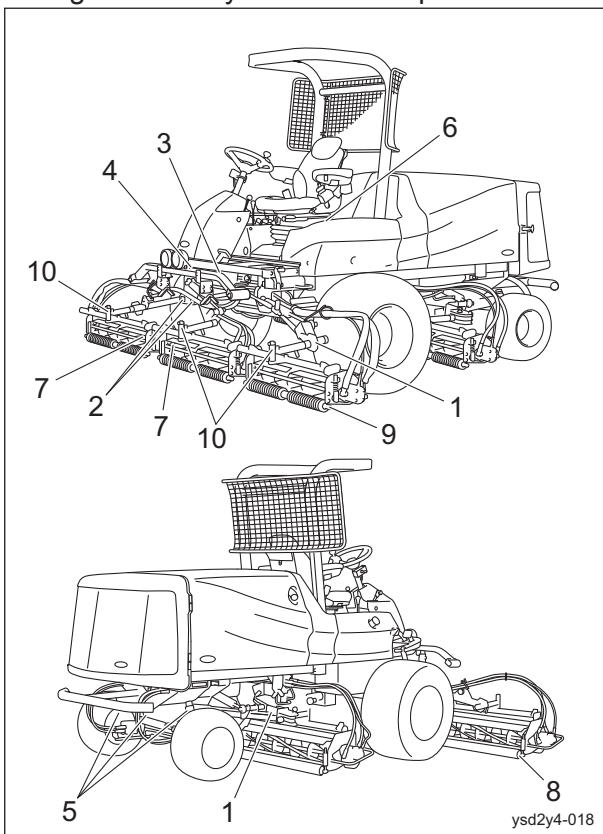

Type_F_001

	Location	No. of greasing points
1	Mower arm fulcrum	5
2	Lift arm fulcrum	5
3	Brake lever shaft	2
4	Traveling pedal shaft fulcrum	2
5	Pivot	3
6	Neutral position area	2
7	Reel housing	5
8	Rear roller	10
9	Front roller	10
10	Mower unit fulcrum	5

1. Mower arm fulcrum

There is one greasing point on each mower arm fulcrum connected to a mower unit.

Grease mower units #2 and #3 in the swiveled position.

"Swiveling Mower Units #2 and #3" (Page 5-33)

Mower units #1, #4 and #5

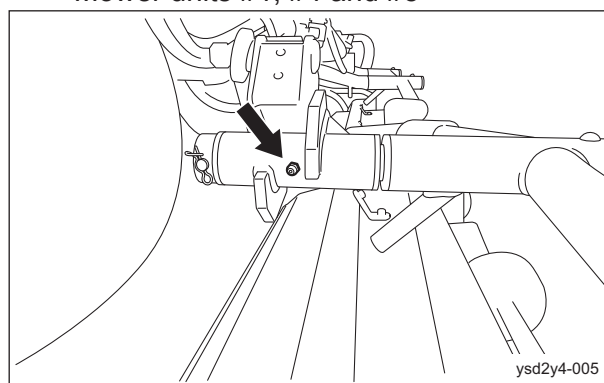

ysd2y4-005

Type_F_002

Mower units #2 and #3

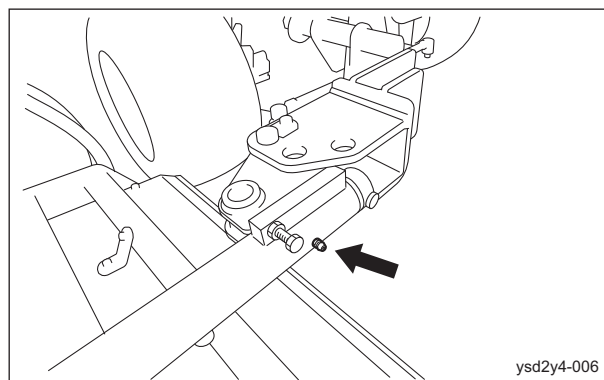

ysd2y4-006

Type_F_003

2. Lift arm fulcrum

There is one greasing point on each lift arm fulcrum connected to a mower unit.

Lower the mower units before greasing the lift arm fulcrums.

Mower units #1 and #4

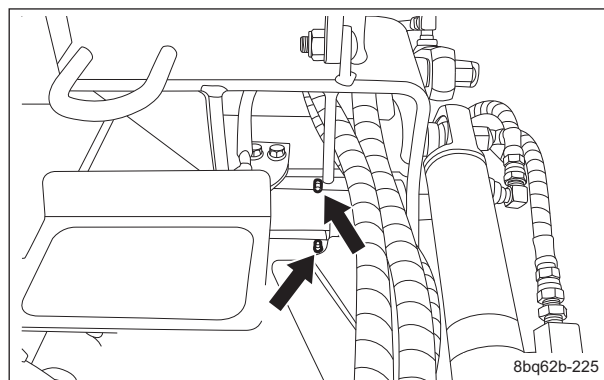

8bq62b-225

Type_F_004

Maintenance

Mower units #2 and #3

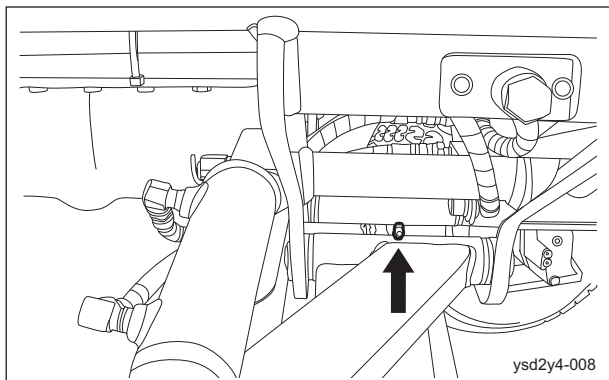

Type_F_005

Mower unit #5

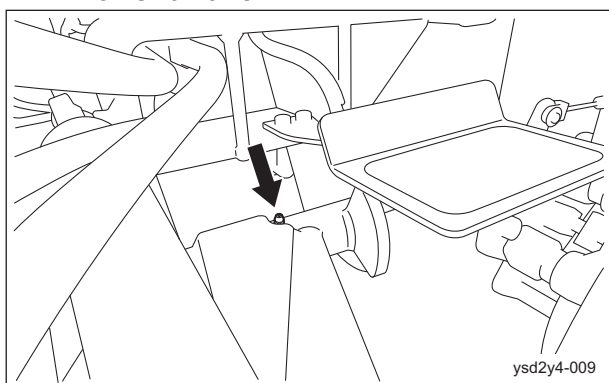

Type_F_006

3. Brake lever shaft

There are two greasing points on the brake lever shaft.

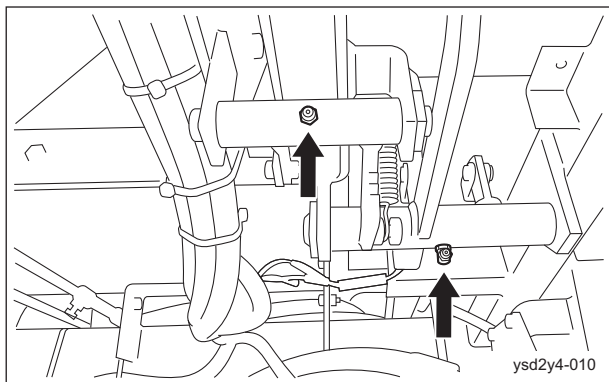

Type_F_007

4. Traveling pedal shaft fulcrum

There are two greasing points on the traveling pedal shaft fulcrum.

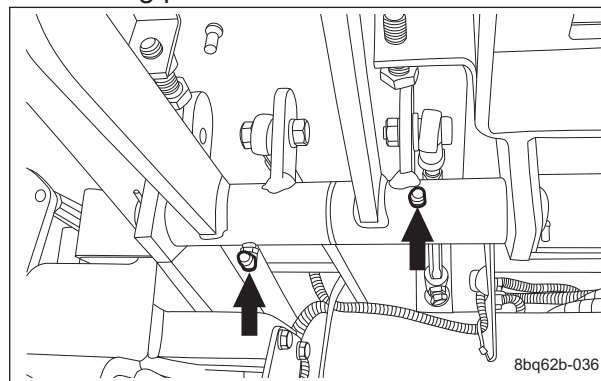

Type_F_008

5. Pivot

Middle between the rear wheels

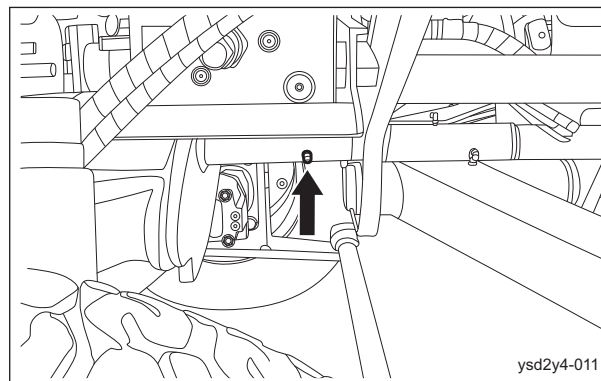

Type_F_009

Rear left wheel

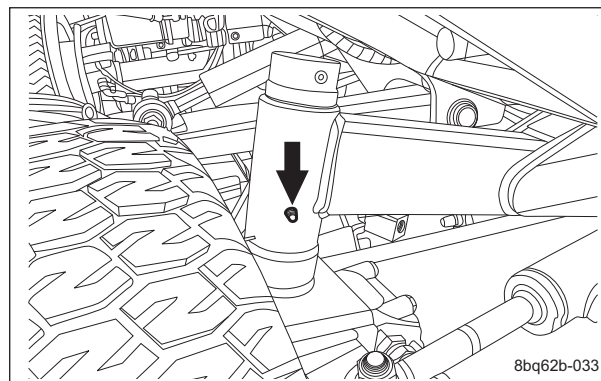

Type_F_010

Rear right wheel

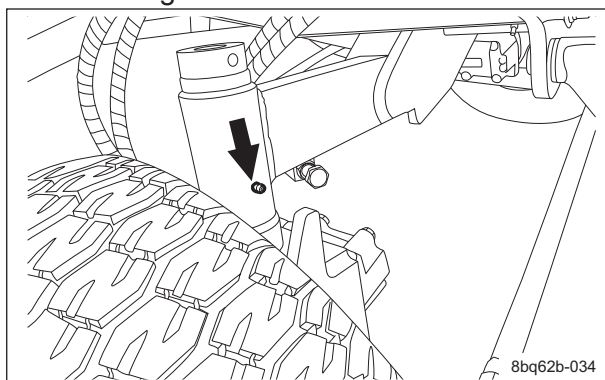

8bq62b-034

Type_F_011

6. Neutral position area

There are two greasing points on the neutral position area.

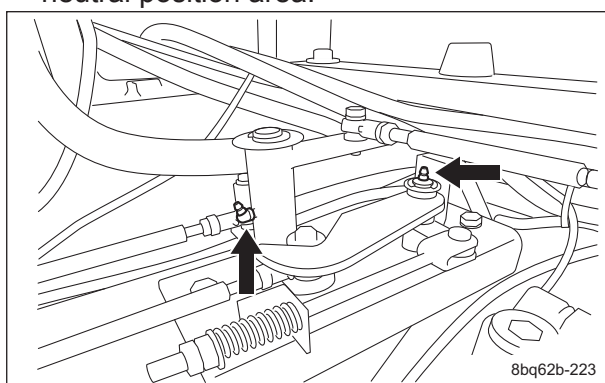

8bq62b-223

Type_F_012

7. Reel housing

There is one greasing point on each mower unit reel housing.

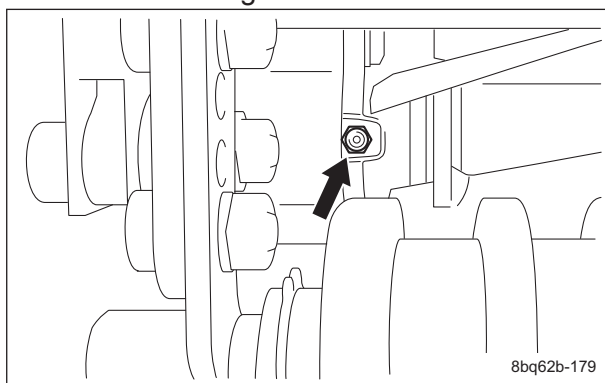

8bq62b-179

Type_F_013

8. Rear roller

There is one greasing point on the left and right of the rear roller of each mower unit.

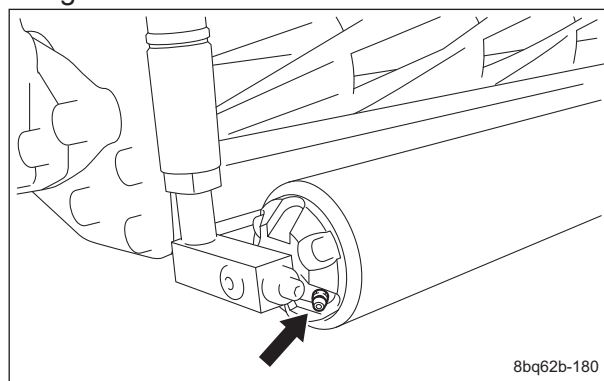

8bq62b-180

Type_F_014

9. Front roller

There is one greasing point on the left and right of the front roller of each mower unit.

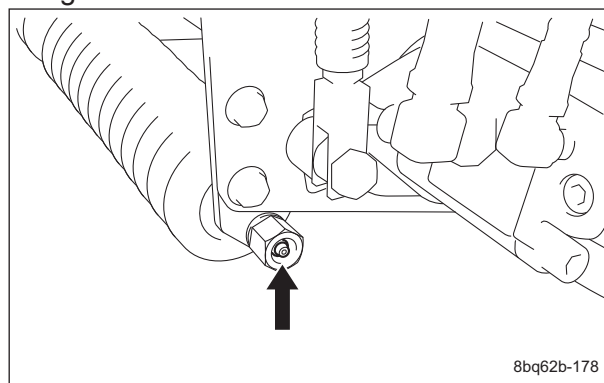

8bq62b-178

Type_F_015

10. Mower unit fulcrum

There is one greasing point on each mower unit fulcrum.

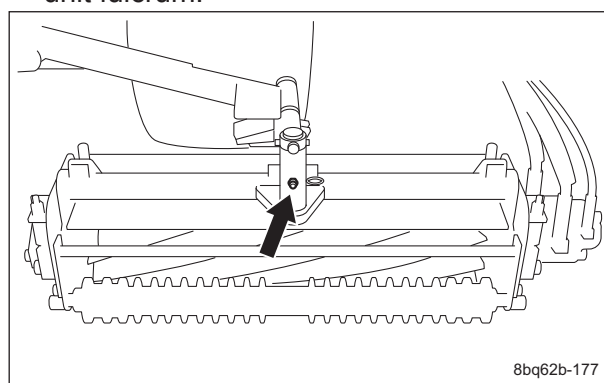

8bq62b-177

Type_F_016

Maintenance

Type_R

Grease nipples are installed in the following locations.

Add grease every 50 hours of operation.

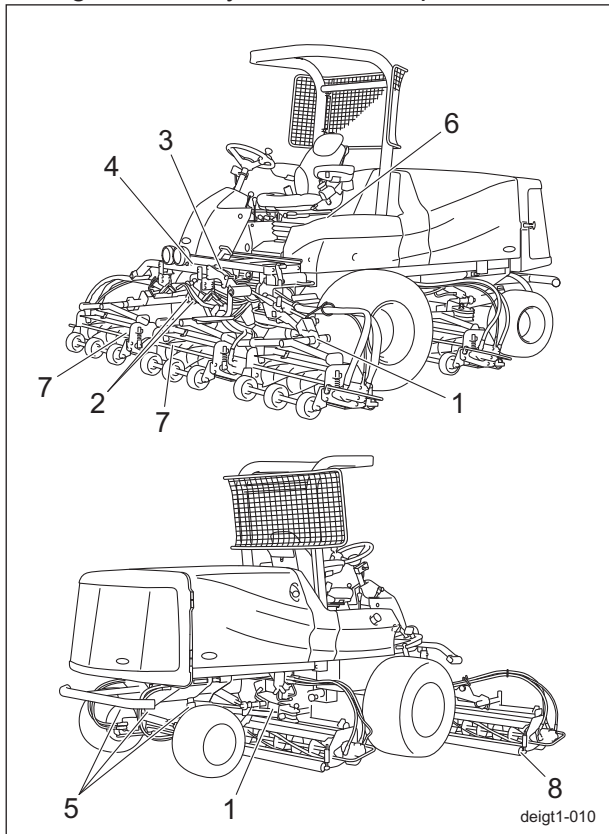

Type_R_001

	Location	No. of greasing points
1	Mower arm fulcrum	5
2	Lift arm fulcrum	5
3	Brake lever shaft	2
4	Traveling pedal shaft fulcrum	2
5	Pivot	3
6	Neutral position area	2
7	Reel housing	5
8	Rear roller	10

1. Mower arm fulcrum

There is one greasing point on each mower arm fulcrum connected to a mower unit.

Grease mower units #2 and #3 in the swiveled position.

"Swiveling Mower Units #2 and #3" (Page 5-33)

Mower units #1, #4 and #5

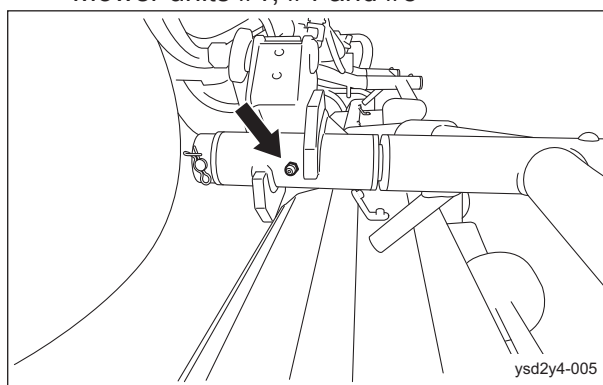

Type_R_002

Mower units #2 and #3

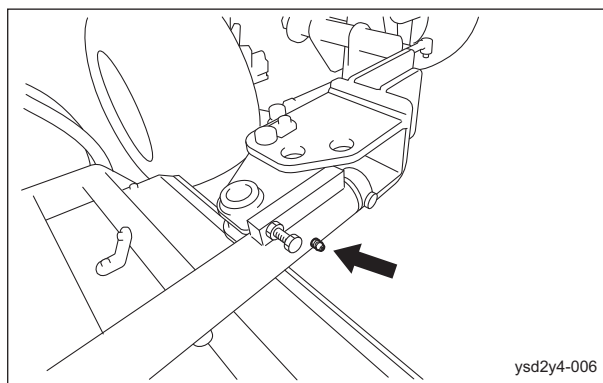

Type_R_003

2. Lift arm fulcrum

There is one greasing point on each lift arm fulcrum connected to a mower unit.

Lower the mower units before greasing the lift arm fulcrums.

Mower units #1 and #4

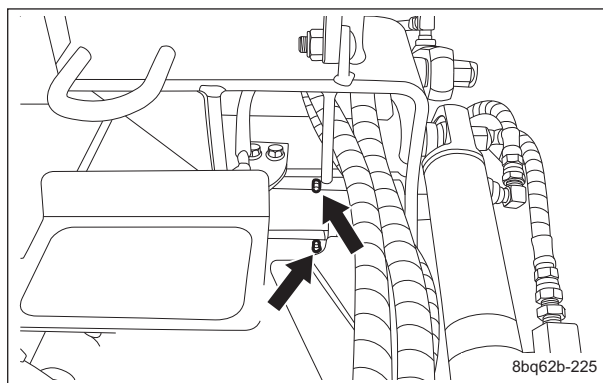

Type_R_004

Mower units #2 and #3

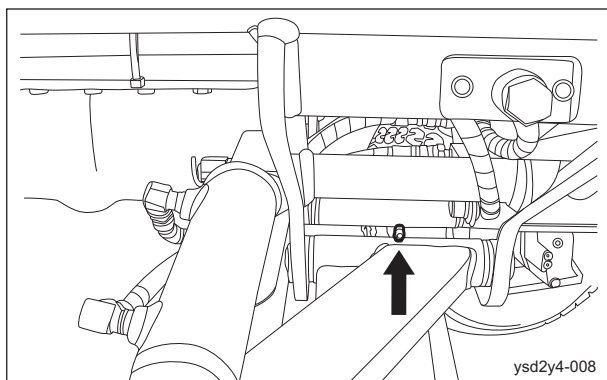

Type_R_005

Mower unit #5

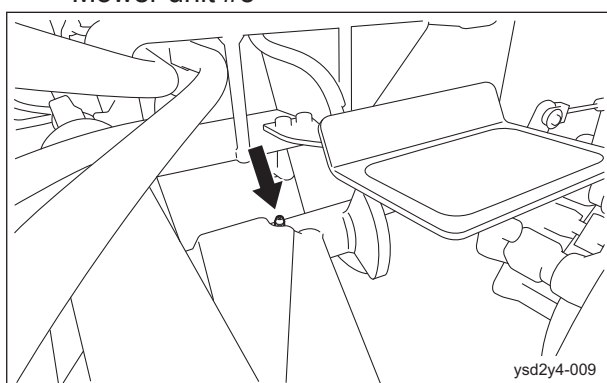

Type_R_006

3. Brake lever shaft
There are two greasing points on the brake lever shaft.

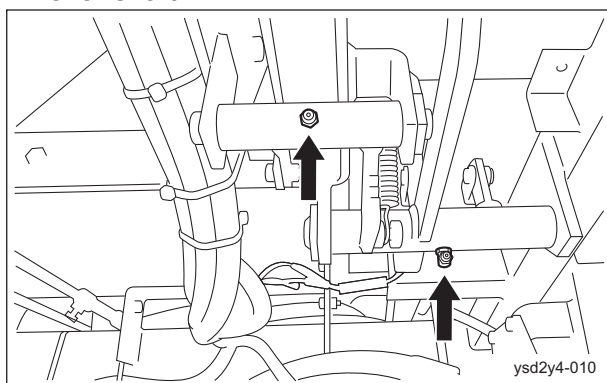

Type_R_007

4. Traveling pedal shaft fulcrum
There are two greasing points on the traveling pedal shaft fulcrum.

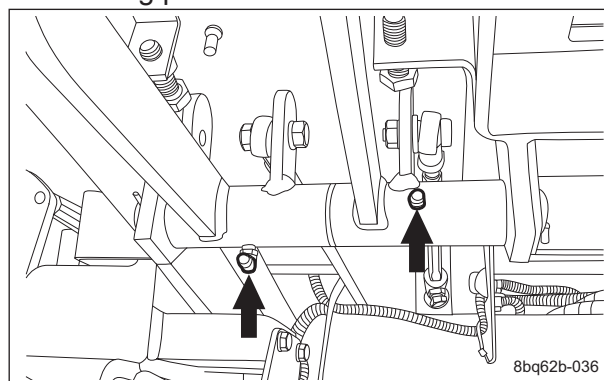

Type_R_008

5. Pivot
Middle between the rear wheels

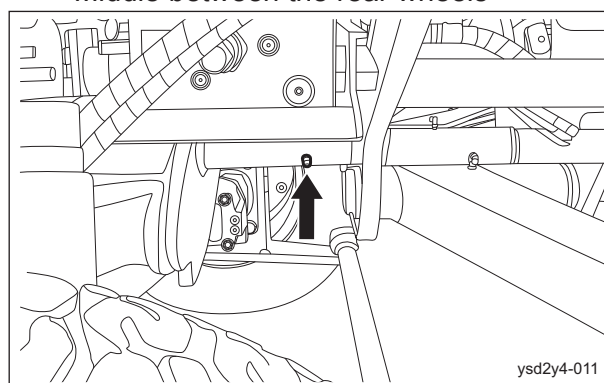

Type_R_009

Rear left wheel

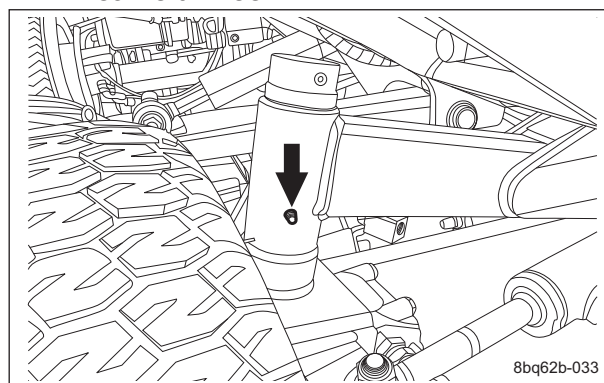

Type_R_010

Maintenance

Rear right wheel

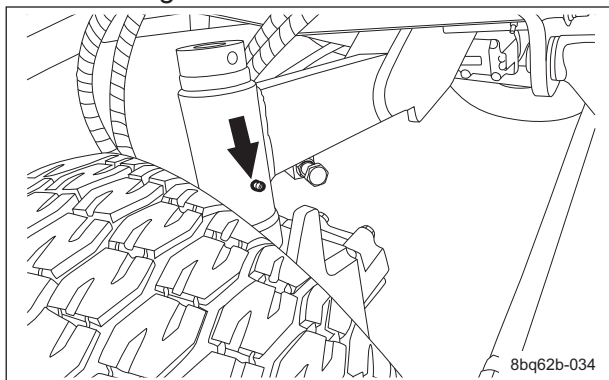

Type_R_011

6. Neutral position area

There are two greasing points on the neutral position area.

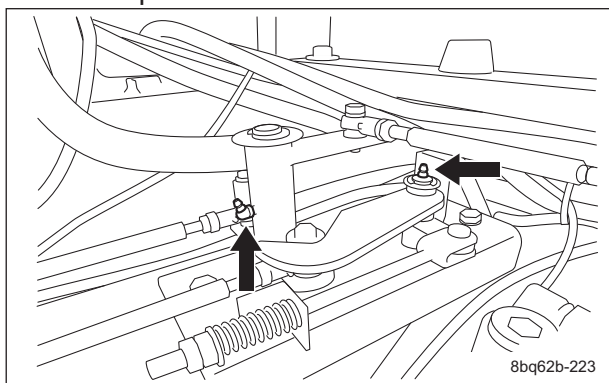

Type_R_012

7. Reel housing

There is one greasing point on each mower unit reel housing.

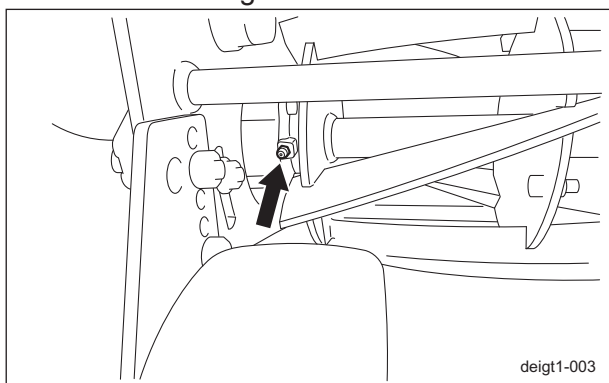

Type_R_013

8. Rear roller

There is one greasing point on the left and right of the rear roller of each mower unit.

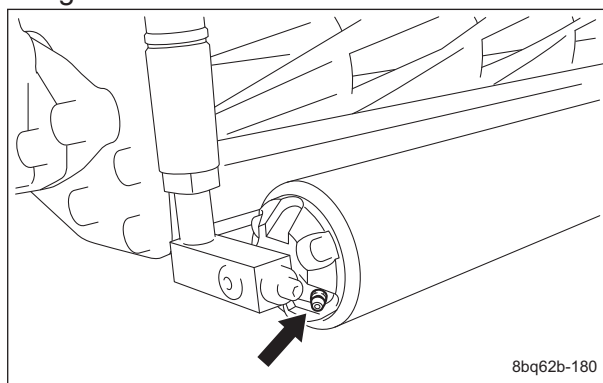

Type_R_014

Lubrication

About Lubrication

It is necessary to lubricate moving parts so that they will not become stuck or damaged. The locations where lubricant is used are indicated in "Lubricating Points". Apply the lubricant.

Lubricating Points

Type_F

Apply lubricant at the following locations every 50 hours of operation.

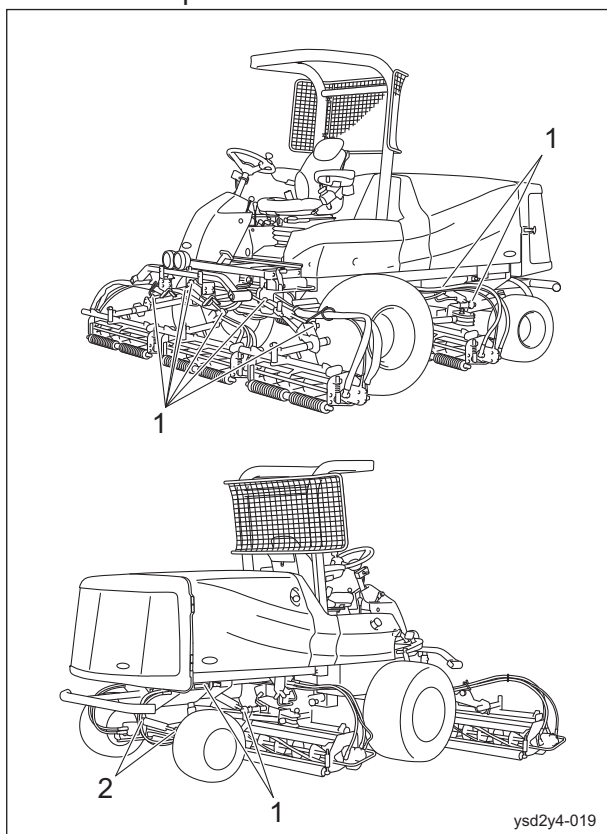

Type_F_001

	Location	No. of lubricating points
1	Mower cylinder spherical bearing	10
2	Steering cylinder spherical bearing	2

- Mower cylinder spherical bearing
There are two points on each mower cylinder.

Mower cylinder #1

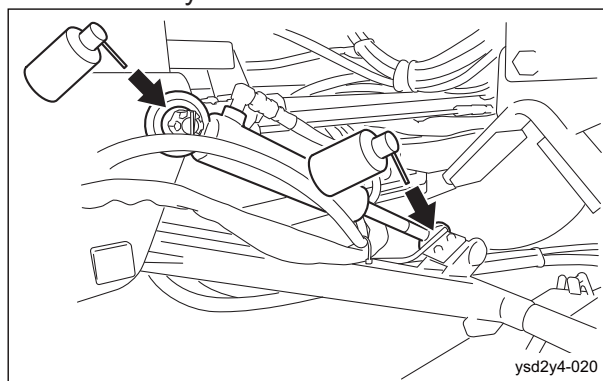

Type_F_002

Mower cylinder #2 and 3

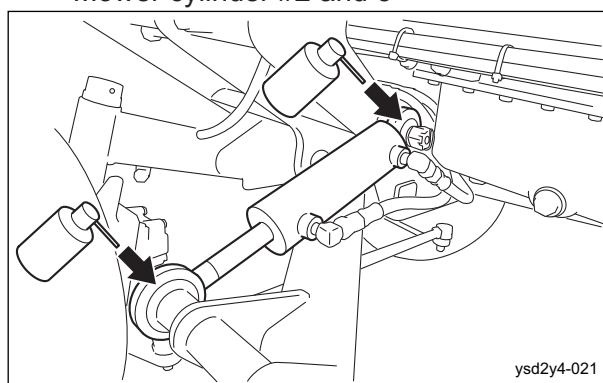

Type_F_003

Mower cylinder #4 and 5

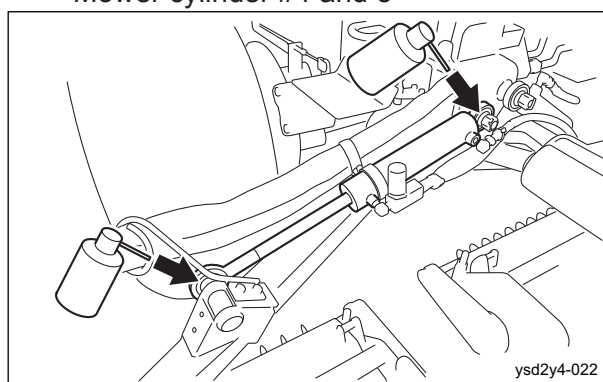

Type_F_004

Maintenance

2. Steering cylinder spherical bearing There are two points.

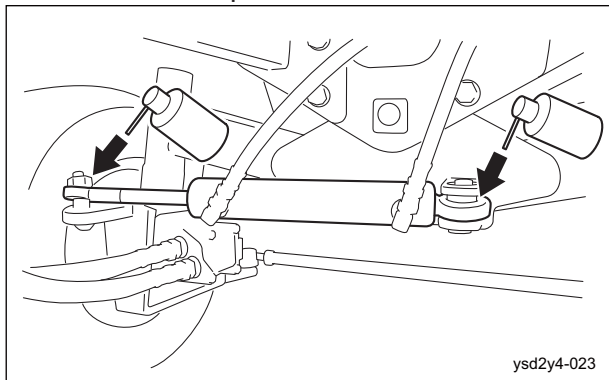

Type_F_005

1. Mower cylinder spherical bearing There are two points on each mower cylinder.

Mower cylinder #1

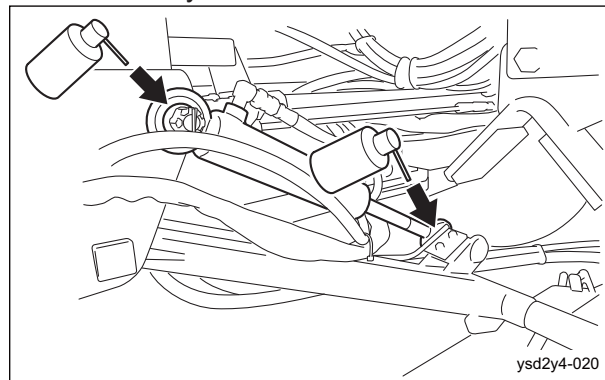

Type_R_002

Mower cylinder #2 and 3

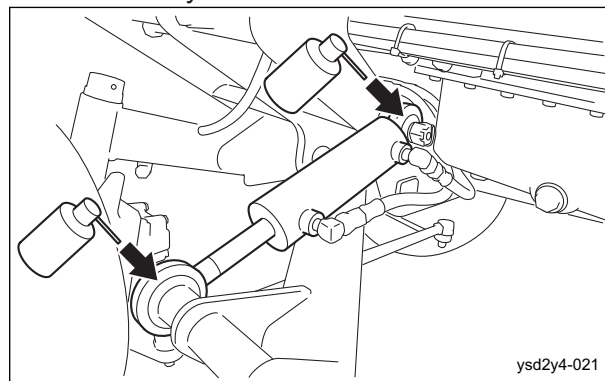

Type_R_003

Mower cylinder #4 and 5

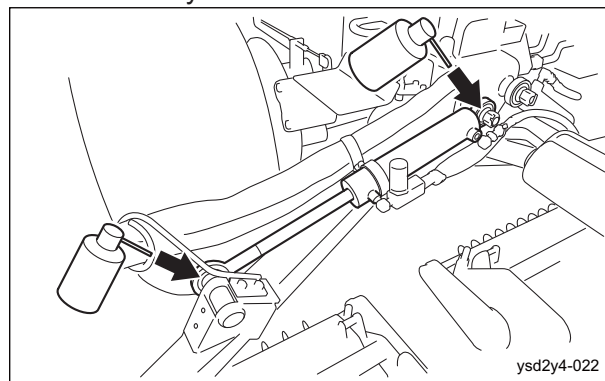

Type_R_004

Type_R

Apply lubricant at the following locations every 50 hours of operation.

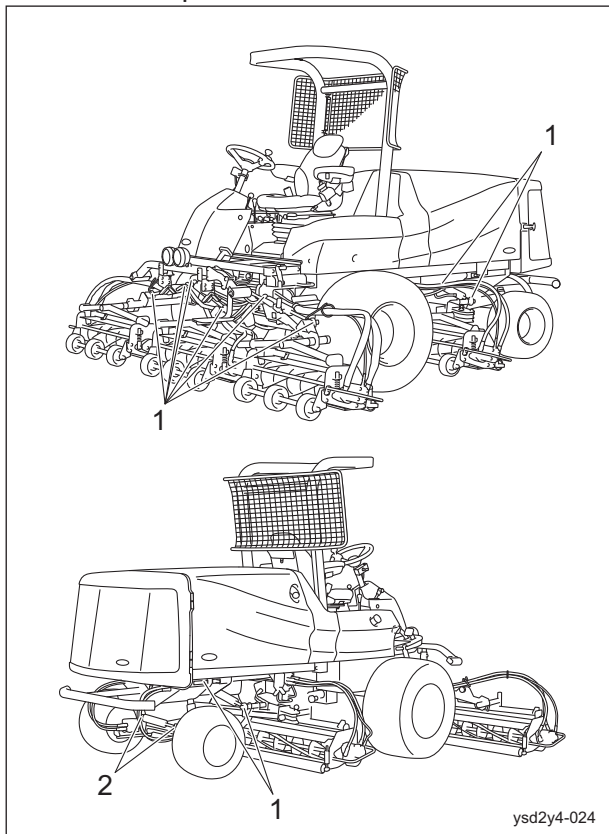

Type_R_001

	Location	No. of lubricating points
1	Mower cylinder spherical bearing	10
2	Steering cylinder spherical bearing	2

2. Steering cylinder spherical bearing

There are two points.

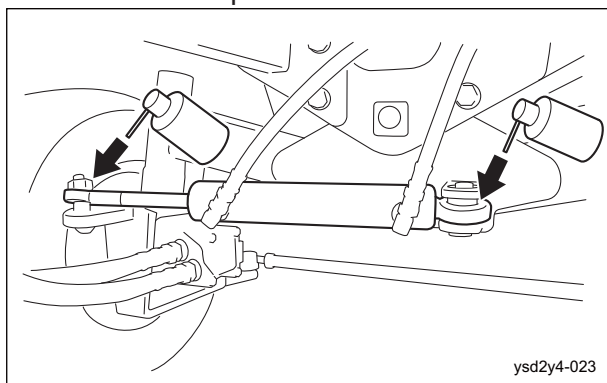

ysd2y4-023

Type_R_005

Maintenance Work

Cleaning of Mower Unit

Important

While cleaning, do not allow water on the sealed parts of the reel shaft. (Avoid high-pressure water cleaning.) Otherwise, it may cause damage to the machine.

Be sure to clean the mower unit after use.

1. Stop the engine, and then remove the key.
2. Carefully clean the front and back of the mower unit with water or compressed air.
3. Remove any grass wrapped around the reel cutter (cutting cylinder).

Back Lapping

Back lapping is work similar to sharpening a cooking knife. If the edges of the reel cutter (cutting cylinder) and the bed knife (bottom blade) become blunt and make cutting difficult, both the reel cutter (cutting cylinder) and the bed knife (bottom blade) should be simultaneously sharpened by reversing the reel cutter (cutting cylinder) with an abrasive paste applied.

However, back lapping is a temporary measure and would not restore the sharpness completely.

If the edges of the reel cutter (cutting cylinder) and the bed knife (bottom blade) become blunt and make cutting difficult, follow the steps below to perform back lapping.

Warning

During back lapping, the reel cutter (cutting cylinder) rotates. Keep hands and feet away from moving parts.

Caution

Both the reel cutter (cutting cylinder) and the bed knife (bottom blade) are edged tools. Handle them carefully, since they could cut your hands and feet.

Caution

Be careful not to inhale exhaust gas during back lapping.

Caution

Do not perform back lapping with any other persons.

1. Have the following items ready: Strips of newspaper, Abrasive [Back lapping powder mixed with oil; or gel compound (Baroness genuine abrasive)], Brush.

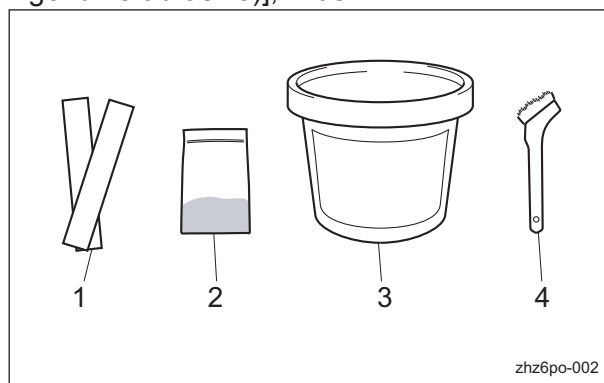

zhz6po-002

Back Lapping_001

1	Newspaper
2	Back lapping powder
3	Gel compound
4	Brush

Note:

The mixing ratio for the abrasive, in volume, is one part back lapping powder (#150 - #200) to three or four parts oil.

Maintenance

⚠ Caution

When handling the reel cutter (cutting cylinder) and the bed knife (bottom blade), wear gloves to protect your hands. Pay attention not to let the reel cutter (cutting cylinder) catch your gloves. Otherwise, you may injure your hand or fingers.

Important

Check the sharpness of the blade by checking the blade engagement after cutting grass.

2. Stop the engine.
3. Set the reel rotation/stop switching lever to the "Stop" position.

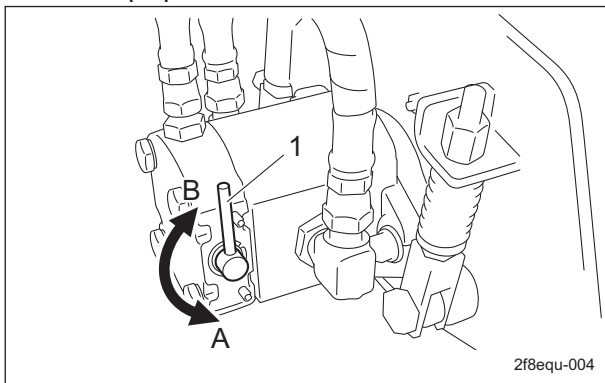

Back Lapping_002

1	Reel rotation/stop switching lever
A	Stop
B	Rotate

4. Insert two or three strips of newspaper into the space between the reel cutter (cutting cylinder) and the bed knife (bottom blade) at an angle of 90 degrees. Then, rotate the reel cutter (cutting cylinder) counter-clockwise (when you face the mower unit from the left) by hand to check the sharpness of the blades.
5. Check the sharpness of the entire range (three or four points) of the reel cutter (cutting cylinder).
6. Using a piece of chalk, mark locations on the blade that are sharp.
7. Shift the reel rotation/stop switching levers of the hydraulic motors in the mower units to be used for back lapping to the "Rotate" position.
Shift the levers for the mower units for which you will not perform back lapping to the "Stop" position.

8. Sit on the seat, apply the parking brake, and then start the engine.
Note:
If the reel rotation switch is set to the "Rotation" position, the engine will not start.
9. Lower all mower units to the ground.
10. Open the hood, and then set the reel reverse switch to the "Reverse" position.
11. Run the engine at a low rpm.
12. Set the reel rotation switch to the "Rotation" position to rotate the reel cutters (cutting cylinders) for back lapping.
13. With the reel rotation/stop switching lever, adjust the rotation speed of the reel cutter (cutting cylinder).
14. Apply the abrasive evenly with the brush on the top side of reel cutter (cutting cylinder) where the newspaper was cut well or of chalk-marked locations. (Never apply to blunt areas.)
15. Idle the engine for a while, and when contact noise is no longer heard, set the reel rotation switch to the "Stop" position to stop the reel cutters (cutting cylinders).
16. Raise all mower units.
17. Stop the engine.
18. Wash off or wipe off with a cloth, etc., the abrasive from the reel cutter (cutting cylinder), and then check it for sharpness.
19. Repeat steps 3 to 18 until the entire range (three or four points) of the reel cutter (cutting cylinder) is uniformly sharpened.
20. Finally, apply abrasive to the entire blade width of the reel cutter (cutting cylinder) and perform final back lapping.
21. Set the reel rotation switch to the "Stop" position to stop the rotation of the reel cutters (cutting cylinders), stop the engine, and then carefully and thoroughly wash off any remaining abrasive.
22. Set the reel reverse switch to the "Normal rotation" position.
23. Shift the reel rotation/stop switching lever to the "Stop" position.
24. While checking the blade for sharpness, adjust blade engagement.

Sharpening of Reel Cutter (Cutting Cylinder)

⚠ Caution

Both the reel cutter (cutting cylinder) and the bed knife (bottom blade) are edged tools. Handle them carefully, since they could cut your hands and feet.

⚠ Caution

Wear gloves when touching edged tools to avoid cutting your hands.

The sharpening of the reel cutter (cutting cylinder) consists in maintaining its roundness and creating a relief (second edge face). This work should be performed if the sharpness cannot be restored, even after back lapping, or if the relief (second edge face) has worn away.

Sharpen the reel cutter (cutting cylinder) when the sharpness cannot be restored, even after back lapping, or when the relief (second edge face) has worn away, there is full contact or back lapping takes too much time.

In addition, if the reel cutter (cutting cylinder) becomes worn and its shape conical, perform cylindrical grinding to return it to a cylindrical shape.

For sharpening the reel cutter (cutting cylinder), contact your dealer or Baroness. If the outer diameter of the reel cutter (cutting cylinder) after sharpening is more than the usage limit, the reel cutter (cutting cylinder) can be sharpened.

New		Usage limit	
Dimension A (Outer diameter of reel cutter (cutting cylinder))	Dimension B (Distance from blade edge to outer edge of reel cutter (cutting cylinder) shaft)	Dimension A (Outer diameter of reel cutter (cutting cylinder))	Dimension B (Distance from blade edge to outer edge of reel cutter (cutting cylinder) shaft)
205 mm (8.07 in)	87.5 mm (3.44 in)	185 mm (7.28 in)	77.5 mm (3.05 in)

Note:

The outer diameter of the reel cutter (cutting cylinder) shaft is 30 mm (1.18 in).

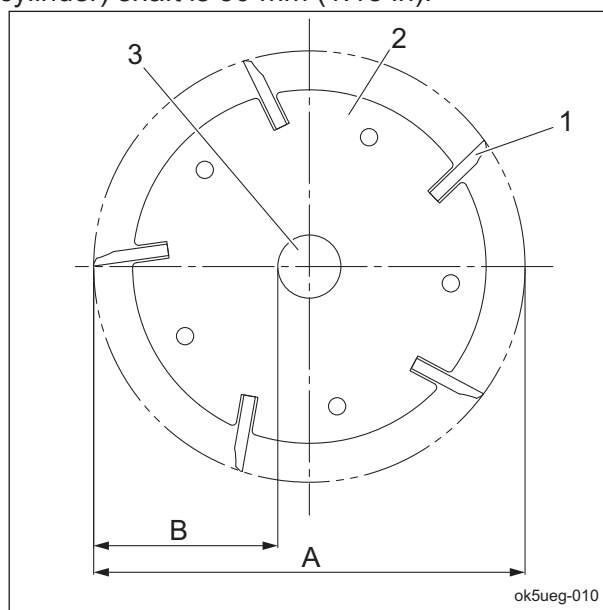

Sharpening of Reel Cutter (Cutting Cylinder)_001

1	Reel cutter (cutting cylinder) blade
2	Reel cutter (cutting cylinder) disc
3	Reel cutter (cutting cylinder) shaft
A	Outer diameter of reel cutter (cutting cylinder)
B	Distance from blade edge to outer edge of reel cutter (cutting cylinder) shaft

Sharpening is necessary when the reel cutter (cutting cylinder) reaches a condition described below.

1. When the sharpening width (length of contacting surface of bed knife (bottom blade)) for the outer diameter of the reel cutter (cutting cylinder) is greater than the usage limit.

Outer diameter of reel cutter (cutting cylinder) (new part)	Usage limit of sharpening width for outer diameter of reel cutter (cutting cylinder)
205 mm (8.07 in)	3.0 mm (0.12 in) (factory-recommended)

Maintenance

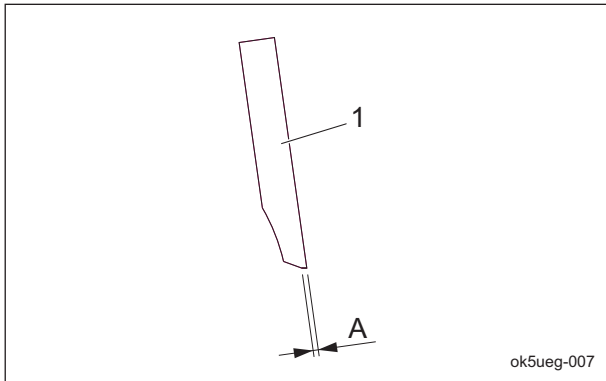

Sharpening of Reel Cutter (Cutting Cylinder)_002

1	Reel cutter (cutting cylinder) blade
A	Sharpening width for outer diameter of reel cutter (cutting cylinder)

2. When the edges become blunt or the blade edge cannot be formed with back lapping
3. When the reel cutter (cutting cylinder) becomes worn and its shape conical, or when blade engagement adjustment cannot be performed

Replacement of Reel Cutter (Cutting Cylinder)

Caution

Both the reel cutter (cutting cylinder) and the bed knife (bottom blade) are edged tools. Handle them carefully, since they could cut your hands and feet.

Caution

Wear gloves when touching edged tools to avoid cutting your hands.

The criteria for replacing the reel cutter (cutting cylinder) are described below.

However, these criteria are only a reference and do not guarantee performance like that of a new reel cutter (cutting cylinder).

1. When the outer diameter of the reel cutter (cutting cylinder) is less than the usage limit

New		Usage limit	
Dimension A (Outer diameter of reel cutter (cutting cylinder))	Dimension B (Distance from blade edge to outer edge of reel cutter (cutting cylinder) shaft)	Dimension A (Outer diameter of reel cutter (cutting cylinder))	Dimension B (Distance from blade edge to outer edge of reel cutter (cutting cylinder) shaft)
205 mm (8.07 in)	87.5 mm (3.44 in)	185 mm (7.28 in)	77.5 mm (3.05 in)

Note:

The outer diameter of the reel cutter (cutting cylinder) shaft is 30 mm (1.18 in).

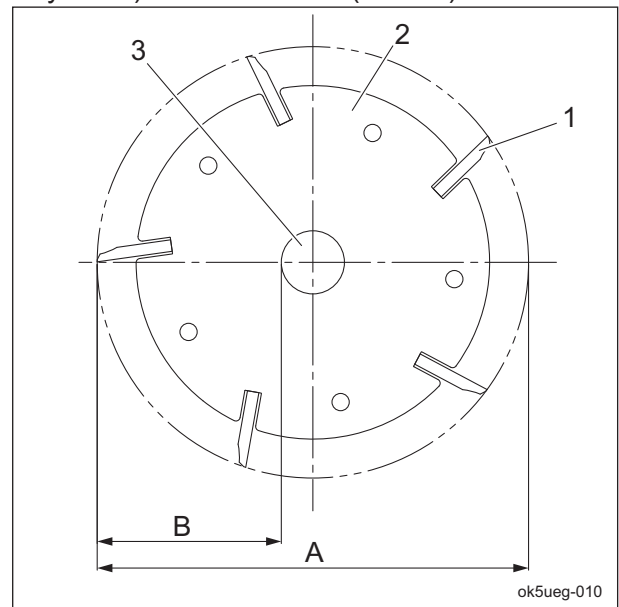

Replacement of Reel Cutter (Cutting Cylinder)_001

1	Reel cutter (cutting cylinder) blade
2	Reel cutter (cutting cylinder) disc
3	Reel cutter (cutting cylinder) shaft
A	Outer diameter of reel cutter (cutting cylinder)
B	Distance from blade edge to outer edge of reel cutter (cutting cylinder) shaft

Replacement of Bed Knife (Bottom Blade)

⚠ Caution

Both the reel cutter (cutting cylinder) and the bed knife (bottom blade) are edged tools. Handle them carefully, since they could cut your hands and feet.

⚠ Caution

Wear gloves when touching edged tools to avoid cutting your hands.

The criteria for replacing the bed knife (bottom blade) are described below.

1. When the reel cutter (cutting cylinder) is ground
 2. When the reel cutter (cutting cylinder) is replaced
 3. When the bed knife (bottom blade) is worn High-speed-steel-tipped blade
- Replace the bed knife (bottom blade) before it no longer has a tip.

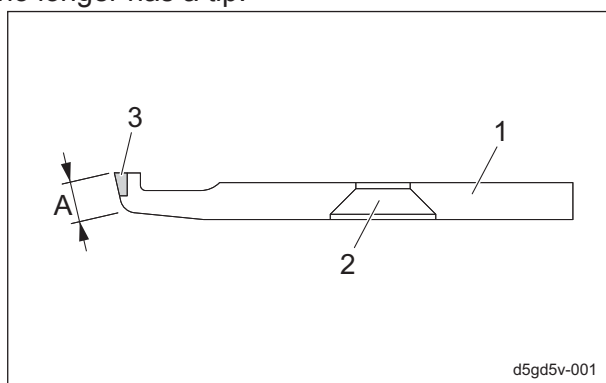

Replacement of Bed Knife (Bottom Blade)_001

1	Bed knife (bottom blade)
2	Mounting hole
3	Tip
A	Front face

Swiveling Mower Units #2 and #3

⚠ Caution

Both the reel cutter (cutting cylinder) and the bed knife (bottom blade) are edged tools. Handle them carefully, since they could cut your hands and feet.

⚠ Caution

Be careful not to inhale exhaust gas while swiveling the mower units.

Maintenance can be performed more easily with mower units #2 and #3 swiveled.

1. Lower the mower units, and then stop the engine.
2. Remove the clip pin, and then remove the grip pin.

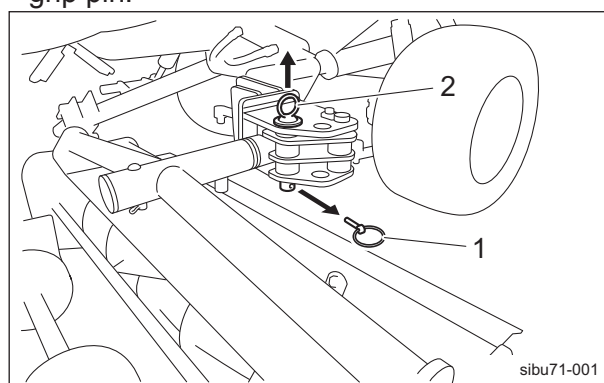

Swiveling Mower Units #2 and #3_001

1	Clip pin
2	Grip pin

3. Swivel the mower unit toward the outside of the machine.

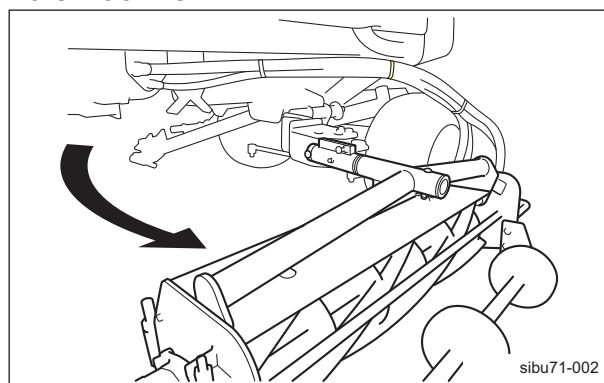

Swiveling Mower Units #2 and #3_002

Maintenance

4. Fully insert the grip pin into the locking hole for maintenance, and then install the clip pin in the grip pin.

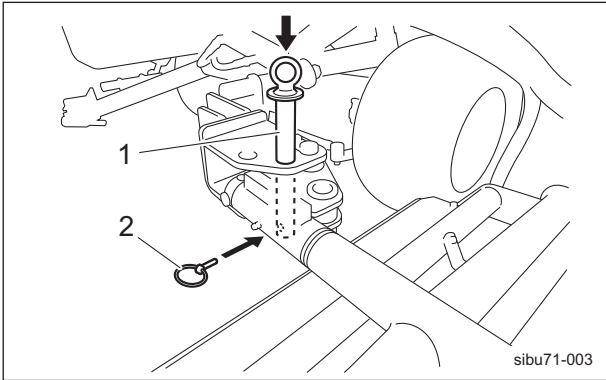

Swiveling Mower Units #2 and #3_003

1	Grip pin
2	Clip pin

5. Start the engine, and then raise the mower units.

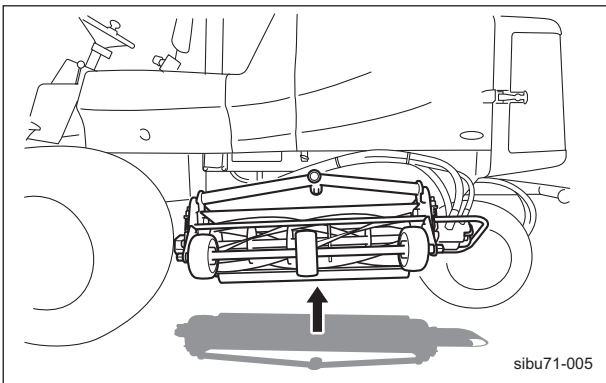

Swiveling Mower Units #2 and #3_004

6. After the maintenance is completed, reverse the procedure to return the machine to its original condition.

Removing/Installing Tires

Front Tires

Follow the steps below to remove the front tires:

1. Loosen the bolts.

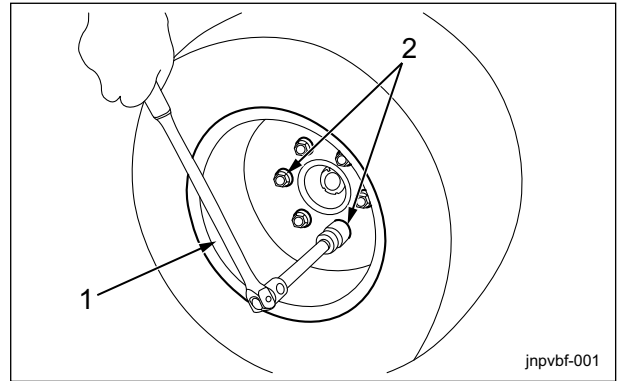

Front Tires_001

1	Front tire
2	Heat-treated bolt

2. Securely place the jack beneath the jack-up point of the front left/right frame area, and then raise it until the tire lifts off the ground. "Jack-Up Points" (Page 5-19)
3. Remove the bolts.
4. Remove the tire from the wheel mounting seat.

Important

Tighten the bolts in the tightening order (crosswise).

For installing the front tires, reverse the removing procedure.

Rear Tire

Follow the steps below to remove the rear tire.

1. Loosen the bolts.

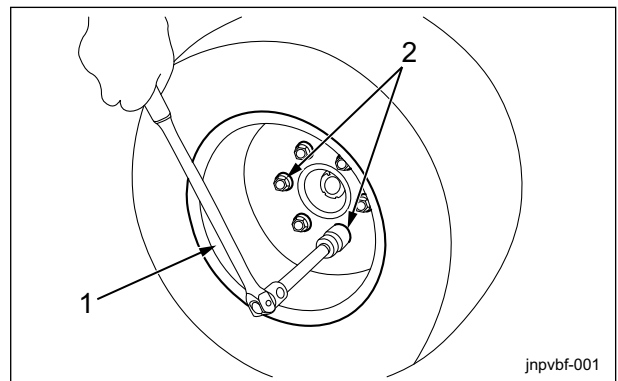

Rear Tire_001

1	Rear tire
2	Heat-treated bolt

- Securely place the jack beneath the jack-up point below the rear wheel motor, and then raise it until the tire lifts off the ground. "Jack-Up Points" (Page 5-19)
- Remove the bolts.
- Remove the tire from the wheel mounting base.

Important

Tighten the bolts in the tightening order (diagonally).

For installing the rear tire, reverse the removing procedure.

Adjustment of Belt Tension**Warning**

Be sure to stop the engine before adjusting the belts.

Important

Before making sure of belt tension, rotate the belt several times.

If the belt becomes slack due to frequent use, it may jump or slip.

In addition, if it is overtightened, it may wear prematurely.

If necessary, adjust it, and always check the belt for appropriate tension.

Fan Belt

- Press the middle of the belt with your finger to check the belt tension.
- If the belt tension is inappropriate, loosen bolts A and B (that affix the alternator), and then move the alternator to adjust the tension.

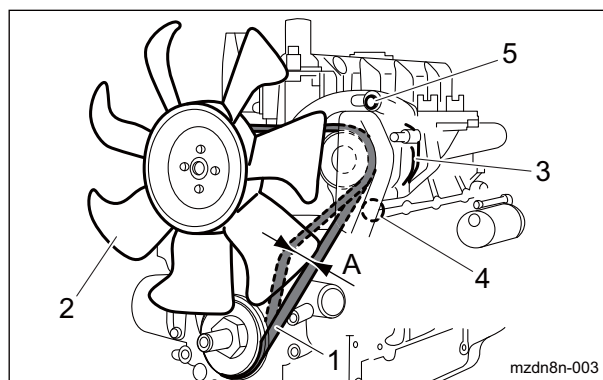

Fan Belt_001

1	Fan belt
2	Blade
3	Alternator
4	Bolt A
5	Bolt B
A	7.0 - 9.0 mm (0.28 - 0.35 in)

CR Brush Drive Belt**Note:**

Depending on the specifications, this function may not be available.

- Remove the belt cover.
- Check the belt tension.
- If the belt tension is inappropriate, adjust the belt tension with the tension pulley adjustment bolt.

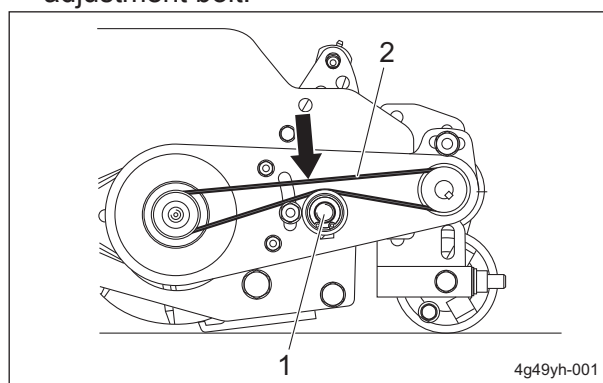

CR Brush Drive Belt_001

1	Tension pulley adjustment bolt
2	Belt

The belt tension is appropriate when the belt slacks by approximately 5.0 to 6.0 mm (0.197 to 0.236 in) when you apply a force of 10.0 N (1.0 kgf) with your finger to the belt at the middle point between the pulleys.

Maintenance

Adjustment of Brake

Caution

Make sure that the brake wire is not cracked or damaged.

Important

If the brake is not sufficiently effective due to a wider clearance gap between the brake disc and the brake lining, adjust the clearance. The wire is used for fine adjustments.

Important

Adjust the brake with the brake lining.

The brake lining wear limit is 3.0 mm (0.12 in).

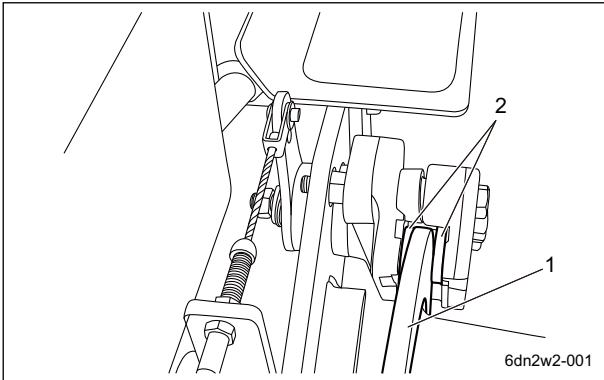

Adjustment of Brake_001

1	Brake disc
2	Brake lining

Caution

Make sure that the lever is maintained in the open position (neutral).

1. For each wheel, fully tighten the adjustment bolt on the brake disc side.

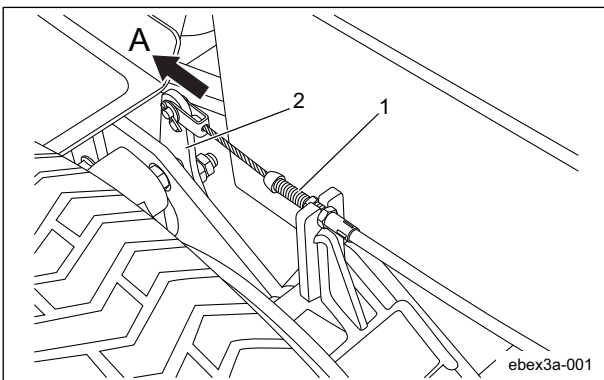

Adjustment of Brake_002

1	Adjustment bolt (on brake disc side)
2	Lever
A	Open (neutral)

2. Reduce the clearance by loosening the lock nut, then tightening the adjustment nut. Tighten the adjustment nut until the brake lining contacts the friction surface of the disc.

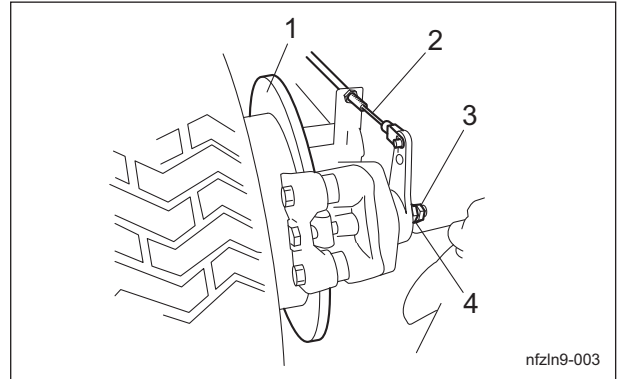

Adjustment of Brake_003

1	Brake disc
2	Wire
3	Lock nut
4	Adjustment nut

Warning

Too narrow clearance gap between the brake disc and brake lining may cause heat generation and fire.

- Loosen the adjustment nut to adjust the clearance gap between the brake disc and brake lining to about 0.2 mm (0.0079 in).
- Securely place the jack beneath the jack-up point of the front left/right frame area, and then raise it until both tires lift off the ground.
- Check that the disc rotates freely.
- Fully tighten the lock nut while holding the adjustment nut in place.

7. With the brake pedal released, obtain a play of 1.0 mm (0.039 in) at the joint part of the inner wire.

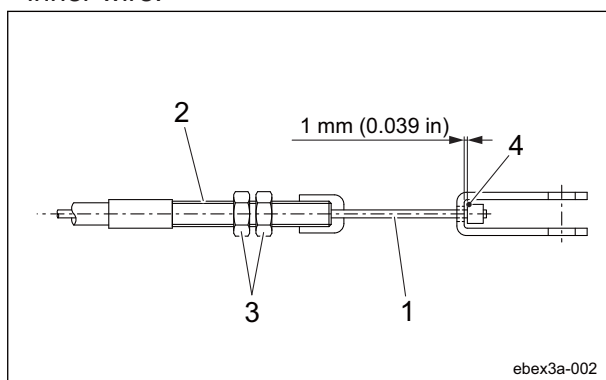

Adjustment of Brake_004

1	Inner wire
2	Adjustment bolt
3	Lock nut
4	Joint part

8. Use a wrench to loosen the lock nut and tighten it after making the adjustment with the adjustment bolt.
9. Drive, and then check the following.
- Make sure that heat is not generated in the brake area.
 - Make sure that the left and right brakes are equally effective.

Caution

It would be extremely dangerous and may result in an unexpected accident if the left and right brakes are not equally effective.

10. If the left and right brakes are not equally effective, make fine adjustments with the adjustment bolt on the brake disc side.

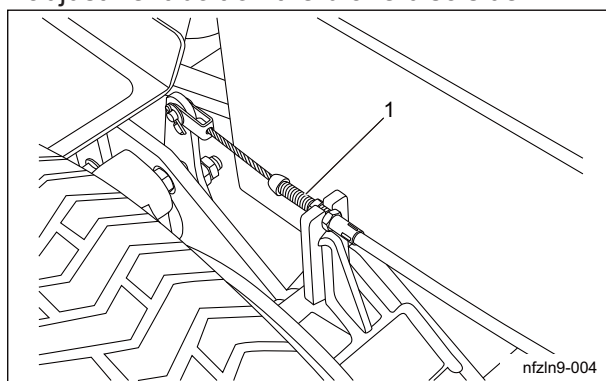

Adjustment of Brake_005

1	Adjustment bolt (on brake disc side)
---	--------------------------------------

Break-In of Brakes

If the brake shoes or brake pads are worn, replace them with new ones. Immediately after replacement, drive to break in the brakes if the effectiveness of the brakes is low. While driving, lightly operate the brakes to break in the contact areas.

Adjusting the Neutral Position of the Piston Pump

Caution

Make sure not to touch rotating tires.

Caution

When adjusting the neutral position, pay close attention to abrupt start of the machine. Place the jacks beneath the jack-up points, and then lift the machine until all the tires get off the ground.

If the machine moves forward or backward while the traveling pedals are released, they are not set to the neutral position. Follow the steps below to make adjustments.

1. Stop the engine.
2. Place the jacks beneath the jack-up points, and then lift the machine off the ground.
3. Make sure that no tires come into contact with the jack stand.
4. Make sure that the steering wheel is raised completely.
5. Pull up the forward/backward adjustment lever, and then slide the seat backward completely.

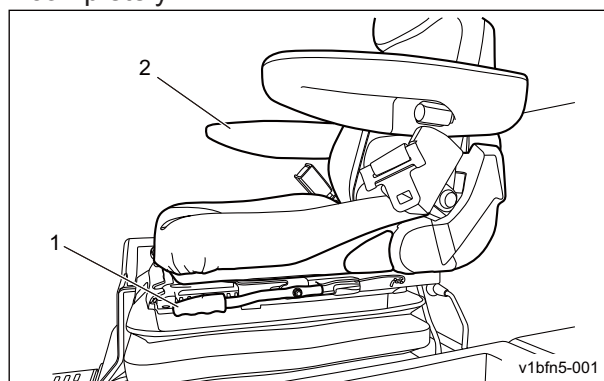

Adjusting the Neutral Position of the Piston Pump_001

1	Forward/backward adjustment lever
2	Seat

Maintenance

- While pulling up the lever, tilt the seat upward.

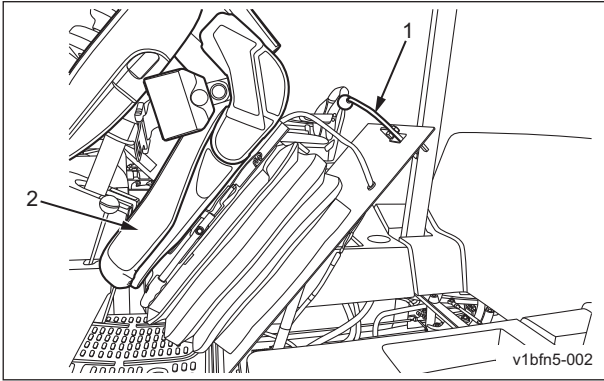

Adjusting the Neutral Position of the Piston Pump_002

1	Lever
2	Seat

- Start the engine, and rev it up to the maximum rpm.
- Set the 2WD/4WD selector switch to the "2WD" position.
- Adjust the neutral position.
 - [1] If the front tires rotate forward, loosen the lock nuts, and then turn the neutral adjustment rod to shorten it.
 - [2] If the front tires rotate in reverse, loosen the lock nuts, and then turn the neutral adjustment rod to extend it.

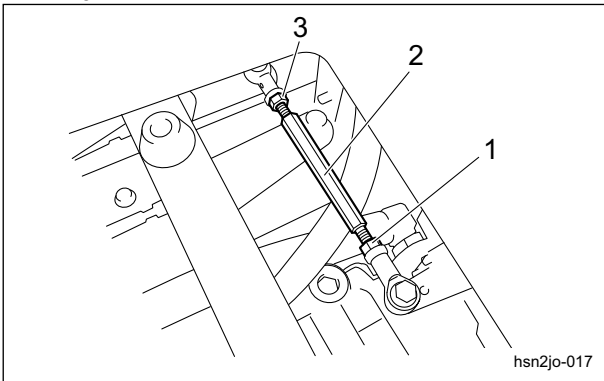

Adjusting the Neutral Position of the Piston Pump_003

1	Lock nut A (Left-hand thread)
2	Neutral adjustment rod
3	Lock nut B (Right-hand thread)

- Find the position where the front wheels stop, and then tighten the lock nuts.

Change of Coolant

⚠ Caution

Do not touch the radiator or coolant during engine operation or immediately after the engine has been turned off. Otherwise, you may get burned.

⚠ Caution

Change coolant after the engine has well cooled down.

⚠ Caution

The radiator cap is pressurized. If you remove the radiator cap while the engine is overheated, hot steam will burst out, possibly resulting in burns. Make sure that the water temperature and pressure are reduced, and then grab the cap with a thick cloth and gradually open the cap.

Important

When changing the coolant, be sure to drain it into a container and discard it in accordance with local laws and regulations.

Important

When changing the coolant, be sure to mix clean water and antifreeze (long-life coolant), and then pour it into the radiator and reserve tank.

Important

Tightly close the radiator cap. If the cap is loose or incorrectly installed, water may leak and the engine may overheat.

When mixing antifreeze and clean water, refer to "Relationship between concentration of long-life coolant (LLC) and freezing temperature" below for the mixing ratio.
Relationship between concentration of long-life coolant (LLC) and freezing temperature

Freezing temperature	LLC concentration (volume %)
Down to -10 °C (14 °F)	20 %
Down to -15 °C (5 °F)	30 %
Down to -20 °C (-4 °F)	35 %
Down to -25 °C (-13 °F)	40 %

1. Stop the engine, and then allow the radiator to cool.
2. Open the hood.
3. Follow the steps below to drain the coolant.

[1] Position a container to drain the coolant into.

[2] Remove the drain plug from the radiator.

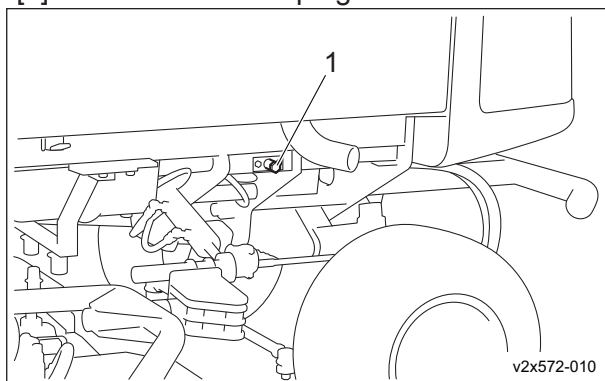

Change of Coolant_001

1	Radiator drain plug
---	---------------------

[3] Remove the radiator cap.

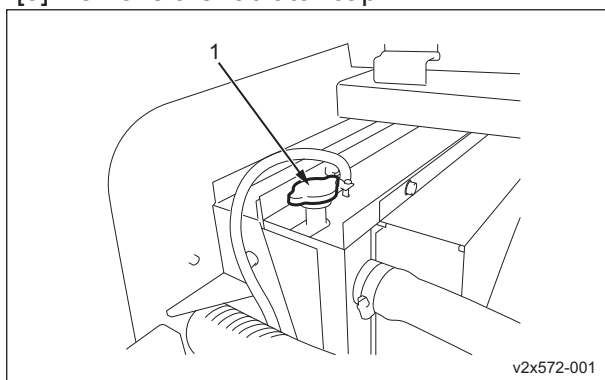

Change of Coolant_002

1	Radiator cap
---	--------------

[4] Remove the reserve tank.

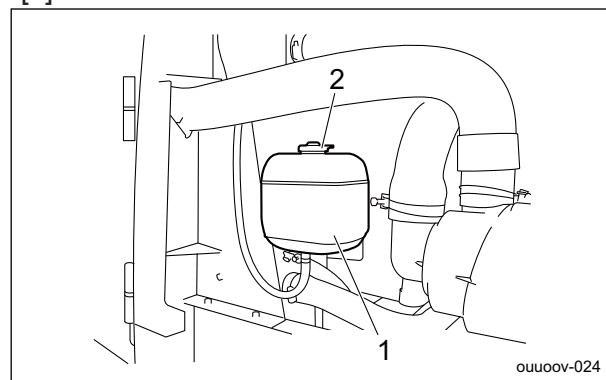

Change of Coolant_003

1	Reserve tank
2	Reserve tank cap

[5] Open the reserve tank cap, and then drain the coolant.

4. Install the reserve tank.
5. Clean the radiator with clean water to remove any debris or rust.
6. Drain all water from the radiator.
7. Follow the steps below to fill with coolant. The coolant quantity, including the reserve tank, is 12.0 dm³ (12.0 L).
- [1] Install the drain plug.
- [2] Supply clean water and antifreeze into the radiator up to the radiator cap opening.
- [3] Close the radiator cap.
- [4] Supply clean water and antifreeze into the reserve tank up to the "FULL" mark.
- [5] Close the reserve tank cap.
8. Start the engine, and then idle for several minutes to bleed air from the system.
9. Stop the engine, and then allow the radiator to cool.
10. Check if the coolant level in the reserve tank is between "FULL" and "LOW", and then supply coolant if necessary.
11. Close the hood.

Maintenance

Change of Hydraulic Oil

⚠ Caution

Be careful with hot oil, which could cause burns if it contacts your skin.

Important

When you change the hydraulic oil, be sure to drain it into a bowl and discard it in accordance with local laws and regulations.

Important

If the oil emulsifies or if it becomes even slightly less transparent, change the oil immediately.

Important

Use Shell Tellus S2M46 (or equivalent) as hydraulic oil.

1. Follow the steps below to remove the old oil.

- [1] Start and run the engine to warm up the oil.
- [2] On a level surface, lower the mower units, and then stop the engine.
- [3] Remove the drain plug of the hydraulic tank, and then drain the old oil into a container.
- [4] Wind new sealing tape on the drain plug, and then attach it to the hydraulic tank.

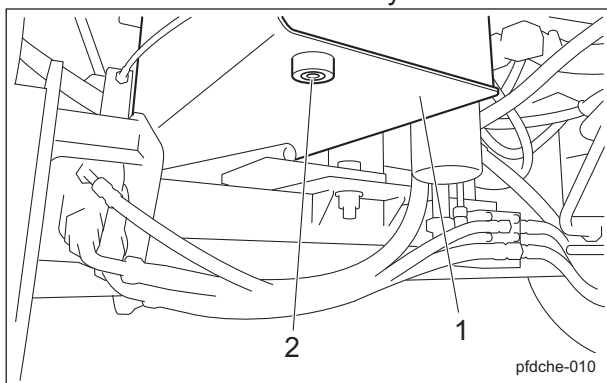

Change of Hydraulic Oil_001

1	Hydraulic tank
2	Drain plug

2. Remove the left tank cover.

3. Open the tank cap, and then pour new oil from the fill port until the oil level reaches the middle of the oil gauge on the hydraulic tank. The hydraulic tank capacity is approximately 44.0 dm³ (44.0 L).

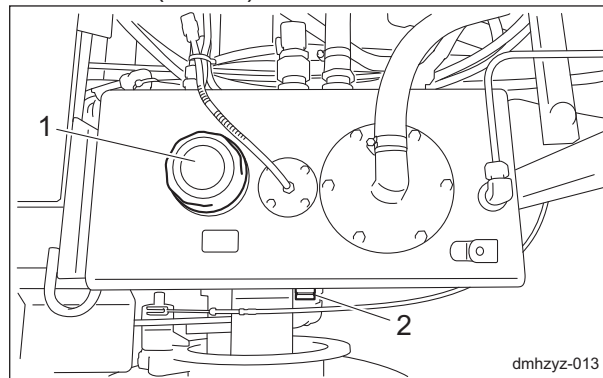

Change of Hydraulic Oil_002

1	Tank cap
2	Oil gauge

4. Tighten the tank cap securely.
5. Start the engine, raise and lower the mower units, and turn the steering wheel left and right. Move forward and reverse repeatedly several times.
6. Raise the mower units and maintain that position on a level surface, and then check to see if the oil level is at the middle of the oil gauge. If necessary, supply oil.
7. Check underneath the machine for oil leakage.
8. Attach the left tank cover.

Change of Hydraulic Oil Filter

Change of Hydraulic Oil Line Filter

⚠ Caution

Be careful with hot oil, which could cause burns if it contacts your skin.

Important

When replacing the hydraulic oil filter, be sure to drain the oil into a container and discard it in accordance with local laws and regulations.

Important

If the hydraulic oil emulsifies or if it becomes even slightly less transparent, change the oil immediately.

Important

Use Shell Tellus S2M46 (or equivalent) as hydraulic oil.

1. On a level surface, lower the mower units, and then stop the engine.
2. Remove the filter protecting plate.

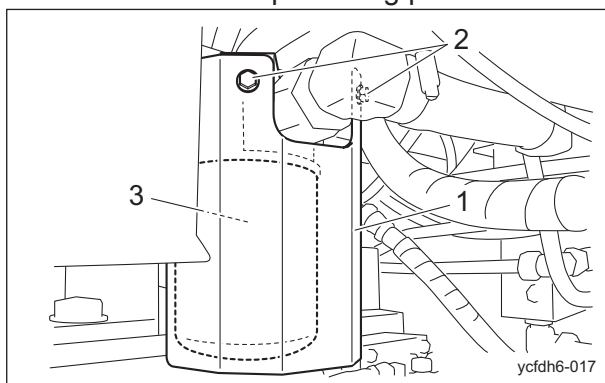

Change of Hydraulic Oil Line Filter_001

1	Filter protecting plate
2	Bolt
3	Filter cartridge

3. Loosen the old filter cartridge by hand and remove it.
4. Lightly coat the packing of the new filter cartridge with hydraulic oil, and then install the cartridge.

5. Firmly tighten the filter cartridge by hand until the packing contacts the mounting surface.
And then tighten it with a half more turn.

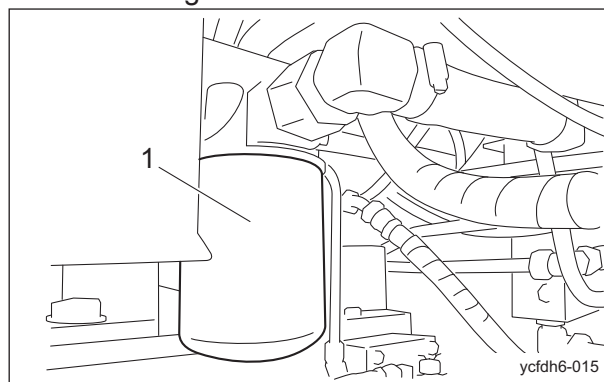

Change of Hydraulic Oil Line Filter_002

1	Cartridge filter
---	------------------

6. Supply hydraulic oil until it reaches the specified level.
"Hydraulic Oil Supply" (Page 4-7)
7. Install the filter protecting plate.
8. Start the engine and stop it after hydraulic oil warmed.
9. Check underneath the machine for hydraulic oil leakage.

Maintenance

Change of Hydraulic Oil Suction Filter

⚠ Caution

Be careful with hot oil, which could cause burns if it contacts your skin.

Important

When replacing the hydraulic oil filter, be sure to drain the oil into a container and discard it in accordance with local laws and regulations.

Important

If the hydraulic oil emulsifies or if it becomes even slightly less transparent, change the oil immediately.

Important

Use Shell Tellus S2M46 (or equivalent) as hydraulic oil.

Important

Replace the intake port packing with a new one.

1. On a level surface, lower the mower units, and then stop the engine.
2. Remove the left tank cover.
3. Remove bolts, spring washers and washers, and then remove the intake hose joint fitting.
4. Remove the old suction filter and intake port packing.
5. Remove all of the old liquid gasket from the hydraulic tank.
6. Remove all of the old liquid gasket and the intake port packing from the intake hose joint fitting.
7. Wash and clean the intake hose joint fitting.
8. Apply liquid gasket to the new intake port packing and then install it to the intake hose joint fitting.
9. Install the new suction filter to the intake hose joint fitting.

10. Install the intake hose joint fitting to the hydraulic tank.

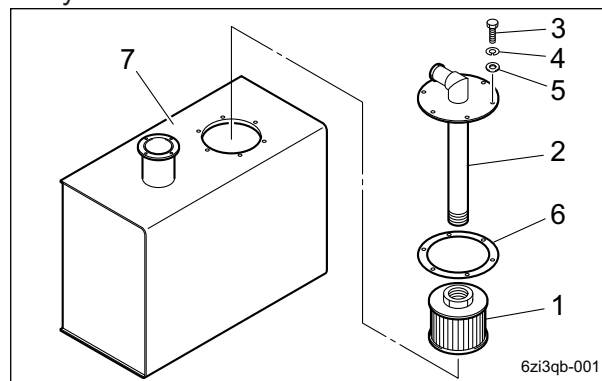

Change of Hydraulic Oil Suction Filter_001

1	Suction filter
2	Intake hose joint fitting
3	Bolt
4	Spring washer
5	Washer
6	Intake port packing
7	Hydraulic tank

11. Supply hydraulic oil until it reaches the specified level.
"Hydraulic Oil Supply" (Page 4-7)
12. Start the engine and stop it after hydraulic oil warmed.
13. Check underneath the machine for hydraulic oil leakage.
14. Install the left tank cover.

Change of Air Cleaner

A contaminated air cleaner element may cause malfunction of the engine.

To maximize the life of the engine, replace the air cleaner element at the appropriate times.

1. The timing for replacing the air cleaner element is described below.
 - [1] Replace the air cleaner element in accordance with the Maintenance Schedule.
 - [2] If it is significantly contaminated, replace it, even if the hours of operation do not exceed the specified time.
2. Replace the air cleaner element by following the same steps as for cleaning the air cleaner.
"Cleaning of Air Cleaner" (Page 4-7)

Change of Engine Oil

⚠ Caution

Be careful with hot oil, which could cause burns if it contacts your skin.

Important

When you change the engine oil, be sure to drain it into a bowl and discard it in accordance with local laws and regulations.

Important

Be sure to use engine oil that is classified as JASO DH-2 or API Service Grade CJ-4, with SAE viscosity that is appropriate for the operating environment (ambient temperature).

Important

Securely screw in the oil level gauge and oil filler cap.

Change the engine oil more frequently if the engine oil is contaminated, or if you use the machine in dusty areas or operate the engine at high loads or in high temperatures.

1. Move the machine onto a level surface, stop the engine, remove the drain plug while the engine oil is warm, and then drain the oil into a bowl.
2. Replace the drain plug in the engine.

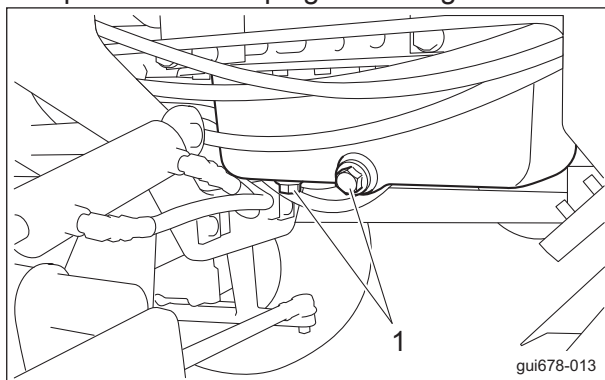

Change of Engine Oil_001

1 Drain plug

3. Through the oil filling port, supply new engine oil until the oil reaches a level in between the upper and lower limit lines on the oil level gauge.
Engine oil quantity is approximately 9.7 dm³ (9.7 L).
4. Replace the oil filler cap.

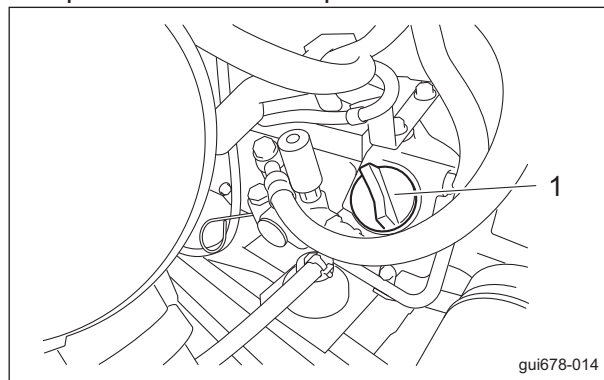

Change of Engine Oil_002

1 Oil filler cap

5. It will take a while for the supplied engine oil to descend into the oil pan.
Check the oil level again 10 to 20 minutes after supplying the oil.
6. Check underneath the machine for oil leakage.

Maintenance

Replacement of Engine Oil Filter

Caution

Be careful with hot oil, which could cause burns if it contacts your skin.

Important

When replacing the engine oil filter, be sure to drain the engine oil into a container and discard it in accordance with local laws and regulations.

Important

Be sure to use engine oil that is classified as JASO DH-2 or API Service Grade CJ-4, with SAE Viscosity that is appropriate for the operating environment (ambient temperature).

Important

Securely tighten the oil level gauge and oil filler cap.

1. With the filter wrench, remove the old filter cartridge.

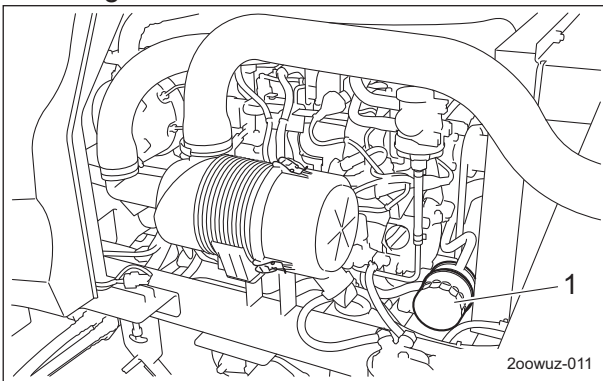

Replacement of Engine Oil Filter_001

1	Filter cartridge
---	------------------

2. Lightly coat the packing of the new filter cartridge with engine oil.
3. Hand-tighten the filter cartridge until the packing contacts the sealing surface, and then firmly hand-tighten (without using a filter wrench).
4. Supply engine oil until it reaches the specified level.
"Supply of Engine Oil" (Page 4-11)
5. Start the engine, and then stop it after 10 to 20 minutes.

6. Make sure that there is no oil leakage at the sealing surface of the filter cartridge.
7. Check the engine oil level.
If it is low, supply engine oil until it reaches the specified level.

Replacement of Fuel Filter

Important

During installation, prevent contamination with dirt or dust.

If the fuel is contaminated with dirt, dust, etc., the fuel injection pump and injection nozzle will become worn.

Since the fuel filter is a cartridge, it cannot be disassembled or cleaned.
If dust or dirt accumulates in the fuel filter, the fuel flow will become insufficient.
Replace the fuel filter at the appropriate times.

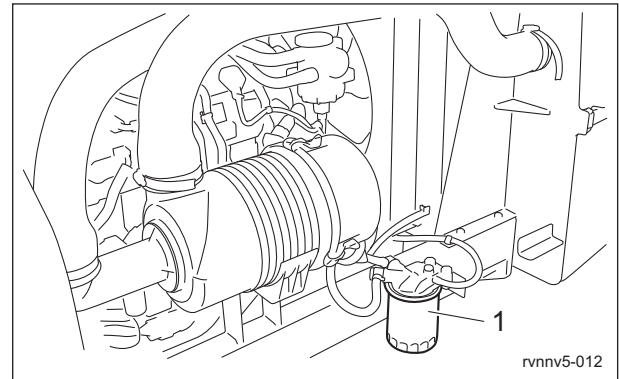

Replacement of Fuel Filter_001

1	Fuel filter
---	-------------

1. Follow the steps below to replace the fuel filter.
[1] Using a filter wrench, remove the fuel filter cartridge.

[2] Lightly coat the packing of the new cartridge with fuel, and then firmly hand-tighten the cartridge, without using the filter wrench.

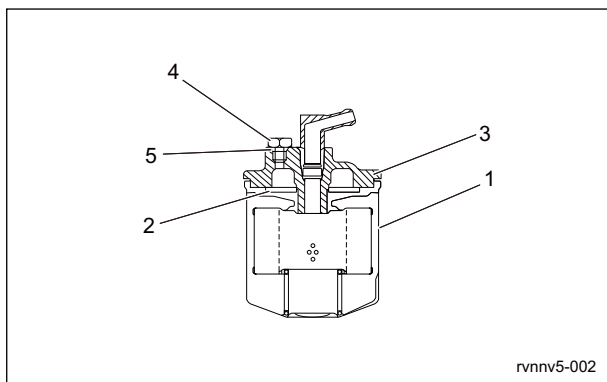

Replacement of Fuel Filter_002

1	Cartridge
2	Packing
3	Cover
4	Air-bleeding plug
5	O-ring

2. Remove air after replacement.

Change of Fuse

Fuse Box

Important

Before performing maintenance on the electrical system, be sure to disconnect the negative terminal of the battery.

Important

If a fuse blows, a short may have occurred within the electrical circuit. Check for the cause, such as faulty terminal connections, damaged wiring or terminals, or incorrect wiring.

The fuse box includes spare fuses and tools.

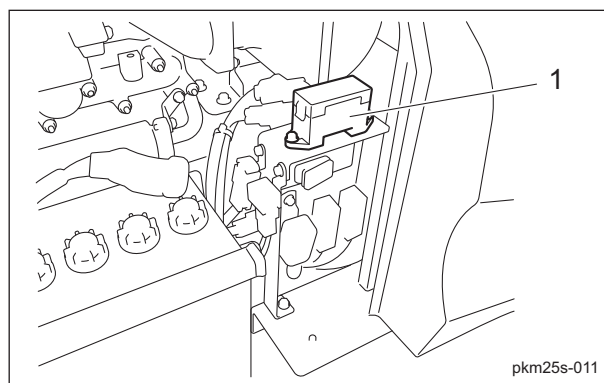

Fuse Box_001

1	Fuse box
---	----------

The machine uses a mini fuse for automobiles.

Replace an old fuse with a new fuse of the specified capacity.

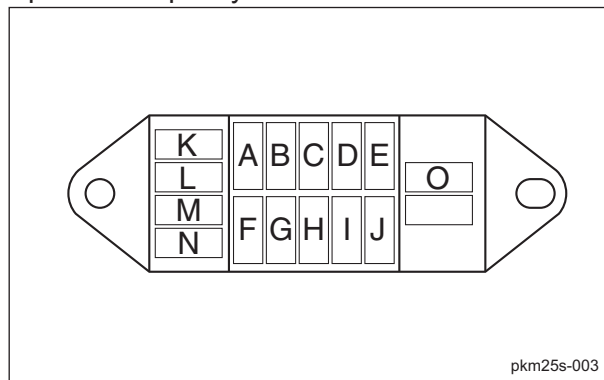

Fuse Box_002

A	5 A	ECU_KeySwitch_ON
B	5 A	Alternator
C	5 A	Display
D	15 A	Relay box 1(differential lock switch, #3 proximity switch, reel rotational direction switch)
E	15 A	Relay box 2 (2WD/4WD selector switch, #4/#5 proximity switches)
F	-	-
G	5 A	ECU_KeySwitch_Start
H	5 A	ECU_Parked Regeneration Switch/Auto Regeneration Inhibit Switch
I	5 A	Operating oil buzzer
J	5 A	Water temperature buzzer
K	5 A	Spare
L	5 A	
M	15 A	
N	15 A	
O		Fuse removal tool

Maintenance

Fusible Link

Fuse capacities of the fusible links are 30 A and 50 A.

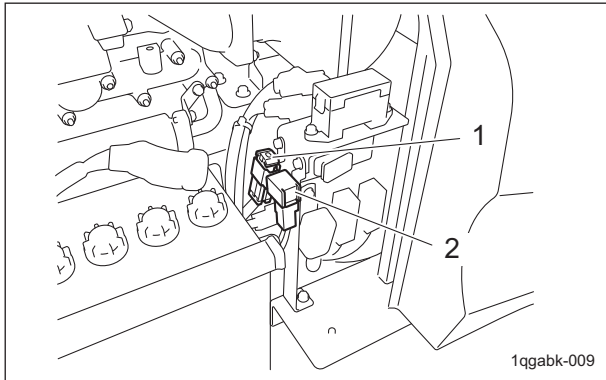

Fusible Link_001

1	Fusible link (50 A)
2	Fusible link (30 A)

EU Declaration of Conformity

Product Identification

Product : Lawnmower
Brand-Name : BARONESS
Type : LM3210A
Starting Serial No. : **11015**
Measured Sound Power Level : LWA 102.80 dB
Guaranteed Sound Power Level : LWA 105 dB
Manufacturer Name : Kyoeshisa Co., Ltd.
Address : 1-26 Miyuki-cho, Toyokawa, Aichi-pref., Japan

Conforms to the following Directives

2006/42/EC Machinery (MD)
2014/30/EU Electromagnetic compatibility (EMC)
2000/14/EC Noise emissions from outdoor equipment

We have been designed and manufactured under the following specifications

ISO 12100 : 2010 (2006/42/EC)
ISO 5395-1 : 2013 (2006/42/EC)
ISO 5395-3 : 2013 (2006/42/EC)
ISO 14982 : 1998 (2014/30/EU)

Keeper of Technical Documentation

Name : Kyoeshisa Co., Ltd.
Address : 1-26 Miyuki-cho, Toyokawa, Aichi-pref., Japan

Compiler of the technical file (2006/42/EC)

Name : Kyoeshisa U.K.Ltd.
Address : Unit 5 Hatch Industrial Park Grewell Road, Basingstoke Hampshire RG24 7NG, the United Kingdom

Conformity assessment procedures

Internal production control : Module A (2006/42/EC)
EC-type examination : Module B (2014/30/EU)
Internal control of production with assessment of technical documentation and periodical checking (2000/14/EC)

Involved Notified Body (2000/14/EC)

Name : TÜV SÜD Industrie Service GmbH
Address : Westendstraße 199 80686 München
Certificate : Notified Body NB0036 according 2000/14/EC

Place : Japan
Date : 20 July 2020 (20 / 7 / 2020)

Signature : 
Name : Akio Hayashi
Position : Quality Dept. Director

(fr)

Déclaration de conformité UE

Identification du produit

Produit : Tondeuse à gazon
Fabriquant : BARONESS
Type : LM3210A
Numéro de série de début : **11015**
Niveau de puissance acoustique mesuré : LwA 102.80 dB
Niveau de puissance acoustique garanti : LwA 105 dB
Fabricant Nom : Kyoeshisa Co., Ltd.
Adresse : 1-26, Miyuki-cho, Toyokawa, préfecture d'Aichi, Japon

Conforme aux directives suivantes :

2006/42/CE Machine (MD)
2014/30/UE Compatibilité électromagnétique (CEM)
2000/14/CE Émissions sonores de l'équipement de plein air

Conception et fabrication en respect des spécifications suivantes :

ISO 12100 : 2010 (2006/42/CE)
ISO 5395-1 : 2013 (2006/42/CE)
ISO 5395-3 : 2013 (2006/42/CE)
ISO 14982 : 1998 (2014/30/UE)

Fiche technique

Marque : Kyoeshisa Co., Ltd.
Adresse de la marque : 1-26, Miyuki-cho, Toyokawa, préfecture d'Aichi, Japon

Compilateur de la fiche technique (2006/42/CE)

Nom : Kyoeshisa U.K. Ltd.
Adresse : Unit 5 Hatch Industrial Park Greywell Road, Basingstoke Hampshire RG24 7NG, Royaume-Uni

Procédures d'évaluation de la conformité

Contrôle de production interne : module A (2006/42/CE)
Examen de type CE : module B (2014/30/UE)
Contrôle interne de la production avec évaluation de la fiche technique et vérification périodique (2000/14/CE)

Organisme notifié impliqué (2000/14/CE)

Nom : TÜV SÜD Industrie Service GmbH
Adresse : Westendstraße 199 80686 München / Munich Deutschland / Germany
N° de certificat : Notified Body NB0036 according 2000/14/EC

Declaración de conformidad de la UE

Identificación del producto

Producto: Cortacésped
 Marca: BARONESS
 Tipo: LM3210A
 N.º de serie inicial: **11015**
 Nivel de potencia sonora medido: LWA 102.80 dB
 Nivel de potencia sonora garantizado: LWA 105 dB
 Fabricante Nombre: Kyoeshia Co., Ltd.
 Dirección: 1-26 Miyuki-cho, Toyokawa, Aichi-pref., Japón

Cumple las siguientes Directivas

2006/42/CE Maquinaria (MD)
 2014/30/UE Compatibilidad electromagnética (EMC)
 2000/14/CE Emisiones sonoras de máquinas de uso al aire libre

Se ha diseñado y fabricado utilizando las siguientes especificaciones

ISO 12100 : 2010 (2006/42/CE)
 ISO 5395-1 : 2013 (2006/42/CE)
 ISO 5395-3 : 2013 (2006/42/CE)
 ISO 14982 : 1998 (2014/30/UE)

Documentación técnica

Nombre del responsable: Kyoeshia Co., Ltd.
 Dirección del responsable: 1-26 Miyuki-cho, Toyokawa, Aichi-pref., Japón

Compilador del archivo técnico (2006/42/CE)

Nombre: Kyoeshia U.K. Ltd.
 Dirección: Unit 5 Hatch Industrial Park Greywell Road, Basingstoke Hampshire RG24 7NG, Reino Unido

Procedimientos de evaluación de conformidad

Control de fabricación interno: Módulo A (2006/42/CE)
 Examen de tipo CE: Módulo B (2014/30/UE)
 Control interno de fabricación con evaluación de documentación técnica y comprobaciones periódicas (2000/14/CE)

Organismo notificado implicado (2000/14/CE)

Nombre: TÜV SÜD Industrie Service GmbH
 Dirección: Westendstraße 199 80686 München / Munich Deutschland / Germany
 Certificado: Notified Body NB0036 according 2000/14/EC

EU-Konformitätserklärung

Produktbeschreibung

Produkt: Rasenmäher
 Marke: BARONESS
 Modell: LM3210A
 Startseriennummer: **11015**
 Gemessener Schalleistungspegel: LWA 102.80 dB
 Garantierter Schalleistungspegel: LWA 105 dB
 Hersteller Name: Kyoeshia Co., Ltd.
 Adresse: 1-26 Miyuki-cho, Toyokawa, Aichi-pref., Japan

Entspricht den folgenden Richtlinien

2006/42/EG Maschinenrichtlinie
 2014/30/EU Elektromagnetische Verträglichkeit (EMV)
 2000/14/EG Geräuschemission von im Freien betriebenen Geräten

Unter Anwendung der folgenden Bestimmungen entwickelt und hergestellt

ISO 12100 : 2010 (2006/42/EG)
 ISO 5395-1 : 2013 (2006/42/EG)
 ISO 5395-3 : 2013 (2006/42/EG)
 ISO 14982 : 1998 2014/30/EU)

Technische Dokumentation

Name des Halters: Kyoeshia Co., Ltd.
 Adresse des Halters: 1-26 Miyuki-cho, Toyokawa, Aichi-pref., Japan

Technische Unterlagen erstellt von (2006/42/EG)

Name: Kyoeshia U.K.Ltd.
 Adresse: Unit 5 Hatch Industrial Park Grewell Road, Basingstoke Hampshire RG24 7NG, Großbritannien

Konformitätsbewertungsverfahren

Interne Produktionskontrolle : Modul A (2006/42/EG)
 EG-Baumusterprüfung : Modul B (2014/30/EU)
 Interne Produktionskontrolle mit Bewertung der technischen Unterlagen und regelmäßiger Überprüfung (2000/14/EG)

Beteiligte benannte Stelle (2000/14/EG)

Name: TÜV SÜD Industrie Service GmbH
 Adresse : Westendstraße 199 80686 München / Munich Deutschland / Germany
 Bescheinigung. : Notified Body NB0036 according 2000/14/EC

EU-försäkran om överensstämmelse

Produktidentifikation

Produkt :	Gräsklippare
Märke:	BARONESS
Typ:	LM3210A
Serienummer startar på:	11015
Uppmätt ljudeffektnivå:	LWA 102.80 dB
Garanterad ljudeffektnivå:	LWA 105 dB
Tillverkare	Namn: Kyoeisha Co., Ltd.
	Adress: 1-26 Miyuki-cho, Toyokawa, Aichi-pref., Japan

Uppfyller följande direktiv

2006/42/EG	Maskindirektivet
2014/30/EU	Elektromagnetisk kompatibilitet (EMC)
2000/14/EG	Bulleremission från utomhusutrustning

Följande kravspecifikationer har följts vid konstruktion och tillverkning

ISO 12100 : 2010 (2006/42/EG)
 ISO 5395-1 : 2013 (2006/42/EG)
 ISO 5395-3 : 2013 (2006/42/EG)
 ISO 14982 : 1998 (2014/30/EU)

Teknisk dokumentation

Innehavarens namn:	Kyoeisha Co., Ltd.
Innehavarens adress:	1-26 Miyuki-cho, Toyokawa, Aichi-pref., Japan

Den tekniska filen(2006/42/EG) har tagits fram av

Namn:	Kyoeisha U.K.Ltd.
Adress:	Unit 5 Hatch Industrial Park Grewell Road, Basingstoke Hampshire RG24 7NG, Storbritannien

Förfarande för bedömning av överensstämmelse

Intern produktionskontroll: Modul A (2006/42/EG)
 EG-typprovning: Modul B (2014/30/EU)
 Intern kontroll av produktion med fastställande av teknisk dokumentation och periodiska kontroller (2000/14/EG)

Anmält organ (2000/14/EG)

Namn:	TÜV SÜD Industrie Service GmbH
Adress:	Westendstraße 199 80686 München / Munich Deutschland / Germany
Certifikat :	Notified Body NB0036 according 2000/14/EC

BARONESS[®]
Quality on Demand

 **KYOEISHA CO., LTD.**
Head Office 1-26, Miyuki-cho, Toyokawa-city, Tel :+81-533-84-1390
Aichi-pref, 442-8530 JAPAN Fax:+81-533-84-1220