

# ***GM2810A***

5-Unit Rotary Mower

## Owner's Operating Manual

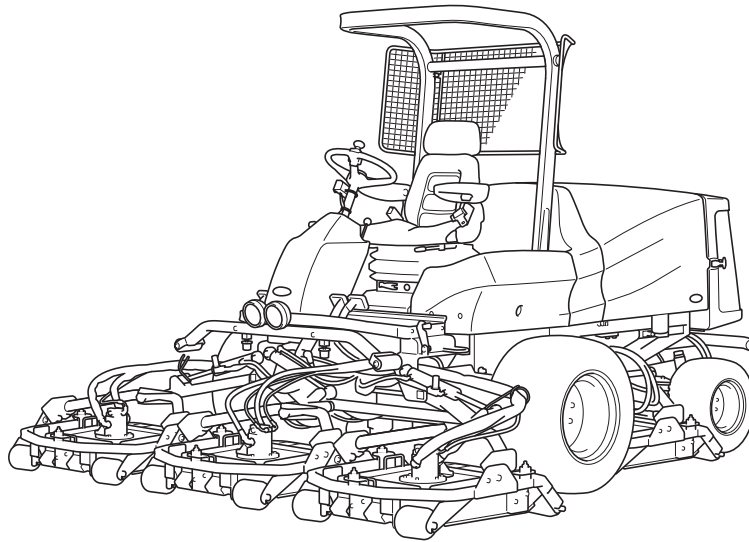

Serial No. GM2810A : 11132-

"Required reading"  
Read this manual before using the machine.

---

**BARONESS**<sup>®</sup>  
Quality on Demand

Original Instructions Ver.1.2

# Regulations

## California Proposition 65

(For California, USA)

### WARNING:

Operating, servicing and maintaining a passenger vehicle or off-road vehicle can expose you to chemicals including engine exhaust, carbon monoxide, phthalates, and lead, which are known to the State of California to cause cancer and birth defects or other reproductive harm. To minimize exposure, avoid breathing exhaust, do not idle the engine except as necessary, service your vehicle in a well-ventilated area and wear gloves or wash your hands frequently when servicing your vehicle. For more information go to [www.P65Warnings.ca.gov/passenger-vehicle](http://www.P65Warnings.ca.gov/passenger-vehicle).

318yi8-005

California Proposition 65\_001

## California Spark Arrester

(For California, USA)

### Warning

Operation of this equipment may create sparks that can start fires around dry vegetation.  
A spark arrester may be required.  
The operator should contact local fire agencies for laws or regulations relating to fire prevention requirements.

The DPF installed on the engine of this machine meets requirements of California Public Resource Code Section 4443.

## EU Emission Control (Stage V)

(For Europe)

### Important

No deliberate tampering with or misuse of the engine emissions control system should take place.

Make repairs immediately if the fault codes of PCD (Particulate Control Diagnostic) and NCD (NOx Control Diagnostic) appear.

Tampering with and use without effect of the engine emissions control system are regulatory infringements and they are penalized.

Thank you for purchasing the Baroness product.  
This manual describes the proper handling,  
adjustment, and inspection of your product.  
We hope you will use the product safely, and take  
advantage of its best performance.

## Keeping The Owner's Operating Manual

Keep this Manual in the bag located in the rear of the seat.

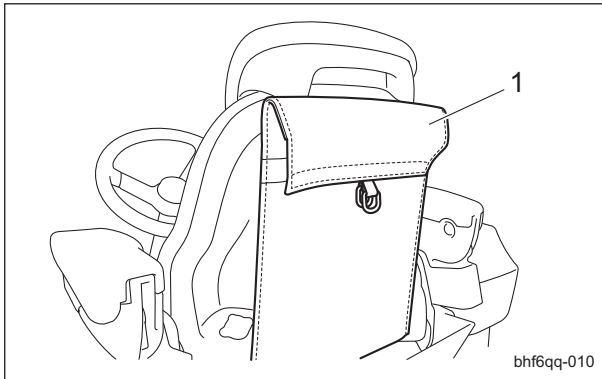

Keeping The Owner's Operating Manual\_001

1	Bag
---	-----

# Introduction

Read this manual carefully to ensure that you thoroughly understand how to properly operate and maintain the product, and to avoid causing injury to yourself or others.

The operator is responsible for operating the product properly and safely.

Maintenance service for this machine should be performed by a mechanic with expertise.

If you have any questions concerning maintenance or genuine parts, please contact a Baroness dealer or Kyoisha.

When making inquiries about the product, please specify the product's model designation and serial number.

When loaning or transferring the product, please also provide this manual together with the product.

Kyoisha Co., Ltd.

## Warning Symbols

This manual uses the following warning symbols for handling precautions that are important for your safety.



696cq5-001

Warning symbol

This symbol indicates the articles regarding “Danger,” “Warning,” or “Caution.”

Those articles describe important safety precautions and so read them carefully to understand completely before operating the machine.

Failure to adequately follow these safety precautions may cause an accident.

### **Danger**

This symbol indicates that serious injury or death will occur if the warning is ignored.

### **Warning**

This symbol indicates that serious injury or death may occur if the warning is ignored.

### **Caution**

This symbol indicates that injury or damage to property may occur if the warning is ignored.

### **Important**

This symbol indicates precautions on the mechanism of the machine.

## Precautionary Statement

 Caution

The information described in this manual is subject to change for improvement without prior notice.

When replacing parts, be sure to use genuine Baroness parts or parts designated by Kyoisha.

Note that the Baroness product warranty may not apply to defects caused by the use of parts from other companies.

Prior to use, carefully read the following manuals to thoroughly understand the contents for safe and correct operation.

- Baroness Owner's Operating Manual
- The Engine's Owner's Manual
- The Battery's Owner's Manual

## Purpose

This product is intended for cutting turf grass at golf courses.

Do not use this product in any way other than its intended purpose, and do not modify this product.

Operating this product for other purposes and modifying it may be very dangerous and may cause damage to the product.

In addition, this product is not authorized for operation as a special motor vehicle. Do not operate it on public roads.

GM2810A

# Introduction

---

<b>Safety</b> .....	<b>Page 1-1</b>
Safe Operating Practices .....	Page 1-2
<b>Disposal</b> .....	<b>Page 2-1</b>
Recycle and Waste Disposal .....	Page 2-2
<b>Product Overview</b> .....	<b>Page 3-1</b>
Specifications .....	Page 3-2
Names of Each Section .....	Page 3-4
Regulation Decals .....	Page 3-5
Safety Signs and Instruction Signs .....	Page 3-8
<b>Handling Instructions</b> .....	<b>Page 4-1</b>
Inspections .....	Page 4-2
Tightening Torques .....	Page 4-14
Adjustment before Work .....	Page 4-19
Procedure to Start/Stop Engine .....	Page 4-22
Operation Method .....	Page 4-24
Instruments .....	Page 4-36
Move .....	Page 4-72
Cutting Work .....	Page 4-73
Transporting .....	Page 4-74
Storage .....	Page 4-74
<b>Maintenance</b> .....	<b>Page 5-1</b>
Maintenance Precautions .....	Page 5-2
Maintenance Schedule .....	Page 5-2
DPF .....	Page 5-8
Jacking Up The Machine .....	Page 5-20
Greasing .....	Page 5-21
Lubrication .....	Page 5-24
Maintenance Work .....	Page 5-25

GM2810A

# Contents

---



**Safe Operating Practices ..... Page 1-2**

Training ..... Page 1-2

Preparation ..... Page 1-2

Operation ..... Page 1-3

Maintenance ..... Page 1-4

Storage ..... Page 1-5



# Safety

Failure to adequately follow these safety precautions may cause an accident resulting in injury or death.

## Danger

This product is designed to ensure safe operation and has been tested and inspected thoroughly before shipment from the factory. The product is equipped with safety devices to prevent accidents.

However, whether the product demonstrates its original performance level depends on the manner in which it is operated and handled, as well as the manner in which it is managed on a daily basis.

Inappropriate use or management of the product may result in injury or death.

Observe the following safety instructions to ensure safe operation.

## Safe Operating Practices

### Training

1. Read this manual and other training material carefully.

Be familiar with the controls, safety signs, and the proper use of the equipment.

2. If the operator or mechanic can not read the language used in this manual, it is the owner's responsibility to explain this material to them.

3. All operators and mechanics should seek and obtain professional and practical instruction.

The owner is responsible for training the users.

Such instruction should emphasize:

- [1] The need for care and concentration when working with ride-on machines.

- [2] Control of a ride-on machine sliding on a slope will not be regained by the application of the brake.

The main reasons for loss of control are

- Insufficient wheel grip
- Being driven too fast
- Inadequate braking
- The type of machine is unsuitable for its task
- Lack of awareness of the effect of ground conditions, especially slopes
- Incorrect hitching and load distribution

4. Never allow children or people unfamiliar with these instructions to use or service the machine.

Local regulations may restrict the age of the operator.

5. The owner/user can prevent and is responsible for accidents or injuries occurring to themselves, other people, or property.
6. Keep in mind that the owner, operator, and mechanic are responsible for accidents or hazards occurring to other people or their property.
7. The ROPS is an integral and effective safety device.  
Do not remove or alter the ROPS.
8. Replace a damaged ROPS.  
Do not repair or alter.
9. You can find additional safety information where needed throughout this manual.
10. Determine the left and right sides of the machine from the normal operating position.

### Preparation

1. Evaluate the terrain to determine what accessories and attachments are needed to properly and safely perform the job.  
Only use accessories and attachments approved by the manufacturer.
2. While operating, always wear substantial footwear, long trousers, hard hat, safety glasses, mask, and ear protection.  
Long hair, loose clothing, or jewelry may get tangled in moving parts.  
Do not operate the equipment when barefoot or wearing open sandals.
3. Inspect the area where the equipment is to be used and remove all objects such as rocks, toys and wire which can be thrown by the machine.
4. Keep children out of the operating area and under the watchful care of a responsible adult other than the operator.
5. Exercise care in the handling of fuel.

## Warning

Fuel is highly flammable.

Take the following precautions:

- [1] Store fuel in containers specifically designed for this purpose.

- [2] Add fuel before starting the engine.  
Never remove the cap of the fuel tank or add fuel while the engine is running or when the engine is hot.
- [3] Refuel outdoors only and do not smoke while refueling.
- [4] If fuel is spilled, do not attempt to start the engine but move the machine away from the area of spillage and avoid creating any source of ignition until petrol vapours have dissipated;
- [5] Replace all fuel tanks and container caps securely.
6. Check that operator's presence controls, safety switches and shields are attached and functioning properly.  
Do not operate unless they are functioning properly.
7. If the brake operation is faulty, be sure to adjust or repair them before operating the machine.
8. Replace faulty mufflers.
9. Before using, always visually inspect to see that the rotary knives, rotary knife bolts, and cutter assembly are not worn or damaged.  
Replace worn or damaged rotary knives and bolts in sets to preserve balance.
10. On multi-rotary knife machines, take care as rotating one rotary knife can cause other rotary knives to rotate.
5. Never operate the machine with damaged guards, shields, or without safety protective devices in place.  
Be sure all interlocks are attached, adjusted properly, and functioning properly.
6. Keep hands and feet away from the rotating parts.
7. Do not carry passengers.
8. Never operate while people, especially children, or pets are nearby.
9. Only operate in good light, keeping away from holes and hidden hazards.
10. Do not operate the machine when there is the risk of lightning.
11. Do not stop or start suddenly.
12. Look behind and down before backing up to be sure of a clear path.
13. Slow down and use caution when making turns and crossing roads and sidewalks.
14. Use care when approaching blind corners, shrubs, trees, or other objects that may obscure vision.
15. Do not take your eyes off the road ahead.  
Do not operate the machine with no hands.
16. Remember there is no such thing as a safe slope.  
Travel on grass slopes requires particular care.  
To guard against overturning, follow these instructions.

## Operation

1. Do not operate the machine under the influence of alcohol or drugs.
2. Do not operate the engine in a confined space where dangerous carbon monoxide fumes can collect.
3. Be sure all drives and shift are in neutral and parking brake is engaged before starting engine.  
Only start engine from the operator's position.  
Use seat belts if provided.
4. Do not change the engine governor settings or overspeed the engine.  
Operating the engine at excessive speed may increase the hazard of personal injury.
- [1] Do not stop or start suddenly when going up or downhill.
- [2] Engage clutch slowly, always keep machine in gear, especially when traveling downhill.
- [3] Machine speeds should be kept low on slopes and during turns.
- [4] Stay alert for humps and hollows and other hidden hazards.
17. Never use the machine on a slope with an angle of gradient that is greater than that specified or in a place where there is a danger of the machine slipping.
18. Use extra care while operating machine with a grass catcher or other attachments.  
They can affect the stability of the machine.
19. Disengage drive to the cutting unit(s), when other than operating.

# Safety

---

20. Do the following before leaving the operator's position.
  - [1] Stop on level ground.
  - [2] Disengage the all drives.
  - [3] Set the parking brake.
  - [4] Stop the engine.
  - [5] Remove the ignition key.
21. Stop the engine in the following conditions.
  - [1] Before refuelling.
  - [2] Before making height or depth adjustment unless adjustment can be made from the operator's position.
  - [3] Before clearing blockages.
  - [4] Before checking, cleaning or working on the machine.
  - [5] After striking a foreign object or if an abnormal vibration occurs.  
Inspect the machine for damage and make repairs before restarting and operating the equipment.
22. Reduce the throttle setting during engine run-out.
23. Never raise mower deck with the rotary knives running.
24. Do not mow in reverse unless absolutely necessary.
25. Do not direct discharge material toward anyone.  
Avoid discharging material against a wall or obstruction.  
Material may ricochet back toward the operator.
26. Take care when loading or unloading the machine into a trailer or a truck.  
Load or unload the machine in a flat and safe place.  
Before loading or unloading, set the parking brake on the truck or trailer, stop the engine, and chock the wheels.  
When transporting the machine on a truck or a trailer, set the parking brake, stop the engine, and fasten the machine to the truck with a rope or other suitable restraining device that has sufficient strength.  
When using a running board, select one with sufficient strength, length, and width and that will not cause the machine to slip.
27. Close the fuel valve before transporting the machine.

## Maintenance

1. Never allow untrained personnel to service machine.
2. Implement the following work before adjusting, cleaning or repairing.
  - [1] Stop the machine on level ground.
  - [2] Disengage drive to the cutting unit(s).
  - [3] Lower the cutting unit(s) and attachment(s) if installed.
  - [4] Set the parking brake.
  - [5] Stop the engine.
  - [6] Remove the ignition key.
  - [7] Wait for all movement to stop.
3. Allow the engine/muffler to cool before checking/maintenance.
4. To reduce the fire hazard, keep hot parts such as the engine and silencer/muffler, battery compartment and fuel storage area free of grass, leaves, or excessive grease.  
Clean up oil or fuel spillage.
5. Appropriately manage and correctly use the tools necessary for servicing or adjusting the machine.
6. Disconnect battery before making any repairs.  
Disconnect the negative terminal first and the positive last.  
Reconnect positive first and negative last.
7. Use jack stands to support components when required.
8. Keep hands and feet away from moving parts.  
If possible, do not make adjustments with the engine running.
9. Make sure that parts such as wires are not touching each other and that their covers have not come off.
10. Keep all parts in good working condition and all hardware tightened.  
Replace all worn or damaged decals.
11. Keep all nuts, bolts and screws tight to be sure the equipment is in safe working condition.
12. Carefully release pressure from components with stored energy.
13. Be sure to depressurize the hydraulic system before performing maintenance operations on it such as removing hydraulic equipment.

14. Check whether line connectors in the hydraulic system are properly tightened. Before applying hydraulic pressure, check the connections of the hydraulic pressure lines and the condition of the hoses.
  15. When checking the hydraulic circuit for pinhole leaks or oil leakage from nozzles, do not use your hands.  
Use items such as paper or corrugated cardboard to find leakage points.  
Be extremely careful with high-pressure oil as it may pierce your skin, resulting in an injury.  
If fluid is injected into the skin it must be surgically removed within a few hours by a doctor familiar with this form of injury or gangrene may result.
  16. Use care when checking the rotary knives. Wrap the rotary knives or wear gloves, and use caution when servicing them.  
Only replace rotary knives.  
Never straighten or weld them.
  17. On multi-rotary knife machines, take care as rotating one rotary knife can cause other rotary knives to rotate.
  18. Charge batteries in an open well ventilated area, away from spark and flames.  
Unplug charger before connecting or disconnecting from battery.  
Wear protective clothing and use insulated tools.
  19. If the fuel tank has to be drained, do this outdoors.
7. Swallowing engine coolant can cause injury or death; keep out of reach from children and pets.

## Storage

1. When machine is to be parked, stored, or left unattended, lower the cutting unit(s) and attachment(s) if installed unless a positive mechanical lock is provided.
2. Allow the engine to cool before storing in any enclosure.
3. Only cover the machine with a sheet after hot parts have sufficiently cooled down.
4. Never store the equipment with fuel in the tank inside a building where fumes may reach an open flame or spark.
5. If the engine is provided with a shut-off valve, shut off valve while storing or transporting.
6. Do not store fuel near flames.



**Recycle and Waste Disposal ..... Page 2-2**

About Recycle .....Page 2-2

About Waste Disposal ..... Page 2-2

# Disposal

---

## Recycle and Waste Disposal

### About Recycle

Recycling battery etc. is recommended for environmental conservation and economical use of resources.

It may be required by local laws.

### About Waste Disposal

Make sure that waste generated when servicing or repairing the machine is disposed of in accordance with local regulations. (e.g. waste oil, antifreeze, rubber products, and wires etc.)



<b>Specifications .....</b>	<b>Page 3-2</b>
Specifications .....	Page 3-2
Sound Pressure Level .....	Page 3-3
Sound Power Level .....	Page 3-3
Vibration Level .....	Page 3-3
Carbon Dioxide (CO <sub>2</sub> ) Emissions Measurement .....	Page 3-4
<b>Names of Each Section .....</b>	<b>Page 3-4</b>
<b>Regulation Decals .....</b>	<b>Page 3-5</b>
Positions of Regulation Decals .....	Page 3-5
Description of Regulation Decals .....	Page 3-5
<b>Safety Signs and Instruction Signs .....</b>	<b>Page 3-8</b>
About Safety Signs and Instruction Signs .....	Page 3-8
Positions of Safety Signs and Instruction Signs .....	Page 3-8
Description of Safety Decals and Instruction Decals .....	Page 3-10

# Product Overview

## Specifications

### Specifications

Model		GM2810A	
Dimensions	Total length		145.67 in 370 cm
	Total width	During operation	118.11 in 300 cm
		During transport	90.55 in 230 cm
	Total height	Roof	90.55 in 230 cm
Steering wheel		64.96 in 165 cm	
Weight	Machine (empty fuel tank)	with ROPS, Roof	4585.54 lb 2,080 kg
Minimum turning radius		125.98 in 320 cm	
Engine	Model		Kubota V2403-CR-TE5B
	Type		Vertical water-cooled 4-cycle diesel engine with turbocharger
	Total displacement		148.51 cu.in. 2,434 cm <sup>3</sup> (2.434 L)
	Maximum output		43.2 kW (58.7 PS)/2,400 rpm
Fuel tank capacity		Diesel 13.47 U.S.gals Diesel 51.0 dm <sup>3</sup> (51.0 L)	
Fuel consumption		182 g/PS · h (rated output) 248 g/kW · h (rated output)	
Engine oil capacity		2.56 U.S.gals 9.7 dm <sup>3</sup> (9.7 L)	
Coolant volume		3.17 U.S.gal. 12.0 dm <sup>3</sup> (12.0 L)	
Hydraulic tank capacity		11.62 U.S.gal. 44.0 dm <sup>3</sup> (44.0 L)	
Operating width (Mowing width)		110.24 in 280 cm	
Operating height (Mowing height)		0.787 - 3.602 in 20.0 - 91.5 mm	
Blades		5	
Drive	Traveling		HST (2WD/4WD selectable)
	Mowing		Hydraulic
Speed (HST)	Forward		0 - 9.94 mph 0 - 16.0 km/h
	Reverse		0 - 3.73 mph 0 - 6.0 km/h
Speed (Mechanical)		-	
Efficiency		4.98 acres/hour (5.59 mph x mowing width x 0.8) 20,160 m <sup>2</sup> /h (9.0 km/h x mowing width x 0.8)	
Maximum inclination for operation		15 degrees	
Tire size	Front wheel		29 x 14.00 - 15
	Rear wheel		20 x 12.00 - 10
Tire pneumatic pressure	Front wheel		21.75 psi 150 kPa (1.5 kgf/cm <sup>2</sup> )
	Rear wheel		20.30 psi 140 kPa (1.4 kgf/cm <sup>2</sup> )
Battery		105D31R	
Engine plug		-	

\* The factory default maximum engine rpm is 2,600 rpm.

## Sound Pressure Level

### Sound Pressure Level

This machine was confirmed to have a continuous A-weighted sound pressure level of 90dB by measuring identical machines in accordance with the procedure specified in ISO 5395-1:2013.

## Sound Power Level

### Sound Power Level

This machine was confirmed to have a sound power level of 105dB by measuring identical machines in accordance with the procedure specified in ISO5395-1:2013.

## Vibration Level

### Hand-Arm Vibration

This machine was confirmed not to exceed a vibration level of  $2.5 \text{ m/s}^2$  to hands and arms by measuring identical machines in accordance with the procedure specified in ISO 5395-1:2013.

### Whole Body Vibration

This machine was confirmed not to exceed a vibration level of  $0.5 \text{ m/s}^2$  to the whole body by measuring identical machines in accordance with the procedure specified in ISO 5395-1:2013.

# Product Overview

## Carbon Dioxide (CO<sub>2</sub>) Emissions Measurement

For CO<sub>2</sub> emissions measurement on the engine of this machine, refer to the engine's owner's manual.

### Names of Each Section

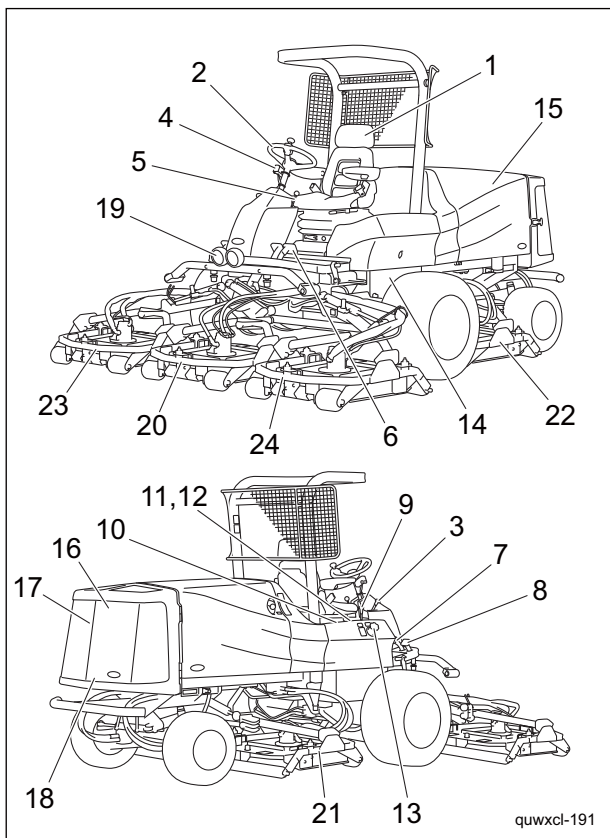

Names of Each Section\_001

1	Seat
2	Steering handle
3	Tilt lever
4	Diff-lock switch
5	Parking brake lever
6	Brake pedal
7	Forward pedal
8	Reverse pedal
9	Mower deck up/down lever
10	Throttle knob
11	Knife rotation switch
12	2WD/4WD selector switch
13	Fuel tank
14	Hydraulic tank
15	Hood
16	Radiator
17	Oil cooler
18	Radiator cover
19	Light
20	Mower deck #1
21	Mower deck #2
22	Mower deck #3
23	Mower deck #4
24	Mower deck #5

## Regulation Decals

### Positions of Regulation Decals

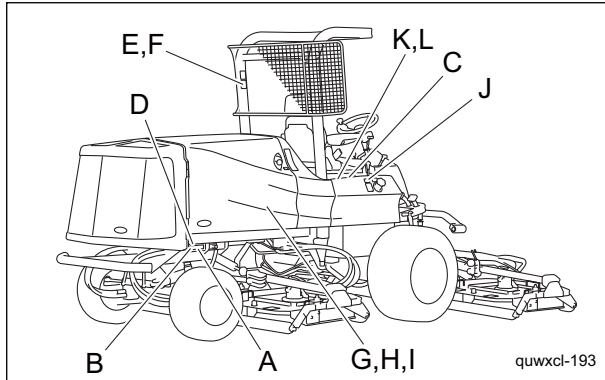

Positions of Regulation Decals\_001

A	Serial number plate
B	Specification decal
C	Noise emission decal
D	Year of manufacture decal
E	ROPS compliance decal
F	ROPS caution decal
G	Battery capacity decal
H	Recycle decal
I	Battery danger decal
J	Indicating diesel fuel decal
K	California proposition 65 decal (riding type)
L	Spark arrester warning decal

### Description of Regulation Decals

#### Serial Number Plate

The serial number plate indicates the model and serial number of the machine.

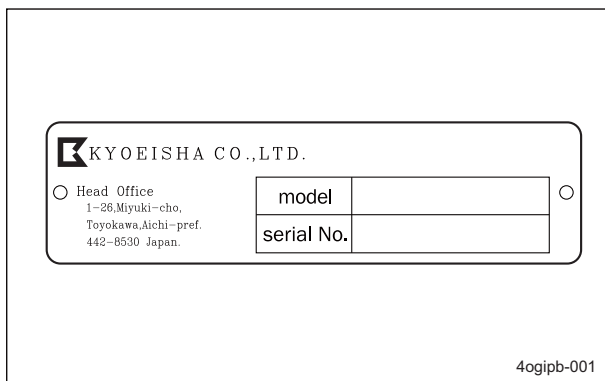

Serial Number Plate\_001

#### Specification Decal

(For Europe)

CE mark indicates that the machine sold in the EU nations complies with the EU requirements.

The Specification decal indicates the CE marking, model, and weight, etc.

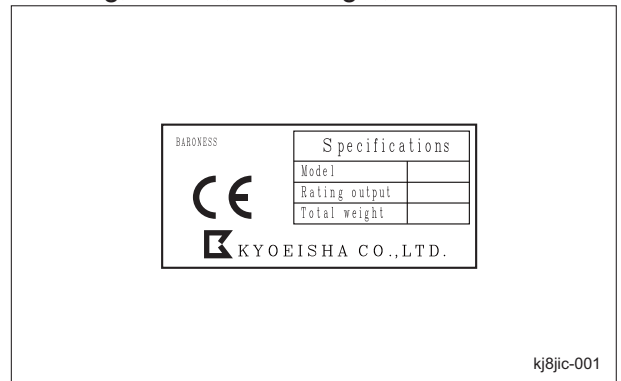

Specification Decal\_001

#### Noise Emission Decal

(For Europe)

The noise emission decal indicates the sound power level determined by measuring identical machines in accordance with the procedure specified in the EC directives.

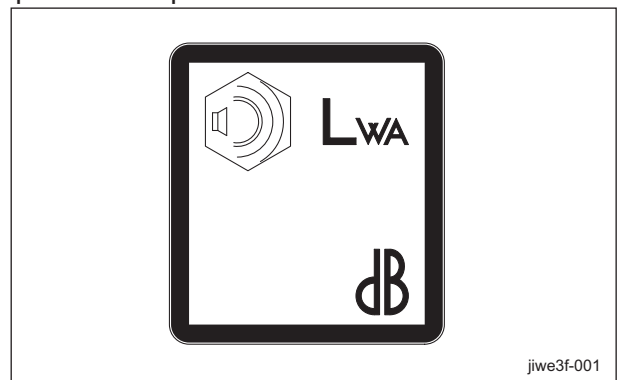

Noise Emission Decal\_001

# Product Overview

## Year of Manufacture Decal

(For Europe)  
The year of manufacture decal indicates the year when this machine was manufactured.



Year of Manufacture Decal\_001

## Battery Capacity Decal

(For Europe)  
The battery capacity decal indicates the capacity by 20HR and CCA.

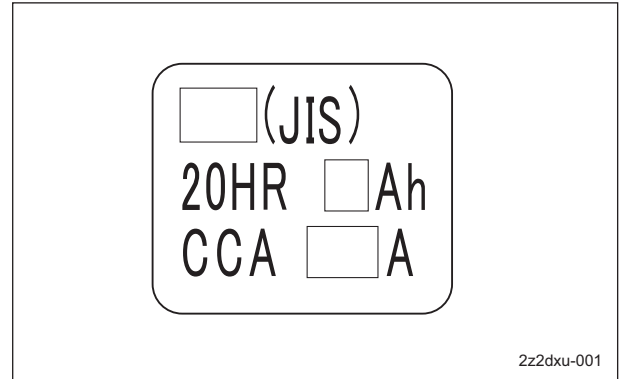

Battery Capacity Decal\_001

## ROPS Compliance Decal

The ROPS compliance decal indicates the manufacturer, model, etc., in accordance with International Standard ISO 21299:2009.

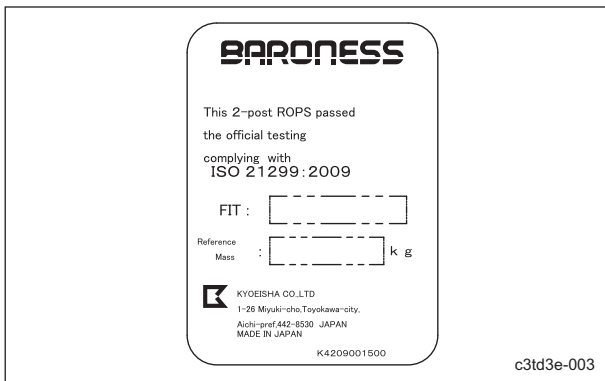

ROPS Compliance Decal\_001

## Recycle Decal

Recycle Decal illustrates Recycle Mark in accordance with local regulation.  
(For Europe)

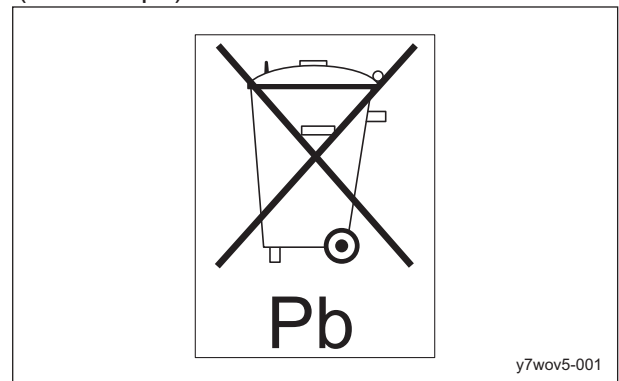

Recycle Decal\_001

## ROPS Caution Decal

ROPS caution decal describes the following caution messages.

- Replace damaged ROPS.
- Do not repair or revise.

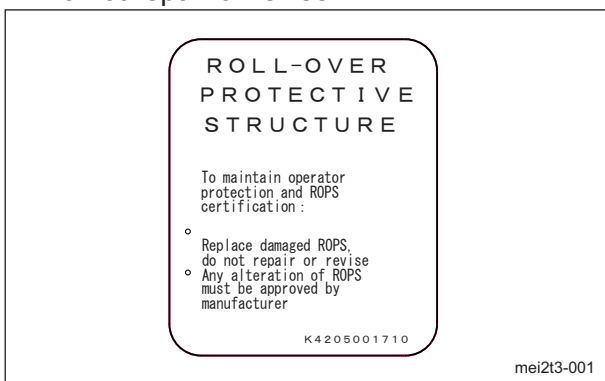

ROPS Caution Decal\_001

(For USA)



Recycle Decal\_002

## Battery Danger Decal

(For USA)

Battery Danger Decal describes handling precautions for battery.



Battery Danger Decal\_001

## California Proposition 65 Decal (Riding Type)

(For the State of California, USA)

California Proposition 65 decal describes the warning messages as required by California Proposition 65.

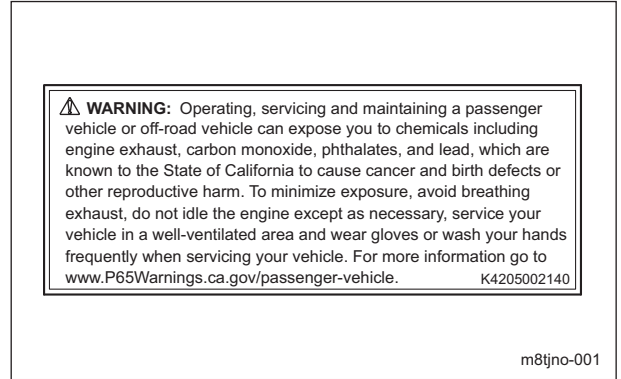

California Proposition 65 Decal (Riding Type)\_001

## Indicating Diesel Fuel Decal

(For USA)

Indicating diesel fuel decal describes the type of fuel to be used.

Use Ultra Low Sulfur Diesel Fuel (sulfur-free diesel).

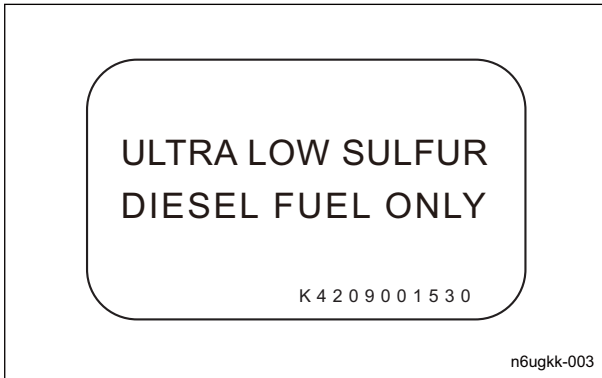

Indicating Diesel Fuel Decal\_001

## Spark Arrester Warning Decal

(For the State of California, USA)

Spark arrester warning decal describes the warning messages as required by California Public Resources Code.

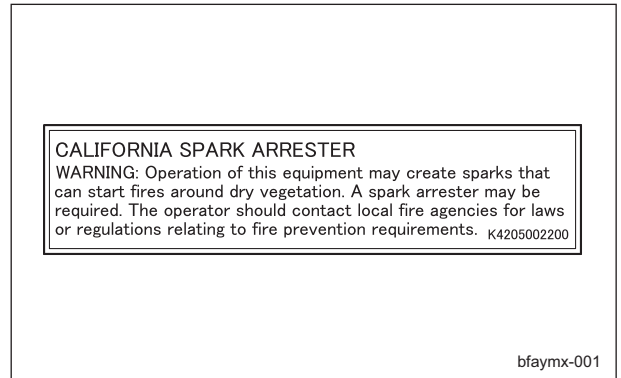

Spark Arrester Warning Decal\_001

# Product Overview

## Safety Signs and Instruction Signs

### About Safety Signs and Instruction Signs

**Important**

Safety decals and instruction decals are attached to this product. Make sure that they are preserved in their entirety. If they are damaged, become dirty, or peel off, replace them with new ones.

Part numbers for decals that need to be replaced are listed in the parts catalog. Order them from a Baroness dealer or Kyoeshia.

### Positions of Safety Signs and Instruction Signs

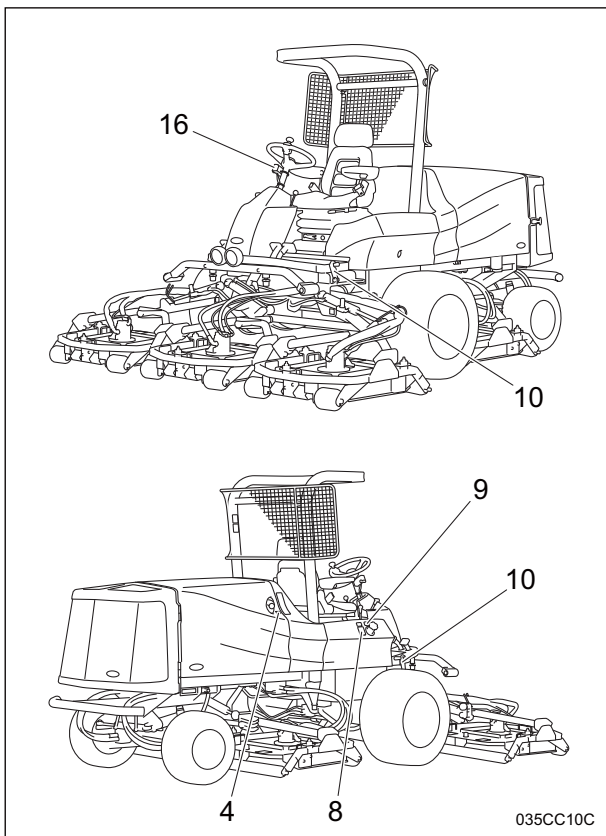

Positions of Safety Signs and Instruction Signs\_001

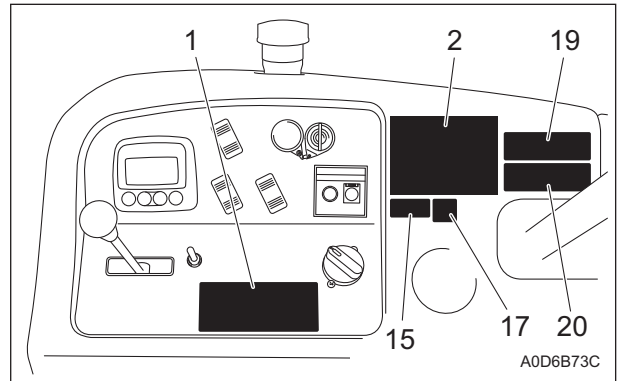

Positions of Safety Signs and Instruction Signs\_002

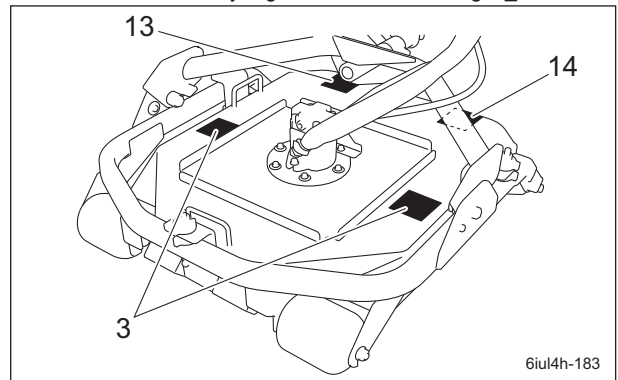

Positions of Safety Signs and Instruction Signs\_003

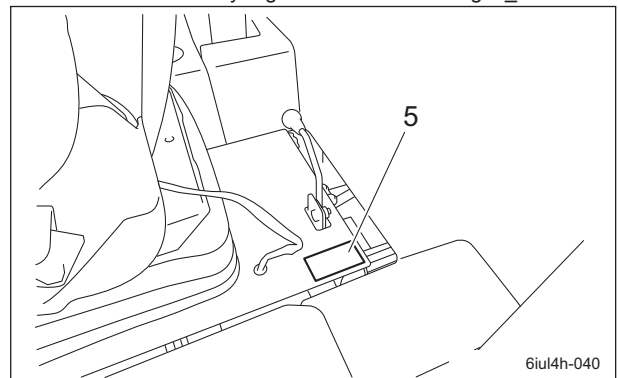

Positions of Safety Signs and Instruction Signs\_004

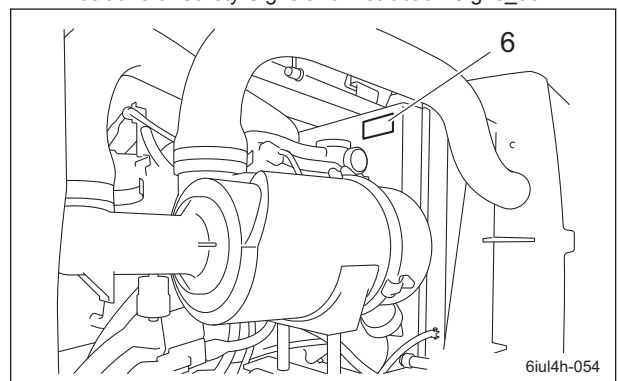

Positions of Safety Signs and Instruction Signs\_005



# Product Overview

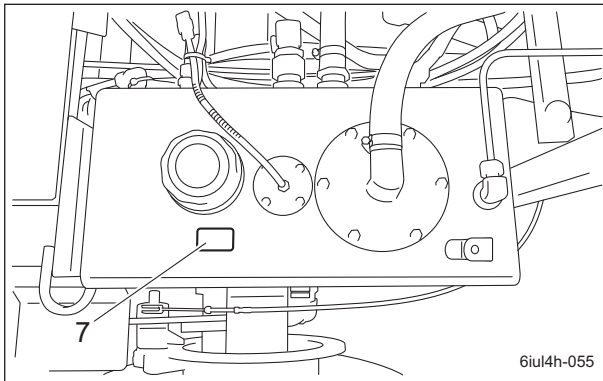

Positions of Safety Signs and Instruction Signs\_006

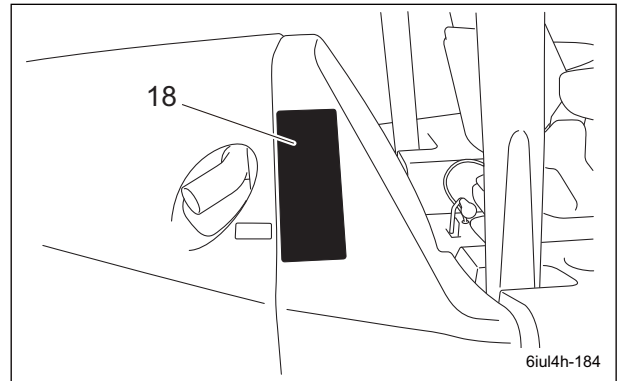

Positions of Safety Signs and Instruction Signs\_010

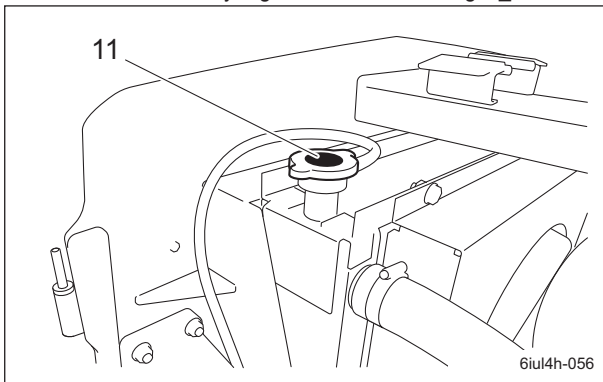

Positions of Safety Signs and Instruction Signs\_007

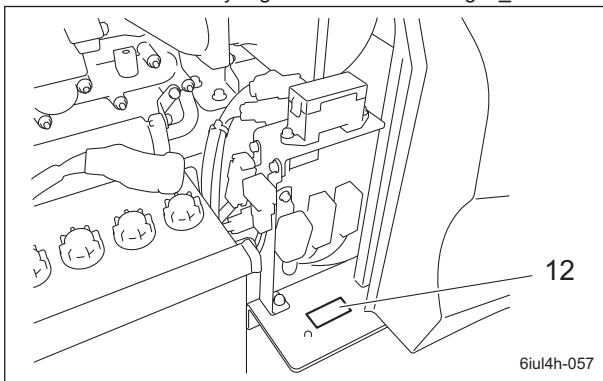

Positions of Safety Signs and Instruction Signs\_008

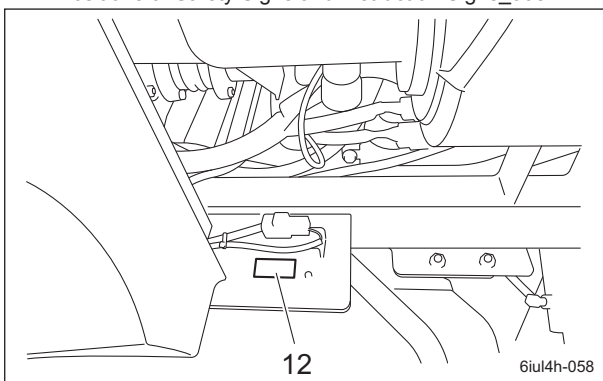

Positions of Safety Signs and Instruction Signs\_009

1	Operation decal
2	Engine start/stop decal
3	Caution to mutilation decal
4	Caution for high temperatures decal
5	Caution to injury decal
6	Caution to rotating object decal
7	Hydraulic oil icon
8	Diesel fuel icon
9	Fire prohibited decal
10	Caution for mower lock decal
11	Caution for spouting coolant decal
12	Caution to getting pinched decal
13	Caution to flying object decal
14	Caution for hand or leg injury decal
15	Caution exhaust gas decal
16	Engine warning lamp decal (EN)
17	Caution to noise decal
18	Maintenance decal
19	2WD/4WD selector important decal
20	20 Knife rotation important decal

# Product Overview

## Description of Safety Decals and Instruction Decals

### Operation Decal

GM2810A0902Z0

Decal, operation

1.

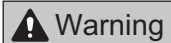

**Warning**

Read the Owner's Operating Manual.

2.

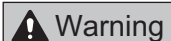

**Warning**

Apply the parking brake, stop the engine, remove the ignition key, and then leave the machine.

3.

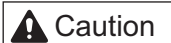

**Caution**

Flying objects - Be sure that people around the machine keep a safe distance away.

4.

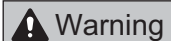

**Warning**

May cut your hand or leg - Keep hands and feet away from moving parts.

5.

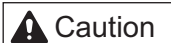

**Caution**

Rollover - Do not work on slopes of 15 degrees or more.  
When you descend a slope, lower the mower decks and then drive at low speed.  
For ROPS equipped machine, fasten your seatbelt.

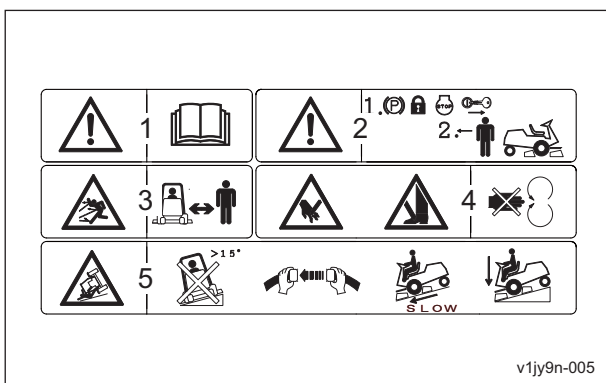

Operation Decal\_001

### Engine Start/Stop Decal

K4205001630

Decal, start/stop engine

1.



**Warning**

Read the Owner's Operating Manual.

2. Procedure to Start Engine

Read the Owner's Operating Manual.

[1] Sit on the seat.

[2] Turn the key to the "ON (GLOW)" position, and then wait for the logo "BARONESS" to be turned off.

[3] Turn the key to the "START" position.

[4] Depress the brake pedal to release the parking brake.

3. Procedure to Stop Engine

Read the Owner's Operating Manual.

[1] Set the knife rotation switch to the "Stop" position, and then raise the mower decks.

[2] Apply the parking brake.

[3] Turn the key to the "STOP" position, and then remove it.

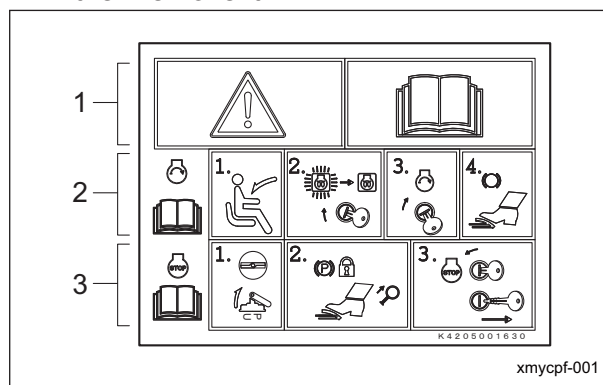

Engine Start/Stop Decal\_001

### Caution to Mutilation Decal

K4205001600  
DECAL, CAUTION TO MUTILATION

**Warning**

May cut your hand or leg - Stop the cutter rotation and engine. Otherwise you may get injured.

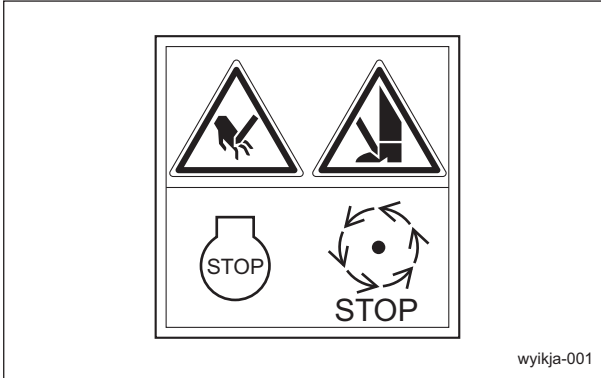

Caution to Mutilation Decal\_001

### Caution to Injury Decal

K4205001580  
Decal, caution to injure

**Caution**

May pinch - There is a risk of being pinched.

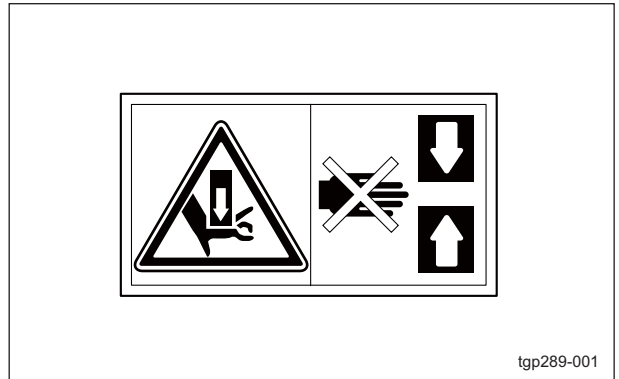

Caution to Injury Decal\_001

tgp289-001

### Caution for High Temperatures Decal

K4205001920  
Decal, caution for high temperatures

**Caution**

High temperature - Do not touch. Otherwise, you will get burned.



Caution for High Temperatures Decal\_001

xekv4l-001

### Caution to Rotating Object Decal

K4205001530  
Decal, caution to rotating object

**Warning**

Watch for rotating parts - Keep your hands away from the belts while the engine is running.

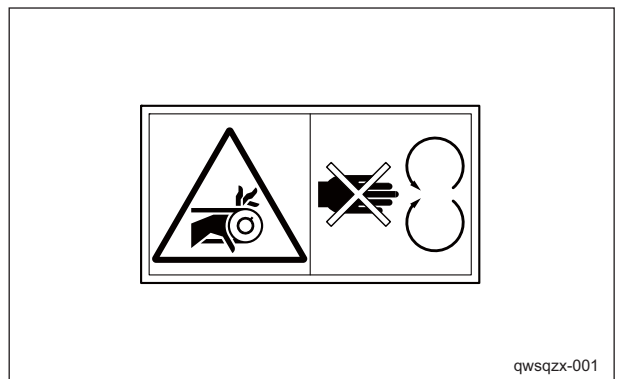

Caution to Rotating Object Decal\_001

qwsqzx-001

# Product Overview

## Hydraulic Oil Icon

K4209000980  
Hydraulic oil icon  
Read the Owner's Operating Manual.

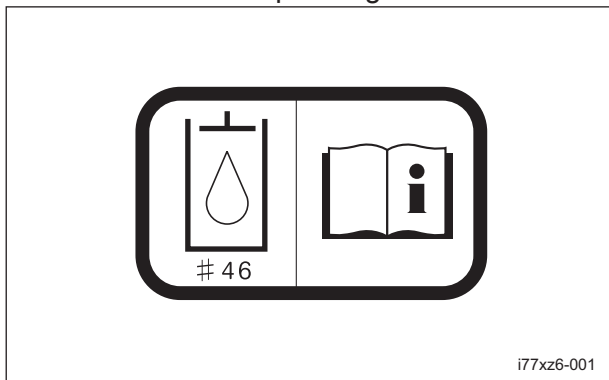

Hydraulic Oil Icon\_001

## Diesel Fuel Icon

K4209001000  
Diesel fuel icon  
Use diesel fuel.

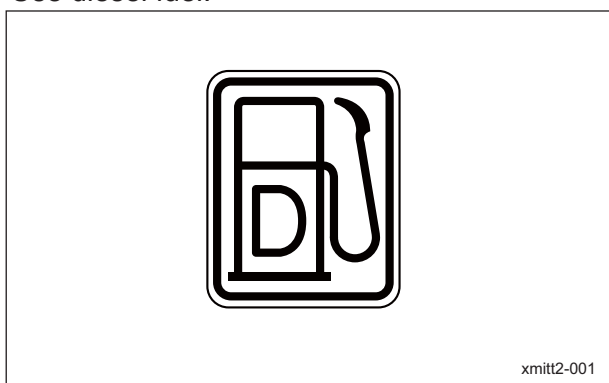

Diesel Fuel Icon\_001

## Fire Prohibited Decal

K4205001940  
Decal, fire prohibited

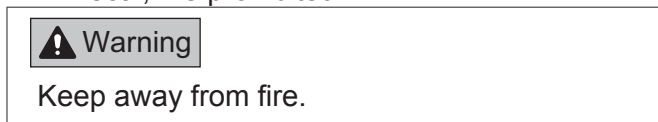

Fire Prohibited Decal\_001

## Caution for Mower Lock Decal

K4205001900  
Decal, caution for mower lock  
Lock the mower decks when traveling or storing with the mower decks #4 and 5 raised.



Caution for Mower Lock Decal\_001

### Caution for Spouting Coolant Decal

K4205001970  
Decal, caution for spouting coolant

**Caution**

Caution for spouting coolant - Do not open while hot.  
High temperature - Do not touch. Otherwise, you will get burned.

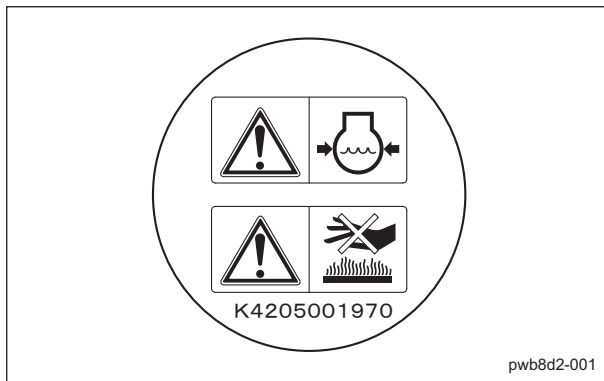

Caution for Spouting Coolant Decal\_001

### Caution to Flying Object Decal

K4205001650  
Decal, caution to flying object

**Caution**

Caution to flying object - Be sure that people around the machine keep a safe distance away.

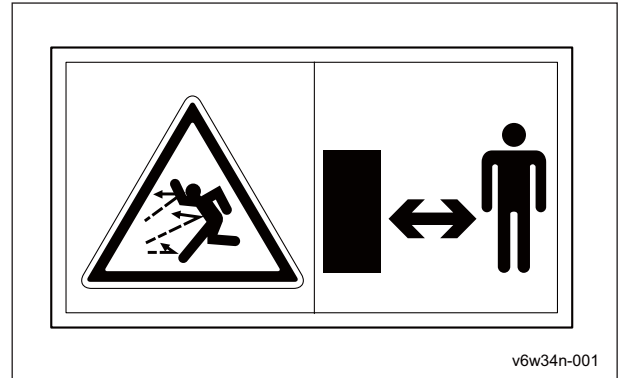

Caution to Flying Object Decal\_001

### Caution to Getting Pinched Decal

K4205001930  
Decal, caution to getting pinched

**Caution**

May pinch - There is a risk of being pinched.

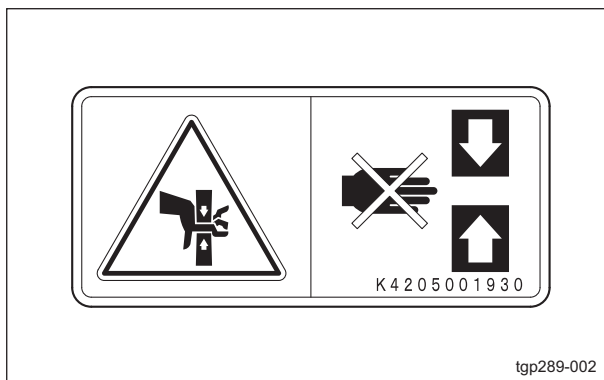

Caution to Getting Pinched Decal\_001

### Caution for Hand or Leg Injury Decal

K4205001780  
Decal, caution for hand or leg injury

**Warning**

May cut your hand or leg - When the blades are rotating, keep away from the machine.

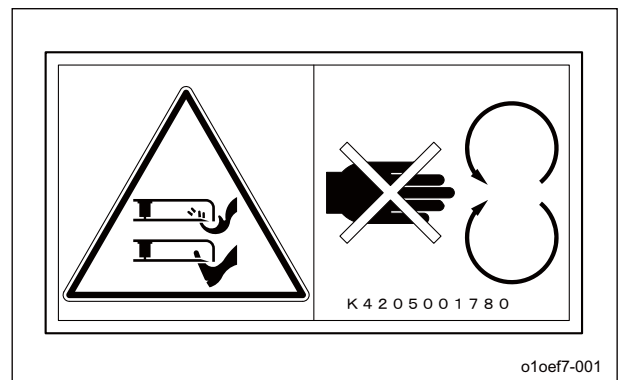

Caution for Hand or Leg Injury Decal\_001

# Product Overview

## Caution Exhaust Gas Decal

K4205001950

Decal, caution exhaust gas

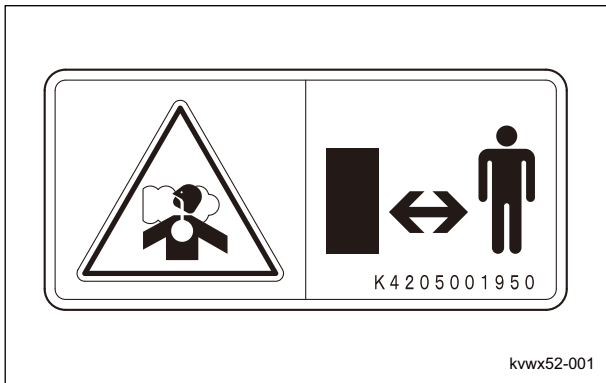
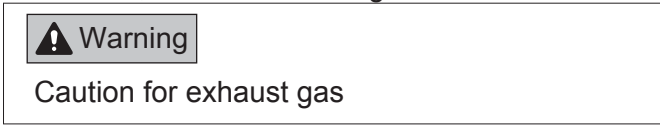

Caution Exhaust Gas Decal\_001

## Engine Warning Lamp Decal

K4205002270

Decal, Engine Warning Lamp

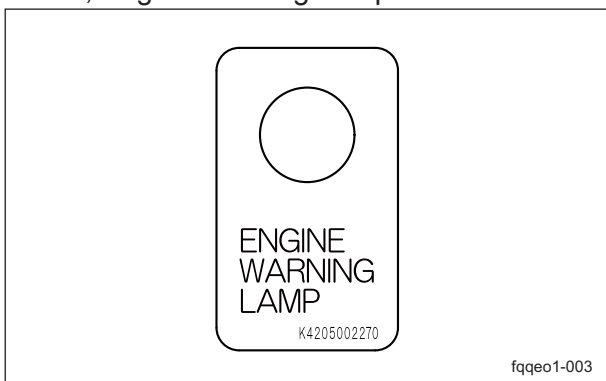

Engine Warning Lamp Decal\_001

## Caution to Noise Decal

K4205002090

Decal, caution to noise

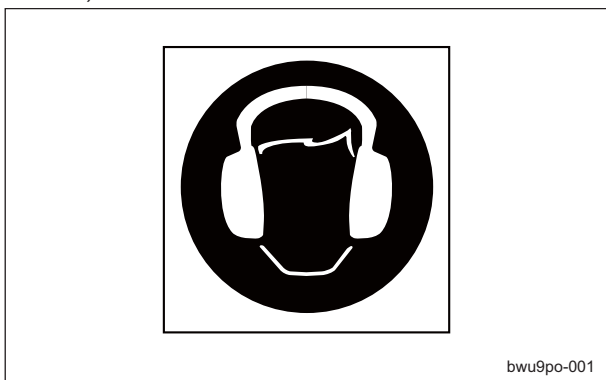

Caution to Noise Decal\_001

## Maintenance Decal

K4209001940

Maintenance decal

The maintenance decal indicates the necessary inspection and maintenance items for this machine.

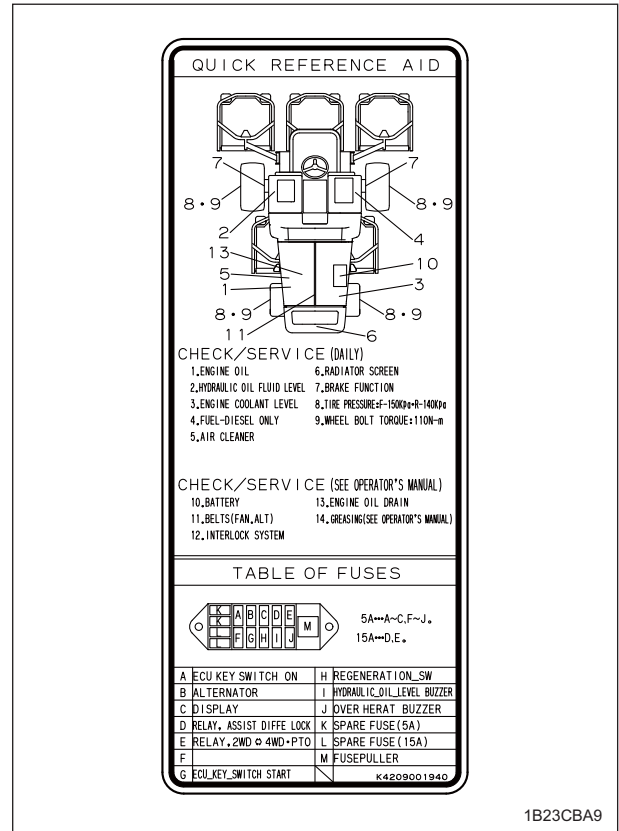

Maintenance Decal\_001

## 2WD/4WD Selector Important Decal

K4205002330

DECAL, IMPORTANT 2WD/4WD SELECTOR

**Important**

Be sure to operate the 2WD/4WD selector switch when the machine stops.  
Otherwise, the hydraulic system will malfunction.

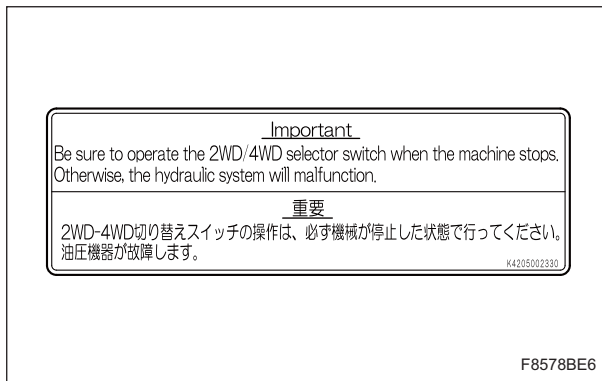

2WD/4WD Selector Important Decal\_001

## Knife Rotation Important Decal

K4205002340

DECAL, IMPORTANT KNIFE ROTATION

**Important**

Be sure to operate the knife rotation switch when the machine stops.  
Otherwise, the hydraulic system will malfunction.

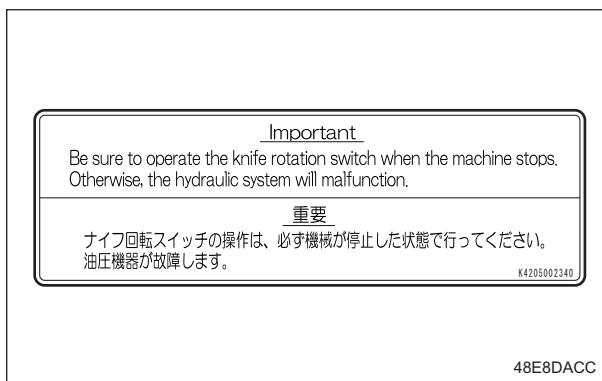

Knife Rotation Important Decal\_001

# Product Overview

---



# Handling Instructions

<b>Inspections</b> .....	<b>Page 4-2</b>	Proximity Sensors .....	Page 4-28
Rotary Knife .....	Page 4-2	Relays .....	Page 4-28
Radiator Cover .....	Page 4-2	Knife Rotation Switch .....	Page 4-29
Radiator .....	Page 4-3	2WD/4WD Selector Switch .....	Page 4-29
Coolant .....	Page 4-3	DPF Auto Regeneration Inhibit Switch .....	Page 4-30
Oil Cooler .....	Page 4-4	DPF Parked Regeneration Switch .....	Page 4-31
Hydraulic Oil .....	Page 4-5	Light Switch .....	Page 4-31
Hydraulic Hoses .....	Page 4-6	Traction Assist Switch .....	Page 4-32
Air Cleaner .....	Page 4-6	Mower Lock Lever (Latch) .....	Page 4-32
Battery .....	Page 4-7	Mower Deck Up/Down Lever .....	Page 4-32
Electrical Wiring .....	Page 4-8	Throttle Knob .....	Page 4-33
Tire .....	Page 4-8	Diff-Lock Switch .....	Page 4-33
Brake .....	Page 4-8	Traveling Pedal .....	Page 4-33
Belt .....	Page 4-9	Brake Pedal .....	Page 4-34
Wire .....	Page 4-9	Parking Brake Lever .....	Page 4-35
Safety Device .....	Page 4-9	Hood .....	Page 4-35
Around The Engine .....	Page 4-9	Underseat Cover .....	Page 4-36
Engine Oil .....	Page 4-9	<b>Instruments</b> .....	<b>Page 4-36</b>
Fuel .....	Page 4-10	Description of Monitor .....	Page 4-36
Water Separator .....	Page 4-11	Displayed Icon .....	Page 4-37
Fuel Filter .....	Page 4-13	Main Menu Items .....	Page 4-37
Oil Leakage .....	Page 4-13	Engine Warning Lamp .....	Page 4-71
<b>Tightening Torques</b> .....	<b>Page 4-14</b>	<b>Move</b> .....	<b>Page 4-72</b>
Standard Tightening Torques .....	Page 4-14	Traveling Procedure .....	Page 4-72
Principal Tightening Torques .....	Page 4-17	Towing The Machine .....	Page 4-72
<b>Adjustment before Work</b> .....	<b>Page 4-19</b>	<b>Cutting Work</b> .....	<b>Page 4-73</b>
Adjustment of Steering Wheel .....	Page 4-19	Cutting Operation .....	Page 4-73
Adjustment of Seat .....	Page 4-19	<b>Transporting</b> .....	<b>Page 4-74</b>
Adjustment of Cutting Height .....	Page 4-19	Transporting Procedure .....	Page 4-74
<b>Procedure to Start/Stop Engine</b> .....	<b>Page 4-22</b>	<b>Storage</b> .....	<b>Page 4-74</b>
Start/Stop of Engine .....	Page 4-22	Before Long-Term Storage .....	Page 4-74
Safety Mechanisms .....	Page 4-23		
Warning Mechanisms .....	Page 4-23		
<b>Operation Method</b> .....	<b>Page 4-24</b>		
Cautions for when You Leave The Machine .....	Page 4-24		
Positions of Operation Decals .....	Page 4-24		
Description of Operation Decals .....	Page 4-24		

# Handling Instructions

## Inspections

Inspect the machine according to the maintenance schedule so that you will be able to take advantage of its optimum performance for a long period of time.

### Rotary Knife

#### Inspection of Rotary Knife

##### Caution

When touching edged tools, wear gloves, since they could cut your hands.

Due to frequent use, objects crushed during mowing, or damage during transportation and so forth, the rotary knife may vibrate from imbalance or become dull. Inspect the rotary knife, and if necessary, sharpen, balance or replace it.

##### Important

Frequently inspect the rotary knife since it may become dull quickly if the machine is operated in an environment of dry soil or sand.

1. Make sure that the rotary knife is not bent.
2. Make sure that the rotary knife is not chipped.
3. Check to see how much the rotary knife is worn.
4. Make sure that the rotary knife is not worn asymmetrically.
5. Make sure that the mounting bolt for the rotary knife is not loose.
6. Make sure that there are no cracks or tears between the sail and flat part of the rotary knife.

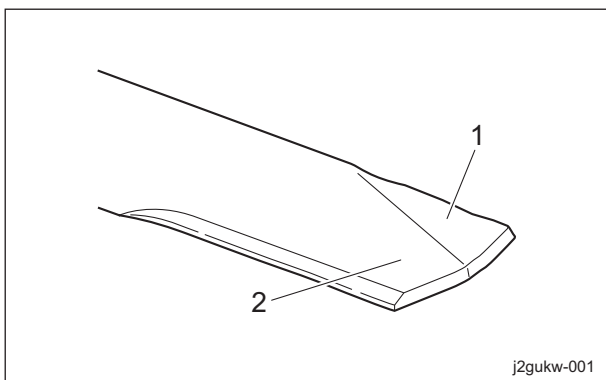

Inspection of Rotary Knife\_001

1	Sail
2	Flat part

### Radiator Cover

#### Inspection of Radiator Cover

1. Make sure that there is no damage to the radiator cover.
2. Make sure that the radiator cover is not contaminated.

#### Cleaning of Radiator Cover

##### Important

An unclean radiator cover may cause overheating or damage to the engine. It may also cause malfunction of the hydraulic system.

If the radiator cover has been contaminated with dust, be sure to clean it. After operating the machine in a dusty environment, it is important to remove dust from the cover as soon as possible.

1. Open the radiator cover.

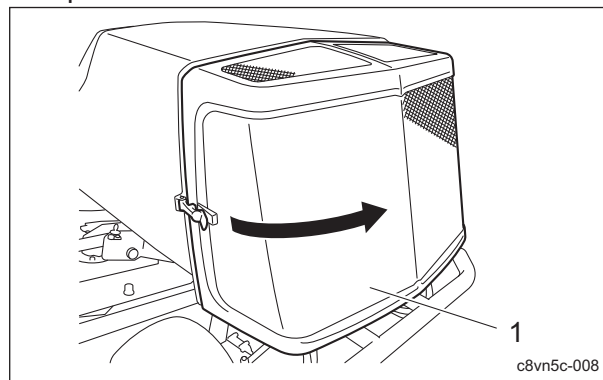

Cleaning of Radiator Cover\_001

1	Radiator cover
---	----------------

2. Carefully clean the front and back of the radiator cover with water or compressed air.

# Handling Instructions

## Radiator

### Inspection of Radiator

1. Make sure that there is no damage to the radiator.
2. Make sure that the radiator is not contaminated.

### Cleaning of Radiator

**Important**

An unclean radiator may cause overheating or damage to the engine. It may also cause malfunction of the hydraulic system.

**Important**

Do not use solid objects, such as a spatula or screwdriver, or high-pressure water to clean the radiator or oil cooler. Otherwise, special fins or tubes may be damaged, possibly resulting in reduced cooling performance or coolant leakage.

If the radiator has been contaminated with dust, be sure to clean it. After operating the machine in a dusty environment, it is important to remove dust as soon as possible.

1. Open the radiator cover.
2. Unlock the rubber catches on the left and right of the oil cooler, and then tilt the oil cooler.

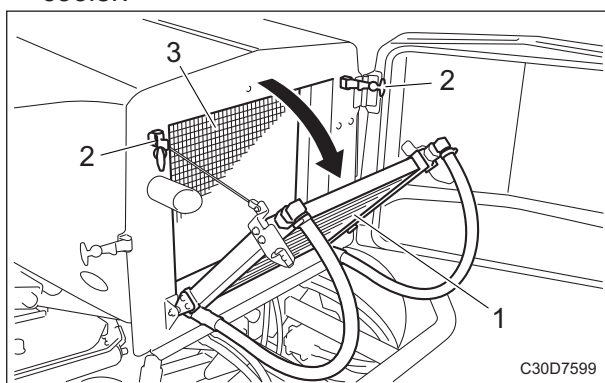

Cleaning of Radiator\_001

1	Oil cooler
2	Rubber catch
3	Radiator

3. Carefully clean the front and back of the radiator with water or compressed air.

## Coolant

### Inspection of Coolant

**Caution**

Do not touch the radiator or coolant during engine operation or immediately after the engine has been turned off. Otherwise, you may get burned.

**Caution**

Inspection should take place after the engine has well cooled down.

1. Make sure that the coolant level in the reserve tank is between "FULL" and "LOW".

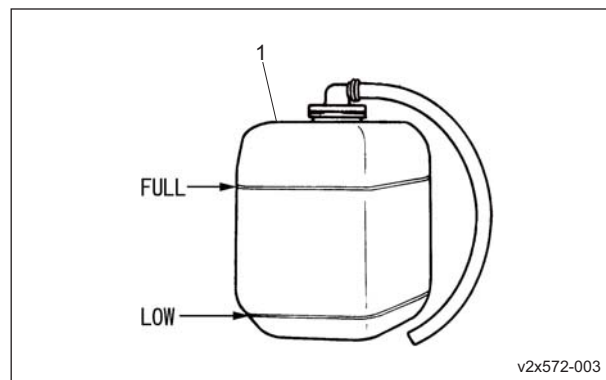

Inspection of Coolant\_001

1	Reserve tank
---	--------------

# Handling Instructions

## Coolant Supply

1	Reserve tank
---	--------------

### ⚠ Caution

Do not touch the radiator or coolant during engine operation or right after the engine has been turned off. Due to high temperatures, doing so could cause burns.

### ⚠ Caution

Supply coolant after the engine has well cooled down.

### ⚠ Caution

The radiator cap is pressurized. If you remove the radiator cap while the engine is overheated, hot steam will burst out, possibly resulting in burns. Make sure that the water temperature and pressure are reduced, and then grab the cap with a thick cloth and gradually open the cap.

### Important

When you supply coolant, be sure to use clean water, such as tap water.

### Important

Tightly close the radiator cap. If the cap is loose or incorrectly installed, the engine will be overheated due to water leakage, resulting in engine damage.

1. If the coolant level in the reserve tank is lower than the "LOW" mark, open the reserve tank cap and fill the tank with clean water up to the "FULL" mark.

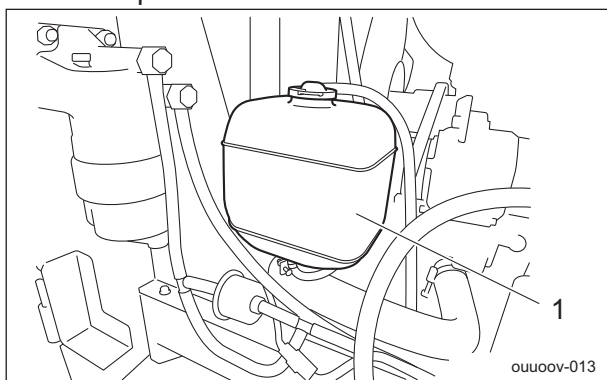

Coolant Supply\_001

2. If no coolant is in the reserve tank, follow the steps below to fill the tank with clean water.

- [1] Open the radiator cap, and then supply clean water up to the opening.
- [2] Open the reserve tank cap, and then supply clean water up to the "FULL" mark.

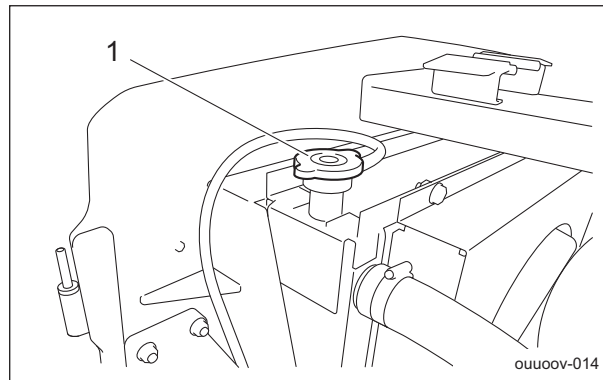

Coolant Supply\_002

1	Radiator cap
---	--------------

## Oil Cooler

### Inspection of Oil Cooler

1. Make sure that there is no damage to the oil cooler.
2. Make sure that the oil cooler is not contaminated.

### Cleaning of Oil Cooler

#### Important

An unclean oil cooler may cause malfunction of the hydraulic system.

#### Important

Do not use solid objects, such as a spatula or screwdriver, or high-pressure water to clean the radiator or oil cooler. Otherwise, special fins or tubes may be damaged, possibly resulting in reduced cooling performance or coolant leakage.

If the oil cooler has been contaminated with dust, be sure to clean it. After operating the machine in a dusty environment, it is important to remove dust as soon as possible.

1. Open the radiator cover.

# Handling Instructions

- Unlock the rubber catches on the left and right of the oil cooler, and then tilt the oil cooler.

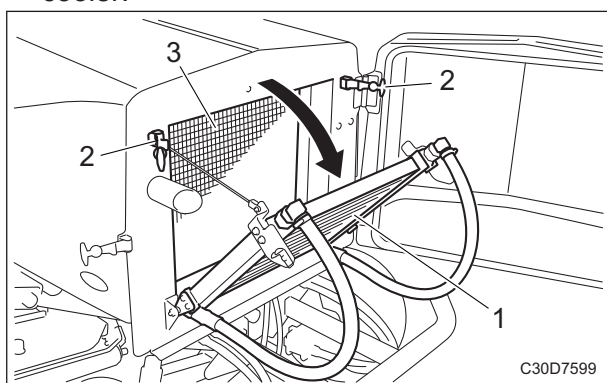

Cleaning of Oil Cooler\_001

1	Oil cooler
2	Rubber catch
3	Radiator

- Carefully clean the front and back of the oil cooler with water or compressed air.

## Hydraulic Oil

### Inspection of Hydraulic Oil

The oil gauge is on the side of the hydraulic tank.

- Raise the mower decks and maintain that position on a level surface.
- Make sure that the oil level is at the middle of the oil gauge.

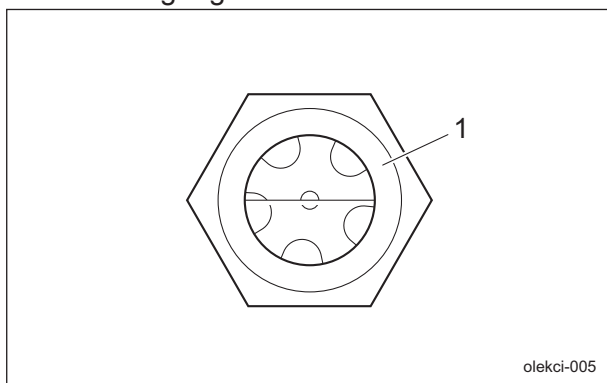

Inspection of Hydraulic Oil\_001

1	Oil gauge
---	-----------

- Check underneath the machine for oil leakage.

### Hydraulic Oil Supply

**Important**

Do not mix different types of oil.

**Important**

Use Shell Tellus S2M46 (or equivalent) as hydraulic oil. In case of an equivalent, consult Characteristics of Hydraulic Oil and use hydraulic oil whose characteristics are superior to those of the specific hydraulic oil. Especially regarding kinematic viscosity and viscosity index, use of hydraulic oil whose figures are less than those of the specified hydraulic oil will cause a malfunction in the hydraulic circuit.

**Note:**

### Characteristics of Hydraulic Oil

Specified Hydraulic Oil		Shell Tellus S2M46
ISO Viscosity Grade		ISO VG46
Density	15 °C (59 °F)	0.873 g/cm <sup>3</sup> (0.0315 lb/in <sup>3</sup> )
API Gravity		30.6
Flash Point (Open Cup)		230 °C (446 °F)
Pour Point		-30 °C (-22 °F)
Kinematic	40 °C (104 °F)	46 mm <sup>2</sup> /s (46 cSt)
Viscosity	100 °C (212 °F)	7 mm <sup>2</sup> /s (7 cSt)
Viscosity Index		109

- If the oil level is low, remove the left tank cover, and then open the tank cap and supply oil.

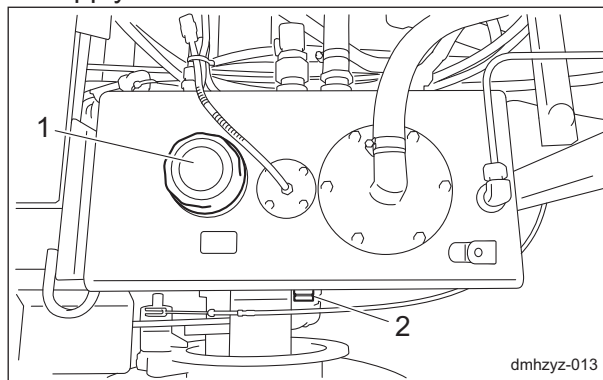

Hydraulic Oil Supply\_001

1	Tank cap
2	Oil gauge

- Tighten the tank cap securely.

# Handling Instructions

3. Start the engine, raise and lower the mower decks, and turn the steering wheel left and right.

Move forward and reverse repeatedly several times.

4. Raise the mower decks and maintain that position on a level surface, and then check to see if the oil level is at the middle of the oil gauge. If necessary, supply oil.
5. Check underneath the machine for oil leakage.
6. Attach the left tank cover.

## Hydraulic Hoses

### Inspection of Hydraulic Hoses

#### Warning

When checking the hydraulic circuit for pinhole leaks or oil leakage from nozzles, do not use your hands. Use items such as paper or corrugated cardboard to find leakage points.

Be extremely careful with high-pressure oil as it may pierce your skin, resulting in personal accidents.

If fluid is injected into the skin it must be surgically removed within a few hours by a doctor familiar with this form of injury or gangrene may result.

Check the pipes and hoses to make sure that there is no oil leakage, circuit damage, looseness, wear, connector looseness, weather deterioration and chemical deterioration.

Make any necessary repairs before operating the machine.

## Air Cleaner

### Inspection of Air Cleaner

Liners and piston rings so that the engine will always operate smoothly.

A contaminated air cleaner element may cause malfunction of the engine.

1. Inspect the air cleaner by checking the vacuum indicator.  
If the air cleaner element is contaminated, the vacuum indicator will display a red ring.

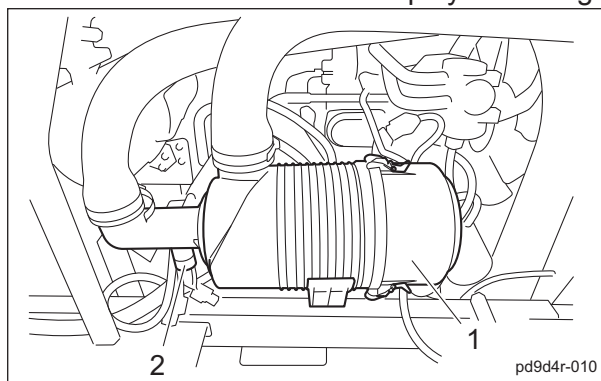

Inspection of Air Cleaner\_001

1	Air cleaner
2	Vacuum indicator

2. Make sure that there is no damage to the air cleaner.
3. Make sure that the air cleaner is not contaminated.

### Cleaning of Air Cleaner

A contaminated air cleaner element may cause malfunction of the engine.

To maximize the life of the engine, clean the air cleaner properly.

#### Important

The inner element cannot be cleaned.

1. Follow the steps below to clean the outer element.
  - [1] Remove the clips from the three locations, remove the air cleaner cap, and then remove the outer element.
  - [2] While paying close attention not to damage the outer element, tap a solid portion of the outer element or blow compressed air from its inside to remove dust and dirt.  
If the outer element is extremely contaminated, replace it with a new one.



# Handling Instructions

[3] Attach the outer element to the air cleaner body.

[4] Replace the air cleaner cap, and then fix it securely using the clips.

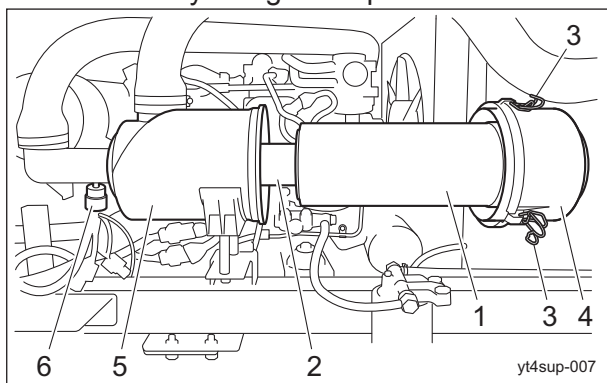

Cleaning of Air Cleaner\_001

1	Outer element
2	Inner element
3	Clip
4	Air cleaner cap
5	Air cleaner body
6	Vacuum indicator

2. Press the reset button for the vacuum indicator.

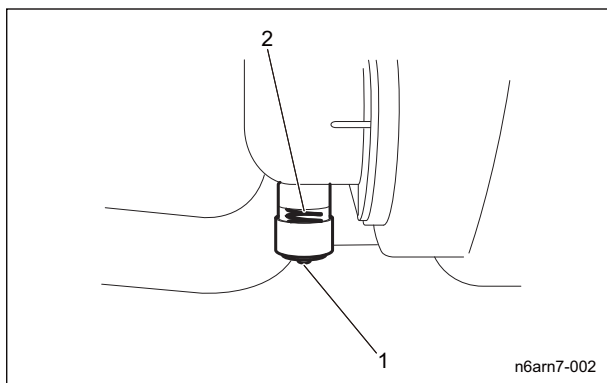

Cleaning of Air Cleaner\_002

1	Reset button
2	Vacuum indicator

## Battery

### Inspection of Battery

#### **Danger**

Keep away from fire while inspecting or charging the battery.  
The battery may explode.

#### **Warning**

Do not allow the battery fluid level to become lower than the LOWER LEVEL (minimum fluid level line).  
The battery may explode if it is used or charged while the battery fluid level is at the LOWER LEVEL (minimum fluid level line).

#### **Caution**

Perform operations after the muffler and engine have sufficiently cooled.  
Otherwise, you may suffer burns.

1. Clean the areas around the battery fluid level lines using a cloth damped with water.
2. Make sure that the battery fluid level is between the UPPER LEVEL (maximum fluid level line) and the LOWER LEVEL (minimum fluid level line).

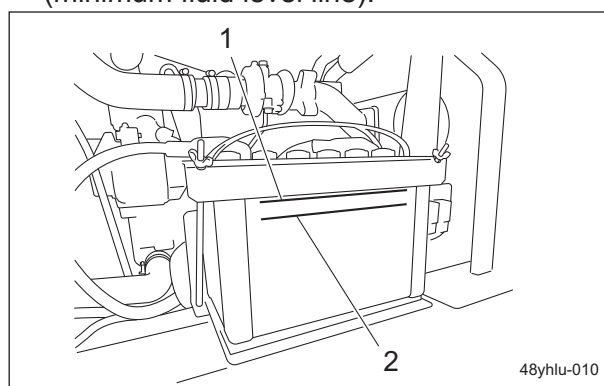

Inspection of Battery\_001

1	UPPER LEVEL
2	LOWER LEVEL

# Handling Instructions

## Supply of Battery Fluid

### **Danger**

Be careful not to let your skin, eyes or clothes, etc., come into contact with the battery fluid or accidentally swallow the fluid. Should your skin or clothes come into contact with the battery fluid, immediately wash them away with water.

### **Danger**

When you supply battery fluid, wear protective garments and safety glasses, etc.

### **Caution**

Implement after the engine and muffler etc. have well cooled down. Otherwise you may get burned.

1. If the battery fluid level is lower than halfway between the UPPER LEVEL (maximum) line and LOWER LEVEL (minimum) line, add purified water up to the UPPER LEVEL (maximum) line.

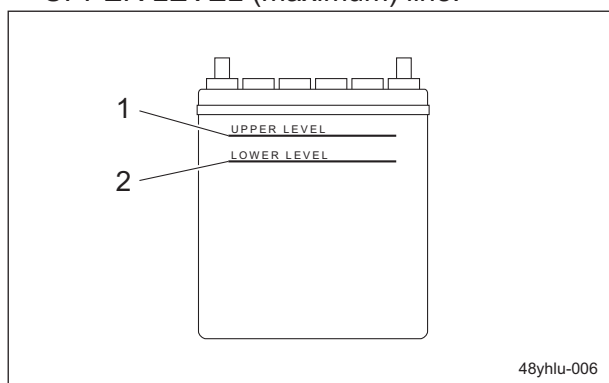

Supply of Battery Fluid\_001

1	UPPER LEVEL
2	LOWER LEVEL

## Electrical Wiring

### Inspection of Electrical Wiring

#### Important

Electrical short circuit will cause fire, electrical leakage and malfunction of electrical equipments.

Inspect electrical wiring for poor terminal connections, damaged wiring or terminals, loose connections, weather-related deterioration and chemical-related deterioration.

If necessary, repair before operating the machine.

## Tire

### Inspection of Tires

1. Check the pneumatic pressure of the tires.
2. Make sure that there are no cracks, damage or abnormal wear.

Tire size	Pneumatic pressure
Front wheel (29 x 14.00 - 15)	150 kPa (1.5 kgf/cm <sup>2</sup> )
Rear wheel (20 x 12.00 - 10)	140 kPa (1.4 kgf/cm <sup>2</sup> )

## Brake

### Inspection of Brake Pedal

1. When depressing the brake pedal fully, make sure that there is appropriate clearance between the floorboard and the pedal or pedal reserve distance.
2. When depressing the brake pedal fully, make sure that the pedal reaction is not spongy and that there is no noise.
3. When depressing the brake pedal during traveling, make sure that the machine stops smoothly and the braking is sufficiently effective.

### Inspection of Parking Brake

1. Make sure that the parking brake is applied after depressing the brake pedal and pulling the parking brake lever.
2. Make sure that the parking brake is not applied even slightly after depressing the brake pedal to release the parking brake lever.



# Handling Instructions

## Belt

### Inspection of Belt

#### Warning

The engine must be stopped when the belt is inspected.

#### Important

A slacking or damaged belt or damaged fan may cause overheating or lack of a battery charge.

1. Press the middle of the belt with your finger to check the belt tension.
2. Make sure that there are no cracks, damage or abnormal wear.

## Wire

### Inspection of Wire

1. Make sure that the wire is not cracked or damaged.
2. If the wire is cracked or damaged, replace it with a new one immediately.

## Safety Device

### Inspection of Safety Device

Make sure that the safety device operates correctly.

"Safety Mechanisms" (Page 4-23)

## Around The Engine

### Inspection of Engine-Associated Parts

#### Caution

Implement after the engine and DPF etc. have well cooled down.  
Otherwise you may get burned.

1. Check the fuel system parts for loosened or cracked joints and leakage. Replace the parts if necessary.
2. Blow compressed air to clean any grass or flammable materials that may be attached on or around the DPF.  
Remove clippings and dust in a gap thoroughly due to the intricately shaped engine.

## Engine Oil

### Inspection of Engine Oil

#### Important

Securely tighten the oil level gauge and oil filler cap.

1. Stop the engine, wait for 10 to 20 minutes for the engine to cool down, and then check the oil level.
2. Position the machine so that the engine will be level, and then insert the oil level gauge all the way to check the oil level.

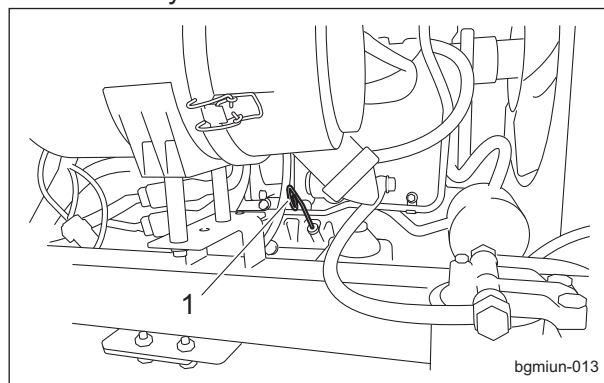

Inspection of Engine Oil\_001

1	Oil gauge
---	-----------

3. The appropriate oil level should be between the upper and lower limit lines on the gauge.

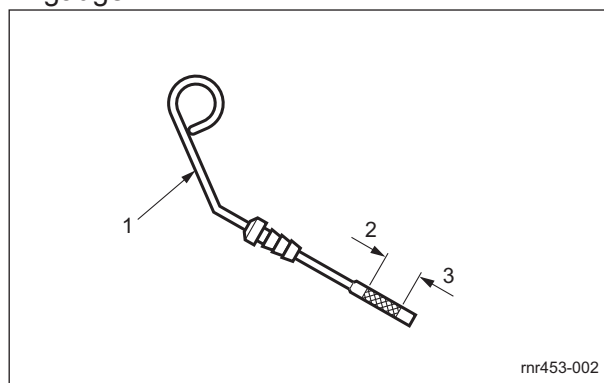

Inspection of Engine Oil\_002

1	Oil level gauge
2	Upper limit
3	Lower limit

# Handling Instructions

## Supply of Engine Oil

**Important**

Do not supply too much engine oil. Otherwise, the engine may be damaged.

**Important**

Do not mix different types of engine oil.

**Important**

Be sure to use engine oil that is classified as JASO DH-2 or API Service Grade CJ-4, with SAE viscosity that is appropriate for the operating environment (ambient temperature).

**Important**

Securely tighten the oil level gauge and oil filler cap.

1. If the engine oil level is lower than the lower limit line on the oil level gauge, supply engine oil through the oil filling port. Remove the oil filler cap, and then supply new engine oil until the oil reaches a level in between the upper and lower limit lines on the oil level gauge.
2. Replace the oil filler cap.

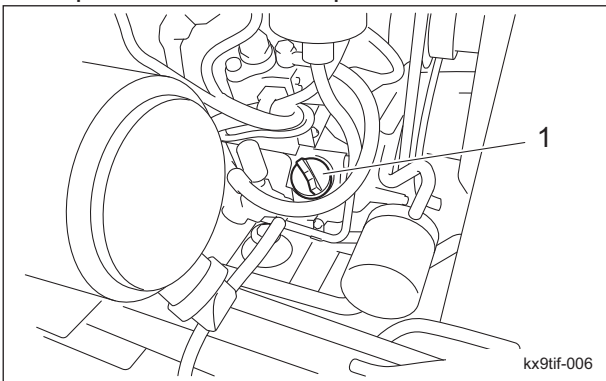

Supply of Engine Oil\_001

1	Oil filler cap
---	----------------

3. It will take a while for the supplied engine oil to descend into the oil pan. Check the oil level again 10 to 20 minutes after supplying the oil.

## Fuel

### Inspection of Fuel Quantity

With the machine on a level surface, observe the fuel level in the monitor to check the fuel level.

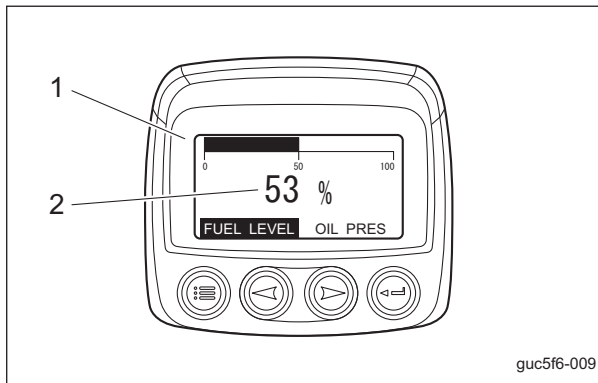

guc5f6-009

Inspection of Fuel Quantity\_001

1	Monitor
2	Fuel level

# Handling Instructions

## Fuel Supply

**Warning**

Do not supply additional fuel after the fuel level indicates 100%.  
If you supply too much fuel, it might overflow from the fuel cap when you travel or work on a slope.

**Warning**

Keep fire away while refueling.  
Do not smoke.

**Important**

Use ultra-low sulfur diesel fuel (sulfur-free diesel fuel).

**Important**

In case of lack of fuel, DPF regeneration can not be performed.

If the monitor displays the warning message "FUEL LEVEL LOW", immediately stop operation, and then supply fuel (diesel). The fuel tank capacity is approximately 51.0 dm<sup>3</sup> (51.0 L).

Note:

The factory default low fuel level is 10%. The level can be changed optionally.

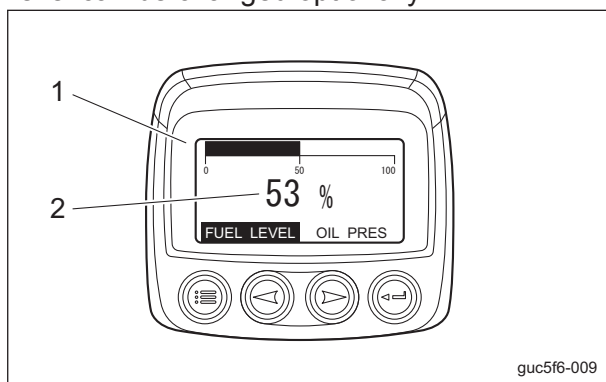

Fuel Supply\_001

1	Monitor
2	Fuel level

## Air Bleeding of Fuel System

1. Open the hood.
2. Set the key switch to the "ON" position and then start the electromagnetic pump.

3. A priming pump is installed on the feed pump.  
Repeatedly press the top of the priming pump with your finger until resistance is felt, to bleed air.
4. Set the key switch to the "OFF" position.
5. Close the hood.

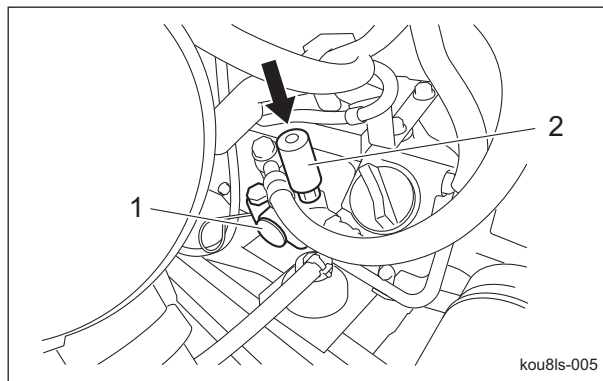

Air Bleeding of Fuel System\_001

1	Feed pump
2	Priming pump

## Water Separator

### Inspection of Water Separator

**Important**

If water contaminates the fuel, the supply pump and injector will seize due to heat.

The water separator removes water from the fuel.

1. Make sure that debris and water have not accumulated in the cup.  
With the float raised, water incorporation is confirmed.

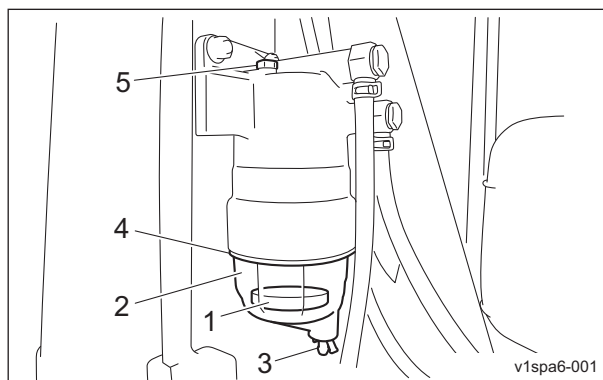

Inspection of Water Separator\_001

# Handling Instructions

1	Float
2	Cup
3	Water drain plug
4	Element
5	Air-bleeding bolt

## Draining of Water Separator

**Important**

If water contaminates the fuel, the supply pump and injector will seize due to heat.

Drain the water in accordance with the Maintenance Schedule. However, when the float is raised by water, drain the water even before the schedule.

1. Follow the steps below to drain the water.
  - [1] Stop the engine, and then turn the key switch to the "OFF" position.
  - [2] Place a container under the water separator.
  - [3] Loosen the water drain plug and air-bleeding bolt to drain the water into the container.

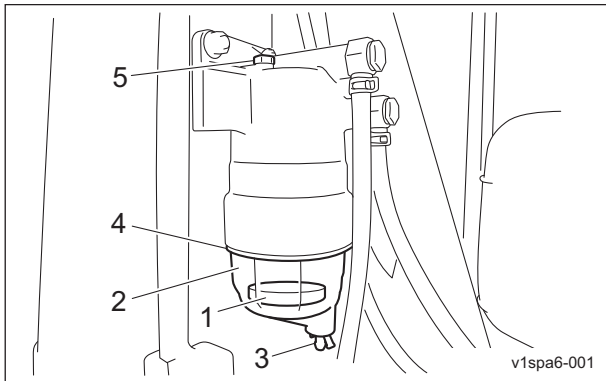

Draining of Water Separator\_001

1	Float
2	Cup
3	Water drain plug
4	Element
5	Air-bleeding bolt

- [4] Tighten the water drain plug and air-bleeding bolt.
- [5] Bleed air from the fuel system.

## Cleaning of Water Separator

**Important**

If water contaminates the fuel, the supply pump and injector will seize due to heat.

Clean the water separator in accordance with the Maintenance Schedule. However, when debris has accumulated in the cup, clean it even before the schedule.

1. Follow the steps below to clean the water separator.
  - [1] Stop the engine, and then turn the key switch to the "OFF" position.
  - [2] Place a container under the water separator.
  - [3] Remove and clean the cup, element and float. Replace the element with a new one when replacement needed.

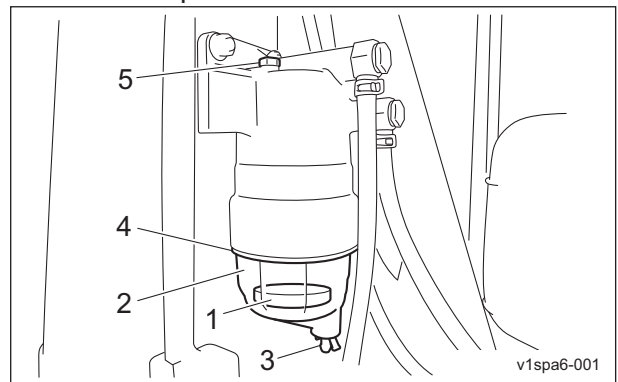

Cleaning of Water Separator\_001

1	Float
2	Cup
3	Water drain plug
4	Element
5	Air-bleeding bolt

- [4] Install the cup, element and float in their original positions.
- [5] Bleed air from the fuel system.

## Fuel Filter

### Inspection of Fuel Filter

The fuel filter works to remove foreign objects mixed into the fuel.

When the fuel flow becomes insufficient, replace the fuel filter if necessary.

1. Make sure that there is no fuel leakage.
2. Make sure that the fuel filter is not damaged or dirty.

## Oil Leakage

### Inspection of Oil Leakage

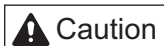

When performing maintenance on the hydraulic system, lower the mower decks.

After approximately 50 hours of operation, some tightened portions may be loosened and oil and grease may leak.

Be sure to retighten the parts.

Check the bottom of the machine for oil and grease leakage.

# Handling Instructions

---

## Tightening Torques

### Important

Refer to the Tightening Torque table.  
Note that the Baroness product warranty may not apply to defects caused by incorrect or overtorque tightening, etc.

## Standard Tightening Torques

### Bolts and Nuts

### Important

A number of bolts are used in each part of this machine.  
Be sure to re-tighten the bolts and nuts, because they may be loosened at the earlier stage of the use.

As to the bolts and nuts without any special instruction, tighten them in appropriate tightening torque with proper tool.

Too much tightening may cause the looseness or damage of the screw.

The strength of tightening is determined by types of screws, strength, the friction of thread face or base face and others.

The table below is for the galvanized or parkerized bolts.

In case that the strength of internal thread is weak, it is not applied.

Do not use rusty or sand attached "screw."

Otherwise, it may cause insufficient tightening even if you apply the specified tightening torque.

The friction of the screw face becomes higher and the tightening torque is canceled out by the friction, therefore sufficient tightening cannot be applied.

If "screw" is wet by water or oil, do not tighten it with normal tightening torque.

If the screw is wet, the torque coefficient will get smaller and it may result in too much tightening.

Too much tightening may cause looseness by the screw stretched or result in damage.



Do not use a bolt experienced too much burden.

Using the impact wrench requires the skill.

Do exercise as much as possible for steady tightening.

# Handling Instructions

Nominal diameter	General bolt		
	Strength classification 4.8		
	 tib3yb-001		
	N-m	kgf-cm	lb-in
M5	3 - 5	30.59 - 50.99	26.55 - 44.26
M6	7 - 9	71.38 - 91.77	61.96 - 79.66
M8	14 - 19	142.76 - 193.74	123.91 - 168.17
M10	29 - 38	295.71 - 387.49	256.68 - 336.34
M12	52 - 67	530.24 - 683.20	460.25 - 593.02
M14	70 - 94	713.79 - 958.52	619.57 - 831.99
M16	88 - 112	897.34 - 1142.06	778.89 - 991.31
M18	116 - 144	1,182.85 - 1,468.37	1,026.72 - 1,274.54
M20	147 - 183	1,498.96 - 1,866.05	1,301.10 - 1,619.73
M22	295	3,008.12	2,611.05
M24	370	3,772.89	3,274.87
M27	550	5,608.35	4,868.05
M30	740	7,545.78	6,549.74

Nominal diameter	Heat-treated bolt					
	Strength classification 8.8			Strength classification 10.9		
	 tib3yb-002			 tib3yb-003		
	N-m	kgf-cm	lb-in	N-m	kgf-cm	lb-in
M5	5 - 7	50.99 - 71.38	44.26 - 61.96	7 - 10	71.38 - 101.97	61.96 - 88.51
M6	8 - 11	81.58 - 112.17	70.81 - 97.36	14 - 18	142.76 - 183.55	123.91 - 159.32
M8	23 - 29	234.53 - 295.71	203.57 - 256.68	28 - 38	285.52 - 387.49	247.83 - 336.34
M10	45 - 57	458.87 - 581.23	398.30 - 504.51	58 - 76	591.43 - 774.97	513.36 - 672.68
M12	67 - 85	683.20 - 866.75	593.02 - 752.34	104 - 134	1,060.49 - 1,366.40	920.50 - 1186.03
M14	106 - 134	1,080.88 - 1,366.40	938.21 - 1,186.03	140 - 188	1,427.58 - 1,917.04	1,239.14 - 1,663.99
M16	152 - 188	1,549.94 - 1,917.04	1,345.35 - 1,663.99	210 - 260	2,141.37 - 2,651.22	1,858.71 - 2,301.26
M18	200 - 240	2,039.40 - 2,447.28	1,770.20 - 2,124.24	280 - 340	2,855.16 - 3,466.98	2,478.28 - 3,009.34
M20	245 - 295	2,498.27 - 3,008.12	2,168.50 - 2,611.05	370 - 450	3,772.89 - 4,588.65	3,274.87 - 3,982.95
M22	-	-	-	530	5,404.41	4,691.03
M24	-	-	-	670	6,831.99	5,930.17
M27	-	-	-	1,000	10,197.00	8,851.00
M30	-	-	-	1,340	14,628.78	11,860.34

**Note:**

The same values are applied to "fine screw thread."

# Handling Instructions

---

## Hydraulic Hose

The tightening torques for union joints and union adaptors with parallel pipe threads (G, PF) are shown in the table below.

A union joint or adaptor will not become loose or leak as long as it is tightened by the specified torque.

If fluid leaks from the sealed portion, do not attempt to tighten the union joint or adaptor forcibly.

Examine whether any foreign matter or scratches are present on the seat surface.

Tightening a union joint or adaptor forcibly could damage the connection of the joints.

When tightening a union joint or adaptor, use a torque wrench where possible and firmly tighten it by an appropriate torque.

Nominal diameter of the hose size	Nominal diameter of the parallel pipe threads (PF)	Tightening torque		
		N-m	kgf-cm	lb-in
6	1/4	24.50	250	221.28
9	3/8	49.03	500	564.91
12	1/2	58.84	600	677.89
15	3/4	117.68	1200	1,355.78
19	3/4	117.68	1200	1,355.78
25	1	137.30	1400	1,581.74
32	1-1/4	166.72	1700	1,920.69
38	1-1/2	205.94	2100	2,372.61
50	2	245.17	2500	2,824.54

## Fittings with Parallel Threads (O-Ring Seal Type)

The tightening torques for fittings with parallel threads (O-ring seal method) are shown in the table below.

Tightening the fitting forcibly with a spanner or other such tool to secure it to a set position could damage the fitting, its washers, and other parts. Be sure to tighten the fitting to the torque appropriate to its size.

Nominal diameter of thread	Tightening torque		
	N-m	kgf-cm	lb-in.
1/4	34.32 - 49.03	350 - 500	309.79 - 442.55
3/8	68.65 - 78.45	700 - 800	619.57 - 708.08
1/2	98.07 - 117.68	1000 - 1200	885.10 - 1,062.12
3/4	147.10 - 176.52	1500 - 1800	1,327.65 - 1,593.18
1	245.17 - 274.59	2500 - 2800	2,212.75 - 2,478.28
1-1/4	294.20	3000	2,655.30
1-1/2	294.20	3000	2,655.30
2	392.27	4000	3,540.40



# Handling Instructions

## Principal Tightening Torques

### Tightening Torque by Model

GM2810A

Tighten the following bolts and nuts at the torque specified in the table.

For thread locking adhesive, apply a middle strength thread locker (ThreeBond 1322 or equivalent anaerobic sealant).

Location	Code	Part name	Tightening torque			Thread locking adhesive	
			N-m	kgf-cm	lb-in		
Front wheel	Motor housing	K0014160402	Bolt, heat-treated M16-40P1.5	152 - 188	1549.94 - 1917.04	1345.35 - 1663.99	—
	Motor	K0013140502	Bolt, heat-treated M14-50	100	1019.7	885.1	—
	Wheel mounting base	1 1/4-18UNF	Slotted nut (Hydraulic motor)	400 - 430	4078.80 - 4384.71	3540.40 - 3805.93	—
	Disc brake	K001A080401	Bolt, w/hexagon hole, M8-40	28 - 38	285.52 - 387.49	247.83 - 336.34	—
	Wheel	K0014120652	Bolt, heat-treated M12-65P1.5	110	1121.69	973.61	—
Rear wheel	Wheel mounting base	K0138240002	24 slotted nut high P1.5	180 - 200	1835.46 - 2039.40	1593.18 - 1770.20	—
	Wheel	K0014120652	Bolt, heat-treated M12-65P1.5	110	1121.69	973.61	—
Front axle	K0015200702	Bolt, heat-treated M20-70P1.5	370 - 450	3772.89 - 4588.65	3274.87 - 3982.95	—	
Brake ass'y	K1720000260 K1720000270	M12 nut (accessories)	50 - 70	509.85 - 713.79	442.55 - 619.57	○	
Engine	K0012120352	Bolt, heat-treated M12-35P1.25	67 - 85	683.20 - 866.75	593.02 - 752.34	—	
	K0015120552	Bolt, heat-treated M12-55P1.25	67 - 85	683.20 - 866.75	593.02 - 752.34	—	
	K0011100502	Bolt, heat-treated M10-50P1.25	58 - 76	591.43 - 774.97	513.36 - 672.68	—	
	K0013121102	Bolt, heat-treated M12-110	67 - 85	683.20 - 866.75	593.02 - 752.34	—	
	K3680000030	M3.5 Screw (accessories)	0.78 - 1.18	7.95 - 12.03	6.90 - 10.44	—	
Flywheel adapter	K0011100302	Bolt, heat-treated M10-30P1.25	58 - 76	591.43 - 774.97	513.36 - 672.68	—	
	K0010100352	Bolt, heat-treated M10-35	45 - 76	458.87 - 774.97	398.30 - 672.68	—	
Joint	K001A100401	Bolt, w/hexagon hole, M10-40	80	815.76	708.08	○	
	K0013100352	Bolt, heat-treated M10-35	45 - 76	458.87 - 774.97	398.30 - 672.68	—	
Kingpin stopper	K0010120502	Bolt, heat-treated M12-50	52 - 67	530.24 - 683.20	460.25 - 593.02	—	

# Handling Instructions

Location	Code	Part name	Tightening torque			Thread locking adhesive
			N-m	kgf-cm	lb-in	
Tie rod	K1610000020	Slotted nut of tie rod end RH	45	458.87	398.30	—
	K1611000020	Slotted nut of tie rod end LH	45	458.87	398.30	—
Piston pump	K0010120502	Bolt, heat-treated M12-50	67 - 134	683.20 - 1366.40	593.02 - 1186.03	—
Tandem gear pump	K0069000251	Bolt, 3/8-16 UNC 31.8	29 - 38	295.71 - 387.49	256.68 - 336.34	—
Pedal stopper	K0013101202	Bolt, heat-treated M10-120	29 - 38	295.71 - 387.49	256.68 - 336.34	—
Diff-lock valve	K001A100151	Bolt, w/hexagon hole, M10-15	29 - 38	295.71 - 387.49	256.68 - 336.34	—
Knife and knife guide	K0010120302	Bolt, heat-treated M12-30	67 - 85	683.20 - 866.75	593.02 - 752.34	—
Shoulder bolt	GM2800-0207Z2	Shoulder bolt	67 - 134	683.20 - 1366.40	593.02 - 1186.03	—
Bumper	K0010120302	Bolt, heat-treated M12-30	67 - 134	683.20 - 1366.40	593.02 - 1186.03	—
Cover mounting bracket	K0000080202	Bolt, M8-20	9 - 14	91.77 - 142.76	61.96 - 123.91	—
ROPS	K0013121102	Bolt, heat-treated M12-110	104 - 134	1060.49 - 1366.40	920.50 - 1186.03	—

# Handling Instructions

## Adjustment before Work

### Adjustment of Steering Wheel

#### Warning

Since it is dangerous, do not adjust the steering wheel while traveling.

#### Caution

Be sure the steering wheel position is securely locked. It may result in an unexpected accident if it becomes loose while traveling.

The steering wheel can be adjusted up or down.

Adjust the position according to the operator's body size.

Shift the tilt lever to the "FREE" position, move the steering wheel to the position that suits your work requirements, and then shift the tilt lever to the "LOCK" position to secure the steering wheel in place.

The tilt lever is located in the right front of the driver's position.

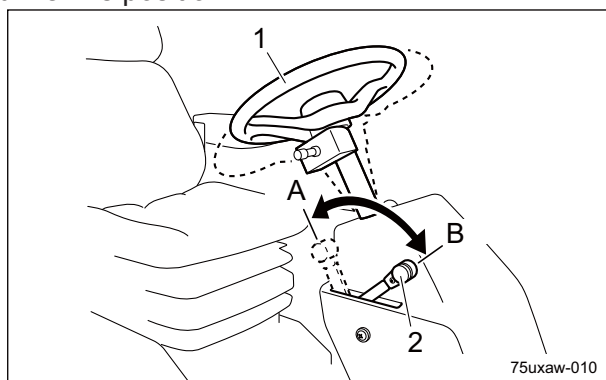

Adjustment of Steering Wheel\_001

1	Steering wheel
2	Tilt lever
A	FREE (released)
B	LOCK (locked)

### Adjustment of Seat

Use the adjustment levers to adjust the seat. Adjust the position to fit the operator.

1. Use the forward/backward adjustment lever to adjust the seat back and forth.
2. Use the tilt adjustment lever to adjust the angle of the backrest.

3. Turn the suspension adjustment handle to adjust the firmness of the seat suspension. Refer to the suspension indicator while making adjustments. [45 to 130 kg (99.2 to 286.6 lb)]
4. Turn the armrest adjustment knob to adjust the angle of the armrests.
5. Turn the seat height adjustment knob to adjust the height of the seat steplessly. [0 to 60 mm (0 to 2.36 in)]  
Adjust the height of the seat while sitting in it.

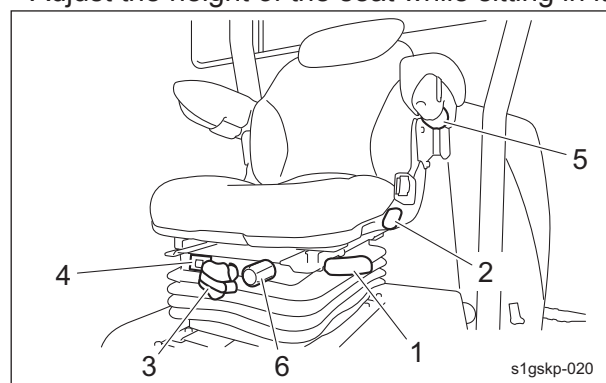

Adjustment of Seat\_001

1	Forward/backward adjustment lever
2	Tilt adjustment lever
3	Suspension adjustment handle
4	Suspension indicator
5	Armrest adjustment knob
6	Seat height adjustment knob

### Adjustment of Cutting Height

#### Cutting Height Table

The adjustment range for the cutting height is 20.0 - 91.5 mm (0.79 - 3.60 in).

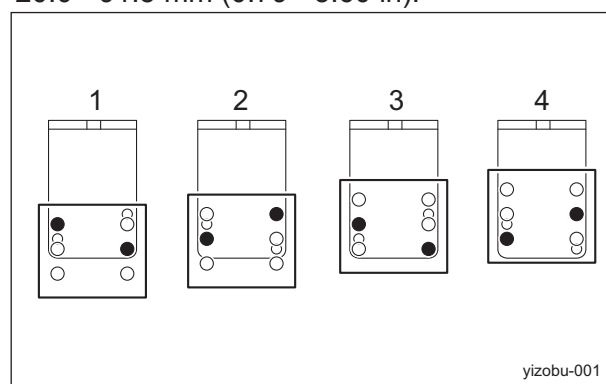

Cutting Height Table\_001

1	Adjusting plate position 1
2	Adjusting plate position 2
3	Adjusting plate position 3
4	Adjusting plate position 4

# Handling Instructions

Adjusting Plate Position	1	2	3	4
Adjusting Collars Inserted Under Cutting Height Adjusting Plate (Qty)	Cutting Height			
0	20.0 mm (0.79 in)	30.0 mm (1.18 in)	45.5 mm (1.79 in)	55.5 mm (2.19 in)
1	26.0 mm (1.02 in)	36.0 mm (1.42 in)	51.5 mm (2.03 in)	61.5 mm (2.42 in)
2	32.0 mm (1.26 in)	42.0 mm (1.65 in)	57.5 mm (2.26 in)	67.5 mm (2.66 in)
3	38.0 mm (1.50 in)	48.0 mm (1.89 in)	63.5 mm (2.50 in)	73.5 mm (2.89 in)
4	44.0 mm (1.73 in)	54.0 mm (2.13 in)	69.5 mm (2.74 in)	79.5 mm (3.13 in)
5	50.0 mm (1.97 in)	60.0 mm (2.36 in)	75.5 mm (2.97 in)	85.5 mm (3.67 in)
6	56.0 mm (2.20 in)	66.0 mm (2.60 in)	81.5 mm (3.21 in)	91.5 mm (3.60 in)

**Note:**

The factory default cutting height is 48.0 mm (1.89 in).

### Adjustment With Adjusting Collars

Adjusting collars are installed at three locations on each mower deck.

**Important**

The length of grass cut off at any one time must be no more than 30.0 mm (1.18 in).

**Important**

Do not cut off more than 1/3 of the grass height.

1. Apply the parking brake, and then lower all mower decks.
2. Stop the engine, and then remove the key.

3. Loosen the nuts securing the adjusting collars at the three locations.

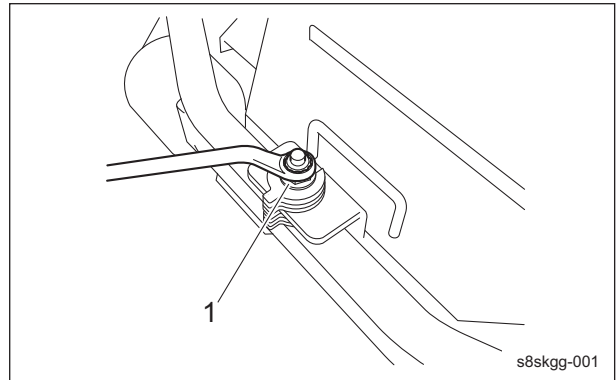

Adjustment With Adjusting Collars\_001

1	Nut
---	-----

4. Refer to the Cutting Height Table, and then adjust the number of adjusting collars at the three locations.

[1] To increase cutting height:

Remove an upper adjusting collar and insert it below.

[2] To decrease cutting height:

Remove a lower adjusting collar and insert it above.

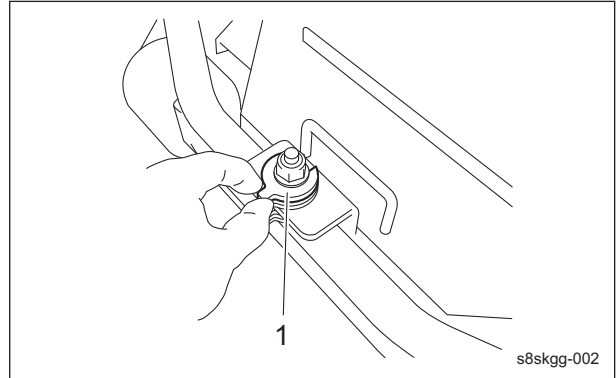

Adjustment With Adjusting Collars\_002

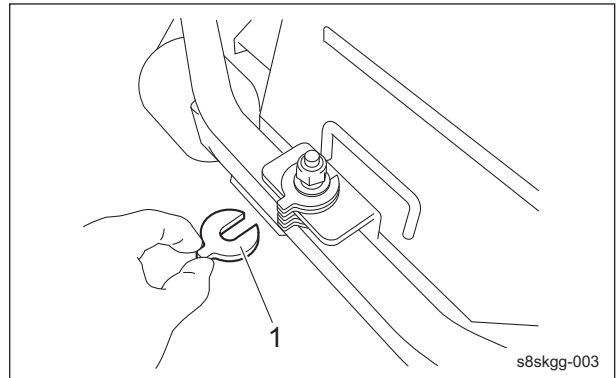

Adjustment With Adjusting Collars\_003

1	Adjusting collar
---	------------------

# Handling Instructions

5. After adjusting the adjusting collars at the three locations, firmly tighten all nuts.

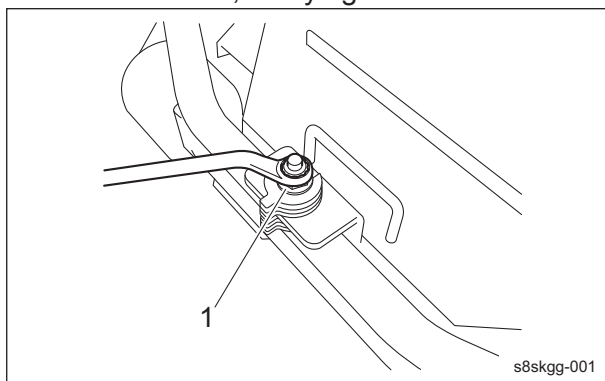

Adjustment With Adjusting Collars\_004

1	Nut
---	-----

## Adjustment With Cutting Height Adjusting Plates

Cutting height adjusting plates are installed at three locations on each mower deck.

### Important

The length of grass cut off at any one time must be no more than 30.0 mm (1.18 in).

### Important

Do not cut off more than 1/3 of the grass height.

1. Apply the parking brake, and then lower all mower decks.
2. Stop the engine, and then remove the key.
3. Loosen the six bolts securing the cutting height adjusting plates at the three locations on the mower deck.

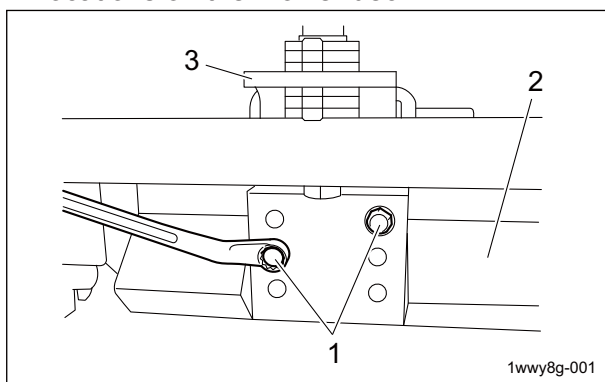

Adjustment With Cutting Height Adjusting Plates\_001

1	Bolt
2	mower deck
3	Cutting height adjusting plate

4. Refer to the Cutting Height Table, and then change the hole positions.

[1] To increase cutting height:

- a. While lifting the handle at each location on the mower deck, remove the two bolts.
- b. Raise the mower deck to change the hole positions, and then temporarily secure it with the two bolts.

[2] To decrease cutting height:

- a. While lifting the handle at each location on the mower deck, remove the two bolts.
- b. Lower the mower deck to change the hole positions, and then temporarily secure it with the two bolts.

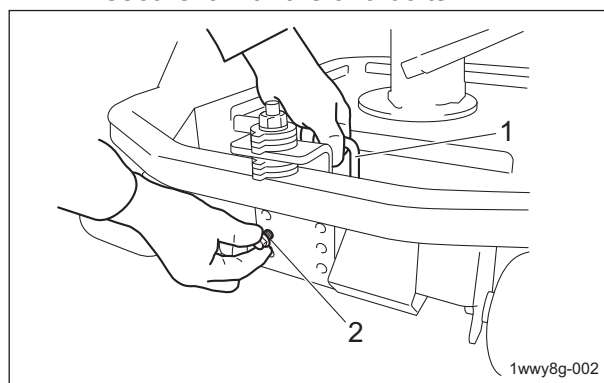

Adjustment With Cutting Height Adjusting Plates\_002

1	Handle
2	Bolt

5. After making adjustments at the three locations, firmly tighten all bolts.

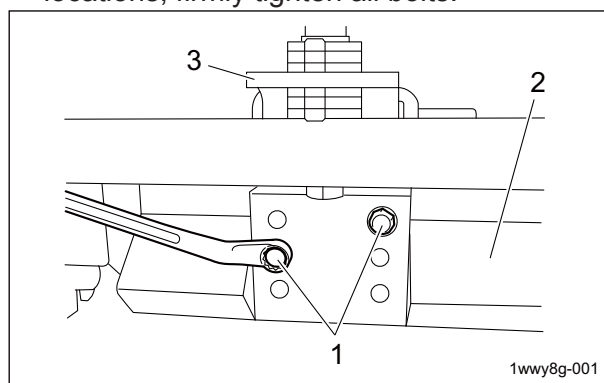

Adjustment With Cutting Height Adjusting Plates\_003

1	Bolt
2	mower deck
3	Cutting height adjusting plate

# Handling Instructions

## Procedure to Start/Stop Engine

### Start/Stop of Engine

#### Procedure to Start Engine

#### Caution

Before starting the engine, make sure that there are no other people or obstacles around the machine.

#### Important

When restarting the engine after it has been turned off, wait until the electromagnetic pump has fully stopped before restarting the engine. The electromagnetic pump will stop approximately 7 seconds after the key switch is turned to the "OFF" position.

#### Important

Starter operation must take 15 seconds or less.  
If the engine does not start, stop using the battery for 30 to 60 seconds to avoid exhausting the battery.

1. Sit on the seat.
2. Make sure that the parking brake is applied.
3. Make sure that the knife rotation switch is in the "Stop" position.
4. Make sure that the traveling pedal is in the neutral position.
5. Move the throttle knob halfway from the "Low speed" position toward the "High speed" position.
6. Switch the ignition key to the "ON (GLOW)" position.

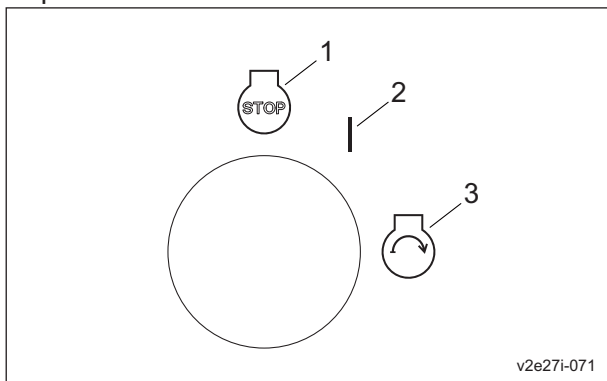

Procedure to Start Engine\_001

1	OFF
2	ON (GLOW)
3	START

#### Important

When the ignition key is switched to the "ON" position, "Warming up" may appear in the monitor display.  
Do not start the engine until the message disappears.

7. Make sure that the glow plug is generating heat, the "BARONESS" logo or "Warming up" message appears in the monitor display, and the yellow and red LEDs are lit.

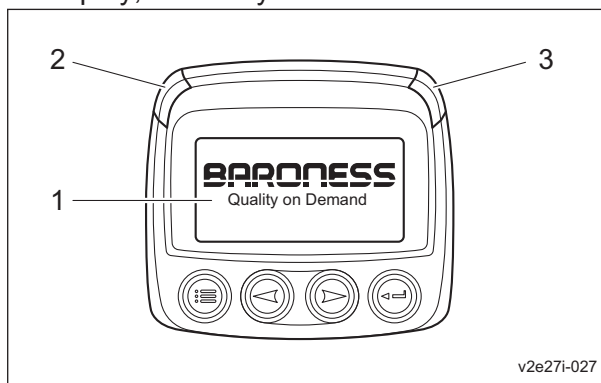

Procedure to Start Engine\_002

1	Monitor display
2	Yellow LED
3	Red LED

#### Important

Quickly returning the ignition key from the "START" position to the "ON" position may result in damage to the machine.

8. After the "BARONESS" logo and the yellow and red LEDs go off and the parameters (items and values such as the rotation speed) appear, immediately set the ignition key to the "START" position.
9. When the starter starts rotating and the engine starts, slowly return the ignition key to the "ON" position.
10. Move the throttle knob to the "Low speed" position, and then warm up the engine for 1-2 minutes.
11. Gradually move the throttle knob toward the "High speed" position.

# Handling Instructions

## Procedure to Stop Engine

1. Set the traveling pedal to the neutral position.
2. Apply the parking brake.
3. Set the knife rotation switch to the "Stop" position.
4. Raise the mower decks.
5. Shift the throttle knob to the "Low speed" position, and then idle the machine for 1-2 minutes.
6. Switch the ignition key to the "OFF" position.
7. Make sure that the engine has stopped.
8. Hook the mower lock levers (latches) for the mower decks #4 and #5.
9. Remove the ignition key.
10. Leave the driver's seat.

## Safety Mechanisms

This machine features a safety device for starting/stopping the engine.

1. As for starting the engine, the safety device prevents the engine from starting unless it meets each of the following four conditions.
  - An operator is sitting on the seat.
  - The parking brake is applied.
  - The knife rotation switch is set to the "Stop" position.
  - The traveling pedal is set to the neutral position.

### Important

When you restart the engine after the safety device stops the engine, be sure to return the ignition key to the "OFF" position first, and then restart it. Otherwise the engine does not start.

2. In the event the operator leaves the seat with the parking brake applied and the engine running, the safety device will be activated and will stop the engine under any of the following conditions:
  - The traveling pedal is not set to the neutral position. (The operator has depressed the traveling pedal.)
  - The knife rotation switch is set to the "Rotation" position.

## Warning Mechanisms

### Important

When the buzzer (intermittent tone) sounds, be sure to stop operation since the engine is overheated.

Do not stop the engine without idling. Allow the engine to cool down, first. Keep the engine idling for about 5 minutes before stopping. Remove dust that is jamming in the radiator, air cleaner, and etc.

This machine features warning mechanisms for overheating, the hydraulic oil and the engine.

1. If the engine water temperature exceeds 110 degrees Celsius, a buzzer will sound. (intermittent tone)
2. If the oil level in the hydraulic tank declines from the specified level by approximately 2.0 dm<sup>3</sup> (2.0 L), a buzzer will sound. (continuous tone)
3. With an engine malfunction, a monitor LED lights up and a fault code appears.



# Handling Instructions

## Operation Method

### Cautions for when You Leave The Machine

**Caution**

If the brakes are not sufficiently effective, use the wheel stoppers to secure the machine.

**Caution**

Never park the machine on a slope.

1. Park the machine on level ground.
2. Apply the parking brake.
3. Stop the engine.
4. Remove the ignition key.
5. Leave the machine.

### Positions of Operation Decals

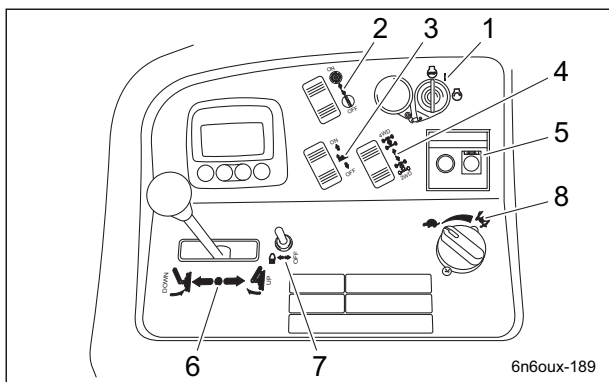

Positions of Operation Decals\_001

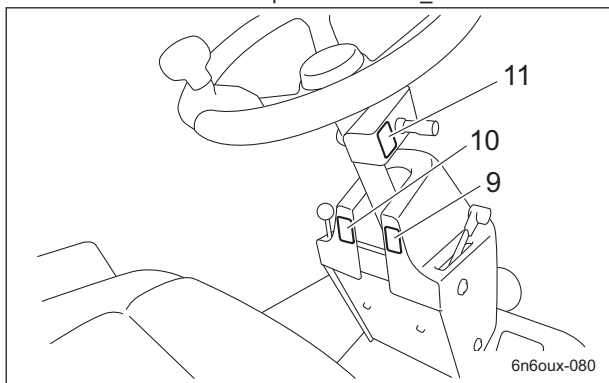

Positions of Operation Decals\_002

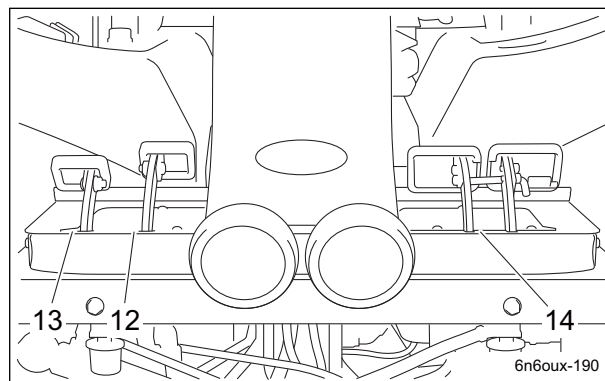

Positions of Operation Decals\_003

1	Key switch decal
2	Knife rotation mark
3	Traction assist mark
4	2WD/4WD selector mark
5	DPF regeneration mark (EN)
6	Mower deck up/down mark
7	Light switch mark
8	Engine rotation mark
9	Tilt Steering decal
10	Parking brake decal
11	Differential lock decal
12	FORWARD decal
13	BACKWARD decal
14	BRAKE Decal

### Description of Operation Decals

#### Key Switch Decal

Decal, key switch

This indicates the key switch positions.

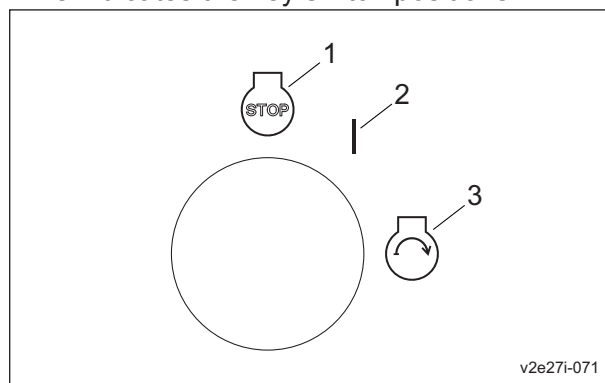

Key Switch Decal\_001

1	OFF
2	ON (GLOW)
3	START



# Handling Instructions

## Knife Rotation Mark

Knife rotation mark  
It illustrates Rotation/Stop of the rotary knife.

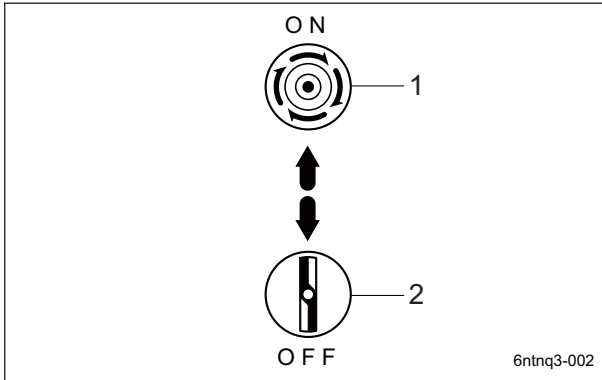

Knife Rotation Mark\_001

1	Rotation
2	Stop

## 2WD/4WD Selector Mark

2WD/4WD selector mark  
This indicates the 2WD/4WD positions.

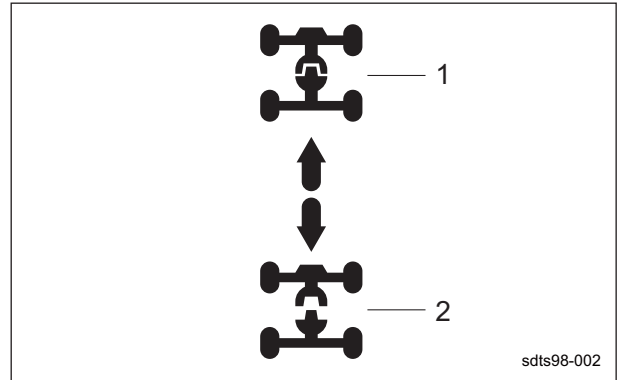

2WD/4WD Selector Mark\_001

1	4WD
2	2WD

## Traction Assist Mark

Traction assist mark  
It illustrates Activate/ Deactivate of the traction assist.

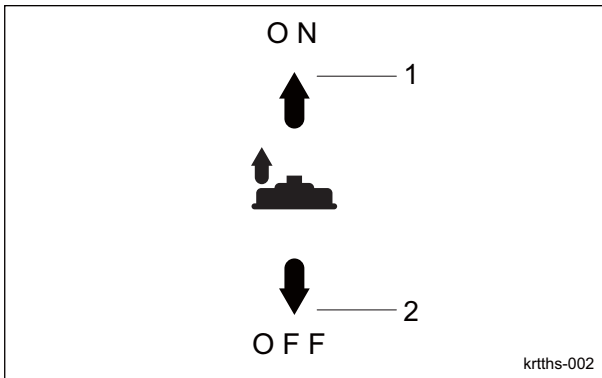

Traction Assist Mark\_001

1	Activate
2	Deactivate

## DPF Regeneration Mark (EN)

-  
DPF regeneration mark (EN)  
This indicates the changeover of DPF regeneration.

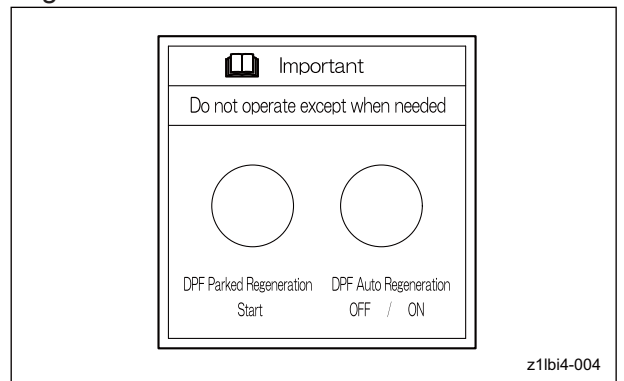

DPF Regeneration Mark (EN)\_001

# Handling Instructions

## Mower Deck Up/Down Mark

Mower deck up/down mark  
This indicates the Up/Down positions of the mower deck.

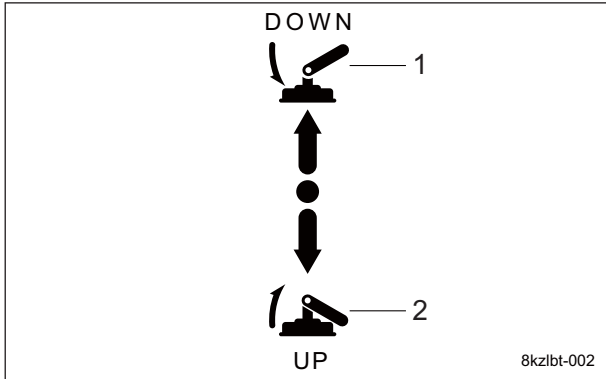

Mower Deck Up/Down Mark\_001

1	Down
2	Up

## Engine Rotation Mark

Engine rotation mark  
This indicates low/high speed of engine rotation.

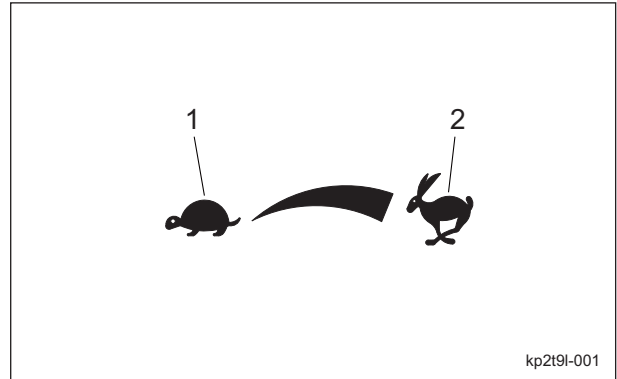

Engine Rotation Mark\_001

1	Low speed
2	High speed

## Light Switch Mark

Note:  
Depending on the specifications, this function may not be available.  
Light switch mark  
It illustrates ON/OFF of the light.

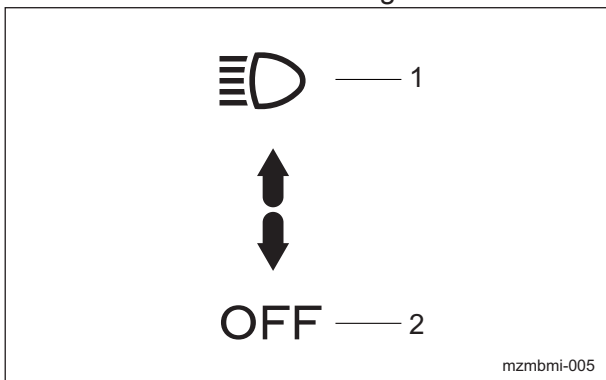

Light Switch Mark\_001

1	ON
2	OFF

## Differential Lock Decal

K4203001420  
Decal, differential lock  
This indicates the positions for engaging or releasing the differential lock.

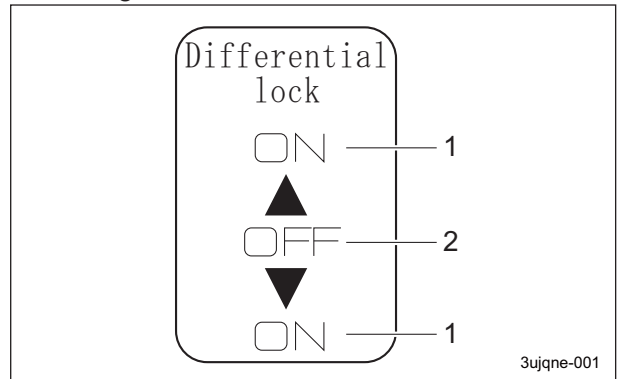

Differential Lock Decal\_001

1	Engage
2	Release

# Handling Instructions

## Tilt Steering Decal

K4203001350  
Decal, tilt steering  
This illustrates the tilt directions of the steering wheel and the locked/free positions.

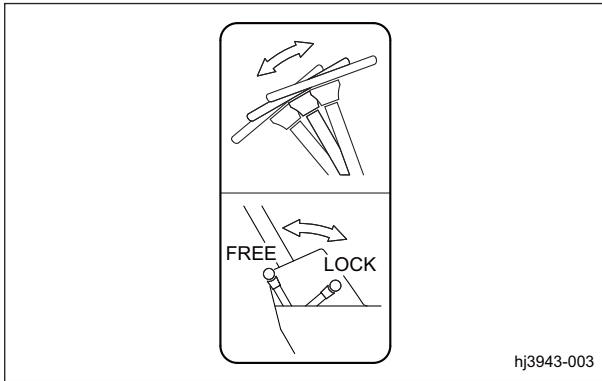

Tilt Steering Decal\_001

## FORWARD Decal

K4203001430  
Decal, FORWARD  
This indicates forward travel.



FORWARD Decal\_001

## Parking Brake Decal

K4203001340  
Parking brake decal  
This shows how to lock and release the parking brake.

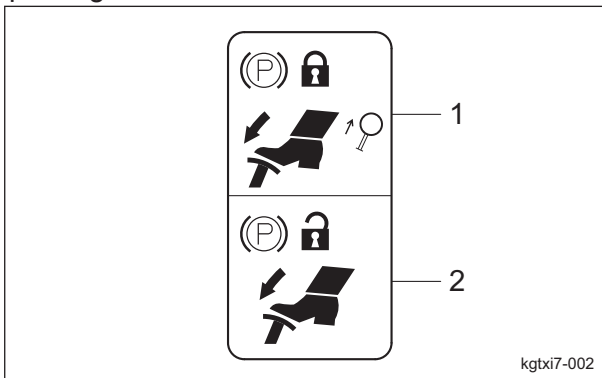

Parking Brake Decal\_001

1	Lock
2	Release

## BACKWARD Decal

K4203001440  
Decal, BACKWARD  
This indicates backward travel.

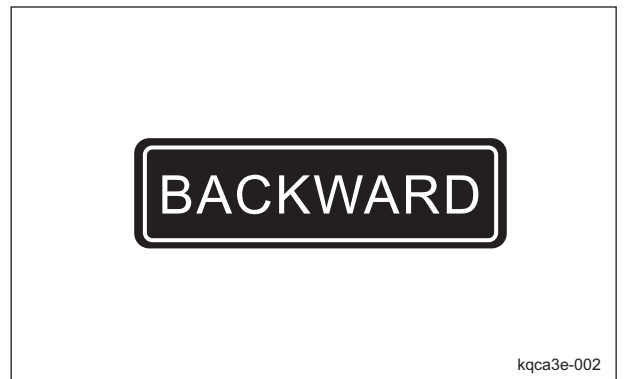

BACKWARD Decal\_001

## BRAKE Decal

K4203001450  
Decal, BRAKE  
This indicates brake.



BRAKE Decal\_001

# Handling Instructions

## Proximity Sensors

There are two proximity sensors on mower arm fulcrums #4 and #5.

These sensors detect the raised or lowered positions of mower decks #4 and #5.

The information is related to controlling rotation and stop of the rotary knives.

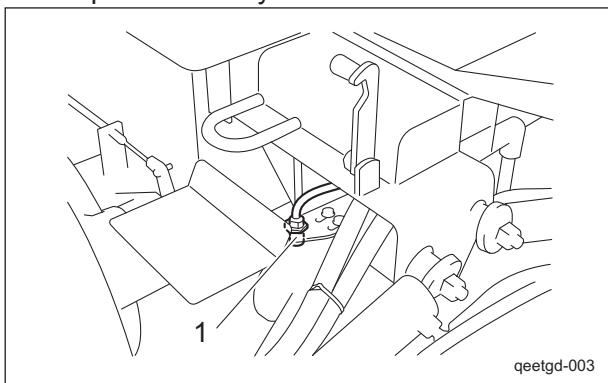

Proximity Sensors\_001

1	Proximity sensors
---	-------------------

## Relays

The relay box is at the front of the right hood.

These relays control operation of the diff-lock valve, rotation of the rotary knives, 2WD/4WD selection and traction assist selection.

The operating condition can be checked by the illumination of the LEDs.

- LEDs ①, ② and ③ light up when the diff-lock valve is in the "ON" position.
- LED ④ lights up when the traction assist switch is in the "ON" position.
- LEDs ⑤ and ⑥ light up when the knife rotation switch is in the "ON" position and the mower deck is lowered.
- LED ⑦ lights up when the knife rotation switch is in the "ON" position, and then the machine enters 4WD.
- LED ⑧ lights up when the 2WD/4WD selector switch is in the "4WD" position, and then the machine enters 4WD.

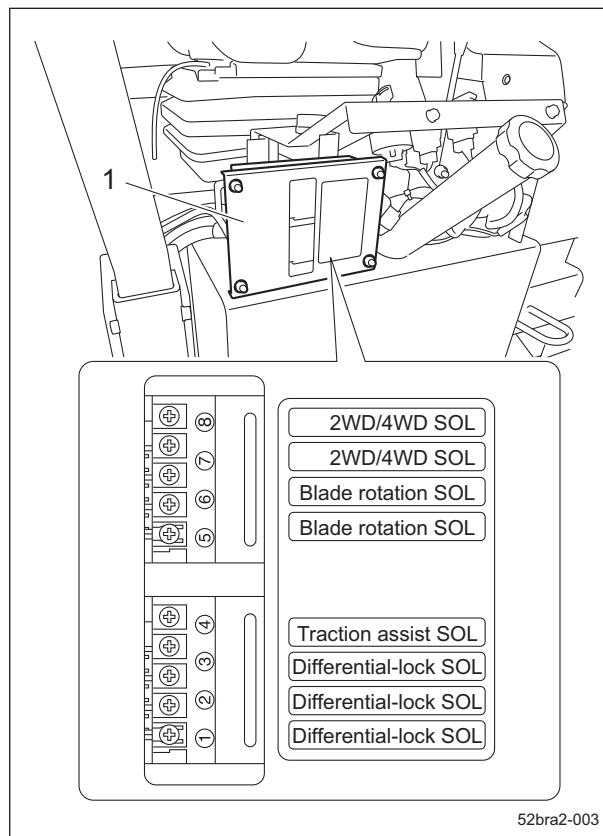

Relays\_001

1	Relay box
---	-----------

# Handling Instructions

## Knife Rotation Switch

**Caution**

Set the knife rotation switch to the "Rotation" position immediately before starting cutting work. At all other times, be sure to leave the knife rotation switch set to the "Stop" position.

**Important**

Be sure to switch when the machine stops. Otherwise, the hydraulic system will malfunction.

The knife rotation switch is located in the operation panel and operates rotation of the rotary knives of the mower decks.

When the knife rotation switch is set to the "Rotation" position, the rotary knives of all mower decks will rotate.

When the knife rotation switch is set to the "Stop" position, the rotary knives will stop.

Note:

When the mower decks are raised, the rotary knives do not rotate, even if the switch is set to the "Rotation" position.

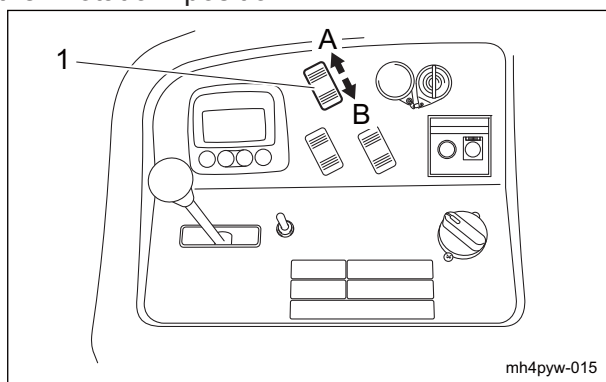

Knife Rotation Switch\_001

1	Knife rotation switch
A	Rotation
B	Stop

## 2WD/4WD Selector Switch

**Caution**

When working on a slope, be sure to use the machine in 4WD.

**Caution**

When traveling, be sure to stop the rotation of the rotary knives and raise the mower decks.

**Important**

Be sure to switch when the machine stops. Otherwise, the hydraulic system will malfunction.

The 2WD/4WD selector switch is located in the operation panel.

When the switch is set to the "2WD" position, the machine will be in two-wheel drive (front-wheel drive). When it is set to the "4WD" position, the machine will be in four-wheel drive.

Note:

When the knife rotation switch is set to the "Rotation" position, the machine enters 4WD, regardless of the position that the 2WD/4WD selector switch is set to.

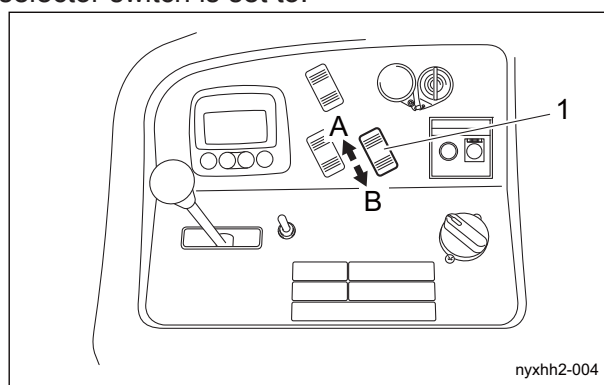

2WD/4WD Selector Switch\_001

1	2WD/4WD selector switch
A	4WD
B	2WD

# Handling Instructions

## DPF Auto Regeneration Inhibit Switch

### Caution

Normally, set the DPF auto regeneration inhibit switch to "Auto regeneration mode". However, when operating in a location where fires may occur, set the DPF auto regeneration inhibit switch to "Auto regeneration inhibit mode".

### Important

The DPF auto regeneration inhibit switch is reset to "Auto regeneration mode" when the engine is started even if the engine was stopped with the DPF auto regeneration inhibit switch set to "Auto regeneration inhibit mode".

The DPF auto regeneration inhibit switch is located in the operation panel.

The DPF auto regeneration inhibit switch is the switch for shifting between "Auto regeneration mode" and "Auto regeneration inhibit mode". With the engine running, press this switch to shift between "Auto regeneration mode" and "Auto regeneration inhibit mode".

#### • Auto regeneration mode:

The DPF auto regeneration inhibit switch is reset to "Auto regeneration mode" when the engine is started.

In "Auto regeneration mode" regeneration is automatically performed regardless of the main vehicle's travel and stop on the condition that a specific amount of PM is accumulated and the requirements for DPF regeneration are fulfilled.

#### • Auto regeneration inhibit mode:

In order to set to "Auto regeneration inhibit mode", press the DPF auto regeneration inhibit switch after the engine is started.

In "Auto regeneration inhibit mode" PM accumulates in the DPF and PM accumulation level increases.

Unless the operator implements regeneration on his own will, regeneration is not performed.

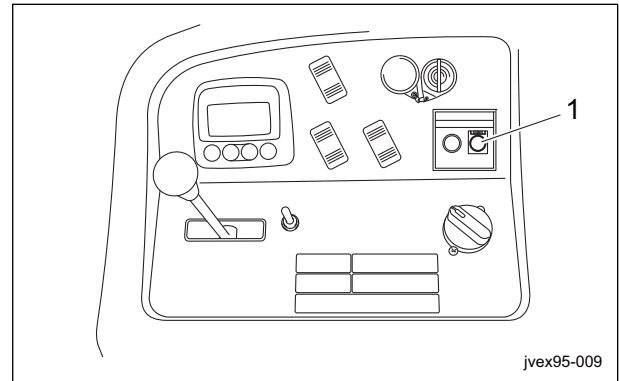

DPF Auto Regeneration Inhibit Switch\_001

1 DPF auto regeneration inhibit switch

When the DPF auto regeneration inhibit switch is pressed and set to "Auto regeneration inhibit mode", the monitor displays Auto regeneration inhibit icon.

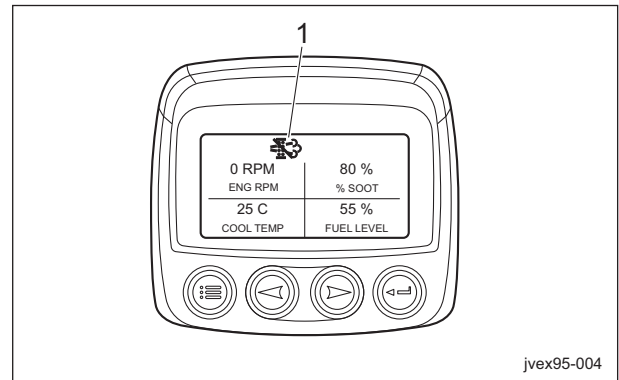

DPF Auto Regeneration Inhibit Switch\_002

1 Auto regeneration inhibit icon

# Handling Instructions

## DPF Parked Regeneration Switch

**Danger**

Do not perform DPF regeneration in a location where fires may occur since it will become extremely hot around the exhaust outlet during DPF regeneration.

**Important**

If parked regeneration is not required, it will not start even if the switch is pressed.

The DPF parked regeneration switch is located in the operation panel.

The DPF parked regeneration switch is the switch for actuating parked regeneration.

When the regeneration icon is blinking, press the switch to start parked regeneration.

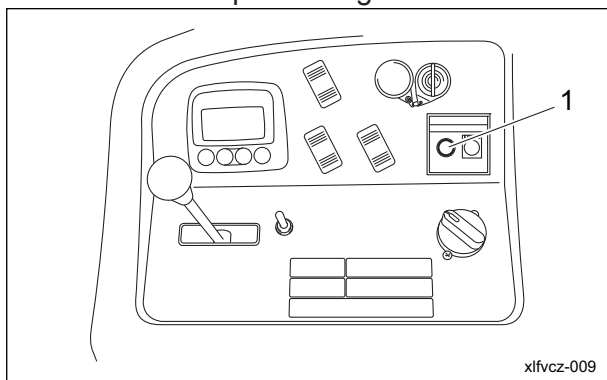

DPF Parked Regeneration Switch\_001

1	DPF parked regeneration switch
---	--------------------------------

When parked regeneration starts, Regeneration icon in the monitor display changes from blinking to lighting.

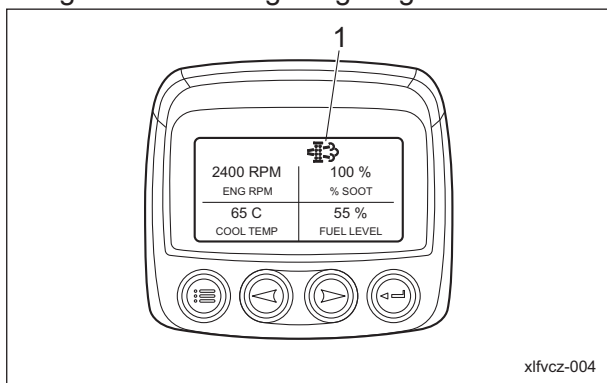

DPF Parked Regeneration Switch\_002

1	Regeneration icon
---	-------------------

## Light Switch

Note:

Depending on the specifications, this function may not be available.

**Caution**

The lights provide auxiliary lighting. Do not travel or operate the machine at night or under poor visibility.

The light switch is located in the operation panel.

When the switch is set to the "ON" position, the lights turn on. When it is set to the "OFF" position, the lights turn off.

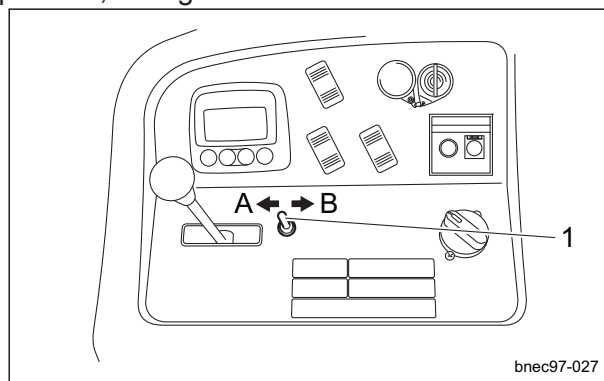

Light Switch\_001

1	Light switch
A	ON (turn on)
B	OFF (turn off)

# Handling Instructions

## Traction Assist Switch

The traction assist switch is located in the operation panel.

This switch is effective to increase climbing ability when this machine is in cutting operation (4WD).

- The cylinders are pressurized even with the switch set to the "OFF" position and so the mower decks are a little raised.
- When the switch is set to the "ON" position, the traction assist mode is automatically switched and the power lifting the mower decks and climbing ability are increased.
- When the switch is set to the "ON" position and the machine is in cutting operation on a slope of 13 degrees or more, the power lifting the mower decks and climbing ability are further increased.

Note:

Tracking may be impaired if the machine is used with the switch set to the "ON" position in an area with many undulations.

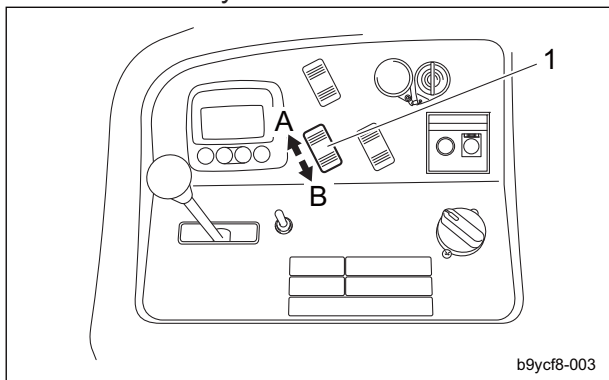

Traction Assist Switch\_001

1	Traction assist switch
A	ON
B	OFF

## Mower Lock Lever (Latch)

The mower lock levers (latches) are located in the foot area on the left and right sides. Hook the mower lock levers (latches) on the arms to keep the mower decks #4 and #5 raised.

The mower lock levers (latches) may be used for the following operations.

- Moving by the machine
- Transporting the machine
- Storing the machine

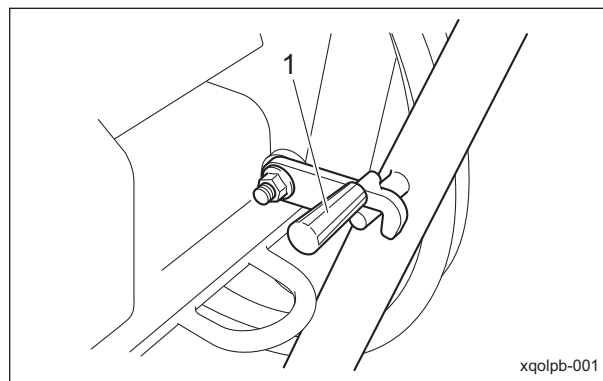

Mower Lock Lever (Latch)\_001

1	Mower lock lever (latch)
---	--------------------------

## Mower Deck Up/Down Lever

### Caution

Before raising or lowering the mower decks, make sure that there are no people around the machine.

### Important

When the mower lock levers (latches) are engaged, do not operate the mower deck up/down lever.

The mower deck up/down lever is located in the operation panel and raises or lowers the mower decks.

When the lever is shifted to the "Lower" position, the mower decks are lowered. When the lever is shifted to the "Raise" position, the mower decks are raised.

Release the lever to return it to the neutral position.

Note:

When the mower decks are raised, the rotary knives stop rotating, even if the knife rotation switch is set to the "Rotation" position.

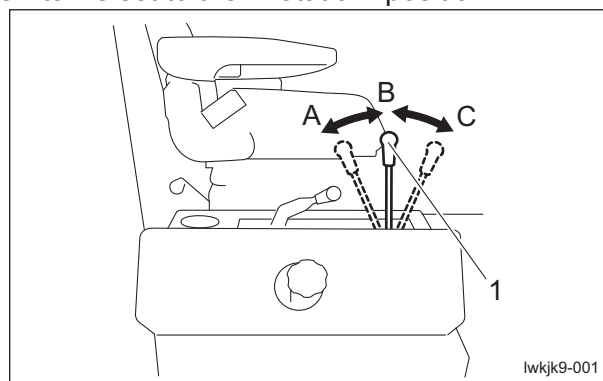

Mower Deck Up/Down Lever\_001



# Handling Instructions

1	Mower deck up/down lever
A	Raise
B	Neutral
C	Lower

## Throttle Knob

The throttle knob is located to the right of the driver's seat and enables you to adjust the engine rpm.

Move the throttle knob toward the "High speed" position to increase the engine rpm, and toward the "Low speed" to reduce the rpm.

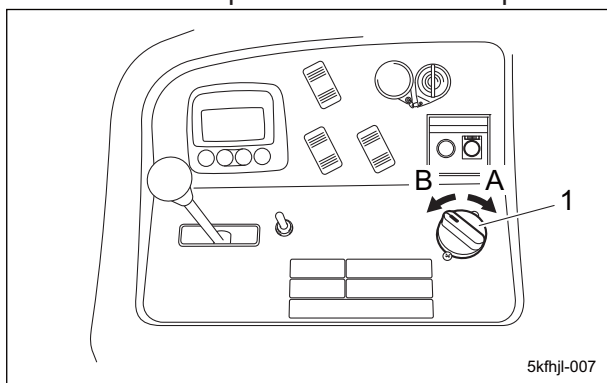

Throttle Knob\_001

1	Throttle knob
A	High speed
B	Low speed

## Diff-Lock Switch

### Important

Do not operate the diff-lock switch unless it is necessary.

The diff-lock switch is located below the right side of the steering wheel and engages the differential lock for the left and right front wheels.

Tilt the switch lever up or down to turn "ON" to engage the differential lock for the front wheels.

Release the switch lever to return it to the neutral position ("OFF" position) and disengage the differential lock.

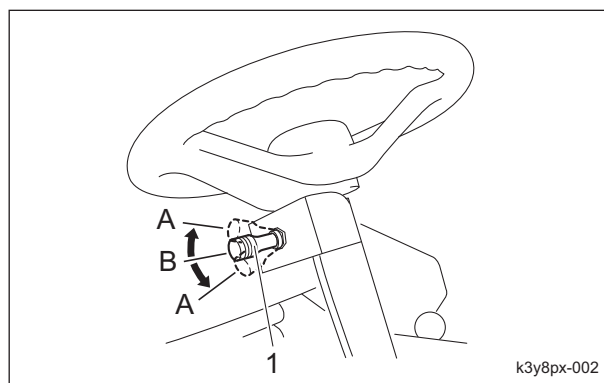

Diff-Lock Switch\_001

1	Diff-lock switch
A	ON (Lock)
B	OFF (Release)

## Traveling Pedal

### Caution

When the machine is traveling at a high speed, it will not stop immediately after you take your foot off the traveling pedal. If necessary, also use the brake.

The traveling pedals are located in the right foot area and control forward and reverse operation of the machine. When the forward pedal (inside) is depressed, the machine travels forward. When the reverse pedal (outside) is depressed, the machine travels in reverse.

The speed changes in accordance with how much the pedal is depressed.

When you take your foot off the pedal, the machine stops automatically.

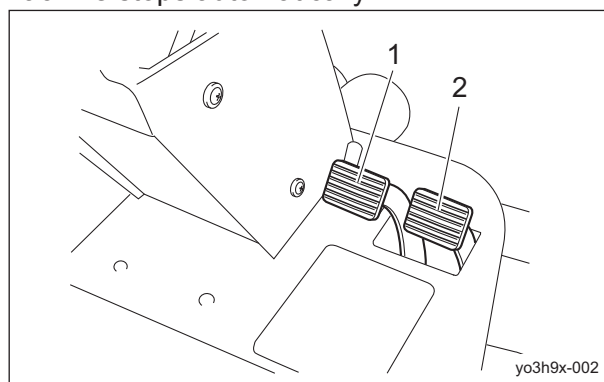

Traveling Pedal\_001

1	Forward pedal
2	Reverse pedal

# Handling Instructions

## Brake Pedal

**Warning**

Link the brake pedals, except when operating the machine.  
Using the brake pedals without linking them may result in the machine overturning.

**Important**

When depressing the brake pedals to make turns with a small radius, obtain a sufficient awareness of the lawn and ground conditions. This will damage the lawn.

The brake pedals are located in the left foot area and operate the left and right brakes independently.

By depressing the brake pedal on the side in which the turn will be made, the machine can make turns with a small radius.

If the front wheel on the upward side of a slope slips, depress the brake pedal for the wheel on the upward side in order to increase the traction of the wheel on the downward side and stabilize travel.

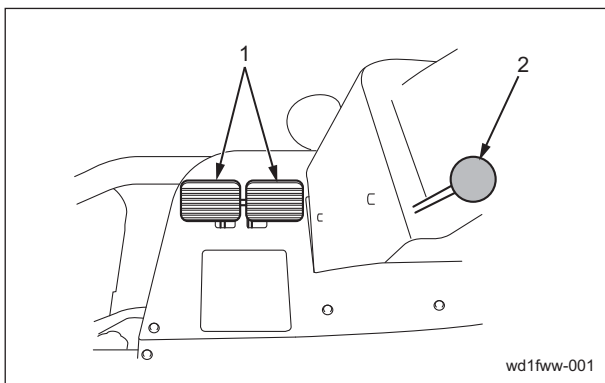

Brake Pedal\_001

1	Brake pedals
2	Parking brake lever

## Change of Braking Method

Follow the procedure below to change the braking method from linked to independent.

1. Swing up the pedal link bar, and then pull it out from the right brake pedal.

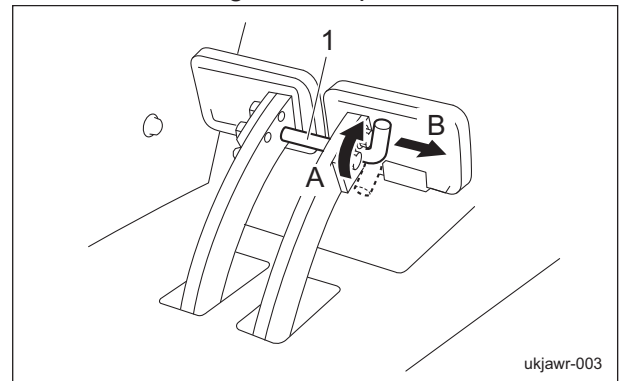

Change of Braking Method\_001

1	Pedal link bar
A	Swing up
B	Pull out

2. Secure the pedal link bar in the holder on the left brake pedal.

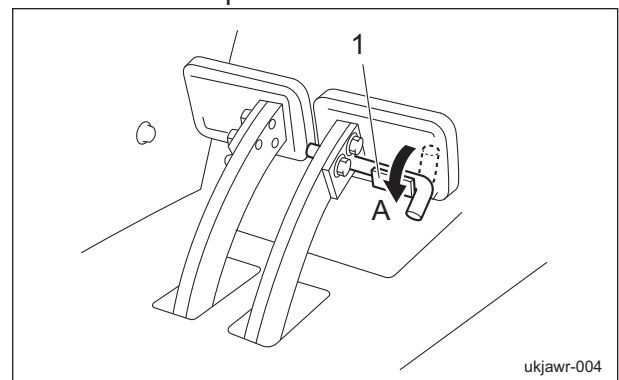

Change of Braking Method\_002

1	Holder
A	Secure

# Handling Instructions

## Parking Brake Lever

### ⚠ Caution

Never park the machine on a slope.

### Important

Be sure to release the parking brake before driving. It may result in the brakes or hydraulic system malfunction.

The parking brake lever is located to the left of the front cover.

When parking, link the left and right brake pedals by using the pedal link bar, depress both brake pedals, and then pull the parking brake lever completely.

To release the parking brake, depress the brake pedals.

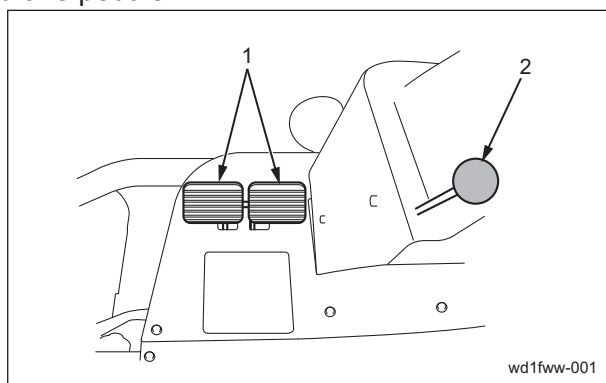

Parking Brake Lever\_001

1	Brake pedals
2	Parking brake lever

## Hood

### ⚠ Caution

Do not open the hood in strong winds.

### ⚠ Caution

Be careful not to pinch your fingers when you open or close the hood.

1. Unlock the rubber catch, and then lift up the hood.
2. Hook the hood support rod onto the latch inside the hood.  
Make sure that the hood will not close, and then remove your hands.

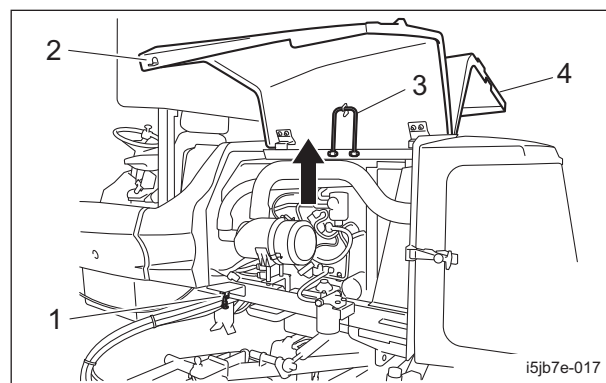

Hood\_001

1	Rubber catch
2	Left hood
3	Hood support rod
4	Right hood

3. To close the hood, release the hood support rod from the latch, and then lower the hood slowly.

4. Lock the rubber catch securely.

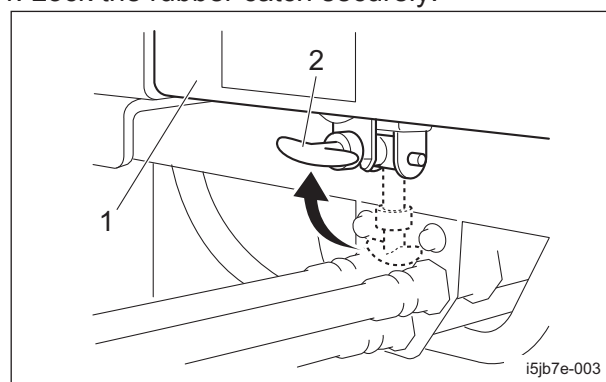

Hood\_002

1	Hood
2	Rubber catch

# Handling Instructions

## Underseat Cover

1	Monitor display
2	LED (yellow)
3	LED (red)
4	Enter key
5	Right arrow key
6	Left arrow key
7	Menu key

**Caution**

Be careful not to pinch your fingers when you open or close the underseat cover.

1. Make sure that the steering wheel is raised completely.
2. Bring the seat to the backmost position.
3. Pull up the lever behind the seat to unlock it.

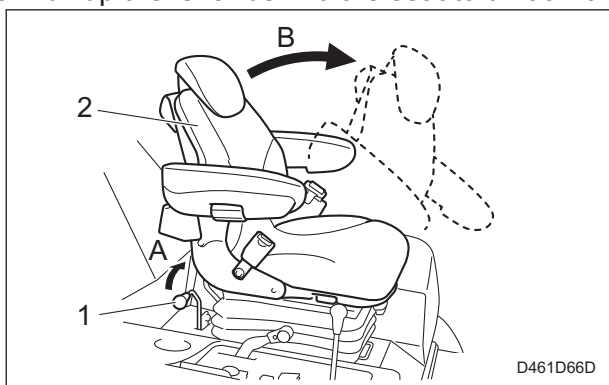

Underseat Cover\_001

1	Lever
2	Seat
A	Pull up
B	Tilt forward

4. Tilt the seat forward to open the cover.  
To close the cover, slowly lower the seat.

1. Monitor display  
Displays machine conditions and items.
2. LED (yellow)  
Lights up when a malfunction is detected, indicating warning and/or caution on the engine.
3. LED (red)  
Lights up when a critical malfunction on the engine is detected.
4. Enter key  
Selects the menu or parameter.  
Switches between displaying/hiding the current fault code.
5. Right arrow key  
Scrolls the screen.  
Move the parameter selection to the right or down.
6. Left arrow key  
Scrolls the screen.  
Move the parameter selection to the left or up.
7. Menu key  
Opens or exits the menu.

## Instruments

### Description of Monitor

The monitor displays various information about the machine, such as the operating status and fault conditions.

The information of desired items can be confirmed according to operating the keys.

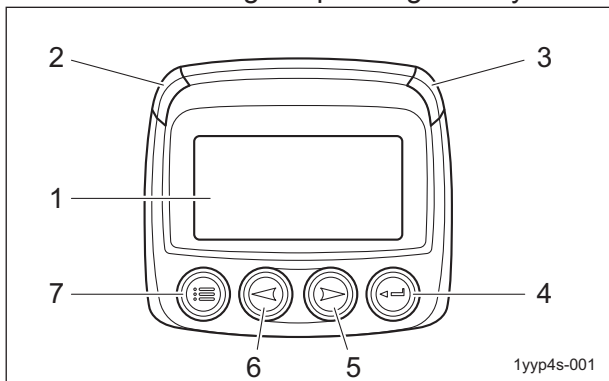

Description of Monitor\_001

# Handling Instructions

## Displayed Icon

The icon appears at the top of the monitor display.

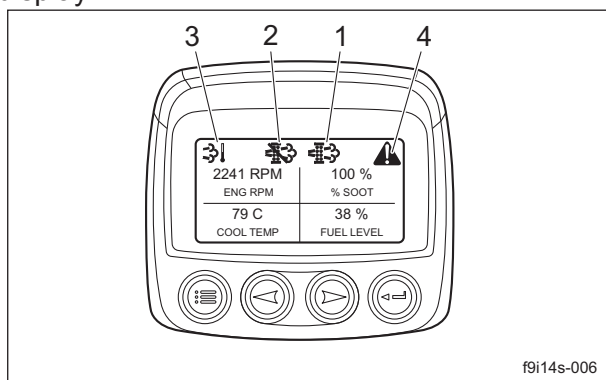

Displayed Icon\_001

1	Regeneration icon
2	Auto regeneration inhibit icon
3	High exhaust temperature icon
4	Warning mark

### 1. Regeneration icon

The regeneration icon appears with DPF regeneration request or during DPF regeneration.

- DPF regeneration request: Blinking
- During DPF regeneration: Lighting

### 2. Auto regeneration inhibit icon

The auto regeneration inhibit icon lights up when the DPF auto regeneration inhibit switch is set to the "Auto regeneration inhibit mode".

### 3. High exhaust temperature icon

The high exhaust temperature icon lights up when the exhaust temperature reaches 450 °C during DPF regeneration.

### 4. Warning mark

The warning mark continues to be displayed in the upper right corner of the monitor display if the warning message ignored and the Enter key pressed to hide the message.

- Service reminders
- Low fuel level
- Fault codes

## Main Menu Items

While any parameter is displayed, press the menu key to display the main menu with the following 11 items.

- GO TO 1-UP DISPLAY / GO TO 4-UP DISPLAY
- LANGUAGES
- STORED CODES
- ENGINE CONFIGURATION
- SETUP 1-UP DISPLAY
- SETUP 4-UP DISPLAY
- SERVICE REMINDERS
- SELECT UNITS
- ADJUST BACKLIGHT
- ADJUST CONTRAST
- UTILITIES

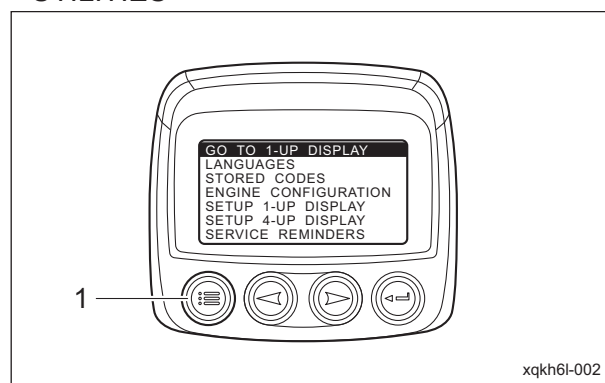

Main Menu Items\_001

1	Menu key
---	----------

## 1-Up Display / 4-Up Display

"GO TO 1-UP DISPLAY" / "GO TO 4-UP DISPLAY" are used to set whether to display parameters individually in a screen or in groups of four per screen.

### 1. 1-up display

One parameter is displayed individually in the monitor display.

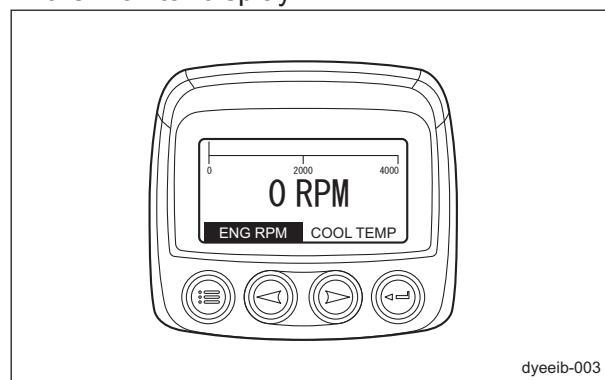

1-Up Display / 4-Up Display\_001

# Handling Instructions

---

## 2. 4-up display

Four parameters are displayed in the monitor display.

With the 4-up display, a total of 8 parameters are displayed over 2 pages.

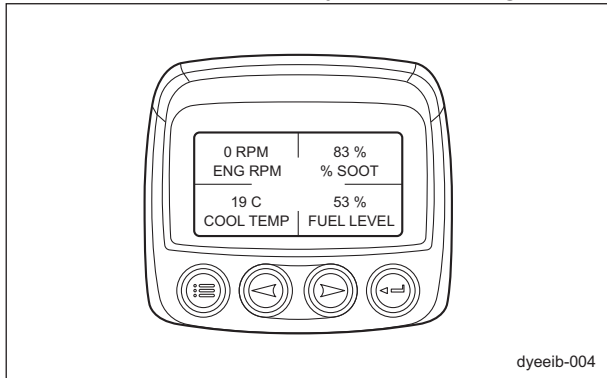

1-Up Display / 4-Up Display\_002

### Note:

The factory default display is the 4-up display. "GO TO 1-UP DISPLAY" appears in the main menu.

When the 1-up display is set, "GO TO 4-UP DISPLAY" appears in the main menu.

# Handling Instructions

## ■Parameter Items

The parameters and corresponding information that appear in the monitor display are listed below.

No.	Monitor display L	Monitor display S	Description
1	ENGINE SPEED	ENG RPM	Displays the engine rpm.
2	DRIVERS DEMAND ENGINE TORQUE	DEMAND TQ	Displays the torque required by the ECU.
3	ACTUAL ENGINE TORQUE	ENG TORQ	Displays the actual torque.
4	PERCENT LOAD AT CURRENT RPM	LOAD@RPM	Displays the engine load factor.
5	ACCELERATOR PEDAL POSITION 1	ACCEL PED1	Displays the accelerator sensor opening.
6	ENGINE DESIRED OP SPEED	DES ENG SP	Displays the engine rpm required by the ECU.
7	ENGINE COOLANT TEMPERATURE	COOL TEMP	Displays the temperature measured by the coolant temperature sensor.
8	FUEL RATE	FUEL RATE	Displays the engine fuel consumption rate.
9	THROTTLE POSITION	THROTTLE	Displays the engine throttle opening.
10	BOOST PRESSURE	BST PRES	Displays the pressure measured by the intake pressure sensor.
11	INTAKE MANIFOLD TEMPERATURE	MANI TEMP	Displays the temperature measured by the intake temperature sensor built into the air flow sensor.
12	BATTERY POTENTIAL	BAT VOLT	Displays the battery voltage.
13	BAROMETRIC PRESSURE	BARO PRES	Displays the atmospheric pressure measured by the atmospheric pressure sensor.
14	AMBIENT AIR TEMP	AMB TEMP	Displays the ambient temperature.
15	AIR INLET TEMPERATURE	AIR IN TP	Displays the intake air temperature measured by the air flow sensor.
16	TOTAL FUEL USED	FUEL USED	Displays the total fuel consumption of the engine.
17	TOTAL ENGINE HOURS	ENG HRS	Displays the total time that the ECU is on (time that the key is in the "ON" position).
18	ENGINE OIL PRESSURE	OIL PRES	Displays the engine oil pressure measured by the oil pressure switch. While the engine is running: Normal=200 kPa, Abnormal=0 kPa
19	INJECTOR METERRING RAIL PRESS	RAIL PRES	Displays the fuel pressure in the rail, measured by the rail pressure sensor.
20	ENGINE INLET AIR MASS FLOW RATE	AIR RATE	Displays the intake air volume measured by the air flow sensor.
21	DOC INTAKE GAS TEMP	DOC TEMP	Displays the DOC inlet gas temperature measured by the exhaust temperature sensor.
22	EXHAUST FILTER INLET TEMP	EF IN T	Displays the DPF inlet gas temperature measured by the exhaust temperature sensor.
23	DPF DIFFERENCE PRESSURE	DIFF PRES	Displays the pressure difference before and after the DPF, measured by the differential pressure sensor.

# Handling Instructions

---

No.	Monitor display L	Monitor display S	Description
24	EXHAUST FILTER OUTLET TEMP	EF OUT T	Displays the DPF outlet gas temperature measured by the exhaust temperature sensor.
25	PARTICULATE TRAP LAMP	PT LAMP	Shows the status of the regeneration icon. Icon not displayed="OFF", Icon blinking="ON BLINK", Icon solid="ON SOLID"
26	DPF STATUS	DPF ST	Shows the status of the DPF. DPF regeneration not needed="REGEN NOT NEEDED" DPF regeneration needed=(Level 1="NEEDED LOWEST", Level 2-3="NEEDED MODERATE", Level 4="NEEDED HIGHEST")
27	DPF ACTIVE REGEN STATUS	DPF AR ST	Shows the DPF regeneration status. Regeneration not needed="INACTIVE", Regeneration needed="NEEDED", Regenerating="ACTIVE"
28	DPF REGEN INHIBIT STATUS	INHIBIT ST	Shows the ECU auto regeneration inhibited status. Auto regeneration inhibit switch off="OFF", Auto regeneration inhibit switch on="ON"
29	DPF REGENERATION INHIBITED SW	DPF INHIB SW	Shows the status of auto regeneration inhibit switch. Auto regeneration inhibit switch off="OFF", Auto regeneration inhibit switch on="ON"
30	EXHAUST HIGH TEMP LAMP	EXH T LAMP	Displays the condition of the exhaust temperature. 450 °C or more="ON", 450 °C or less="OFF"
31	%SOOT	%SOOT	Displays the amount of soot accumulated in the DPF.
32	MACHINE HOURS	MACH HRS	Displays the total operating time of the machine (time that the engine was actually running).
33	FUEL LEVEL	FUEL LEVEL	Displays the quantity of fuel remaining in the fuel tank.

**Note:**

When display settings are being specified, the parameters appear on "Monitor display L".  
At all other times, the parameters appear on "Monitor display S".



# Handling Instructions

## Language

With "LANGUAGES", the language used in the monitor display can be set to either of the following two.

- ENGLISH
- JAPANESE

An asterisk appears at the right of the currently selected language.

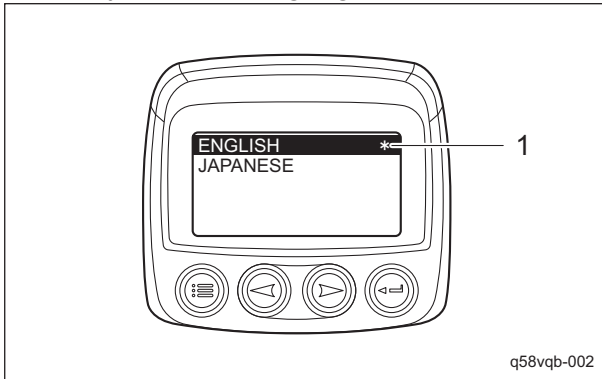

Language\_001

1	Asterisk
---	----------

**Note:**

The factory default language is "ENGLISH".

## Fault Code Log

With "STORED CODES", a log of past fault codes can be checked.

When there is a fault code log, each fault is displayed over two pages.

Use the arrow keys to change the page.

- Text 1

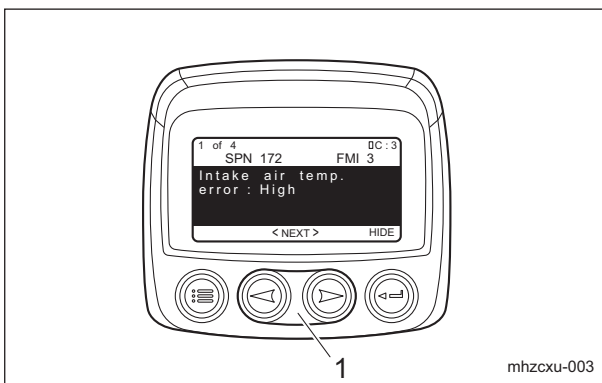

Fault Code Log\_001

1	Arrow keys
---	------------

- Text 2

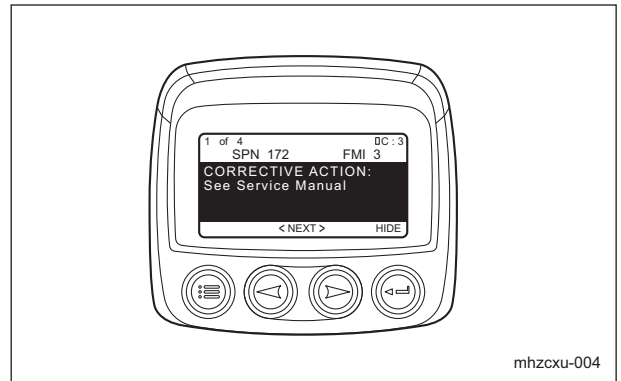

Fault Code Log\_002

If there is no fault code log, "NO STORED FAULT CODES" appears.

# Handling Instructions

## ■List of Fault Codes

### Important

When the fault code appears in the monitor display, refer to "Kubota DIAGNOSIS MANUAL COMMON RAIL SYSTEM" or contact your dealer.

The fault codes (DTC) and corresponding information that appear in the monitor display are listed below.

No.	DTC name Text 1	Corrective action Text 2	ISO 14229 P-Code	J1939-73		Detection item	Remark	Behavior During Malfunction	Recovery from error
				SPN	FMI				
1	NE-G phase shift NE: Crankshaft position sensor G: Camshaft position sensor	See Service Manual	P0016	636	7	Large phase shift between NE pulse and G pulse	<ul style="list-style-type: none"> <li>• NE: Crankshaft position sensor</li> <li>• G: Camshaft position sensor</li> </ul>	(Invalid G signal) - Engine hesitates at start-up	Diagnostic counter = zero
2	Pressure limiter emergency open	See Service Manual	P0087	633	7	Pressure limiter emergency open	To minimize PM emission to DPF Engine speed may go down due to lack of fuel pressure, regardless limp home de-rating	- Insufficient output - Worsening exhaust gas emissions	Key switch turn OFF
3	High rail pressure	See Service Manual	P0088	157	0	Actual pressure exceeds the command pressure	To minimize PM emission to DPF	- Insufficient output - Worsening exhaust gas emissions	Key switch turn OFF
4	SCV (MPROP) stuck	See Service Manual	P0089	1347	7	SCV stuck at open position (Actual rail pressure continuously exceeds the command rail pressure)	To minimize PM emission to DPF	- Insufficient output - Worsening exhaust gas emissions - Engine stops in some cases	Key switch turn OFF
5	Fuel leak (in high pressured fuel system)	Stop ENG See Service Manual	P0093	1239	1	Fuel leak from high pressured fuel system (Fuel consumption is calculated from the difference of fuel pressure of before and after the injection, and the error will be detected when excess fuel	To minimize PM emission to DPF	- Insufficient output - Worsening exhaust gas emissions - Engine stops in some cases	Key switch turn OFF

# Handling Instructions

No.	DTC name Text 1	Corrective action Text 2	ISO 14229 P-Code	J1939-73		Detection item	Remark	Behavior During Malfunction	Recovery from error
				SPN	FMI				
5	Fuel leak (in high pressured fuel system)	Stop ENG See Service Manual	P0093	1239	1	consumption is found)	To minimize PM emission to DPF	- Insufficient output - Worsening exhaust gas emissions - Engine stops in some cases	Key switch turn OFF
6	Intake air temp. error: Low	See Service Manual	P0112	172	4	Ground short circuit of sensor or harness		- White smoke increases at low temperature	Diagnostic counter = zero
7	Intake air temp. error: High	See Service Manual	P0113	172	3	Open circuit or +B short circuit of sensor or harness		- White smoke increases at low temperature	Diag counter = zero
8	Coolant temperature sensor: Low	See Service Manual	P0117	110	4	Ground short circuit of sensor or harness		- White smoke increases at low temperature - Insufficient output - Worsening exhaust gas emissions	Key switch turn OFF
9	Coolant temperature sensor: High	See Service Manual	P0118	110	3	Open circuit or +B short circuit of sensor or harness		- White smoke increases at low temperature - Insufficient output - Worsening exhaust gas emissions	Key switch turn OFF
10	Rail pressure sensor: Low	Stop ENG See Service Manual	P0192	157	4	Ground short circuit of sensor or harness Failure of sensor	To minimize PM emission to DPF	- Insufficient output - Worsening exhaust gas emissions - Engine running noise increases - White smoke increases - Engine stops	Key switch turn OFF

# Handling Instructions

No.	DTC name Text 1	Corrective action Text 2	ISO 14229 P-Code	J1939-73		Detection item	Remark	Behavior During Malfunction	Recovery from error
				SPN	FMI				
11	Rail pressure sensor: High	Stop ENG See Service Manual	P0193	157	3	Open circuit or +B short circuit of sensor or harness Failure of sensor	To minimize PM emission to DPF	- Insufficient output - Worsening exhaust gas emissions - Engine running noise increases - White smoke increases - Engine stops	Key switch turn OFF
12	Injector charge voltage: High	Stop ENG See Service Manual	P0200	523535	0	Injector charge voltage: High		- Insufficient output - Worsening exhaust gas emission - Engine stops	Key switch turn OFF
13	Open circuit of harness or coil in 1st cylinder injector	See Service Manual	P0201	651	3	Open circuit of harness Open circuit of injector coil	To minimize PM emission to DPF Injectors which have no error are operated	- Insufficient output - Engine vibration increases - Worsening exhaust gas emissions	Key switch turn OFF
14	Open circuit of harness or coil in 3rd cylinder injector	See Service Manual	P0202	653	3	Open circuit of harness Open circuit of injector coil	To minimize PM emission to DPF Injectors which have no error are operated	- Insufficient output - Engine vibration increases - Worsening exhaust gas emissions	Key switch turn OFF
15	Open circuit of harness or coil in 4th cylinder injector	See Service Manual	P0203	654	3	Open circuit of harness Open circuit of injector coil	To minimize PM emission to DPF Injectors which have no error are operated	- Insufficient output - Engine vibration increases - Worsening exhaust gas emissions	Key switch turn OFF
16	Open circuit of harness or coil in 2nd cylinder injector	See Service Manual	P0204	652	3	Open circuit of harness Open circuit of injector coil	To minimize PM emission to DPF Injectors which have no error are operated	- Insufficient output - Engine vibration increases - Worsening exhaust gas emissions	Key switch turn OFF
17	Engine overheat	Stop mowing!!	P0217	110	0	Overheat of engine coolant temperature		- Insufficient output - Overheat	Diagnostic counter = zero

# Handling Instructions

No.	DTC name Text 1	Corrective action Text 2	ISO 14229 P-Code	J1939-73		Detection item	Remark	Behavior During Malfunction	Recovery from error
				SPN	FMI				
18	Engine overrun	See Service Manual	P0219	190	0	Engine speed exceeds threshold speed		- Overrun	Diagnostic counter = zero
19	Boost pressure sensor: Low	See Service Manual	P0237	102	4	Ground short circuit of sensor or harness Failure of sensor	Default value is set in consideration with high altitude usage	- Insufficient output	Key switch turn OFF
20	Boost pressure sensor: High	See Service Manual	P0238	102	3	Open circuit or +B short circuit of sensor or harness Failure of sensor	Default value is set in consideration with high altitude usage	- Insufficient output	Key switch turn OFF
21	No input of NE sensor (Crank position sensor) pulse	See Service Manual	P0335	636	8	Open circuit or short circuit of sensor or harness Failure of sensor		(Running only with G signal) - Faulty starting - Engine Vibration increases slightly - Insufficient output	Key switch turn OFF
22	NE sensor (Crank position sensor) pulse number error	See Service Manual	P0336	636	2	Open circuit or short circuit of sensor or harness Failure of sensor		(Running only with G signal) - Faulty starting - Engine Vibration increases slightly - Insufficient output	Key switch turn OFF
23	No input of G sensor (Camshaft position sensor) pulse	See Service Manual	P0340	723	8	Open circuit or short circuit of sensor or harness Failure of sensor		(Invalid G signal) - Engine hesitates at start-up	Diagnostic counter = zero
24	G-sensor (Camshaft position sensor) pulse number error	See Service Manual	P0341	723	2	Open circuit or short circuit of sensor or harness Failure of sensor		(Invalid G signal) - Engine hesitates at start-up	Diagnostic counter = zero
25	Open circuit of glow relay driving circuit	See Service Manual	P0380	676	5	Open circuit of air glow relay		(At low temperature) - Faulty starting - White smoke increases	Key switch turn OFF
26	+B short of glow relay driving circuit	See Service Manual	P0380	523544	3	+B short of glow relay driving circuit		(At low temperature) - Faulty starting - White smoke increases	Key switch turn OFF

# Handling Instructions

No.	DTC name Text 1	Corrective action Text 2	ISO 14229 P-Code	J1939-73		Detection item	Remark	Behavior During Malfunction	Recovery from error
				SPN	FMI				
27	Ground short of glow relay driving circuit	See Service Manual	P0380	523544	4	Ground short of glow relay driving circuit		(At low temperature) - Faulty starting - White smoke increases	Key switch turn OFF
28	Glow heater relay driving circuit overheat	See Service Manual	P0381	676	0	Overheat of glow plug driving circuit		(At low temperature) - Faulty starting - White smoke increases	Key switch turn OFF
29	Oil pressure error	Stop ENG See Service Manual	P0524	100	1	Oil pressure switch		- Engine stops	Key switch turn OFF
30	Battery voltage: Low	See Service Manual	P0562	168	4	Open circuit, short circuit or damage of harness Failure of battery		- Faulty starting - Insufficient output - Worsening exhaust gas emissions - Engine stops in some cases	Diagnostic counter = zero
31	Battery voltage: High	See Service Manual	P0563	168	3	Open circuit, short circuit or damage of harness Failure of battery		- Faulty starting - Insufficient output - Worsening exhaust gas emissions	Key switch turn OFF
32	QR (IQA) data error	Contact dealer	P0602	523538	2	QR data read error	To cover each injector dispersion	- Insufficient output	Diagnostic counter = zero Key switch turn OFF
33	No QR (IQA) data	Contact dealer	P0602	523538	7	QR data is unwritten		- Insufficient output	Diagnostic counter = zero Key switch turn OFF
34	ECU FLASH ROM error	Stop ENG See Service Manual	P0605	628	2	FLASH ROM error		- Engine stops	Key switch turn OFF
35	ECU CPU (Main IC) error	Stop ENG See Service Manual	P0606	1077	2	Failure of CPU and/or IC		- Engine stops	Key switch turn OFF
36	ECU CPU (Monitoring IC) error	Stop ENG See Service Manual	P0606	523527	2	Failure of monitoring IC of CPU		- Engine stops	Key switch turn OFF

# Handling Instructions

No.	DTC name Text 1	Corrective action Text 2	ISO 14229 P-Code	J1939-73		Detection item	Remark	Behavior During Malfunction	Recovery from error
				SPN	FMI				
37	Injector charge voltage: Low	Stop ENG See Service Manual	P0611	523525	1	Injector charge voltage: Low Failure of charge circuit of ECU		- Insufficient output - Worsening exhaust gas emissions - Engine stops	Key switch turn OFF
38	Open circuit of SCV (MPROP)	Stop ENG See Service Manual	P0627	1347	5	Open circuit of SCV (MPROP)		- Insufficient output - Worsening exhaust gas emissions	Key switch turn OFF
39	SCV (MPROP) drive system error	Stop ENG See Service Manual	P0628	1347	4	Ground short circuit of SCV (MPROP)		- Insufficient output - Worsening exhaust gas emissions	Key switch turn OFF
40	+B short circuit of SCV (MPROP)	See Service Manual	P0629	1347	3	+B short circuit of SCV (MPROP)		- Insufficient output - Worsening exhaust gas emissions	Key switch turn OFF
41	Injector drive IC error or Open circuit	Stop ENG See Service Manual	P062B	1077	12	Injector drive IC error or Open circuit of No.1 & 4 cylinder injector or Open circuit of No.2 & 3 cylinder injector		- Engine stops	Key switch turn OFF
42	Internal injector drive circuit short	Stop ENG See Service Manual	P062D	523605	6	Short circuit in Injector driver IC		- Insufficient output - Engine Vibration increases - Worsening exhaust gas emissions - Engine stops in some cases	Key switch turn OFF
43	Sensor supply voltage 1: Low	See Service Manual	P0642	3509	4	Sensor supply voltage 1 error or recognition error	Emission related	- Faulty starting - Insufficient output - Worsening exhaust gas emissions - Engine stops in some cases	Key switch turn OFF

# Handling Instructions

No.	DTC name Text 1	Corrective action Text 2	ISO 14229 P-Code	J1939-73		Detection item	Remark	Behavior During Malfunction	Recovery from error
				SPN	FMI				
44	Sensor supply voltage 1: High	See Service Manual	P0643	3509	3	Sensor supply voltage 1 error or recognition error	Emission related	- Faulty starting - Insufficient output - Worsening exhaust gas emissions - Engine stops in some cases	Key switch turn OFF
45	Sensor supply voltage 2: Low	See Service Manual	P0652	3510	4	Sensor supply voltage 2 error or recognition error	Emission related	- Faulty starting - Insufficient output - Worsening exhaust gas emissions	Key switch turn OFF
46	Sensor supply voltage 2: High	See Service Manual	P0653	3510	3	Sensor supply voltage 2 error or recognition error	Emission related	- Faulty starting - Insufficient output - Worsening exhaust gas emissions	Key switch turn OFF
47	Sensor supply voltage 3: Low	See Service Manual	P0662	3511	4	Sensor supply voltage 3 error or recognition error		- Faulty starting	Key switch turn OFF
48	Sensor supply voltage 3: High	See Service Manual	P0663	3511	3	Sensor supply voltage 3 error or recognition error		- Faulty starting	Key switch turn OFF
49	Main relay is locked in closed position	See Service Manual	P0687	1485	2	Failure of main relay		- Battery goes dead	Key switch turn OFF
50	Ground short of Starter relay driving circuit	See Service Manual	P081A	677	4	Ground short of Starter relay driving circuit		- Faulty starting	Key switch turn OFF
51	Accelerator position sensor 1: Low	See Service Manual	P2122	91	4	Ground short circuit or open circuit of sensor or harness		- Insufficient output	Diagnostic counter = zero
52	Accelerator position sensor 1: High	See Service Manual	P2123	91	3	Battery short circuit out of sensor or harness		- Insufficient output	Diagnostic counter = zero
53	Accelerator position sensor 2: Low	See Service Manual	P2127	29	4	Ground short circuit or open circuit of sensor or harness		- Insufficient output	Diagnostic counter = zero
54	Accelerator position sensor 2: High	See Service Manual	P2128	29	3	Battery short circuit out of sensor or harness		- Insufficient output	Diagnostic counter = zero



# Handling Instructions

No.	DTC name Text 1	Corrective action Text 2	ISO 14229 P-Code	J1939-73		Detection item	Remark	Behavior During Malfunction	Recovery from error
				SPN	FMI				
55	Accelerator Position Sensor Error (CAN)	See Service Manual	P2131	523543	2	Accelerator position sensor signal error (sensor or harness open circuit, ground short circuit etc.)		- Insufficient output	Diagnostic counter = zero (CAN signal recovers)
57	No. 1 & 4 cylinder injector short to +B or GND	Stop ENG See Service Manual	P2148	523523	3	Wiring harness short to +B or Wiring harness short to ground	To minimize PM emission to DPF Injectors which have no error are operated	- Insufficient output - Engine Vibration increases - Worsening exhaust gas emissions - Engine stops in some cases	Key switch turn OFF
59	No. 2 & 3 cylinder injector short to +B or GND	Stop ENG See Service Manual	P2151	523524	3	Wiring harness short to +B or Wiring harness short to ground	To minimize PM emission to DPF Injectors which have no error are operated	- Insufficient output - Engine Vibration increases - Worsening exhaust gas emissions - Engine stops in some cases	Key switch turn OFF
60	Barometric pressure sensor error (Low side)	See Service Manual	P2228	108	4	Sensor or ECU internal circuit short to ground	Default value is set in consideration with high altitude usage	- Insufficient output	Diagnostic counter = zero
61	Barometric pressure sensor error (High side)	See Service Manual	P2229	108	3	Sensor or ECU internal circuit short to +B	Default value is set in consideration with high altitude usage	- Insufficient output	Diagnostic counter = zero
62	Pressure limiter not open	See Service Manual	P2293	679	7	Rail pressure value is sticking or too low engine power not to open PL valve forcibility		- Engine stops	Key switch turn OFF
63	CAN1 Bus off	See Service Manual	U0077	523604	2	CAN1 +B or GND short circuit or high traffic error		- Insufficient output - Transmitted CAN data are invalid	Key switch turn OFF

# Handling Instructions

No.	DTC name Text 1	Corrective action Text 2	ISO 14229 P-Code	J1939-73		Detection item	Remark	Behavior During Malfunction	Recovery from error
				SPN	FMI				
64	CAN2 Bus off	See Service Manual	U0075	523547	2	CAN2 +B or GND short circuit or high traffic error		- Insufficient output - Transmitted CAN data are invalid	Key switch turn OFF
65	CAN-KBT Frame error	See Service Manual	U0081	523548	2	CAN-KBT original frame open circuit error		- Insufficient output	Key switch turn OFF
66	Intake air temp. built-in MAF sensor: Low	See Service Manual	P0072	171	4	Ground short circuit of sensor or harness		None	Diagnostic counter = zero
67	Intake air temp. built-in MAF sensor: High	See Service Manual	P0073	171	3	Open circuit or +B short circuit of sensor or harness		None	Diagnostic counter = zero
68	Intake air volume: Low	See Service Manual	P0101	132	1	Engine inlet air mass flow rate lacking (Disconnect turbo blower intake hose)		- Insufficient output	Key switch turn OFF
70	MAF sensor: High	See Service Manual	P0103	132	3	+B short circuit of sensor or harness	Engine is not stopped forcibly by ECU However KUBOTA strongly recommends operator to stop engine as soon as possible	- Insufficient output - Worsening exhaust gas emissions	Key switch turn OFF
71	EGR actuator open circuit	See Service Manual	P0403	523574	3	EGR actuator open circuit		- Insufficient output - Worsening exhaust gas performance	Key switch turn OFF
72	EGR actuator coil short	See Service Manual	P0404	523574	4	EGR actuator coil short		- Insufficient output - Worsening exhaust gas emissions	Key switch turn OFF
73	EGR position sensor failure	See Service Manual	P0409	523572	4	EGR position sensor failure		- Insufficient output - Worsening exhaust gas emissions	Key switch turn OFF
74	Exhaust gas temperature sensor 1: Low	See Service Manual	P0543	3242	4	Ground short circuit of sensor or harness		None	Key switch turn OFF

# Handling Instructions

No.	DTC name Text 1	Corrective action Text 2	ISO 14229 P-Code	J1939-73		Detection item	Remark	Behavior During Malfunction	Recovery from error
				SPN	FMI				
75	Exhaust gas temperature sensor 1: High	See Service Manual	P0544	3242	3	Open circuit or +B short circuit of sensor or harness		None	Key switch turn OFF
76	Exhaust gas temperature sensor 0: Low	See Service Manual	P0546	4765	4	Ground short circuit of sensor or harness		None	Key switch turn OFF
77	Exhaust gas temperature sensor 0: High	See Service Manual	P0547	4765	3	Open circuit or +B short circuit of sensor or harness		None	Key switch turn OFF
78	EEPROM check sum error	See Service Manual	P1990	523700	13	KBT-EEPROM check sum error		None	Key switch turn OFF
79	EEPROM check sum error (DST1)	See Service Manual	P1991	523701	13	DST1-EEPROM check sum error		None	Key switch turn OFF
80	EEPROM check sum error (DST2)	See Service Manual	P1992	523702	13	DST2-EEPROM check sum error		None	Key switch turn OFF
81	Intake throttle feedback error	See Service Manual	P2108	523580	2	Intake throttle feedback error		None	Key switch turn OFF
82	Accelerator position sensor correlation error	See Service Manual	P2135	91	2	Deviation from designed correlation in two sensors		- Insufficient output	Diagnostic counter = zero
83	EGR actuator valve stuck	See Service Manual	P2413	523575	7	EGR actuator valve stuck		- Insufficient output - Worsening exhaust gas performance	Key switch turn OFF
84	EGR (DC motor) overheat	See Service Manual	P2414	523576	2	EGR (DC motor) overheat		- Insufficient output - Worsening exhaust gas emissions	Key switch turn OFF
85	EGR (DC motor) temp. sensor failure	See Service Manual	P2415	523577	2	EGR (DC motor) temp. sensor failure		- Insufficient output - Worsening exhaust gas emissions	Key switch turn OFF
86	Exhaust gas temperature sensor 2: Low	See Service Manual	P242C	3246	4	Ground short circuit of sensor or harness		None	Key switch turn OFF
87	Exhaust gas temperature sensor 2: High	See Service Manual	P242D	3246	3	Open circuit or +B short circuit of sensor or harness		None	Key switch turn OFF

# Handling Instructions

No.	DTC name Text 1	Corrective action Text 2	ISO 14229 P-Code	J1939-73		Detection item	Remark	Behavior During Malfunction	Recovery from error
				SPN	FMI				
88	Differential pressure sensor 1: Low	See Service Manual	P2454	3251	4	Ground short circuit of sensor or harness		None	Key switch turn OFF
90	Intake throttle lift sensor: Low	See Service Manual	P2621	523582	4	Intake throttle lift sensor: Low		None	Key switch turn OFF
91	Intake throttle lift sensor: High	See Service Manual	P2622	523582	3	Intake throttle lift sensor: High		None	Key switch turn OFF
92	Emission deterioration	See Service Manual	P3001	3252	0	DOC is heated up due to unburned fuel	To minimize PM emission to DPF	- Insufficient output	Key switch turn OFF
93	Emergency Exhaust gas temperature sensor 0: High	Stop ENG See Service Manual	P3002	4765	0	DOC inlet temp. (T0): High	<ul style="list-style-type: none"> <li>In case engine ECU is not involved to drive starter, starter activation should be inhibited by other way until exhaust temp. reduces down to 300 degC (572 degF)</li> </ul>	<ul style="list-style-type: none"> <li>Engine stops</li> <li>Inhibited cranking until down to 300 degC (572 degF)</li> </ul>	<ul style="list-style-type: none"> <li>Engine stops</li> <li>Inhibited cranking until down to 300 degC (572 degF)</li> </ul>
94	Emergency Exhaust gas temperature sensor 1: High	Stop ENG See Service Manual	P3003	3242	0	DPF inlet temp. (T1): High	<ul style="list-style-type: none"> <li>In case engine ECU is not involved to drive starter, starter activation should be inhibited by other way until exhaust temp. reduces down to 300 degC (572 degF)</li> </ul>	<ul style="list-style-type: none"> <li>Engine stops</li> <li>Inhibited cranking until down to 300 degC (572 degF)</li> </ul>	Under 300 degC & Key switch turn OFF
95	Emergency Exhaust gas temperature sensor 2: High	Stop ENG See Service Manual	P3004	3246	0	DPF outlet temp. (T2): High	<ul style="list-style-type: none"> <li>In case engine ECU is not involved to drive starter, starter activation should be inhibited by other way until exhaust temp. reduces down to 300 degC (572 degF)</li> </ul>	<ul style="list-style-type: none"> <li>Engine stops</li> <li>Inhibited cranking until down to 300 degC (572 degF)</li> </ul>	Under 300 degC & Key switch turn OFF
96	Excessive PM3	Start DPF Parked Regeneration immediately	P3006	3701	15	PM accumulation level 3	To minimize PM emission	- Insufficient output	Diagnostic counter = zero

# Handling Instructions

No.	DTC name Text 1	Corrective action Text 2	ISO 14229 P-Code	J1939-73		Detection item	Remark	Behavior During Malfunction	Recovery from error
				SPN	FMI				
97	Excessive PM4	Stop engine!! Contact dealer immediately	P3007	3701	16	PM accumulation level 4	To minimize PM emission	- Insufficient output	Diagnostic counter = zero
98	Excessive PM5	Stop engine!! Contact dealer immediately	P3008	3701	0	PM accumulation level 5	To minimize PM emission Engine is not stopped forcibly by ECU However KUBOTA strongly recommends operator to stop engine as soon as possible	- Insufficient output	Key switch turn OFF (Reset by Service tool)
99	Boost pressure: Low	See Service Manual	P3011	132	15	Disconnect the hose between the turbo blower out and intake flange Boost pressure sensor error	Engine power is restricted by boost pressure signal accordingly To minimize PM emission to DPF	- Insufficient output	Key switch turn OFF
100	Low coolant temp. in parked regeneration	See Service Manual	P3012	523589	17	During regeneration mode, Engine warm-up condition is not satisfied (coolant temp. is low)		None	Diagnostic counter = zero (Leaving from Parked active regeneration status)
101	Parked regeneration time out	See Service Manual	P3013	523590	16	Time out error: regeneration incomplete due to low temperature of DPF		None	Diagnostic counter = zero (Leaving from Parked active regeneration status)
102	All exhaust temp. sensor failure	See Service Manual	P3018	523599	0	All exhaust temp. sensor failure simultaneously		None	Diagnostic counter = zero
103	High exhaust gas temp. after emergency high temp. DTC	Stop ENG See Service Manual	P3023	523601	0	Exhaust gas temperature sensor 0, 1, 2 output		None	Diagnostic counter = zero
104	High frequency of regeneration	See Service Manual	P3024	523602	0	Time interval from the end time to the start time of the regeneration		- Worsening exhaust gas emissions (NOx)	Key switch turn OFF (Reset by Service tool)

# Handling Instructions

No.	DTC name Text 1	Corrective action Text 2	ISO 14229 P-Code	J1939-73		Detection item	Remark	Behavior During Malfunction	Recovery from error
				SPN	FMI				
105	Over heat pre- caution	See Service Manual	P3025	523603	15	Coolant temp.		- Worsening exhaust gas emissions (NOx)	Diagnostic counter = zero
106	No communication with EGR	See Service Manual	U0076	523578	2	No communication with EGR		- Insufficient output - Worsening exhaust gas emissions	Key switch turn OFF
107	CAN CCVS (Parking SW and Vehicle speed) frame error	See Service Manual	U0082	523591	2	CAN_CCVS communication stopping		None	Key switch turn OFF
108	CAN CM1 (Regen SW) frame error	See Service Manual	U0083	523592	2	CAN_CM1 communication stopping		None	Key switch turn OFF
109	CAN DDC1 (Transmission) frame error	See Service Manual	U0084	523593	2	CAN_DDC1 communication stopping		None	Key switch turn OFF
110	CAN ETC2 (Neutral SW) frame error	See Service Manual	U0085	523594	2	CAN_ETC2 communication stopping		None	Key switch turn OFF
111	CAN ETC5 (Neutral SW) frame error	See Service Manual	U0086	523595	2	CAN_ETC5 communication stopping		None	Key switch turn OFF
112	CAN TSC1 frame error	See Service Manual	U0087	523596	2	CAN_TSC1 communication stopping		None	Diagnostic counter = zero
113	CAN EBC1 frame error	See Service Manual	U0089	523598	2	CAN_EBC1 communication stopping		None	Diagnostic counter = zero
114	FUEL LEVEL LOW	Refuel	None	96	17	Remaining fuel volume at specified value or less (factory default setting=10%) Can be adjusted between 10% and 80%		None	Supply fuel until remaining fuel volume reaches the specified value or above
115	Open Circuit of Differential Pressure Sensor and Exhaust Gas Temp. Sensor	See Service Manual	P1A28	3936	7	Removal of DPF	PCD	-	-

# Handling Instructions

No.	DTC name Text 1	Corrective action Text 2	ISO 14229 P-Code	J1939-73		Detection item	Remark	Behavior During Malfunction	Recovery from error
				SPN	FMI				
116	Loss of DPF Function	See Service Manual	P3015	3936	2	Loss of function of DPF	PCD	-	-
117	Open Circuit of Differential pressure sensor	See Service Manual	P2455	3251	3	Open circuit or +B short circuit of sensor or harness	PCD	None	Diagnostic counter = zero
118	Open Circuit of ENG CAN Line	See Service Manual	U0076	523578	2	No communication with EGR	NCD	None	Diagnostic counter = zero
119	Open Circuit of MAF Sensor	See Service Manual	P0102	132	4	Open circuit or ground short circuit of sensor or harness	Engine is not stopped forcibly by ECU However KUBOTA strongly recommends operator to stop engine as soon as possible	- Insufficient output - Worsening exhaust gas emissions	Diagnostic counter = zero

# Handling Instructions

## Engine Configuration

This function is not supported.

### 1-Up Display Setup

With "SETUP 1-UP DISPLAY", the displayed parameters can be reset to the factory defaults, or the monitor display of selected, necessary parameters can be set up. The following 3 items appear when "SETUP 1-UP DISPLAY" is selected.

- USE DEFAULTS
- CUSTOM SETUP
- AUTOMATIC SCAN

#### ■Use Defaults

With "USE DEFAULTS", the 1-up display parameters return to the factory defaults.

1. Press the menu key. After the main menu appears, use the arrow keys to highlight "SETUP 1-UP DISPLAY", and then press the Enter key.

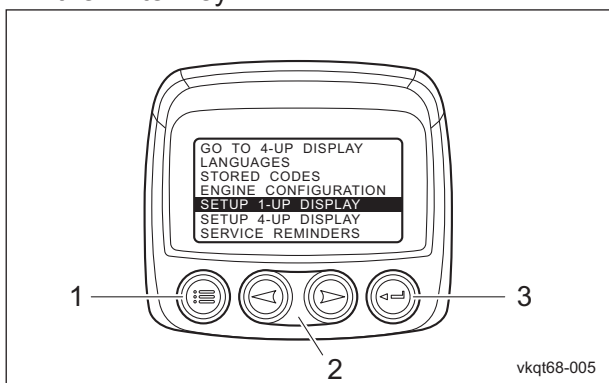

Use Defaults\_001

1	Menu key
2	Arrow keys
3	Enter key

2. Highlight "USE DEFAULTS", and then press the Enter key.

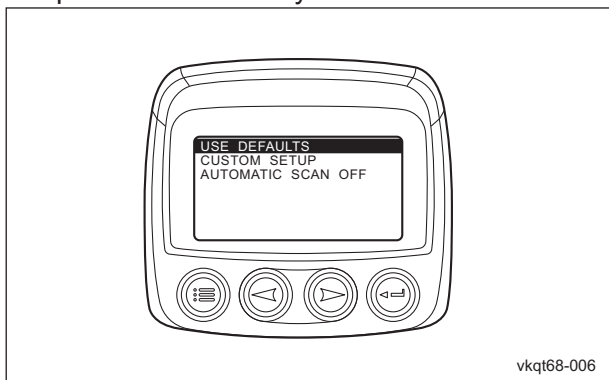

Use Defaults\_002

3. "RESTORED TO DEFAULTS" appears in the monitor display, and the parameters are reset to the factory defaults of the following 8 items.

- [1] ENGINE SPEED
- [2] ENGINE COOLANT TEMPERATURE
- [3] %SOOT
- [4] FUEL LEVEL
- [5] ENGINE OIL PRESSURE
- [6] MACHINE HOURS
- [7] BATTERY POTENTIAL
- [8] DPF STATUS

4. After the settings have been applied, pressing the menu key once returns to the main menu, and pressing the key again returns to the 1-up/4-up display screen.

#### ■Custom Setup

With "CUSTOM SETUP", the type and number of parameters as well as their display order can be specified.

1. Press the menu key. After the main menu appears, use the arrow keys to highlight "SETUP 1-UP DISPLAY", and then press the Enter key.

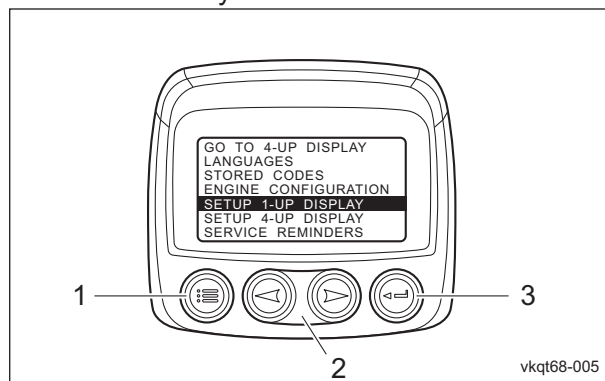

Custom Setup\_001

1	Menu key
2	Arrow keys
3	Enter key



# Handling Instructions

2. Highlight "CUSTOM SETUP", and then press the Enter key.  
The list of parameters appears.

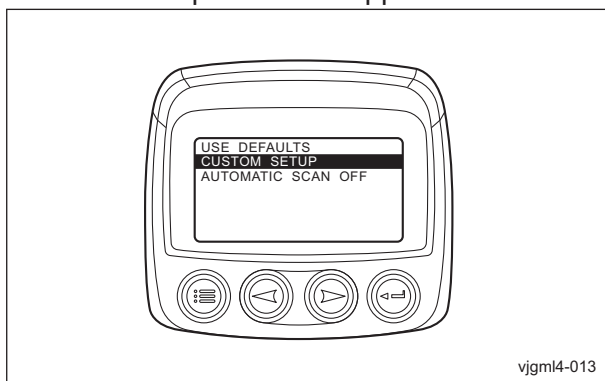

vjgml4-013

Custom Setup\_002

3. Change the parameters.

[1] To add a parameter

- a. Use the arrow keys to highlight the parameter to be added, and then press the Enter key.

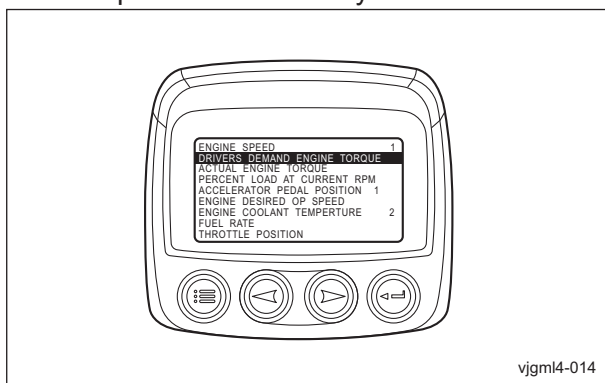

vjgml4-014

Custom Setup\_003

- b. A number appears at the right of the selected parameter. This number indicates the display order for the parameter

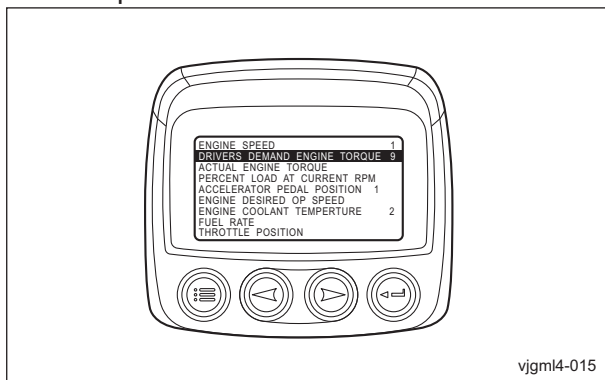

vjgml4-015

Custom Setup\_004

- [2] To deselect a parameter and remove it from the list of displayed parameters
- a. Highlight the parameter, and then press the Enter key.

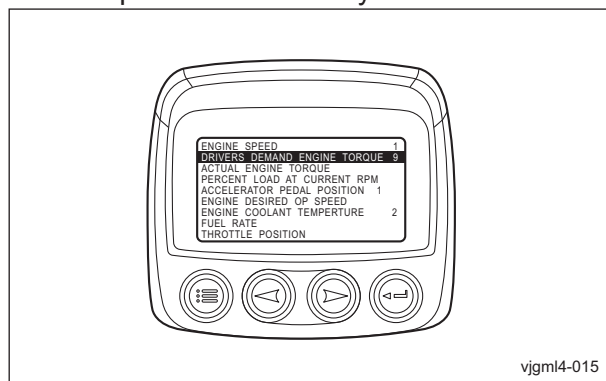

vjgml4-015

Custom Setup\_005

- b. Check that the number at the right of the parameter disappeared.

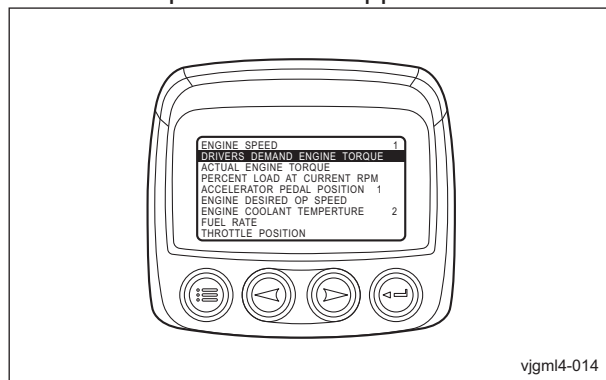

vjgml4-014

Custom Setup\_006

4. After the settings have been applied, pressing the menu key once returns to the main menu, and pressing the key again returns to the 1-up/4-up display screen.

# Handling Instructions

## Automatic Scan

With "AUTOMATIC SCAN", the 1-up display can be set to automatically scroll through the selected parameters one by one.

1. Press the menu key.

After the main menu appears, use the arrow keys to highlight "SETUP 1-UP DISPLAY", and then press the Enter key.

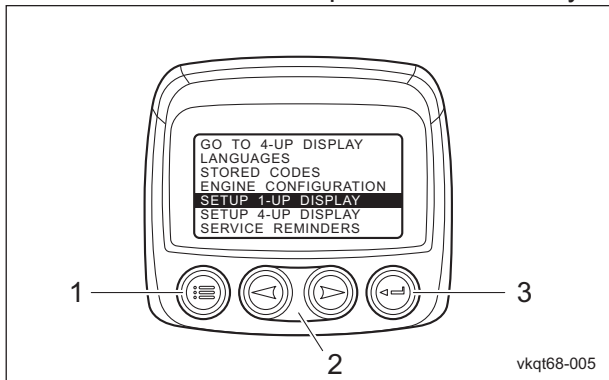

Automatic Scan\_001

1	Menu key
2	Arrow keys
3	Enter key

2. When "AUTOMATIC SCAN ON" appears, the parameters are scrolled automatically. For manual scrolling, highlight "AUTOMATIC SCAN ON", and then press the Enter key.

It turns into "AUTOMATIC SCAN OFF" and the parameters will be scrolled manually.

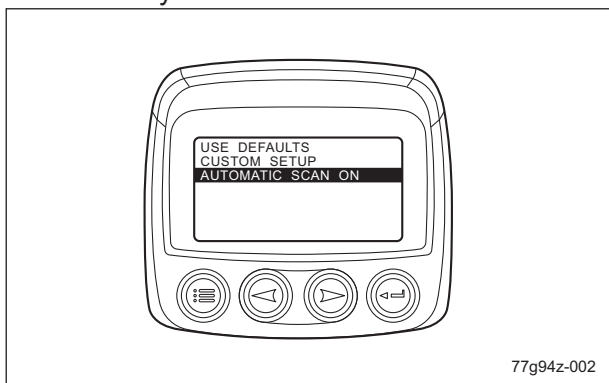

Automatic Scan\_002

3. After the settings have been applied, pressing the menu key once returns to the main menu, and pressing the key again returns to the 1-up/4-up display screen.

Note:

When the parameters are scrolled automatically, press the Enter key once to pause scrolling.

When scrolling is paused, press the Enter key once to restart scrolling.

## 4-Up Display Setup

With "SETUP 4-UP DISPLAY", the displayed parameters can be reset to the factory defaults, or the monitor display of selected, necessary parameters can be set up.

The following 2 items appear when "SETUP 4-UP DISPLAY" is selected.

- USE DEFAULTS
- CUSTOM SETUP

## Use Defaults

With "USE DEFAULTS", the 4-up display parameters return to the factory defaults.

1. Press the menu key.

After the main menu appears, use the arrow keys to highlight "SETUP 4-UP DISPLAY", and then press the Enter key.

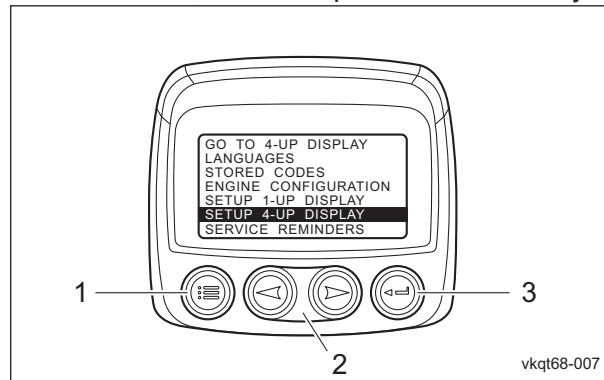

Use Defaults\_001

1	Menu key
2	Arrow keys
3	Enter key

# Handling Instructions

2. Highlight "USE DEFAULTS", and then press the Enter key.

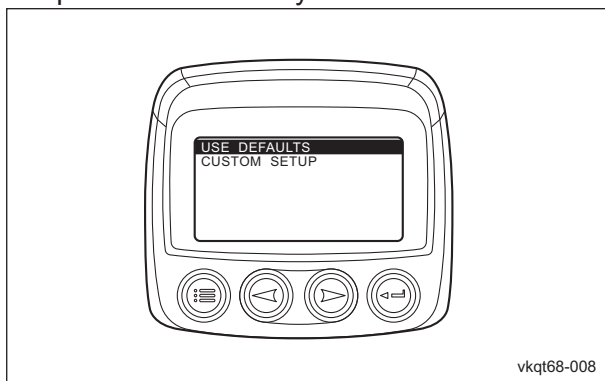

vkqt68-008

Use Defaults\_002

3. "RESTORED TO DEFAULTS" appears in the monitor display, and the parameters are reset to the factory defaults of the following 8 items.

- First page
  - [1] ENGINE SPEED
  - [2] ENGINE COOLANT TEMPERATURE
  - [3] %SOOT
  - [4] FUEL LEVEL
- Second page
  - [1] ENGINE OIL PRESSURE
  - [2] MACHINE HOURS
  - [3] BATTERY POTENTIAL
  - [4] DPF STATUS

4. After the settings have been applied, pressing the menu key once returns to the main menu, and pressing the key again returns to the 1-up/4-up display screen.

## ■ Custom Setup

With "CUSTOM SETUP", the type and number of parameters as well as their display order can be specified.

1. Press the menu key. After the main menu appears, use the arrow keys to highlight "SETUP 4-UP DISPLAY", and then press the Enter key.

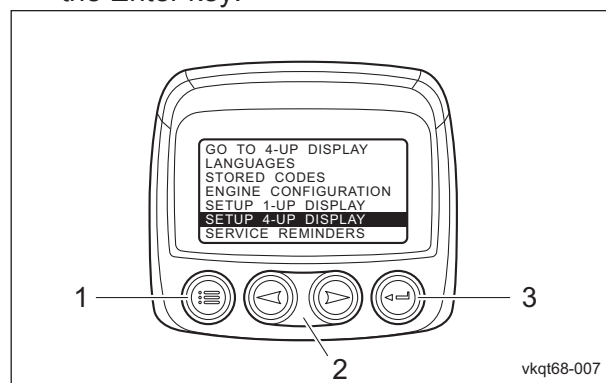

vkqt68-007

Custom Setup\_001

1	Menu key
2	Arrow keys
3	Enter key

2. Highlight "CUSTOM SETUP", and then press the Enter key.

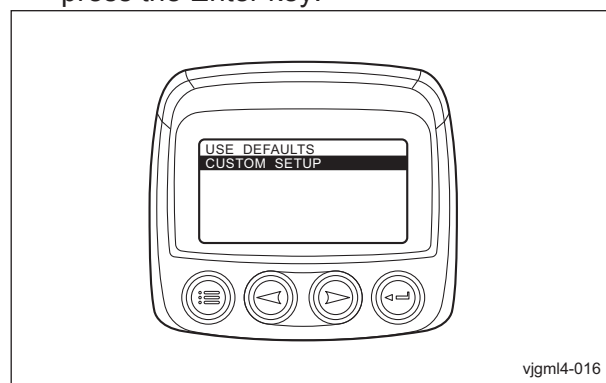

vjgml4-016

Custom Setup\_002

# Handling Instructions

3. Select the page.

[1] Check that the values for the four parameters are highlighted.

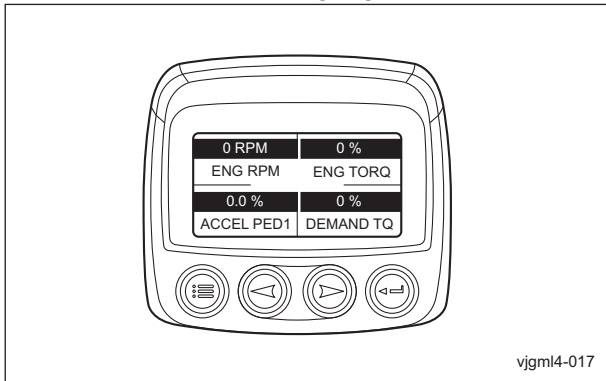

Custom Setup\_003

1	Parameter values
---	------------------

[2] Use the arrow keys to display the page to be changed, and then press the Enter key.

4. Change the parameters.

[1] Check that the value for one parameter is highlighted.

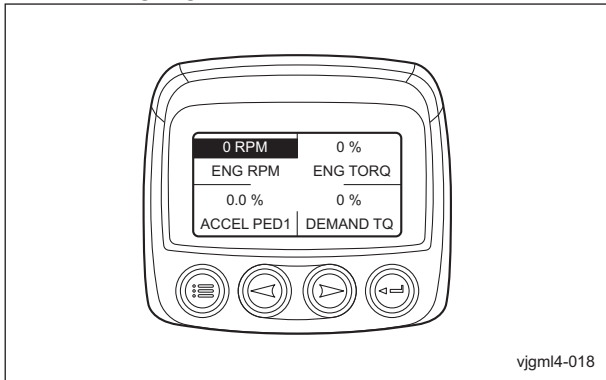

Custom Setup\_004

[2] Use the arrow keys to highlight the value of the parameter to be changed, and then press the Enter key.

[3] The parameters appear.

The number at the right of the parameter indicates the location in the 4-up display.

- 1=Upper left
- 2=Lower left
- 3=Upper right
- 4=Lower right

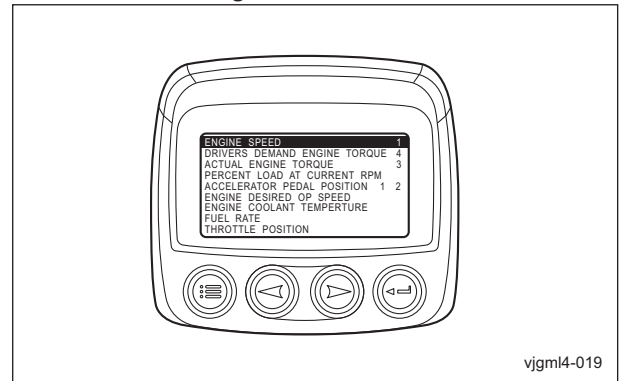

Custom Setup\_005

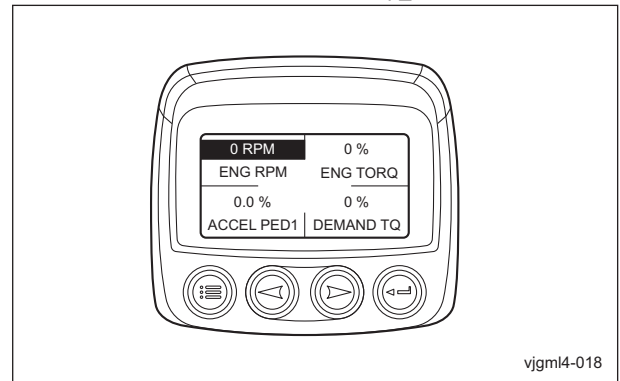

Custom Setup\_006

[4] To change to a different parameter  
 a. Use the arrow keys to highlight the parameter to be selected, and then press the Enter key.

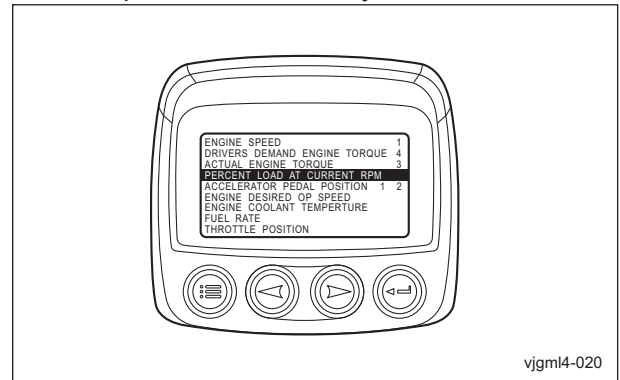

Custom Setup\_007

# Handling Instructions

- b. Check that a number appeared to the right of the selected parameter.

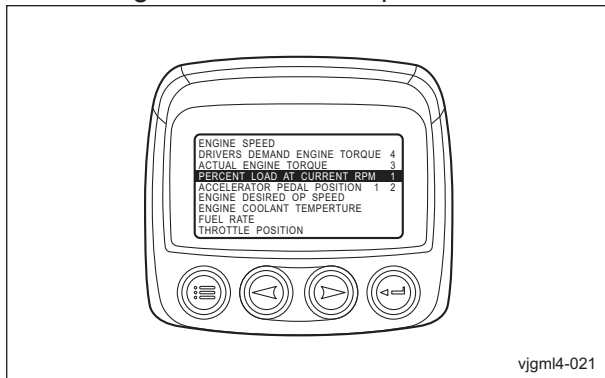

vjgml4-021

Custom Setup\_008

- c. Press the menu key and check that the parameter has changed.

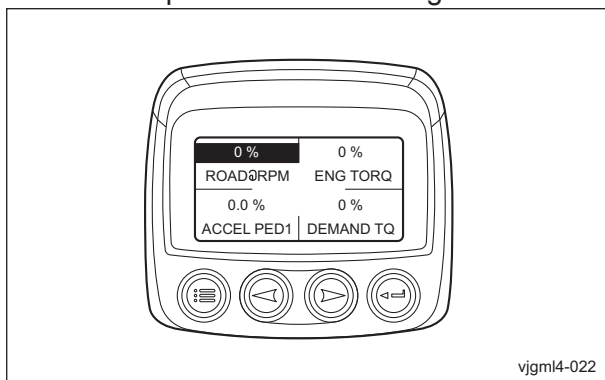

vjgml4-022

Custom Setup\_009

- [5] To deselect a parameter and remove it from the list of displayed parameters

- a. Highlight the parameter to be removed, and then press the Enter key.

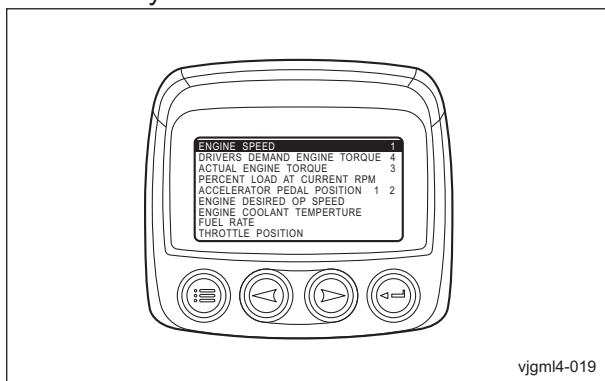

vjgml4-019

Custom Setup\_010

- b. Check that the number at the right of the parameter disappeared.

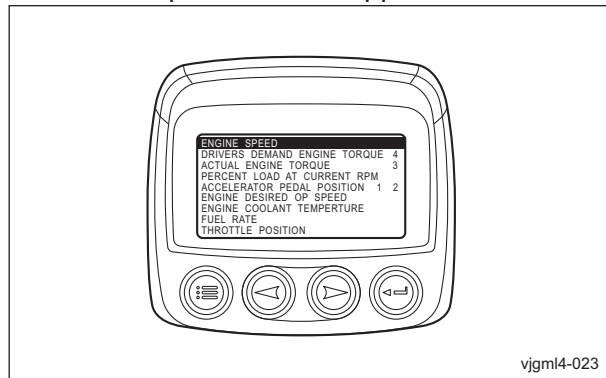

vjgml4-023

Custom Setup\_011

- c. Press the menu key and check that the parameter has changed to "EMPTY".

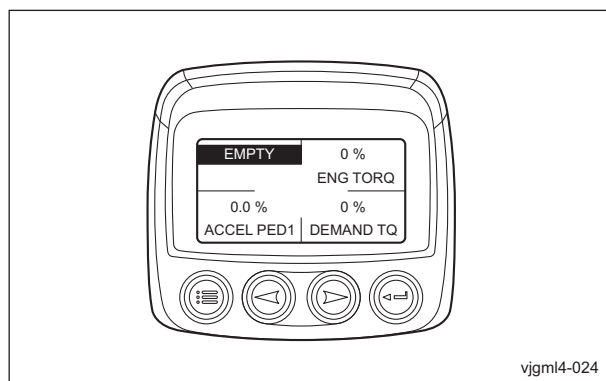

vjgml4-024

Custom Setup\_012

5. Pressing the menu key once returns to the display for selecting the page.

6. To change other parameters, repeat steps 3 to 5.

## Service Reminders

With "SERVICE REMINDERS", the notification of replacement time for the following 5 consumables can be specified.

- Engine oil
- Engine oil filter
- Hydraulic oil
- Hydraulic oil filter
- Air cleaner

The following 2 items appear when "SERVICE REMINDERS" is selected.

- RESET REMINDERS
- MODIFY REMINDERS

# Handling Instructions

## Reset Reminders

With "RESET REMINDER", displayed remaining time can be reset to the time specified with "MODIFY REMINDERS".

1. Press the menu key.

After the main menu appears, use the arrow keys to highlight "SERVICE REMINDERS", and then press the Enter key.

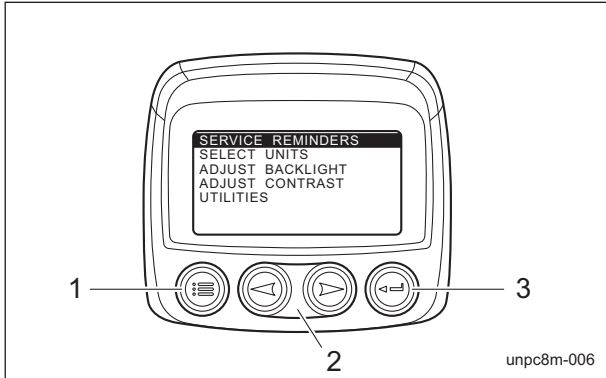

Reset Reminders\_001

1	Menu key
2	Arrow keys
3	Enter key

2. Highlight "RESET REMINDER", and then press the Enter key.

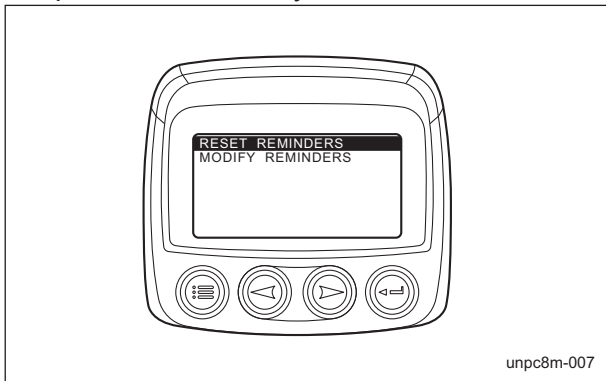

Reset Reminders\_002

3. Use the arrow keys to highlight the item to be changed, and then press the Enter key. A plus appears at the right of the currently selected items.

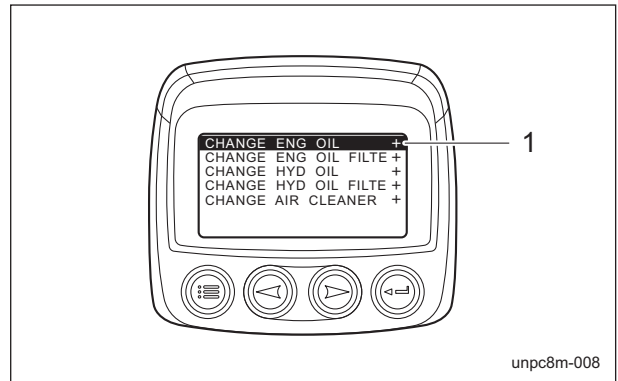

Reset Reminders\_003

1	Plus
---	------

4. The remaining time for the selected item appears.

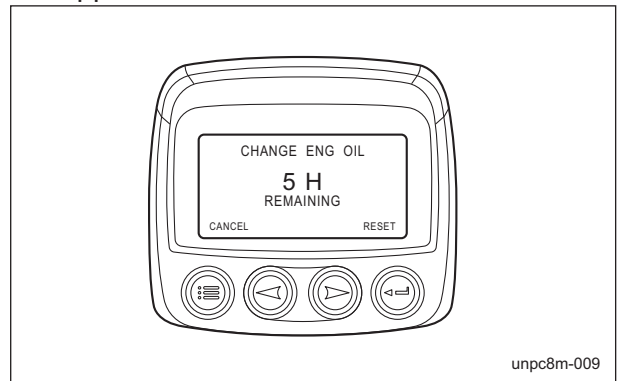

Reset Reminders\_004

[1] To reset the remaining time to the specified time, press the Enter key.

[2] "RESET SERVICE REMINDER?" appears.

To reset, press the Enter key.

To cancel resetting, press the menu key.

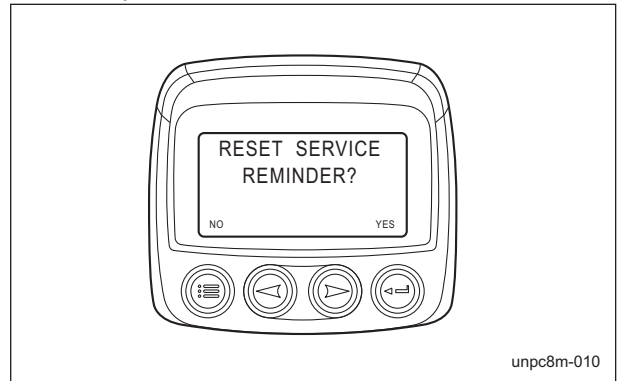

Reset Reminders\_005

5. The screen for selecting the item appears.

# Handling Instructions

## ■Modify Reminders

With "MODIFY REMINDERS", the replacement time period for consumables can be specified.

The factory default replacement time periods are the initial time periods.

Change the setting as necessary.

The replacement time period should be in accordance with the maintenance schedule.

Initial and regular time periods

	Initial time period	Regular time period
Engine oil	50 hrs.	400 hrs.
Engine oil filter	50 hrs.	400 hrs.
Hydraulic oil	100 hrs.	500 hrs.
Hydraulic oil filter	100 hrs.	500 hrs.
Air cleaner	600 hrs.	600 hrs.

1. Press the menu key.

After the main menu appears, use the arrow keys to highlight "SERVICE REMINDERS", and then press the Enter key.

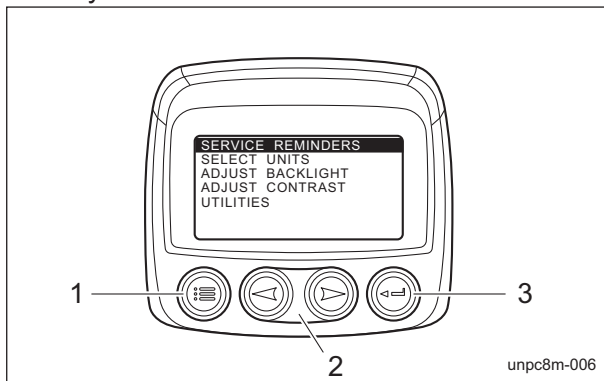

Modify Reminders\_001

1	Menu key
2	Arrow keys
3	Enter key

2. Highlight "MODIFY REMINDERS", and then press the Enter key.

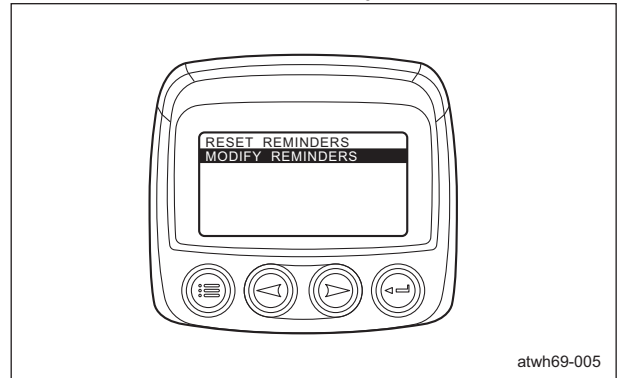

Modify Reminders\_002

3. Use the arrow keys to highlight the item to be changed, and then press the Enter key. A plus appears at the right of the currently specified items.

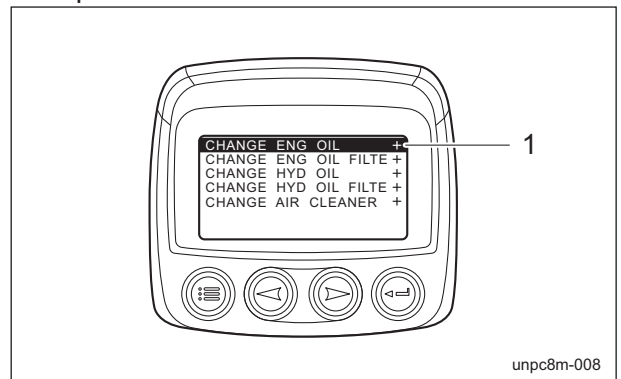

Modify Reminders\_003

1	Plus
---	------

4. The replacement time period for the selected item appears.

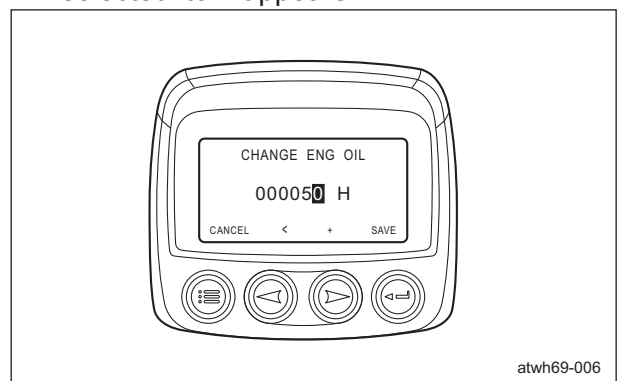

Modify Reminders\_004



# Handling Instructions

- Highlight the digit to be changed.  
Press the right arrow key to increase the number. Press the left arrow key to change the digit.

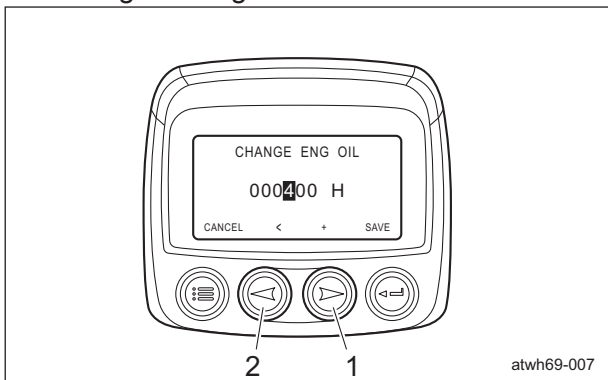

Modify Reminders\_005

1	Right arrow key
2	Left arrow key

- To save the specified time period, press the Enter key.
- "MODIFY SERVICE REMINDER?" appears.  
To save the changes, press the Enter key.  
To cancel the changes, press the menu key.

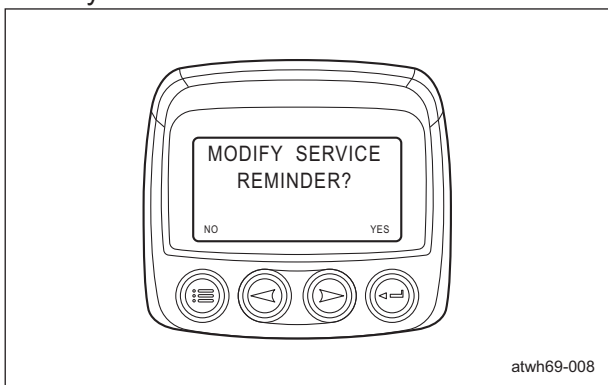

Modify Reminders\_006

- The display for selecting the item appears.

## Reminder Display

### Important

If a warning message appears, immediately stop operation, and then perform the replacement procedure.

- When the specified replacement time period for a consumable has passed, a warning message appears in the monitor display and the LED (yellow) lights up.

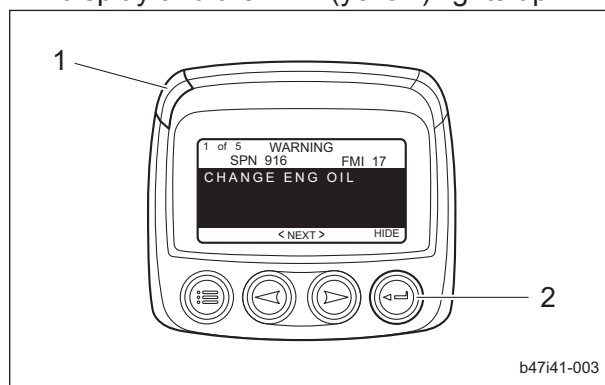

Reminder Display\_001

1	LED (yellow)
2	Enter key

- Pressing the Enter key changes the screen from the warning message to the parameter display.
- A warning mark appears in the upper-right corner of the monitor display.

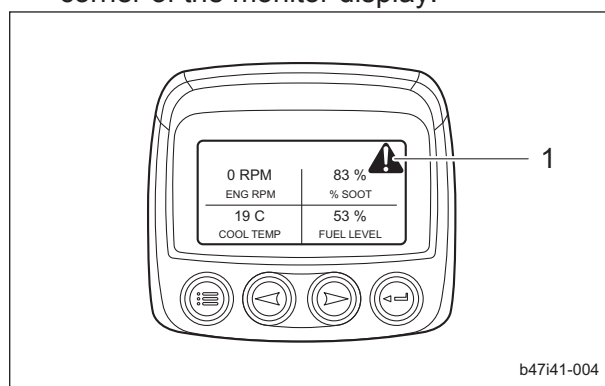

Reminder Display\_002

1	Warning mark
---	--------------

- Change the replacement time period of consumables with "RESET REMINDERS" or "MODIFY REMINDERS".  
When the replacement time period is changed, the warning message and mark disappear.



# Handling Instructions

## Select Units

With "SELECT UNITS", the units of parameter values can be set to any of the following three formats.

- ENGLISH
- METRIC KPA
- METRIC BAR

An asterisk appears at the right of the currently selected unit.

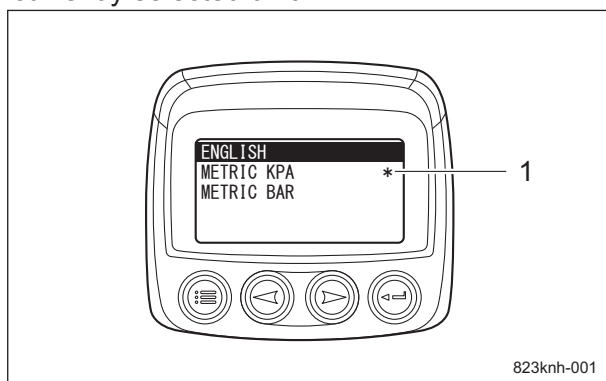

Select Units\_001

1	Asterisk
---	----------

Monitor display S	Units		
	ENGLISH	METRIC KPA	METRIC BAR
ENG RPM	RPM	RPM	RPM
DEMAND TQ	%	%	%
ENG TORQ	%	%	%
LOAD@RPM	%	%	%
ACCEL PED1	%	%	%
DES ENG SP	RPM	RPM	RPM
COOL TEMP	F	C	C
FUEL RATE	G/HR	L/HR	L/HR
THROTTLE	%	%	%
BST PRES	PSI	kPa	BAR
MANI TEMP	F	C	C
BAT VOLT	VDC	VDC	VDC
BARO PRES	PSI	kPa	BAR
AMB TEMP	F	C	C
AIR IN TP	F	C	C
FUEL USED	Gal	L	L
ENG HRS	H	H	H
OIL PRES	PSI	kPa	BAR
RAIL PRES	PSI	kPa	BAR
AIR RATE	Gal	L	L
DOC TEMP	F	C	C
EF IN T	F	C	C
DIFF PRES	PSI	kPa	BAR
EF OUT T	F	C	C
%SOOT	%	%	%
MACH HRS	H	H	H
FUEL LEVEL	%	%	%

### Note:

The factory default unit is "METRIC KPA".

# Handling Instructions

## Adjust Backlight

With "ADJUST BACKLIGHT", the brightness of the monitor display can be adjusted. Press the right arrow key to make the display brighter. Press the left arrow key to make the display darker.

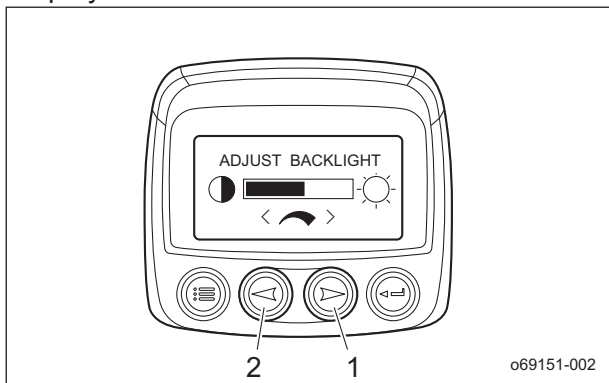

Adjust Backlight\_001

1	Right arrow key
2	Left arrow key

## Adjust Contrast

With "ADJUST CONTRAST", the contrast of the monitor display can be adjusted. Press the right arrow key to decrease the contrast. Press the left arrow key to increase the contrast.

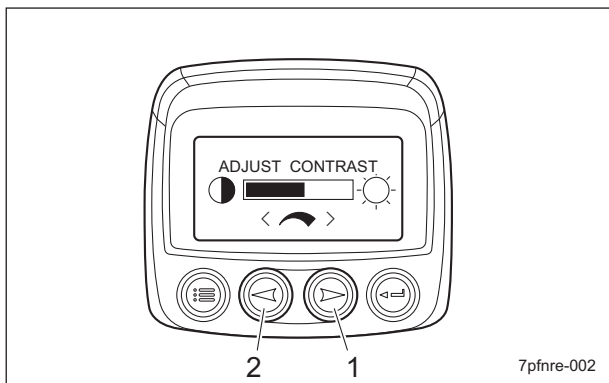

Adjust Contrast\_001

1	Right arrow key
2	Left arrow key

## Utilities

With "UTILITIES", the remaining fuel volume can be specified and the monitor configuration can be displayed.

The following 6 items appear when "UTILITIES" is selected.

- GAGE DATA
- REMOVE ALL GAGES

- SOFTWARE VERSION
- FAULT CONVERSION
- ANALOG INPUT
- OEM

Note:

"GAGE DATA" and "REMOVE ALL GAGES" are not supported on this machine.

### ■ Software Version

With "SOFTWARE VERSION", the software version of the monitor can be displayed.

### ■ Fault Conversion

With "FAULT CONVERSION", the J1939 fault code conversion method can be specified.

The monitor normally detects J1939 version 4.

Since the engine ECU of this machine uses J1939 version 4, no adjustments are necessary.

### ■ Analog Input

With "ANALOG INPUT", remaining fuel volume information can be specified. The following 2 items appear when "ANALOG INPUT" is selected.

- BACKLIGHT DIMMER
- FUEL LEVEL

### Important

"BACKLIGHT DIMMER" is not supported on this machine.

Always select "FUEL LEVEL".

If "BACKLIGHT DIMMER" is selected, "NO DATA" appears as the value for the fuel level parameter.

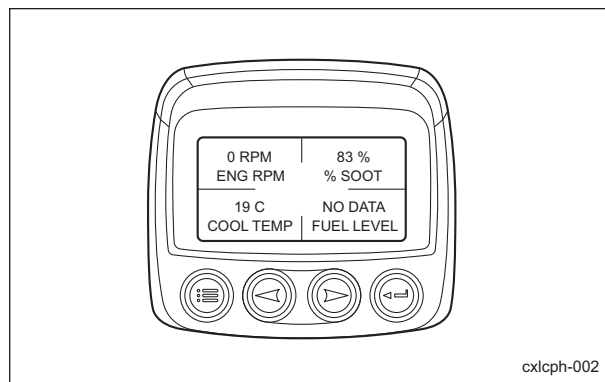

Analog Input\_001

Note:

The factory default analog input is "FUEL LEVEL".

# Handling Instructions

## 1. Fuel Level

With "FUEL LEVEL", the low fuel level can be specified.

### 1. Press the menu key.

After the main menu appears, use the arrow keys to highlight "UTILITIES", and then press the Enter key.

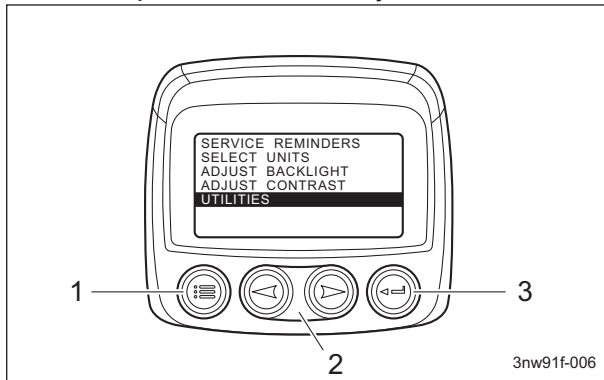

Fuel Level\_001

1	Menu key
2	Arrow keys
3	Enter key

### 2. Highlight "ANALOG INPUT", and then press the Enter key.

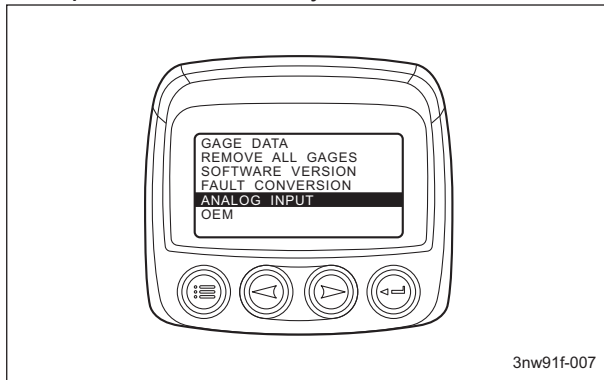

Fuel Level\_002

### 3. Highlight "FUEL LEVEL", and then press the Enter key.

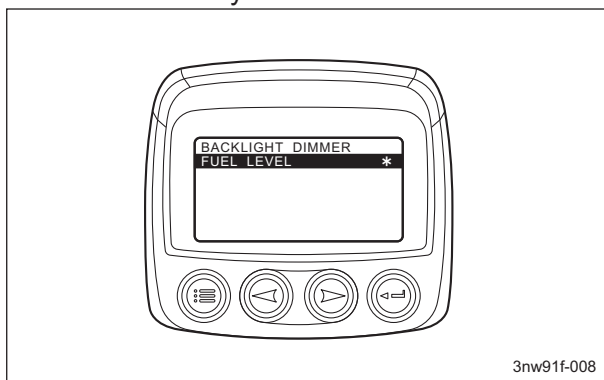

Fuel Level\_003

### 4. Highlight "SET LOW FUEL LEVEL", and then press the Enter key.

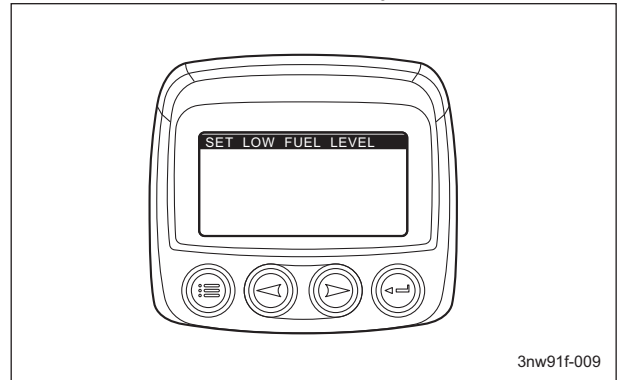

Fuel Level\_004

### 5. "LOW FUEL" appears.

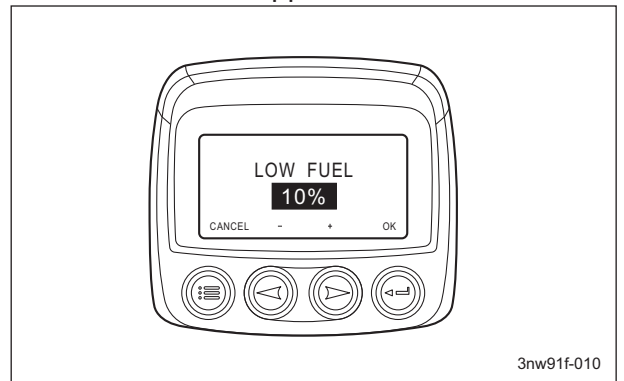

Fuel Level\_005

### 6. Press the right arrow key to increase the value. Press the left arrow key to decrease the value.

The value can be set between 10% and 80% in 5% increments.

### 7. To save the specified value, press the Enter key.

Note:

The factory default low fuel level is 10%.

# Handling Instructions

## 2. Low Fuel Level Display

**Important**

If a warning message appears, immediately stop operation, and then supply fuel.

1. When the fuel level falls below the specified low fuel level, a warning message appears in the monitor display and the LED (yellow) lights up. The warning message appears on two pages. Use the arrow keys to change the page.

• Text 1

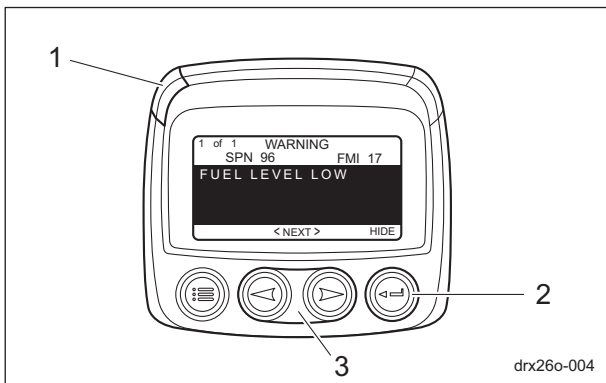

Low Fuel Level Display\_001

1	LED (yellow)
2	Enter key
3	Arrow keys

• Text 2

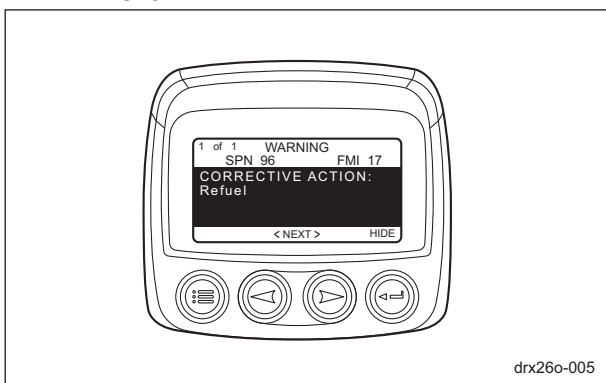

Low Fuel Level Display\_002

2. Pressing the Enter key changes the screen from the warning message to the parameter display.

3. A warning mark appears in the upper-right corner of the monitor display.

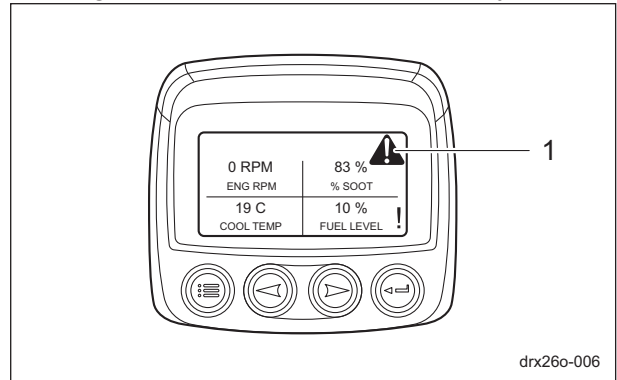

Low Fuel Level Display\_003

1	Warning mark
---	--------------

4. When fuel is supplied to bring the fuel level above the specified low fuel level, the warning message and mark disappear.

■OEM

"OEM" is used when the manufacturer specifies factory default settings.

**Important**

No adjustments by the operator are necessary.

# Handling Instructions

## Fault Code Displays

**Important**

When the fault code (DTC) appears in the monitor display, contact your dealer.

A fault code (DTC) appears in the monitor display when a failure occurs on the function of engine.

Each fault code is displayed over two pages. Use the arrow keys to change the page.

- Text 1  
The fault code name appears.

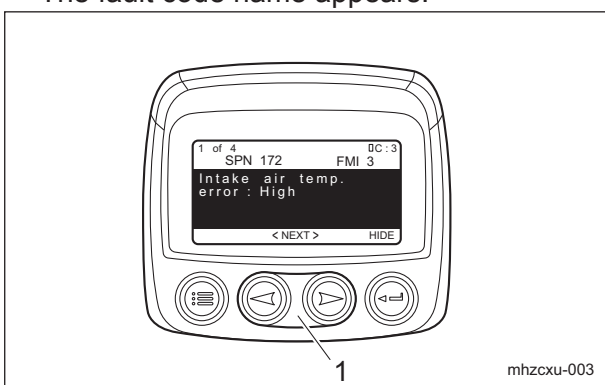

Fault Code Displays\_001

1	Arrow keys
---	------------

- Text 2  
The corrective action appears.

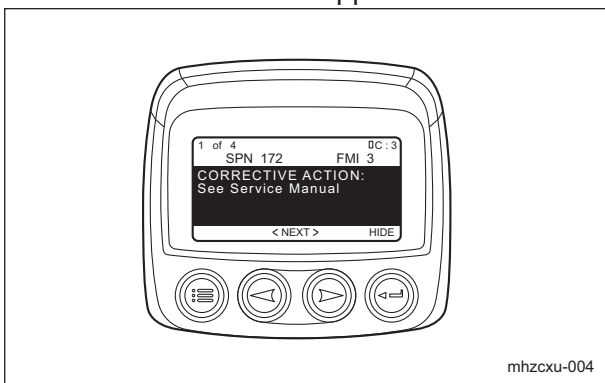

Fault Code Displays\_002

Pressing the Enter key changes the screen from the fault code to the parameter display.

**Important**

If the service reminders are configured, the notices of the replacement time period for consumables and the fault code may appear all together.

If the low fuel level is specified, the notices of fuel level low and the fault code may appear all together.

If "ACTIVE FAULTS - ECU" message appears, check both the service reminder warning message and the fault code (DTC).

To check the service reminder warning message:  
Highlight the service reminder notice, and then press the Enter key.

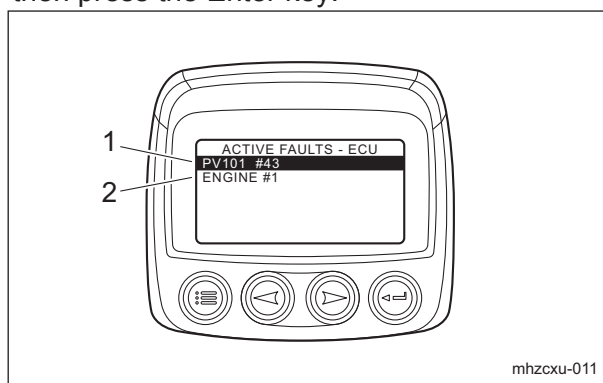

Fault Code Displays\_003

1	Service reminder notice
2	Fault code notice

- Text 1  
The item of requiring replacement of consumables appears.

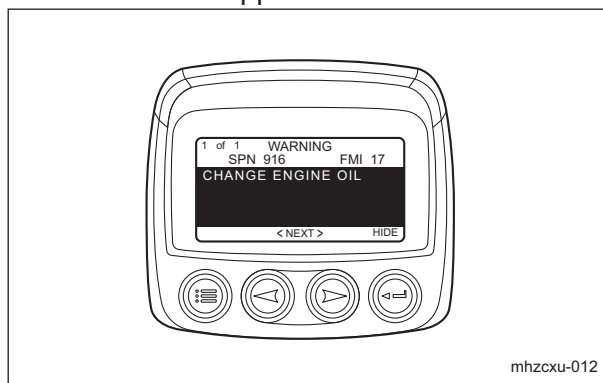

Fault Code Displays\_004

# Handling Instructions

• Text 2

The corrective action appears.

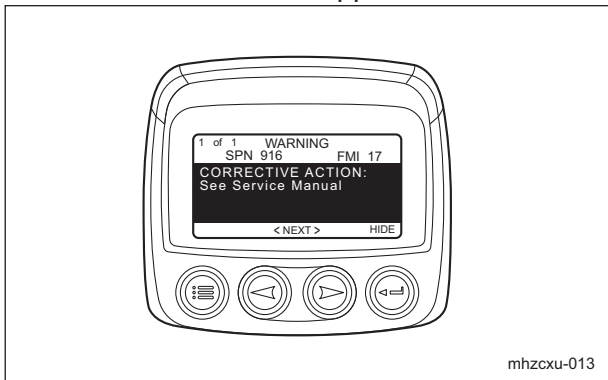

mhzcxu-013

Fault Code Displays\_005

To check the fault code (DTC):  
Highlight the fault code notice, and then press the Enter key.

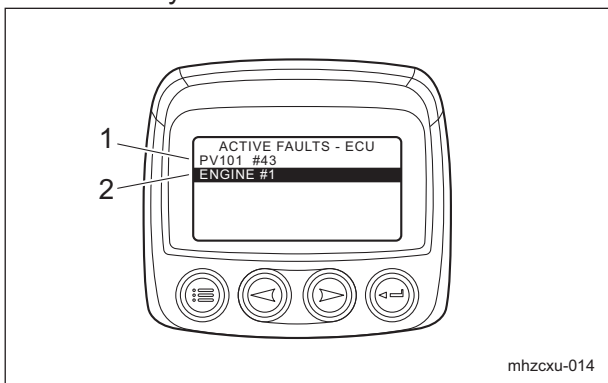

mhzcxu-014

Fault Code Displays\_006

1	Service reminder notice
2	Fault code notice

• Text 1

The fault code (DTC) name appears.

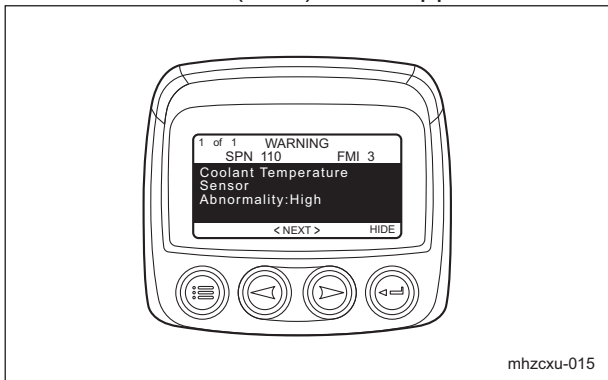

mhzcxu-015

Fault Code Displays\_007

• Text 2

The corrective action appears.

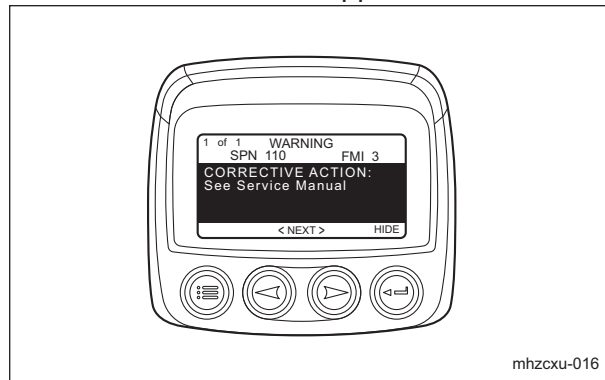

mhzcxu-016

Fault Code Displays\_008

Note:

If the warning message of service reminder ignored and the Enter key pressed to hide the message, the monitor will display "ACTIVE FAULTS - ECU".

If the fault code (DTC) ignored and the Enter key pressed, the monitor will also display "ACTIVE FAULTS - ECU".

If the notice ignored and the menu key pressed when the monitor displays "ACTIVE FAULTS - ECU", the warning mark continues to be displayed in the upper right corner of the monitor display.

To check the warning message and the fault code (DTC) again, press the Enter key to return to the display of "ACTIVE FAULTS - ECU".

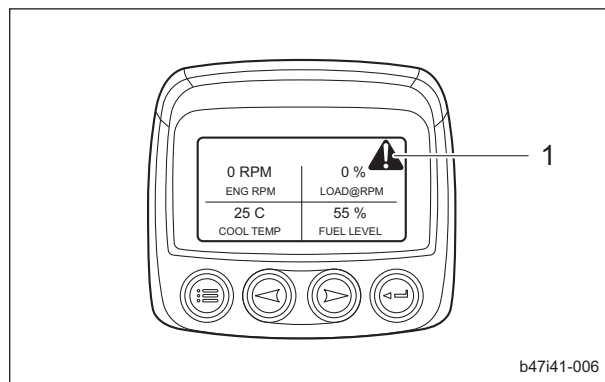

b47i41-006

Fault Code Displays\_009

1	Warning mark
---	--------------

# Handling Instructions

## Engine Warning Lamp

**Important**

Make repairs immediately if the fault codes of PCD (Particulate Control Diagnostic) and NCD (NOx Control Diagnostic) appear.

Engine warning lamp (LED) lights up or blinks when a failure occurs on the function of engine. Check the fault code (DTC) in the monitor display.

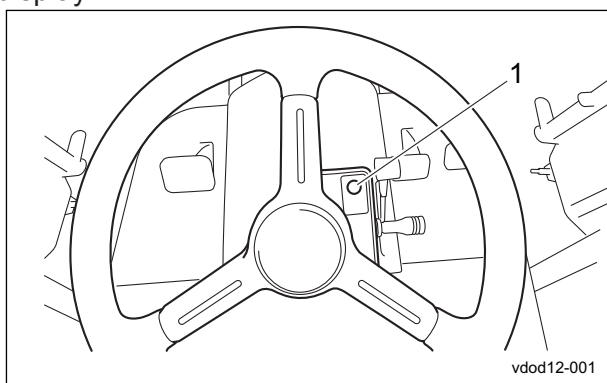

Engine Warning Lamp\_001

1	Engine warning lamp
---	---------------------

The lighting patterns of engine warning lamp are as follows.

Note :

PCD means fault codes relevant to Particulate Control Diagnostic.

NCD means fault codes relevant to NOx Control Diagnostic.

1. Engine warning lamp lights up when only DTC other than PCD/NCD come up.

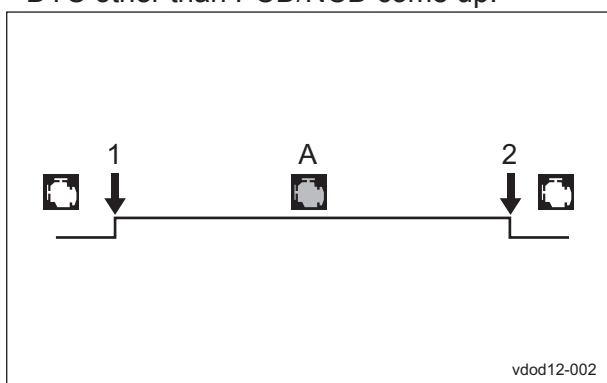

Engine Warning Lamp\_002

1	Fault detected
2	Recovery
A	Lighting

2. Engine warning lamp blinks when only DTC relevant to PCD/NCD come up.

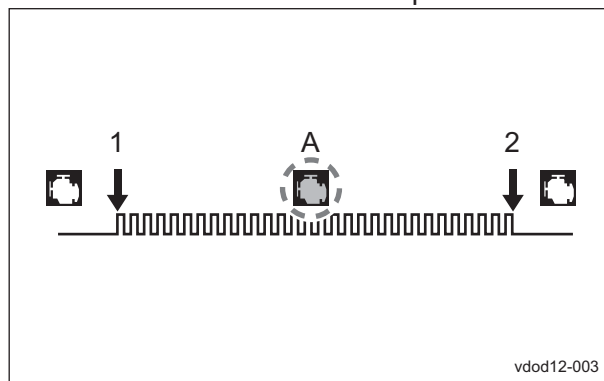

Engine Warning Lamp\_003

1	Fault detected
2	Recovery
A	Blinking

3. Engine warning lamp repeats blinking and lighting alternately when DTC relevant to/ other than PCD/NCD come up at the same time. (It repeats blinking three times and lighting three seconds.)

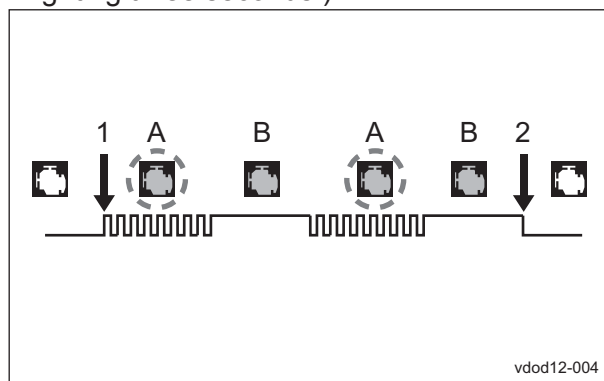

Engine Warning Lamp\_004

1	Fault detected
2	Recovery
A	Blinking
B	Lighting

# Handling Instructions

## Move

### Traveling Procedure

#### ⚠ Caution

Under any circumstances drive the machine at such a speed that you can stop it immediately for emergencies.

#### ⚠ Caution

When traveling, be sure to stop the rotary knives and raise the mower decks.

#### Important

Do NOT start to move or stop the machine abruptly. It will damage the hydraulic system or result in oil leakage.

1. Start the engine.  
"Procedure to Start Engine" (Page 4-22)
2. Make sure that all the mower decks are raised and that the mower lock levers (latches) for mower decks #4 and #5 are hooked.
3. Depress the brake pedal to release the parking brake.
4. Release the brake pedal.
5. Slowly depress the traveling pedal.
6. The machine starts traveling.
7. The machine stops slowly when the traveling pedal released.

### Towing The Machine

If the machine does not travel due to engine trouble, etc., you can move it by towing it.

#### ⚠ Caution

Before towing, check that the brake is applied effectively.

#### ⚠ Caution

Before starting the engine, be sure to close the unload valves.

#### Important

Do not touch the unload valve except when towing the machine.

#### Important

When towing the machine, travel at a speed no more than 3.0 km/h.

In addition, do not tow the machine for more than 3 minutes.

If the towing speed is too fast or there is excessive movement, the pump or motor will be damaged.

1. Stop the engine.  
"Procedure to Stop Engine" (Page 4-23)
2. Apply the parking brake.
3. Chock the wheels.
4. Secure the machine with ropes.

Front left side

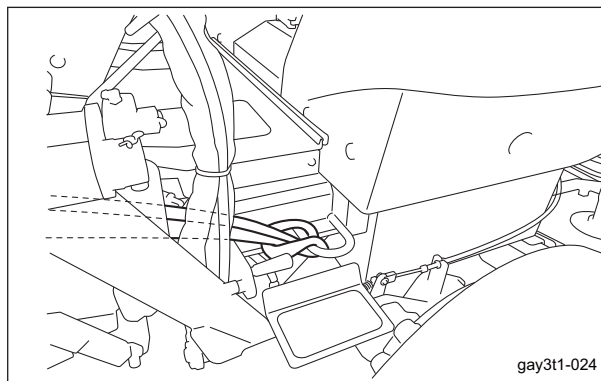

gay311-024

Towing The Machine\_001

Front right side

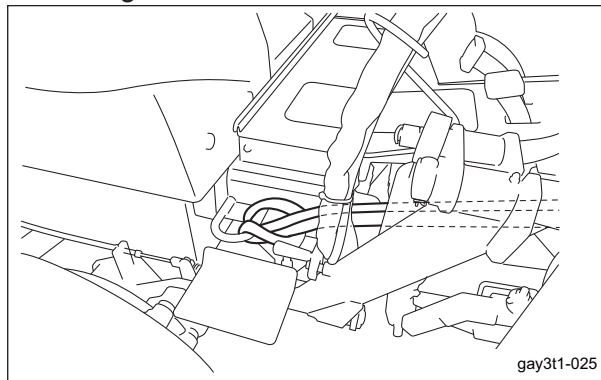

gay311-025

Towing The Machine\_002



# Handling Instructions

Rear side

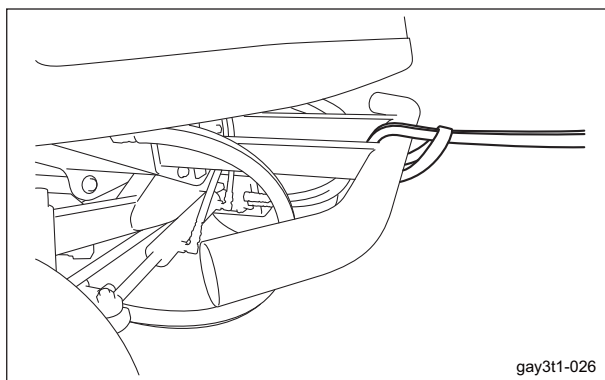

gay3t1-026

Towing The Machine\_003

5. Set the 2WD/4WD selector switch to the "2WD" position.
6. Open the underseat cover. "Underseat Cover" (Page 4-36)
7. Turn the needle valve, located beside the hydraulic pump, 90 degrees (so that it is vertical) to open the unload valve.

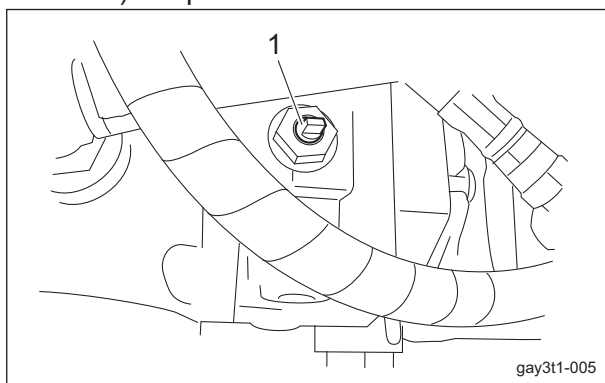

gay3t1-005

Towing The Machine\_005

1 Needle valve

8. Close the underseat cover.
9. Remove the wheel stopper.
10. Depress the brake pedal to release the parking brake.

### Warning

While towing, always keep your foot on the brake pedal and depress the brake pedal at any time to stop.

11. Tow the machine slowly.

## Cutting Work

### Cutting Operation

#### Caution

Cutting work must be performed at an appropriate speed for the site and location. When cutting bumpy surfaces, keep the engine rpm steady, and slow down the cutting speed.

#### Caution

Please note that if you stop operating the mower deck up/down lever before the mower decks are raised completely, knife rotation may not stop. Knife rotation will be turned on or off based on the sensor-detected position of the mower decks.

#### Caution

Be sure that people around the machine keep a safe distance away.

#### Important

Do NOT start to move or stop the machine abruptly. It will damage the hydraulic system or result in oil leakage.

1. Release the mower lock levers for mower decks #4 and #5 just before cutting operation.
2. Start the engine. "Procedure to Start Engine" (Page 4-22)
3. Depress the brake pedal to release the parking brake.
4. Shift the throttle knob to rev the engine up to the maximum rpm.
5. Shift the mower deck up/down lever to the "Lower" position to lower the mower decks.
6. Set the knife rotation switch to the "Rotation" position to rotate the rotary knives of all mower decks.
7. Depress the traveling pedal to start cutting work.

# Handling Instructions

---

**Note:**

During the work, the rotary knives will rotate or stop in sync with the up and down motion of the mower decks.

## Transporting

### Transporting Procedure

When loading the machine into a trailer or a truck to transport it, drive the machine forward. When unloading, drive the machine in reverse. If the roof is installed on the machine, remove it.

The roof may be damaged by wind pressure.

## Storage

### Before Long-Term Storage

1. Cleaning
  - Remove dirt, grass clippings, oil stains etc. completely from the main vehicle and engine.
2. Replacing oil
  - Inspect and replace the engine oil, hydraulic oil and element.
3. Greasing and lubricating
  - Supply oil and apply grease to appropriate parts.
4. Battery
  - Remove the negative battery wire.
5. Fuel
  - Remove the fuel from the fuel tank.
6. Tire pneumatic pressure
  - Set the tire air pressure slightly higher than normal, and then place the machine on a board to avoid humidity.
7. Mower decks
  - When storing this machine, lower all the mower decks unless a positive mechanical lock is provided.
8. Storage location
  - Cover the machine and store it in a dry place where it will not be exposed to rain.

<b>Maintenance Precautions .....</b>	<b>Page 5-2</b>
<b>Maintenance Schedule .....</b>	<b>Page 5-2</b>
Adjusted Value .....	Page 5-7
<b>DPF .....</b>	<b>Page 5-8</b>
About DPF .....	Page 5-8
DPF Regeneration .....	Page 5-8
Replacement of DPF .....	Page 5-13
Conditions for DPF Regeneration .....	Page 5-14
PM Accumulation Level .....	Page 5-14
<b>Jacking Up The Machine .....</b>	<b>Page 5-20</b>
About Jacking Up The Machine .....	Page 5-20
Jack-Up Points .....	Page 5-20
<b>Greasing .....</b>	<b>Page 5-21</b>
About Greasing .....	Page 5-21
Greasing Points .....	Page 5-21
<b>Lubrication .....</b>	<b>Page 5-24</b>
About Lubrication .....	Page 5-24
Lubricating Points .....	Page 5-24
<b>Maintenance Work .....</b>	<b>Page 5-25</b>
Cleaning of Mower Deck .....	Page 5-25
Change of Rotary Knife .....	Page 5-25
Grinding of Rotary Knife .....	Page 5-29
Balancing of Rotary Knife .....	Page 5-30
Removing/Installing Tires .....	Page 5-31
Adjustment of Belt Tension .....	Page 5-32
Adjustment of Brake .....	Page 5-32
Adjusting the Neutral Position of the Piston Pump .....	Page 5-34
Change of Coolant .....	Page 5-35
Change of Hydraulic Oil .....	Page 5-36
Change of Hydraulic Oil Filter .....	Page 5-37
Change of Air Cleaner .....	Page 5-39
Change of Engine Oil .....	Page 5-39
Replacement of Engine Oil Filter .....	Page 5-40
Replacement of Fuel Filter .....	Page 5-40
Change of Fuse .....	Page 5-41

# Maintenance

## Maintenance Precautions

### Warning

The chapter "Maintenance" in this manual describes practical measures which should be performed by a mechanic with expertise. The owner should instruct the mechanic with expertise to perform maintenance service for this machine.

### Caution

First, learn well the maintenance operations you plan to perform.

### Important

Use tools appropriate for each maintenance operation.

### Important

For the safe and best performance of your machine, use Baroness genuine parts for replacement and accessories. Please note that our product warranty may be void if you use non-genuine parts for replacement or accessories.

Maintain the machine according to the maintenance schedule so that you will be able to take advantage of its optimum performance for a long period of time.

## Maintenance Schedule

GM2810A

Follow the maintenance schedule below.

○ . . . Inspect, adjust, supply, clean

● . . . Replace (first time)

△ . . . Replace

Maintenance Item		Before Work	After Work	Every Week	Every 50 hrs.	Every 100 hrs.	Every 250 hrs.	Every 400 hrs.	Every 500 hrs.	Every 800 hrs.	Every 1000 hrs.	Every 1500 hrs.	Every 3000 hrs.	Every month	Every year	Every 2 years	Every 4 years	When Required	Remarks
*4	Check engine oil level and contamination	○																	
*4	Check fuel level	○																	
*4	Check coolant level	○																	
*4	Check fan belt	○																	

# Maintenance

Maintenance Item		Before Work	After Work	Every Week	Every 50 hrs.	Every 100 hrs.	Every 250 hrs.	Every 400 hrs.	Every 500 hrs.	Every 800 hrs.	Every 1000 hrs.	Every 1500 hrs.	Every 3000 hrs.	Every month	Every year	Every 2 years	Every 4 years	When Required	Remarks
	Check hydraulic oil level	<input type="radio"/>																	
	Check tire pressures and condition	<input type="radio"/>																	
	Check rotary knife condition	<input type="radio"/>																	
	Check roller condition	<input type="radio"/>																	
	Check interlock system safety function	<input type="radio"/>																	
	Check oil or water leaks	<input type="radio"/>																	
	Check cover condition	<input type="radio"/>																	
	Check damaged parts	<input type="radio"/>																	
	Check tightening bolts and nuts	<input type="radio"/>																	
	Check brake function	<input type="radio"/>																	
	Check hydraulic hoses condition	<input type="radio"/>																	
	Clean machine exterior		<input type="radio"/>																
	Clean engine area		<input type="radio"/>																
	Open air cleaner evacuator valve to remove dust		<input type="radio"/>	<input type="radio"/>															Open valve every week or daily in dusty conditions
	Clean radiator core		<input type="radio"/>																
	Clean oil cooler core		<input type="radio"/>																
*4	Check fuel hoses and clamp bands				<input type="radio"/>														
*4	Draining of water separator				<input type="radio"/>														
	Grease and Lubricate all moving parts				<input type="radio"/>														
	Grease rear mower deck swing out pins				<input type="radio"/>														
	Check and Adjust brakes				<input type="radio"/>														
	Check wheel mounting bolts looseness				<input type="radio"/>	<input type="radio"/>													50 hours first change, every 100 hours thereafter
*4	Clean air cleaner outer element (Replace the element after 6-time cleaning)					<input type="radio"/>									<input type="checkbox"/>				Replace every 6 cleanings or every year

Maintenance

# Maintenance

Maintenance Item		Before Work	After Work	Every Week	Every 50 hrs.	Every 100 hrs.	Every 250 hrs.	Every 400 hrs.	Every 500 hrs.	Every 800 hrs.	Every 1000 hrs.	Every 1500 hrs.	Every 3000 hrs.	Every month	Every year	Every 2 years	Every 4 years	When Required	Remarks
*4	Clean air cleaner outer element (Replace the element after 6-time cleaning)					○									△				whichever comes earlier Air cleaner should be cleaned more often in dusty conditions than in normal conditions
	Replace hydraulic oil					●			△										100 hours first change, every 500 hours thereafter
	Replace hydraulic oil filter					●			△										100 hours first change, every 500 hours thereafter
*5	Check exterior of battery					○								○					Check every 100 hours or every month whichever comes earlier
*5	Clean exterior of battery					○								○					Check every 100 hours or every month whichever comes earlier
*5	Check mounting bracket of battery					○								○					Check every 100 hours or every month whichever comes earlier
*5	Check looseness and corrosion of battery terminals					○								○					Check every 100 hours or every month whichever comes earlier
*5	Check battery fluid level					○								○					Check every 100 hours or every month whichever comes earlier
*4	Adjust fan belt tension					○													
*4	Check radiator hoses and clamp bands						○												

## Maintenance

Maintenance Item		Before Work	After Work	Every Week	Every 50 hrs.	Every 100 hrs.	Every 250 hrs.	Every 400 hrs.	Every 500 hrs.	Every 800 hrs.	Every 1000 hrs.	Every 1500 hrs.	Every 3000 hrs.	Every month	Every year	Every 2 years	Every 4 years	When Required	Remarks
*4	Check intake air line (air cleaner hose)						○								○				Check every 250 hours or every year whichever comes earlier
*4	Change engine oil				●			△							△				Initial 50 hours, thereafter every 400 hours or every year whichever comes earlier
*4	Replace oil filter cartridge				●			△							△				Initial 50 hours, thereafter every 400 hours or every year whichever comes earlier
*1.*4	Replace fuel filter cartridge							△											
*4	Clean water separator								○										
*2.*4	Clean fuel tank interior								○										
*2.*4	Clean water jacket and radiator interior								○										
*2.*4	Replace fan belt								△							△			Replace every 500 hours or 2 years whichever comes earlier
	Replace hydraulic suction filter								△										
*2.*4	Check valve clearance								○										
*2.*3.* 4	Check injector											○							
*2.*3.* 4	Check EGR cooler											○							
*3.*4	Replace oil separator element											△							
*2.*3.* 4	Check PCV (Positive Crankcase Ventilation) Valve in the oil separator body											○							
*2.*3.* 4	Check turbocharger												○						
*2.*3.* 4	Replace DPF filters												△						

# Maintenance

Maintenance Item		Before Work	After Work	Every Week	Every 50 hrs.	Every 100 hrs.	Every 250 hrs.	Every 400 hrs.	Every 500 hrs.	Every 800 hrs.	Every 1000 hrs.	Every 1500 hrs.	Every 3000 hrs.	Every month	Every year	Every 2 years	Every 4 years	When Required	Remarks
*2.*3.* 4	Check EGR system												○						
	Check electrical wiring condition (Damage, defacement and joint looseness)														○				
*2.*4	Replace air cleaner inner element														△				The secondary (inner) element should be removed only if it is to be replaced.
*2.*4	Check DPF differential pressure pipes and hoses														○				
*2.*4	Check EGR piping														○				
*4	Check exhaust manifold (Crack, gas leakage and mounting screw)														○				
*2.*4	Replace oil separator rubber hose															△			
*2.*4	Replace rubber hose of DPF differential pressure sensor															△			
*2.*4	Replace intake hose (After air flow sensor) and inter cooler hose															△			
*2.*4	Replace rubber hose of boost pressure sensor															△			
*2.*4	Replace EGR cooler hose															△			
*2.*4	Replace water hose															△			
*2.*4	Replace lubricant hose															△			
*4	Change radiator coolant (L.L.C.)															△			
*2.*4	Replace radiator hoses and clamp bands															△			
*1.*2.* 4	Replace fuel hoses and clamps															△			
*2.*4	Replace intake air line (air cleaner hose)															△			
	Replace hydraulic hoses (Moving part)															△			



# Maintenance

Maintenance Item		Before Work	After Work	Every Week	Every 50 hrs.	Every 100 hrs.	Every 250 hrs.	Every 400 hrs.	Every 500 hrs.	Every 800 hrs.	Every 1000 hrs.	Every 1500 hrs.	Every 3000 hrs.	Every month	Every year	Every 2 years	Every 4 years	When Required	Remarks
*6	Replace hydraulic hoses (Moving part) relating to steering															△			
	Replace hydraulic hoses (Fixed part)																△		
	Replace brake pads																	△	
	Replace brake cables																	△	
	Sharpen and balance rotary knife																	○	Sharpen/ Balance/ Replace rotary knife if needed.
*5	Replace battery																	△	

- \*1: When biodiesel fuel is used, change the fuel filter cartridge, fuel hose and clamp bands with new ones at intervals half of the usual ones.
- \*2: Consult your local Baroness Dealer or local KUBOTA Dealer for this service.
- The items above (\*3 marked) are registered as emission related critical parts by KUBOTA in the U.S. EPA nonroad emission regulation.  
As the engine owner, you are responsible for the performance of the required maintenance on the engine according to the above instruction.  
Please see the Engine's Warranty Statement in detail.
- \*4: Refer to the Engine's Owner's Manual.
- \*5: Refer to the Battery's Owner's Manual.
- The values for consumables are not guaranteed.
- \*6: Be sure to replace hydraulic hoses for steering cylinder and hydraulic hoses for hydraulic motor of wheel relating to steering every two years.

## Adjusted Value

Fan belt	7.0 - 9.0 mm (0.28 - 0.35 in)	Belt slack when belt pressed with 98 N (10 kgf) at the middle point.
Brake	0.2 mm (0.0079 in)	Clearance between the brake disc and the pad
	1.0 mm (0.039 in)	Play at the connection of the inner wire

# Maintenance

## DPF

### About DPF

The DPF is a purifying filter that collects PM (soot) from exhaust gas.

When a certain amount of PM (soot) has accumulated, DPF regeneration must be performed automatically or manually in order to restore the filtering function.

### DPF Regeneration

#### **Danger**

Since it will become extremely hot around the exhaust outlet during DPF regeneration, do not perform the regeneration in a location where fires may occur.

#### Important

When the system enters the level where DPF regeneration is required, perform the regeneration immediately.

Interrupting the regeneration or ignoring the warning and continuing traveling or cutting work may cause the engine and DPF to malfunction.

#### Important

Do not repeat unnecessary regeneration or interrupting regeneration.

If repeating them, the measured level of engine oil may increase since the engine oil is mixed with a slight amount of fuel, accompanied by quality degradation.

#### Important

Perform DPF regeneration when the engine sufficiently warmed up.

DPF regeneration is burning PM (soot) collected in DPF with the exhaust temperature heated up to high temperature by the engine ECU control of intake air mass and fuel injection.

### Automatic Regeneration

#### **Danger**

Since it will become extremely hot around the exhaust outlet during DPF regeneration, do not perform the regeneration in a location where fires may occur.

#### **Caution**

Normally, set the DPF auto regeneration inhibit switch to the "Auto regeneration mode". However, when operating in a location where fires may occur, set the DPF auto regeneration inhibit switch to the "Auto regeneration inhibit mode".

#### Important

When the system enters the level where DPF regeneration is required, perform the regeneration immediately.

Interrupting the regeneration can cause the engine and DPF to malfunction.

Automatic regeneration is the automatic control of increasing the exhaust temperature for DPF regeneration.

- You can continue to use this machine for traveling and cutting work during DPF regeneration.
- You can operate this machine to perform the regeneration. (The fault diagnostic tool is not required.)
- Automatic regeneration is activated only when the auto regeneration inhibit switch set to the "Auto regeneration mode".
- Automatic regeneration is activated when PM accumulation level is "Level 1" or "Level 2".

However, it may be activated in "Level 0" depending on the other condition.

**Important**

If the regeneration remains uncompleted even after 30 minutes have passed since the start of automatic regeneration in PM accumulation "Level 1", PM accumulation level enters "Level 2".

These are the procedures of automatic regeneration.

■ When the DPF auto regeneration inhibit switch set to the "Auto regeneration mode":

1. When the conditions for automatic regeneration are met, the automatic regeneration starts with the regeneration icon lighting.
2. When the regeneration completed, the regeneration icon disappears.

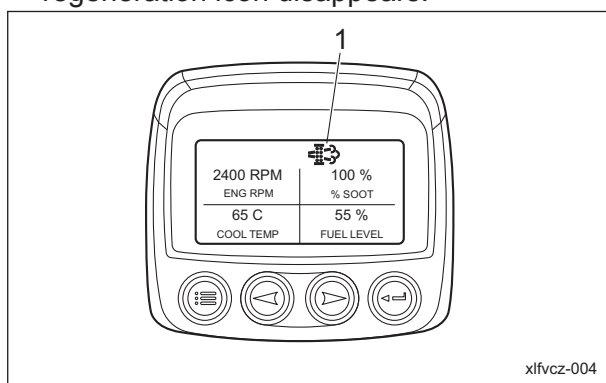

Automatic Regeneration\_001

1 | Regeneration icon

■ When the DPF auto regeneration inhibit switch set to the "Auto regeneration inhibit mode":

1. When PM accumulation level enters "Level 1" or "Level 2", the blinking regeneration icon appears.
2. Set the DPF auto regeneration inhibit switch to the "Auto regeneration mode".
3. When the conditions for automatic regeneration are met, the automatic regeneration starts and the regeneration icon changes from blinking to lighting.
4. When the regeneration completed, the regeneration icon disappears.

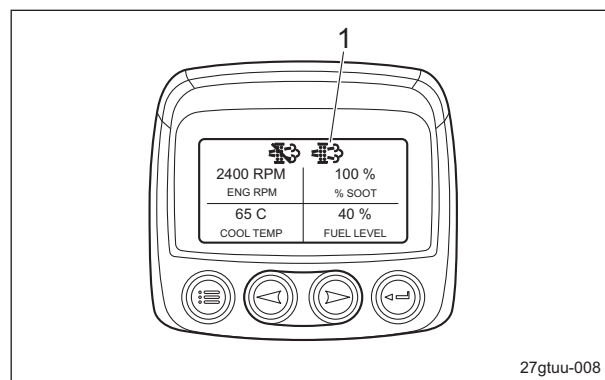

27gtuu-008

Automatic Regeneration\_002

1 | Regeneration icon

**Parked Regeneration****⚠ Danger**

Since it will become extremely hot around the exhaust outlet during DPF regeneration, do not perform the regeneration in a location where fires may occur.

**Important**

When the system enters the level where DPF regeneration is required, perform the regeneration immediately.

Interrupting the regeneration or ignoring the warning and continuing traveling or cutting work may cause the engine and DPF to malfunction.

**Important**

Parked regeneration can not be performed as long as the DPF auto regeneration inhibit switch set to the "Auto regeneration inhibit mode".

Set it to the "Auto regeneration mode" to perform regeneration.

Parked regeneration is the DPF regeneration forcibly performed, parking this machine in a safe location, when auto regeneration does not reduce the amount of accumulated PM to the specified value.

- You can not continue to use this machine for traveling and cutting work during DPF regeneration.
- You can operate this machine to perform the regeneration. (The fault diagnostic tool is not required.)

# Maintenance

- These are the conditions for activating parked regeneration.
  1. The parking brake is applied.
  2. The traveling pedal is in neutral.
  3. The throttle opening is 0% (idling).
- Parked regeneration is activated when PM accumulation level is "Level 1", "Level 2" or "Level 3".

**Important**

If the regeneration remains uncompleted in automatic regeneration, parked regeneration is required with the blinking regeneration icon.

■ In PM accumulation "Level 1" or "Level 2":

**Important**

If ignoring the parked regeneration requirement and continuing traveling or cutting work in PM accumulation "Level 1" or "Level 2", PM accumulation level enters "Level 2" or "Level 3".

Follow the steps below for parked regeneration.

1. When PM accumulation level enters "Level 1" or "Level 2", the blinking regeneration icon appears.  
When the DPF auto regeneration inhibit switch set to the "Auto regeneration mode":

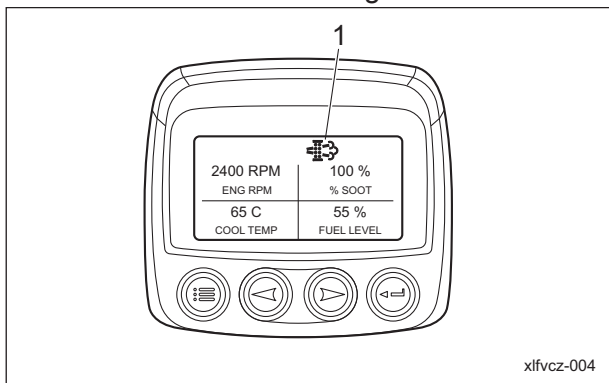

Parked Regeneration\_001

1	Regeneration icon
---	-------------------

When the DPF auto regeneration inhibit switch set to the "Auto regeneration inhibit mode":

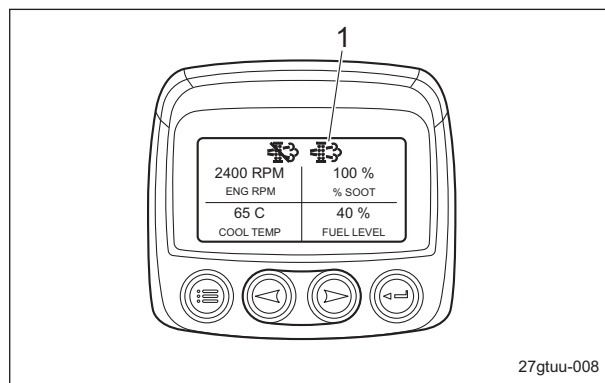

Parked Regeneration\_002

1	Regeneration icon
---	-------------------

2. Stop traveling and cutting work.
3. Park this machine in a safe location.
4. Apply the parking brake.
5. Set the throttle opening to 0% (idling).
6. If the DPF auto regeneration inhibit switch set to the "Auto regeneration inhibit mode," set it to the "Auto regeneration mode."
7. Press the DPF parked regeneration switch. Parked regeneration starts and the regeneration icon changes from blinking to lighting.
8. When the regeneration completed, the regeneration icon disappears.

■ In PM accumulation "Level 3":

**Important**

If ignoring the parked regeneration requirement and continuing traveling or cutting work in PM accumulation "Level 3", PM accumulation level enters "Level 4". If still continuing traveling or cutting work, you will not be able to operate this machine for regeneration.

**Important**

Automatic regeneration can not be activated in PM accumulation "Level 3". Perform parked regeneration immediately.

1. These are the statuses in PM accumulation "Level 3".

- "Excessive PM3" appears in the monitor display.  
Pressing an arrow key changes the display to "CORRECTIVE ACTION: Start DPF Parked Regeneration immediately".
- The LED (yellow) lights up.
- The engine output is limited at 50%.

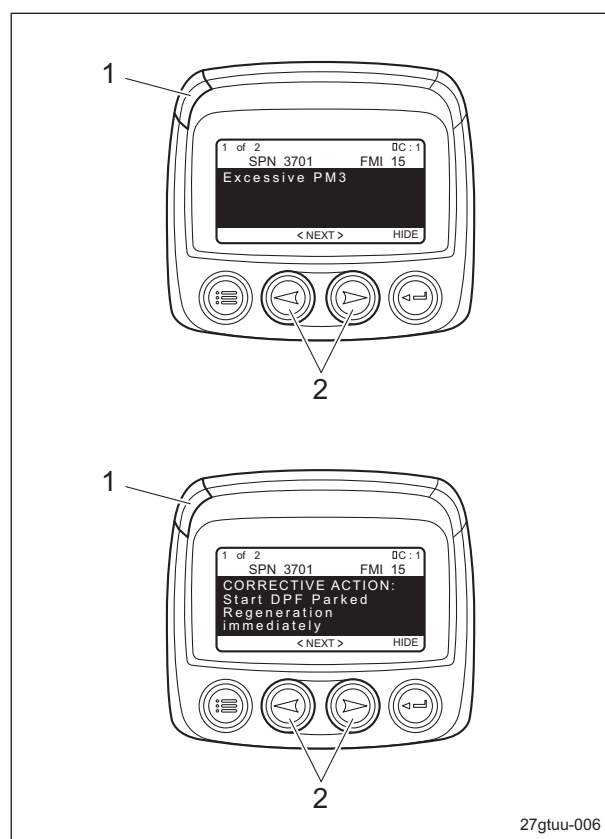

27gtuu-006

Parked Regeneration\_003

1	LED (yellow)
2	Arrow key

2. Stop traveling and cutting work.
3. Park this machine in a safe location.
4. Apply the parking brake.
5. Set the throttle opening to 0% (idling).
6. Press the DPF parked regeneration switch. Parked regeneration starts and the regeneration icon changes from blinking to lighting.
7. When the regeneration completed, the regeneration icon disappears.

# Maintenance

## Manual Regeneration

### **Danger**

Since it will become extremely hot around the exhaust outlet during DPF regeneration, do not perform the regeneration in a location where fires may occur.

### Important

When the system enters the level where DPF regeneration is required, perform the regeneration immediately. Interrupting the regeneration or ignoring the warning and continuing traveling or cutting work may cause the engine and DPF to malfunction.

### Important

Manual regeneration can not be performed as long as the DPF auto regeneration inhibit switch set to the "Auto regeneration inhibit mode". Set it to the "Auto regeneration mode" to perform regeneration.

Manual regeneration is the DPF regeneration performed only by the expert with the fault diagnostic tool. Normal automatic regeneration or parked regeneration can not complete regeneration since large amount of PM accumulates.

Manual regeneration can be activated in any PM accumulation level.

- You can not continue to use this machine for traveling and cutting work during DPF regeneration.
- You can not perform the regeneration. (The fault diagnostic tool is required.)
- Manual regeneration is activated in PM accumulation "Level 4".
- Manual regeneration is activated in any PM accumulation level when the following condition met.

1. when replacing DPF
2. when replacing ECU

### ■ In PM accumulation "Level 4":

#### Important

If ignoring the manual regeneration requirement and continuing traveling or cutting work in PM accumulation "Level 4", PM accumulation level enters "Level 5". If still continuing traveling or cutting work, fatal trouble will occur on the engine and DPF.

1. These are the statuses in PM accumulation "Level 4".

- "Excessive PM4" appears in the monitor display. Pressing an arrow key changes the display to "CORRECTIVE ACTION: Stop engine!! Contact dealer immediately".
- The LED (yellow) lights up.
- The engine output is limited at 50%.

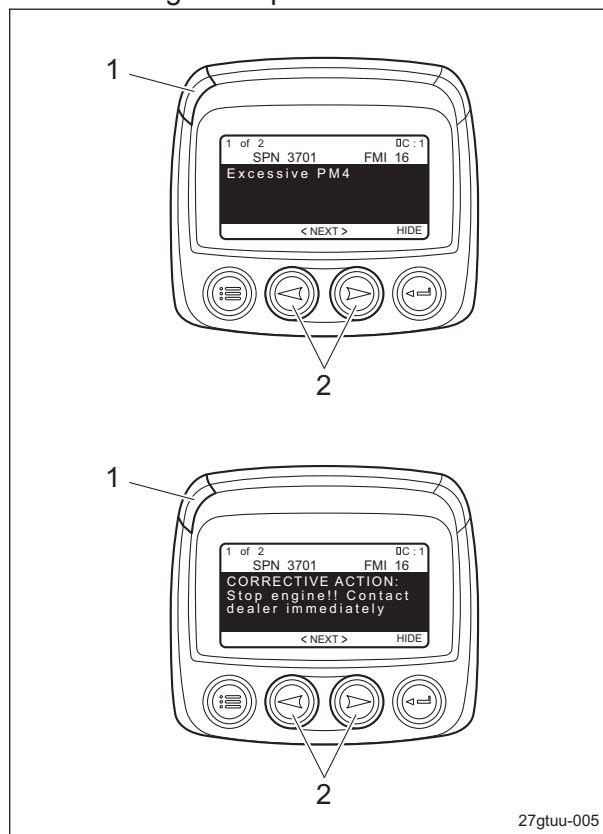

27gtuu-005

Manual Regeneration\_001

1	LED (yellow)
2	Arrow key

2. Stop traveling and cutting work.
3. Park this machine in a safe location.
4. Apply the parking brake.
5. Stop the engine.

- Contact your dealer for manual regeneration.

## Replacement of DPF

When PM accumulates excessively in the DPF or ash accumulates, replace the DPF since the regeneration in that case is prohibited.

- You can not continue to use this machine for traveling and cutting work.
- The regeneration is impossible.
- Replace every 3,000 hours.
- Replace DPF in PM accumulation "Level 5" or "High frequency of regeneration".

■ In PM accumulation "Level 5":

- These are the statuses in PM accumulation "Level 5".
  - "Excessive PM5" appears in the monitor display.  
Pressing an arrow key changes the display to "CORRECTIVE ACTION: Stop engine!! Contact dealer immediately".
  - The LED (red) lights up.
  - The engine output is limited at 50%.

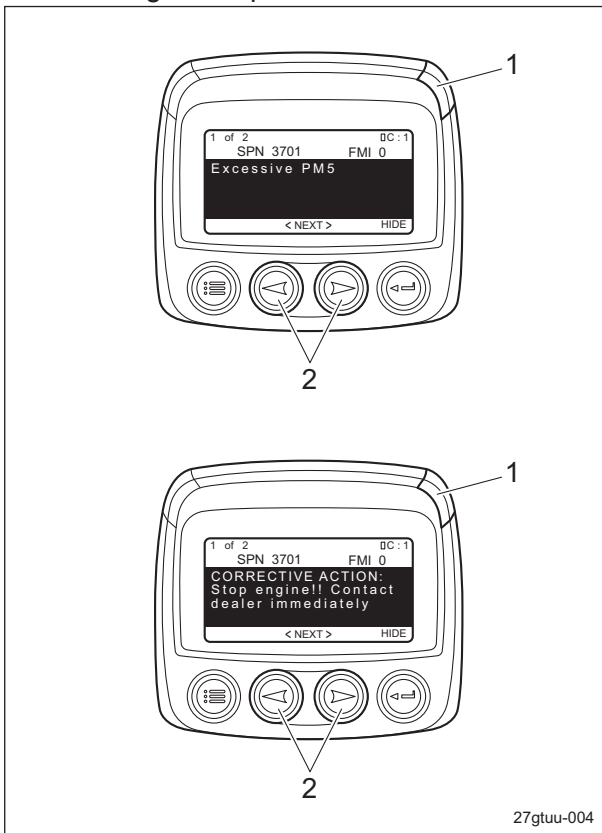

Replacement of DPF\_001

1	LED (red)
2	Arrow key

- Stop traveling and cutting work.

- Park this machine in a safe location.
- Apply the parking brake.
- Stop the engine.
- Contact your dealer for DPF replacement.

■ In the case of "High frequency of regeneration" :

- These are the statuses in the case of "High frequency of regeneration".
  - "High frequency of regeneration" appears in the monitor display.  
Pressing an arrow key changes the display to description of corrective action.
  - The LED (yellow) lights up.
  - The engine output is limited at 50%.

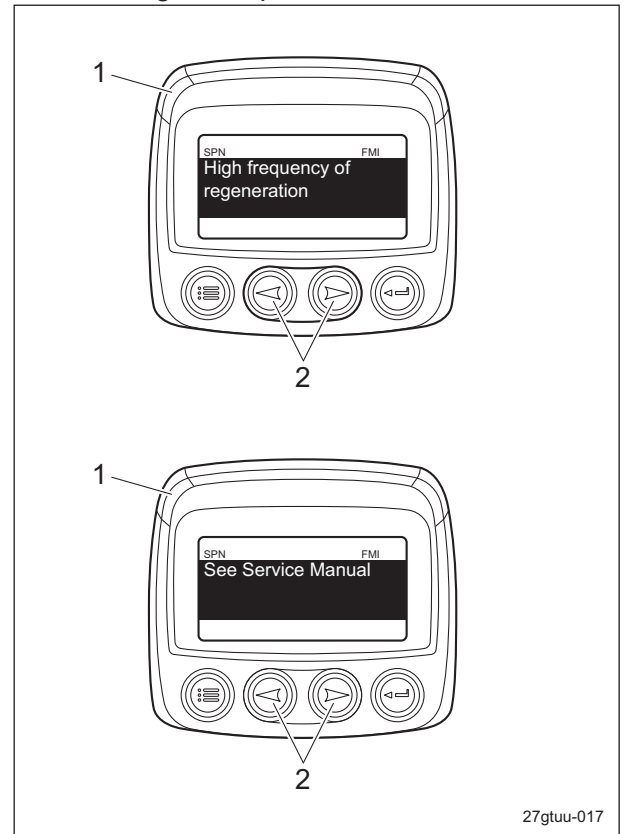

Replacement of DPF\_002

1	LED (yellow)
2	Arrow key

- Stop traveling and cutting work.
- Park this machine in a safe location.
- Apply the parking brake.
- Stop the engine.
- Contact your dealer for DPF replacement.



# Maintenance

## Conditions for DPF Regeneration

### Danger

Since it will become extremely hot around the exhaust outlet during DPF regeneration, do not perform the regeneration in a location where fires may occur.

### Important

If DPF regeneration is interrupted before it is completed, the next regeneration may be requested soon since not all of the PM (soot) was removed.

### Important

Perform DPF regeneration when the engine sufficiently warmed up.

1. DPF auto regeneration does not begin unless both of the following two conditions are met.
  - The DPF auto regeneration inhibit switch is set to the "Auto regeneration mode". (Auto regeneration inhibit icon is turned off.)
  - The coolant temperature is 50 °C or more.
2. DPF parked regeneration and manual regeneration do not begin unless all of the following five conditions are met.
  - The DPF auto regeneration inhibit switch is set to the "Auto regeneration mode". (Auto regeneration inhibit icon is turned off.)
  - The parking brake is applied.
  - The traveling pedal is in the neutral position.
  - The throttle opening is 0% (idling).
  - The coolant temperature is 50 °C or more.
3. During DPF regeneration, the operation is canceled if any of the following conditions occur.
  - Any condition for starting regeneration is violated.
  - The ignition key is switched to the "OFF" position.

## PM Accumulation Level

### Level 0

DPF regeneration is not necessary.

### Level 1

### Danger

Since it will become extremely hot around the exhaust outlet during DPF regeneration, do not perform the regeneration in a location where fires may occur.

### Caution

Normally, set the DPF auto regeneration inhibit switch to the "Auto regeneration mode". However, when operating in a location where fires may occur, set the DPF auto regeneration inhibit switch to the "Auto regeneration inhibit mode".

### Important

When the system enters the level where DPF regeneration is required, perform the regeneration immediately. Interrupting the regeneration or ignoring the warning and continuing traveling or cutting work may cause the engine and DPF to malfunction.

### Important

If the regeneration remains uncompleted even after 30 minutes have passed since the start of automatic regeneration in PM accumulation "Level 1", PM accumulation level enters "Level 2".

- You can continue to use this machine for traveling and cutting work during DPF auto regeneration.
- You cannot continue to use this machine for traveling and cutting work during DPF parked regeneration.
- You can operate this machine to perform the regeneration. (The fault diagnostic tool is not required.)



## &lt;Automatic regeneration&gt;

■ When the DPF auto regeneration inhibit switch set to the "Auto regeneration mode":

1. When the conditions for automatic regeneration are met, the automatic regeneration starts with the regeneration icon lighting.
2. When the regeneration completed, the regeneration icon disappears.

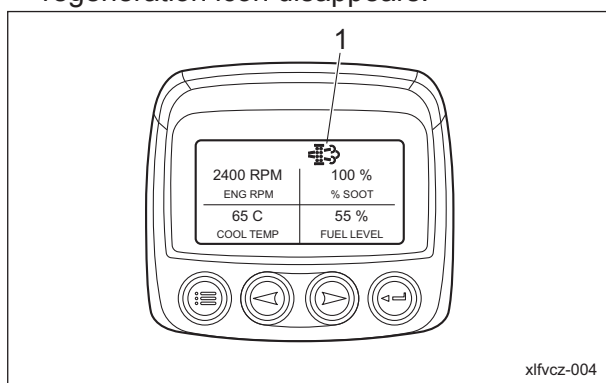

Level 1\_001

1	Regeneration icon
---	-------------------

■ When the DPF auto regeneration inhibit switch set to the "Auto regeneration inhibit mode":

1. The blinking regeneration icon appears.
2. Set the DPF auto regeneration inhibit switch to the "Auto regeneration mode".
3. When the conditions for automatic regeneration are met, the automatic regeneration starts and the regeneration icon changes from blinking to lighting.
4. When the regeneration completed, the regeneration icon disappears.

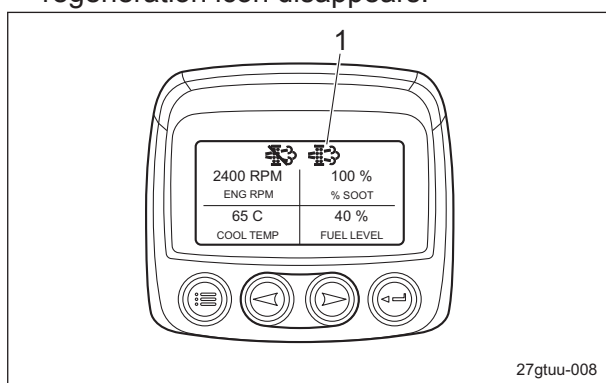

Level 1\_002

1	Regeneration icon
---	-------------------

## &lt;Parked regeneration&gt;

· These are the conditions for activating parked regeneration.

1. The parking brake is applied.
  2. The traveling pedal is in neutral.
  3. The throttle opening is 0% (idling).
1. The blinking regeneration icon appears. When the DPF auto regeneration inhibit switch set to the "Auto regeneration mode":

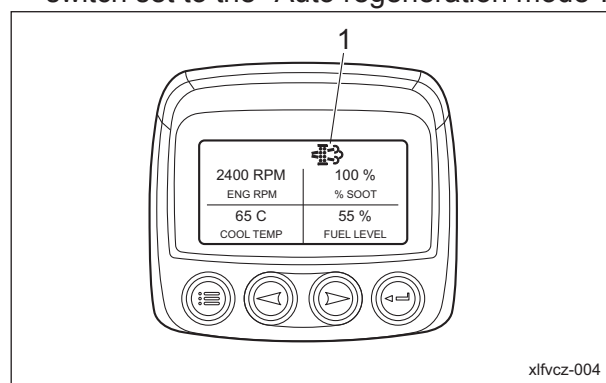

Level 1\_003

1	Regeneration icon
---	-------------------

When the DPF auto regeneration inhibit switch set to the "Auto regeneration inhibit mode":

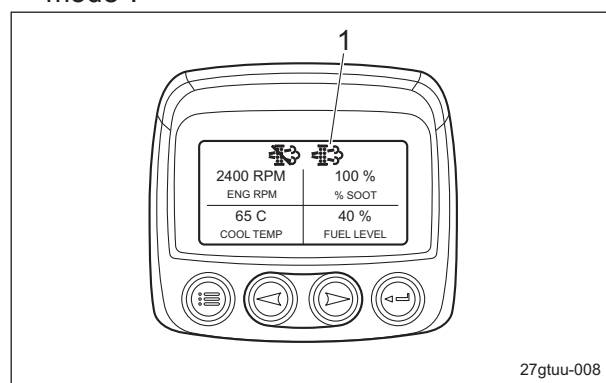

Level 1\_004

1	Regeneration icon
---	-------------------

2. Stop traveling and cutting work.
3. Park this machine in a safe location.
4. Apply the parking brake.
5. Set the throttle opening to 0% (idling).
6. Press the DPF parked regeneration switch. Parked regeneration starts and the regeneration icon changes from blinking to lighting.
7. When the regeneration completed, the regeneration icon disappears.

# Maintenance

## Level 2

### **⚠ Danger**

Since it will become extremely hot around the exhaust outlet during DPF regeneration, do not perform the regeneration in a location where fires may occur.

### **⚠ Caution**

Normally, set the DPF auto regeneration inhibit switch to the "Auto regeneration mode". However, when operating in a location where fires may occur, set the DPF auto regeneration inhibit switch to the "Auto regeneration inhibit mode".

### **Important**

When the system enters the level where DPF regeneration is required, perform the regeneration immediately.

Interrupting the regeneration or ignoring the warning and continuing traveling or cutting work may cause the engine and DPF to malfunction.

### **Important**

If ignoring the parked regeneration requirement and continuing traveling or cutting work in PM accumulation "Level 2", PM accumulation level enters "Level 3".

- You can continue to use this machine for traveling and cutting work during DPF auto regeneration.
- You can not continue to use this machine for traveling and cutting work during DPF parked regeneration.
- You can operate this machine to perform the regeneration. (The fault diagnostic tool is not required.)

#### <Automatic regeneration>

■ When the DPF auto regeneration inhibit switch set to the "Auto regeneration mode":

1. When the conditions for automatic regeneration are met, the automatic regeneration starts with the regeneration icon lighting.

2. When the regeneration completed, the regeneration icon disappears.

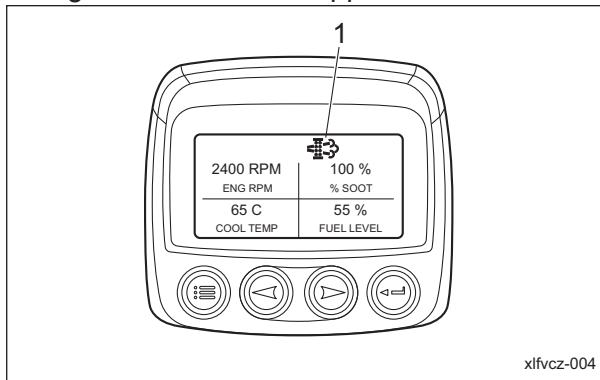

Level 2\_001

1	Regeneration icon
---	-------------------

■ When the DPF auto regeneration inhibit switch set to the "Auto regeneration inhibit mode":

1. The blinking regeneration icon appears.
2. Set the DPF auto regeneration inhibit switch to the "Auto regeneration mode".
3. When the conditions for automatic regeneration are met, the automatic regeneration starts and the regeneration icon changes from blinking to lighting.
4. When the regeneration completed, the regeneration icon disappears.

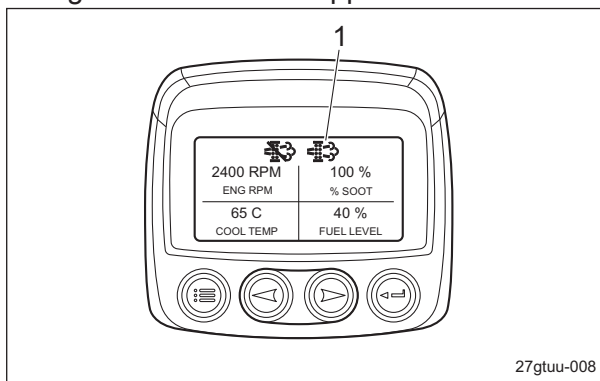

Level 2\_002

1	Regeneration icon
---	-------------------

## &lt;Parked regeneration&gt;

- These are the conditions for activating parked regeneration.
  1. The parking brake is applied.
  2. The traveling pedal is in neutral.
  3. The throttle opening is 0% (idling).
- 1. The blinking regeneration icon appears.  
When the DPF auto regeneration inhibit switch set to the "Auto regeneration mode":

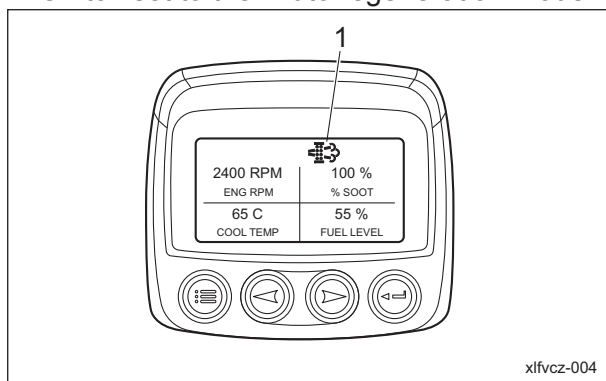

Level 2\_003

1	Regeneration icon
---	-------------------

When the DPF auto regeneration inhibit switch set to the "Auto regeneration inhibit mode":

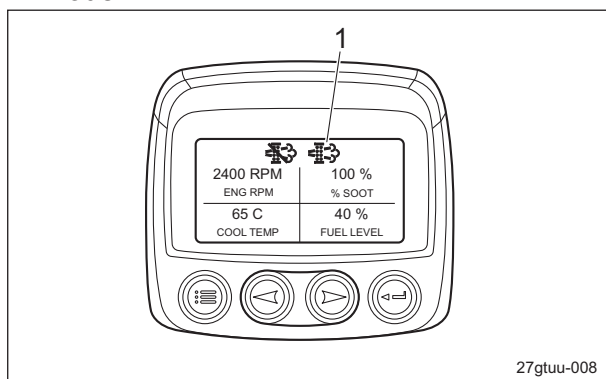

Level 2\_004

1	Regeneration icon
---	-------------------

2. Stop traveling and cutting work.
3. Park this machine in a safe location.
4. Apply the parking brake.
5. Set the throttle opening to 0% (idling).
6. Press the DPF parked regeneration switch.  
Parked regeneration starts and the regeneration icon changes from blinking to lighting.
7. When the regeneration completed, the regeneration icon disappears.

## Level 3

**⚠ Danger**

Since it will become extremely hot around the exhaust outlet during DPF regeneration, do not perform the regeneration in a location where fires may occur.

**Important**

When the system enters the level where DPF regeneration is required, perform the regeneration immediately. Interrupting the regeneration or ignoring the warning and continuing traveling or cutting work may cause the engine and DPF to malfunction.

**Important**

If ignoring the parked regeneration requirement and continuing traveling or cutting work in PM accumulation "Level 3", PM accumulation level enters "Level 4". If still continuing traveling or cutting work, you will not be able to operate this machine for regeneration.

**Important**

Automatic regeneration can not be activated in PM accumulation "Level 3". Perform parked regeneration immediately.

- You can not continue to use this machine for traveling and cutting work during DPF regeneration.
- You can operate this machine to perform the regeneration. (The fault diagnostic tool is not required.)

# Maintenance

1. These are the statuses in PM accumulation "Level 3".

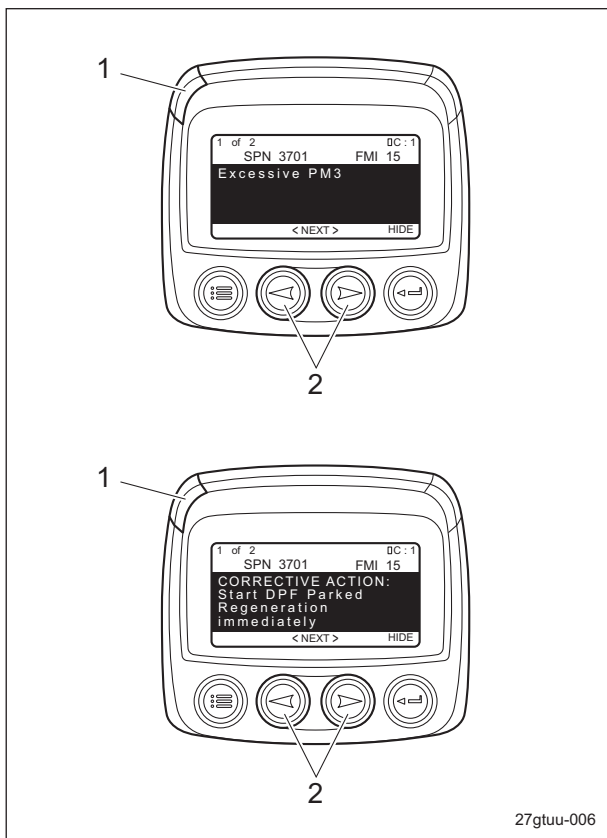

27gtuu-006

Level 3\_001

1	LED (yellow)
2	Arrow key

- "Excessive PM3" appears in the monitor display.  
Pressing an arrow key changes the display to "CORRECTIVE ACTION: Start DPF Parked Regeneration immediately".
  - The LED (yellow) lights up.
  - The engine output is limited at 50%.
2. Stop traveling and cutting work.
  3. Park this machine in a safe location.
  4. Apply the parking brake.
  5. Set the throttle opening to 0% (idling).
  6. If the DPF auto regeneration inhibit switch set to the "Auto regeneration inhibit mode," set it to the "Auto regeneration mode."
  7. Press the DPF parked regeneration switch. Parked regeneration starts and the regeneration icon changes from blinking to lighting.
  8. When the regeneration completed, the regeneration icon disappears.

## Level 4

### **! Danger**

Since it will become extremely hot around the exhaust outlet during DPF regeneration, do not perform the regeneration in a location where fires may occur.

### Important

When the system enters the level where DPF regeneration is required, perform the regeneration immediately.

Interrupting the regeneration or ignoring the warning and continuing traveling or cutting work may cause the engine and DPF to malfunction.

### Important

If ignoring the manual regeneration requirement and continuing traveling or cutting work in PM accumulation "Level 4", PM accumulation level enters "Level 5".

If still continuing traveling or cutting work, fatal trouble will occur on the engine and DPF.

- You can not continue to use this machine for traveling and cutting work during DPF regeneration.
- You can not perform the regeneration. (The fault diagnostic tool is required.)

1. These are the statuses in PM accumulation "Level 4".

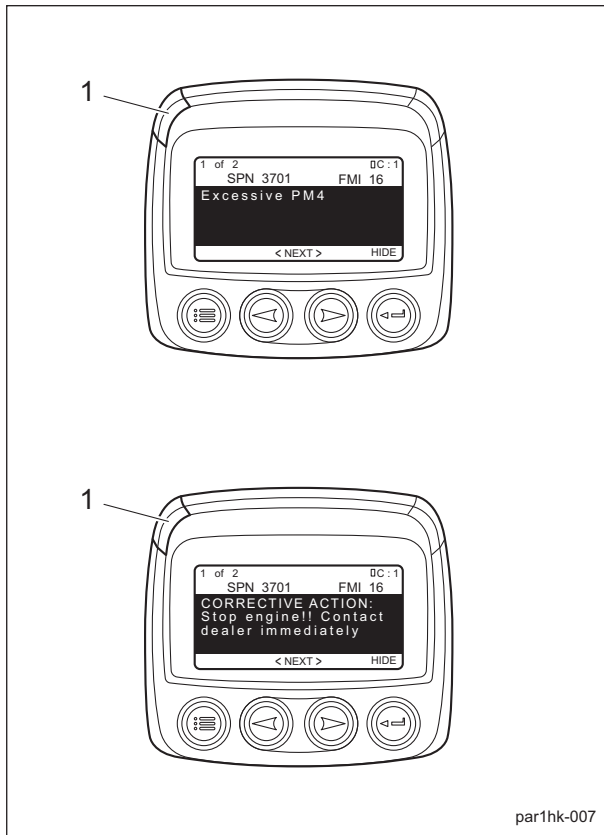

par1hk-007

Level 4\_001

1	LED (yellow)
2	Arrow key

- "Excessive PM4" appears in the monitor display.  
Pressing an arrow key changes the display to "CORRECTIVE ACTION: Stop engine!! Contact dealer immediately".
  - The LED (yellow) lights up.
  - The engine output is limited at 50%.
2. Stop traveling and cutting work.
  3. Park this machine in a safe location.
  4. Apply the parking brake.
  5. Stop the engine.
  6. Contact your dealer for manual regeneration.

Level 5

When PM accumulates excessively in the DPF or ash accumulates, replace the DPF since the regeneration in that case is prohibited.

- You can not continue to use this machine for traveling and cutting work.
- The regeneration is impossible.

1. These are the statuses in PM accumulation "Level 5".

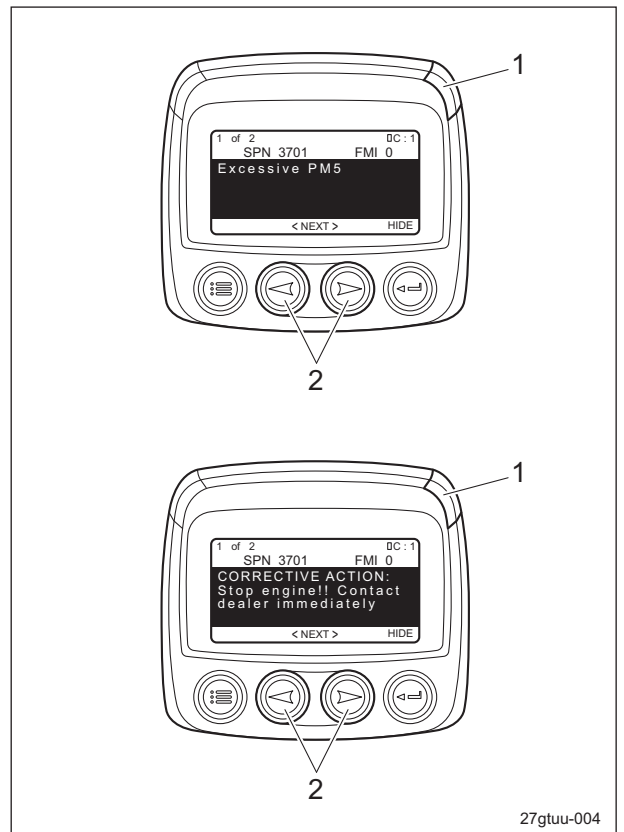

27gtuu-004

Level 5\_001

1	LED (red)
2	Arrow key

- "Excessive PM5" appears in the monitor display.  
Pressing an arrow key changes the display to "CORRECTIVE ACTION: Stop engine!! Contact dealer immediately".
  - The LED (red) lights up.
  - The engine output is limited at 50%.
2. Stop traveling and cutting work.
  3. Park this machine in a safe location.
  4. Apply the parking brake.
  5. Stop the engine.
  6. Contact your dealer for DPF replacement.

# Maintenance

## Jacking Up The Machine

### About Jacking Up The Machine

**Warning**

When replacing a tire or beginning any other maintenance or repairs, be sure to chock the wheels to prevent the machine from moving. Before jacking up the machine, park it on a hard, flat surface such as a concrete floor and remove any obstacles that could prevent you from performing the work safely. When necessary, use an appropriate chain block, hoist, or jack. Support the machine securely with jack stands or appropriate blocks. Failure to do so may cause the machine to move or fall, resulting in injury or death.

**Important**

Only place a jack under the jack-up points specified. Placing a jack at any other point will result in damage to the frame or other parts.

Use the jack-up points identified in this manual when jacking up the machine.

### Jack-Up Points

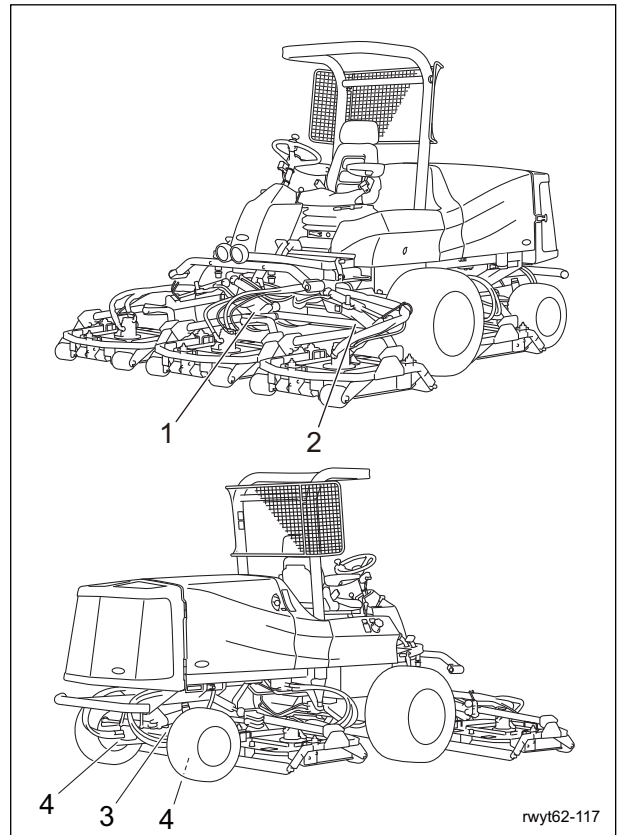

Jack-Up Points\_001

	Jack-up points
1	Front right frame
2	Front left frame
3	Center of pivot
4	Below rear wheel motors

#### 1. Front right frame

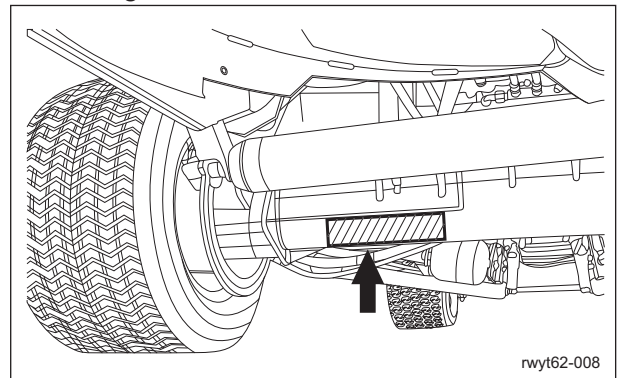

Jack-Up Points\_002



## 2. Front left frame

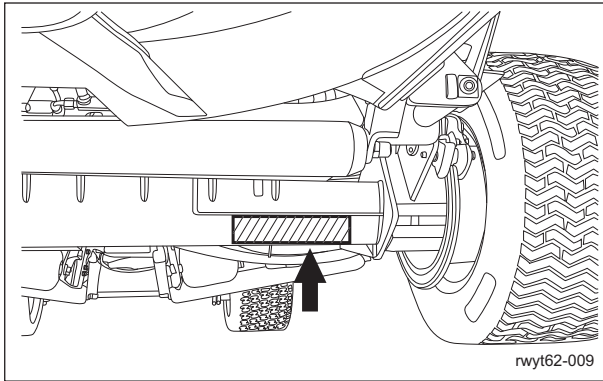

Jack-Up Points\_003

## 3. Center of pivot

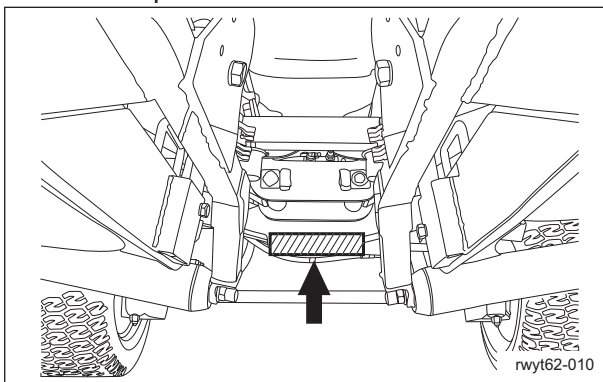

Jack-Up Points\_004

## 4. Below rear wheel motors Two locations

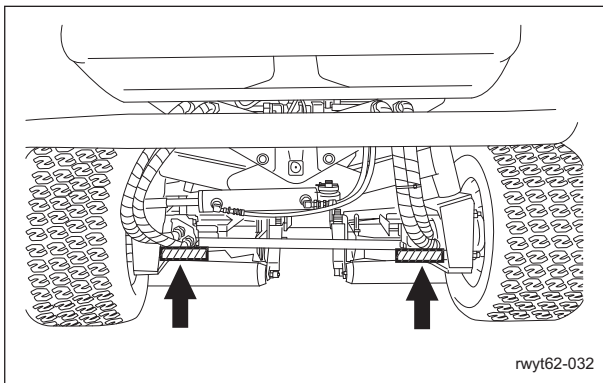

Jack-Up Points\_005

## Greasing

### About Greasing

Since there may be adhesion or damage due to lack of grease on moving parts, they must be greased.

Add urea-based No. 2 grease in accordance with the Maintenance Schedule.

Other locations where the specified grease or lubricant is used are indicated in "Greasing Points".

Add grease using the specified grease or lubricant.

### Greasing Points

Grease nipples are installed in the following locations.

Add grease every 50 hours of operation.

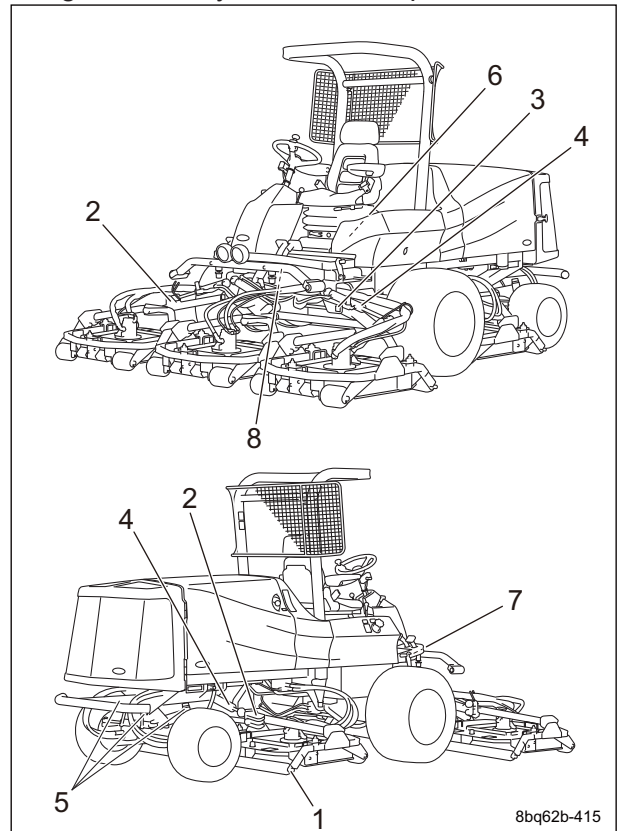

Greasing Points\_001

# Maintenance

	Portion	No. of Greasing Points
1	Rear roller	10
2	Mower arm fulcrum	5
3	Lift arm fulcrum	5
4	Lift arm cylinder fulcrum	12
5	Pivot	3
6	Neutral position area	2
7	Traveling pedal shaft fulcrum	2
8	Foot brake	3

### 1. Rear roller

There is one greasing point each on the left and right of each mower deck.

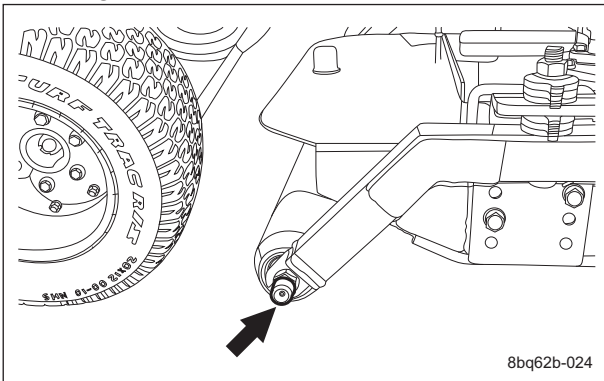

Greasing Points\_002

### 2. Mower arm fulcrum

There is one greasing point on the arm connected to each mower deck. Grease mower decks #2 and #3 in the swiveled position.

Mower decks #1, #4 and #5

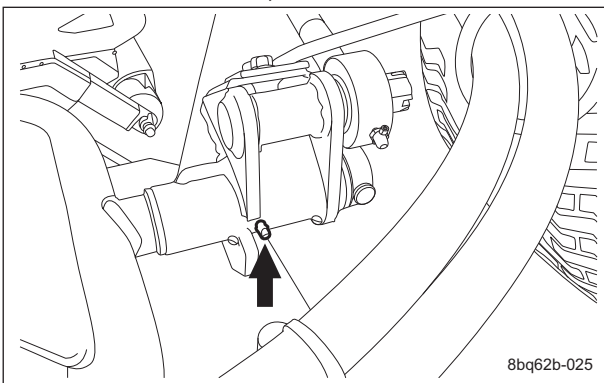

Greasing Points\_003

### Mower decks #2 and #3

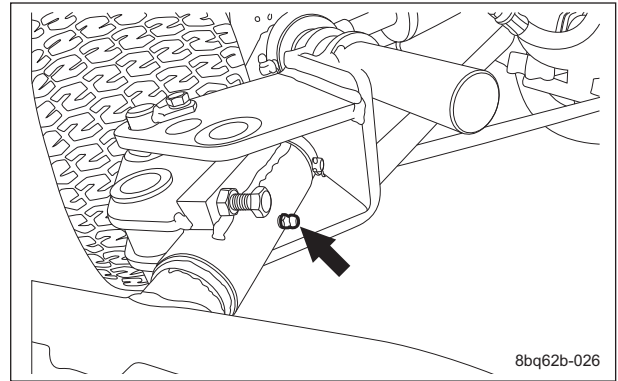

Greasing Points\_004

### 3. Lift arm fulcrum

There is one greasing point on the arm connected to each mower deck. Lower the mower decks before greasing the lift arm fulcrums.

Mower decks #1 and #4

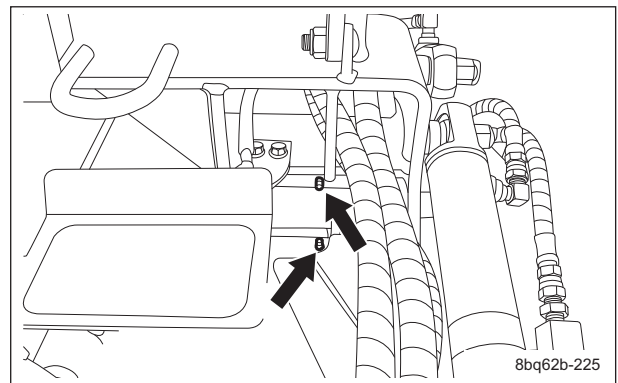

Greasing Points\_005

### Mower decks #2 and #3

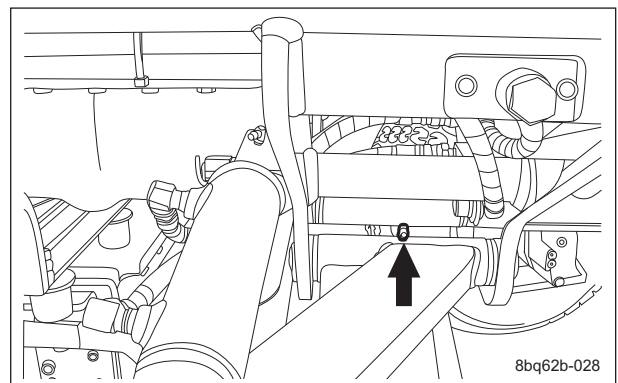

Greasing Points\_006



### Mower deck #5

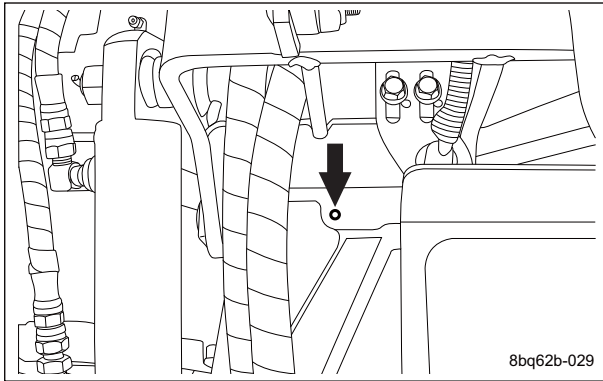

Greasing Points\_007

### 5. Pivot

Middle between the rear wheels

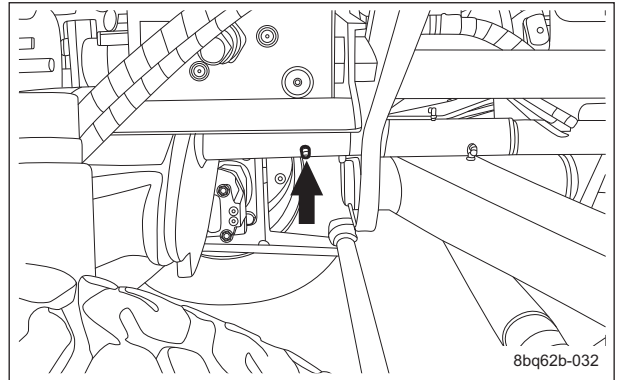

Greasing Points\_010

### 4. Lift arm cylinder fulcrum

This is on each cylinder of the arms connected to each mower deck.

Mower decks #1, #4 and #5

There are two greasing points on each cylinder.

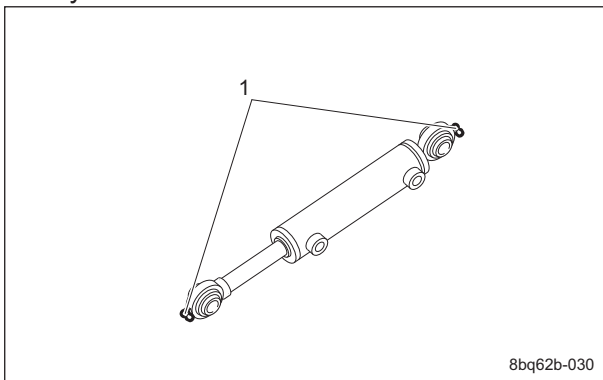

Greasing Points\_008

1	Grease nipple (2 locations)
---	-----------------------------

### Rear left wheel

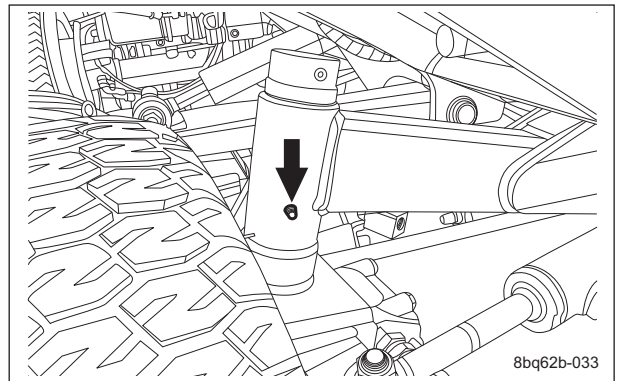

Greasing Points\_011

### Rear right wheel

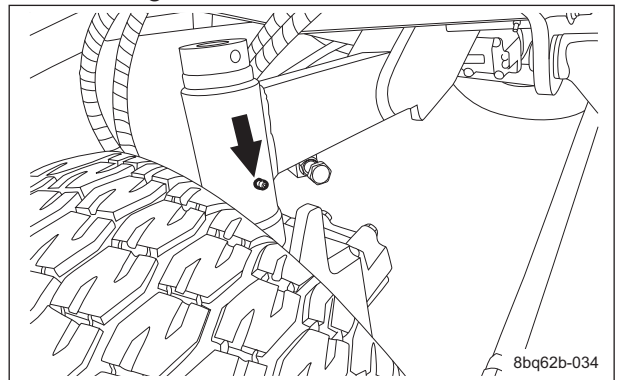

Greasing Points\_012

### Mower decks #2 and #3

There are three greasing points on each cylinder.

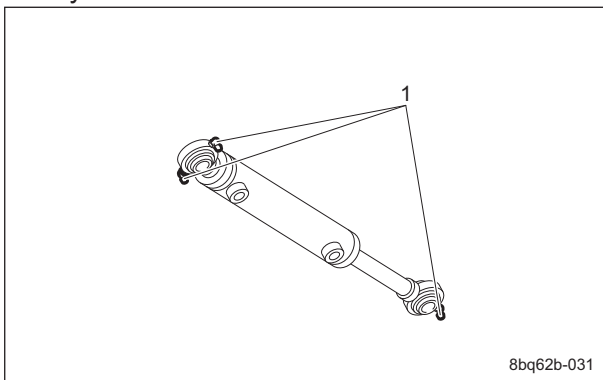

Greasing Points\_009

1	Grease nipple (3 locations)
---	-----------------------------

Maintenance

# Maintenance

**6. Neutral position area**  
There are two locations.

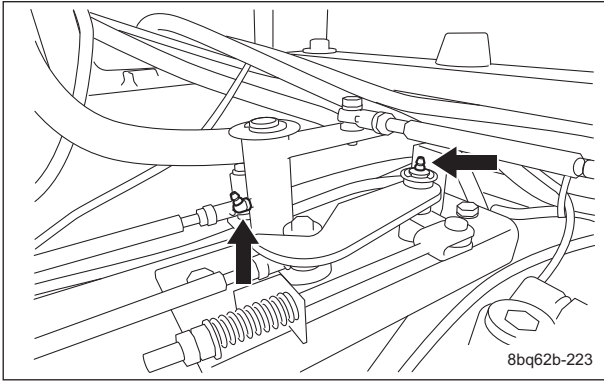

Greasing Points\_013

**7. Traveling pedal shaft fulcrum**  
There are two locations.

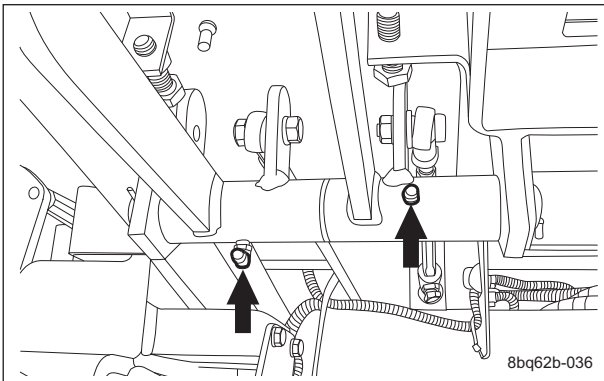

Greasing Points\_014

**8. Foot brake**  
There are three locations.

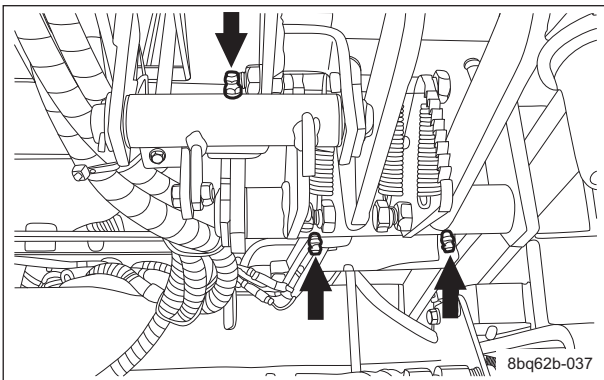

Greasing Points\_015

## Lubrication

### About Lubrication

It is necessary to lubricate moving parts so that they will not become stuck or damaged. The locations where lubricant is used are indicated in "Lubricating Points". Apply the lubricant.

### Lubricating Points

Apply lubricant at the following locations every 50 hours of operation.

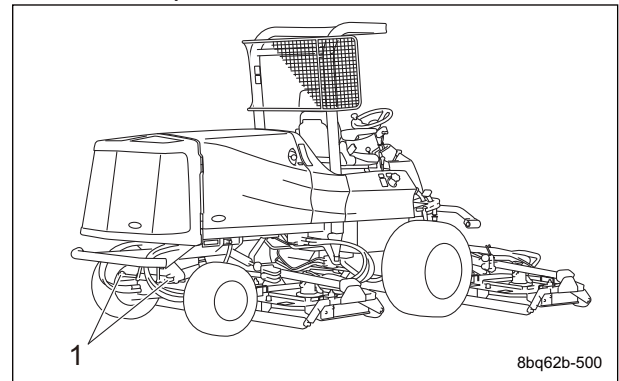

Lubricating Points\_001

	Location	No. of lubricating points
1	Steering cylinder spherical bearing	2

**1. Steering cylinder spherical bearing**  
There are two locations.

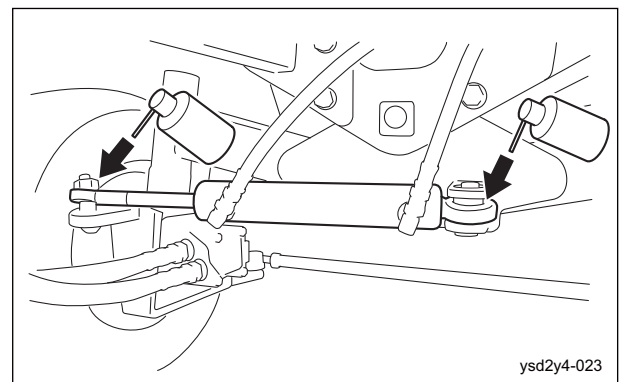

Lubricating Points\_002

## Maintenance Work

### Cleaning of Mower Deck

- Be sure to clean the mower deck after use.
1. Stop the engine, and then remove the key.
  2. Carefully clean the front and back of the mower deck with water or compressed air.
  3. Remove any grass wrapped around the rotary knife.

### Change of Rotary Knife

**Caution**

The rotary knife is an edged tool. Take extra care in handling since they could cut your hands or legs.

**Caution**

If the rotary knife becomes worn or damaged, a crack or tear between the sail and flat part will result. Take extra care since a broken piece of the rotary knife may fly off while it is rotating.

**Caution**

When touching edged tools, wear gloves, since they could cut your hands.

**Important**

The rotary knife has a specific installation direction. Do not install it facing the wrong direction.

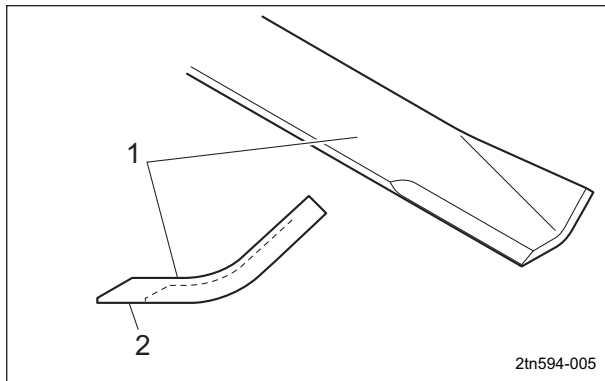

Change of Rotary Knife\_001

1	Rotary knife top side
2	Rotary knife bottom side

**Important**

Before installing the rotary knife, make sure that it is balanced.

If the edge of the rotary knife becomes chipped or thin, replace it with a new one. The criteria for replacing the rotary knife are described below.

1. When the narrowest part of the rotary knife has a width of less than 2/3 of the width of a new knife

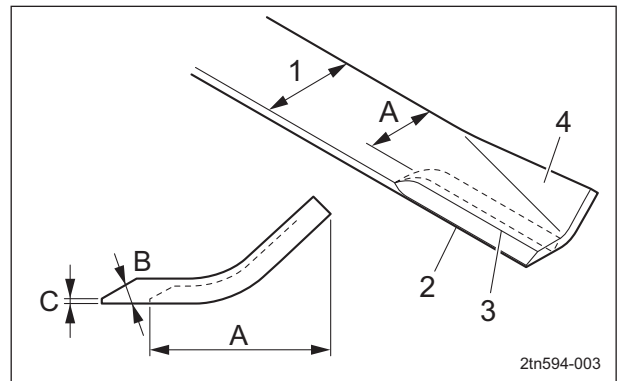

Change of Rotary Knife\_002

1	Total width
2	Blade edge
3	Blade base
4	Sail
A	less than 2/3
B	30 - 40°
C	0.5 - 1.0 mm (0.02 - 0.04 in)

2. When the thinnest part of the rotary knife has a thickness of less than 1/3 of the thickness of a new knife

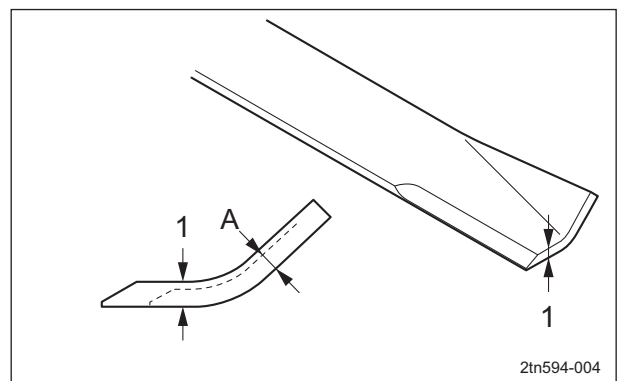

Change of Rotary Knife\_003

1	Thickness
A	less than 1/3

# Maintenance

## Mower Deck #1

1. Start the engine, and then raise the mower decks.
2. Stop the engine, and then remove the key.
3. Lift the mower deck at the front.

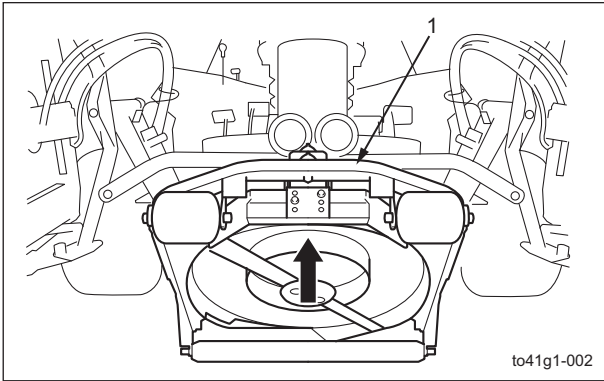

Mower Deck #1\_001

1	Mower deck
---	------------

4. Remove the cotter pin and hardened roundhead pin inserted at a, and then insert them at b.

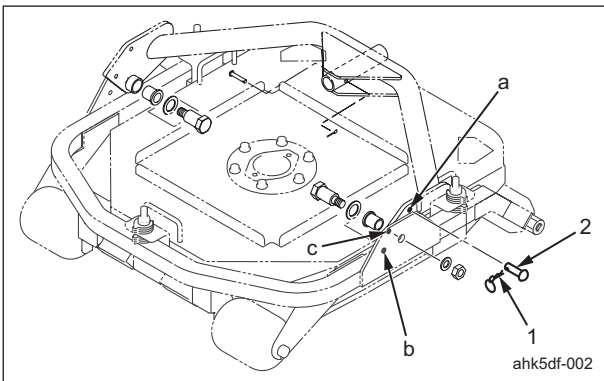

Mower Deck #1\_002

1	Cotter pin
2	Hardened roundhead pin

5. Follow the steps below to remove the rotary knife.

- [1] Use the square pipe from the included tools to secure the rotary knife so that it does not turn.
- [2] Remove the two bolts, spring washers and washers used to install the rotary knife.
- [3] Remove the knife guide.

- [4] Remove the rotary knife.

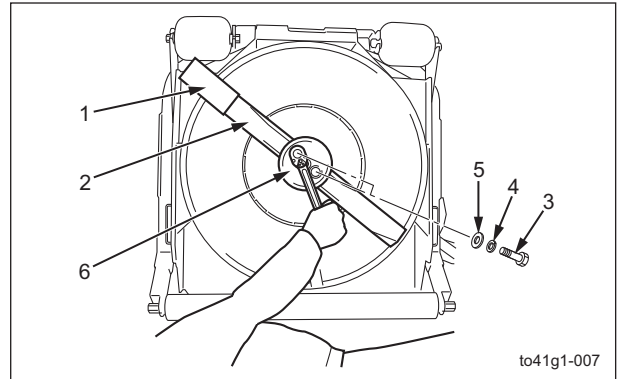

Mower Deck #1\_003

1	Square pipe
2	Rotary knife
3	Bolt
4	Spring washer
5	Washer
6	Knife guide

### Important

The tightening torque for the knife mounting bolt is 104 - 134 N-m (1,060.49 - 1,366.40 kgf-cm).

6. Install the rotary knife.  
For installing the rotary knife, reverse the removing procedure.

## Mower Decks #2/#3

1. Remove the clip pin installed on the mower arm, and then pull out the grip pin.

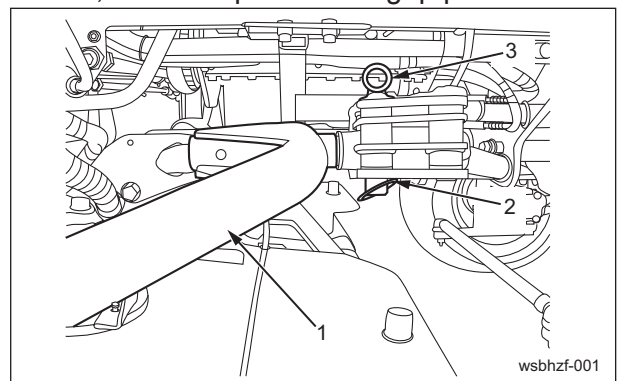

Mower Decks #2/#3\_001

1	Mower arm
2	Clip pin
3	Grip pin

2. Pull out the mower deck.

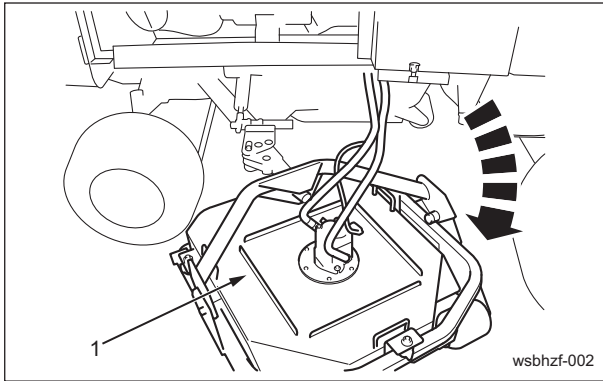

Mower Decks #2/#3\_002

1	Mower deck
---	------------

3. Install the grip pin and clip pin in the mounting hole for maintenance.

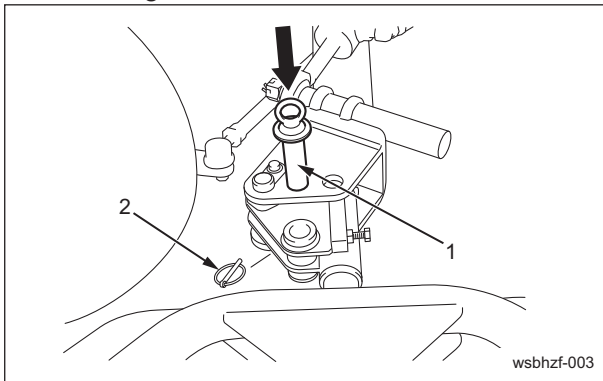

Mower Decks #2/#3\_003

1	Grip pin
2	Clip pin

4. Start the engine, and then raise the mower decks.

5. Stop the engine, and then remove the key.

6. Lift the mower deck at the front.

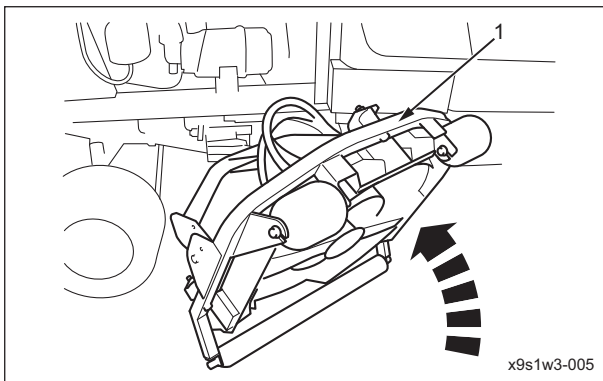

Mower Decks #2/#3\_004

1	Mower deck
---	------------

7. Remove the cotter pin and hardened roundhead pin inserted at a, and then insert them at b.

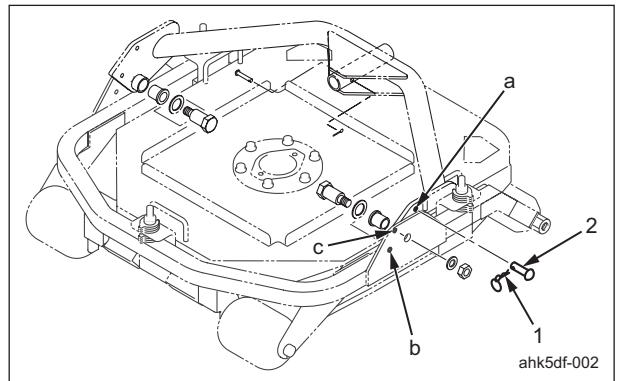

Mower Decks #2/#3\_005

1	Cotter pin
2	Hardened roundhead pin

8. Follow the steps below to remove the rotary knife.

[1] Use the square pipe from the included tools to secure the rotary knife so that it does not turn.

[2] Remove the two bolts, spring washers and washers used to install the rotary knife.

[3] Remove the knife guide.

[4] Remove the rotary knife.

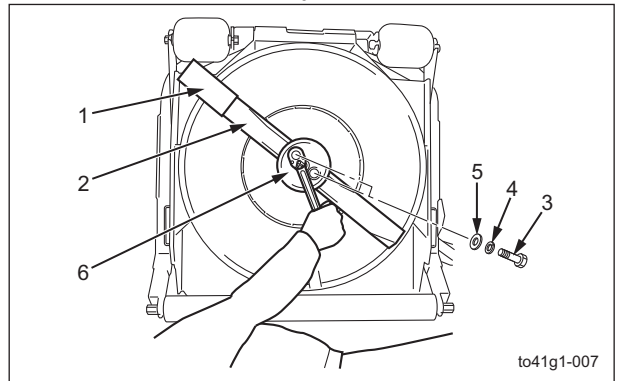

Mower Decks #2/#3\_006

1	Square pipe
2	Rotary knife
3	Bolt
4	Spring washer
5	Washer
6	Knife guide

Maintenance

# Maintenance

**Important**

The tightening torque for the knife mounting bolt is 104 - 134 N-m (1,060.49 - 1,366.40 kgf-cm).

9. Install the rotary knife.  
For installing the rotary knife, reverse the removing procedure.

**Mower Decks #4/#5**

1. Start the engine, and then raise the mower decks.

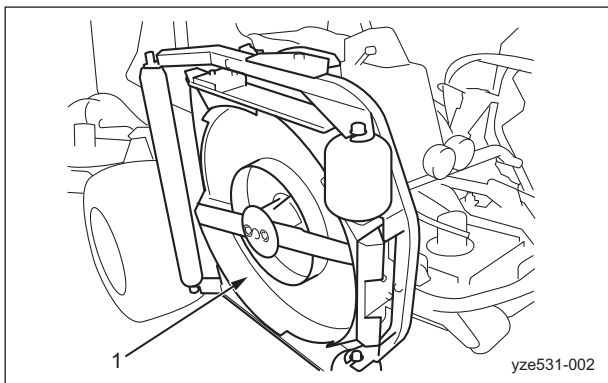

Mower Decks #4/#5\_001

1	Mower deck
---	------------

2. Stop the engine, and then remove the key.
3. Remove the cotter pin and hardened roundhead pin inserted at a, and then insert them at c.

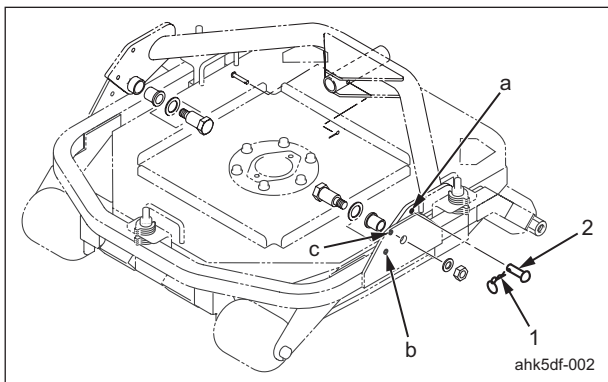

Mower Decks #4/#5\_002

1	Cotter pin
2	Hardened roundhead pin

4. Follow the steps below to remove the rotary knife.

[1] Use the square pipe from the included tools to secure the rotary knife so that it does not turn.

- [2] Remove the two bolts, spring washers and washers used to install the rotary knife.

[3] Remove the knife guide.

[4] Remove the rotary knife.

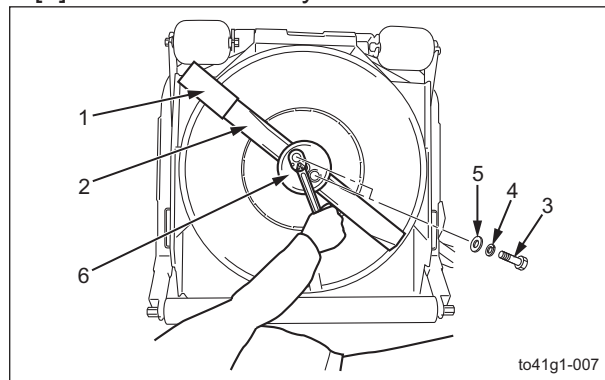

Mower Decks #4/#5\_003

1	Square pipe
2	Rotary knife
3	Bolt
4	Spring washer
5	Washer
6	Knife guide

**Important**

The tightening torque for the knife mounting bolt is 104 - 134 N-m (1,060.49 - 1,366.40 kgf-cm).

5. Install the rotary knife.  
For installing the rotary knife, reverse the removing procedure.



## Grinding of Rotary Knife

### ⚠ Caution

The rotary knife is an edged tool. Take extra care in handling since they could cut your hands or legs.

### ⚠ Caution

Wear gloves when touching edged tools to avoid cutting your hands.

### ⚠ Caution

If the rotary knife becomes worn or damaged, a crack or tear between the sail and flat part will result. Take extra care since a broken piece of the rotary knife may fly off while it is rotating.

### ⚠ Caution

When grinding the rotary knife, be sure to wear safety glasses and gloves.

### Important

Using an imbalanced rotary knife will cause vibrations, resulting in damage to the machine.

When the edge of the rotary knife becomes rounded and no longer cuts well, sharpen the worn cutting edge with a grinder or sander. If the edge of the rotary knife becomes chipped or thin, replace it with a new one.

The criteria for grinding the rotary knife is described below.

1. When, after grinding, the width of the rotary knife to the blade edge is  $\frac{2}{3}$  or more of the total width of a new knife

2. When, after grinding, the blade base of the rotary knife does not reach the sail

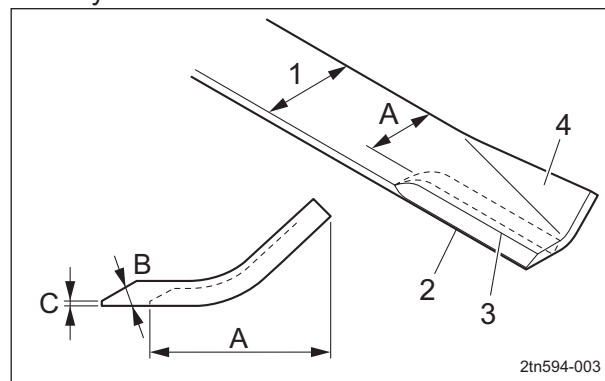

Grinding of Rotary Knife\_001

1	Total width
2	Blade edge
3	Blade base
4	Sail
A	$\frac{2}{3}$ or more
B	30 - 40°
C	0.5 - 1.0 mm (0.02 - 0.04 in)

3. When the thinnest part of the rotary knife has a thickness of  $\frac{1}{3}$  or more of the thickness of a new knife

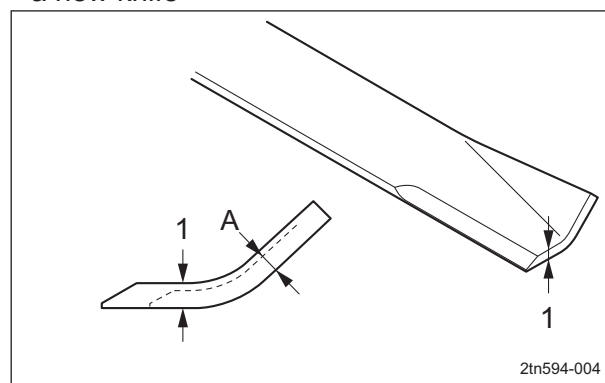

Grinding of Rotary Knife\_002

1	Thickness
A	$\frac{1}{3}$ or more

# Maintenance

Follow the steps below to grind the rotary knife.

1. Remove the rotary knife from the mower deck.

"Change of Rotary Knife" (Page 5-25)

**Important**

Grind only the top surface of the edge, and be sure to maintain the original angle.

By equally grinding the left and right ends of the rotary knife, it can be sharpened without becoming imbalanced.

2. Grind the cutting edge of the rotary knife. Grind so that the edge angle is 30 - 40 degrees, the point thickness is 0.5 - 1.0 mm (0.02 - 0.04 in), and the blade base does not reach the sail.

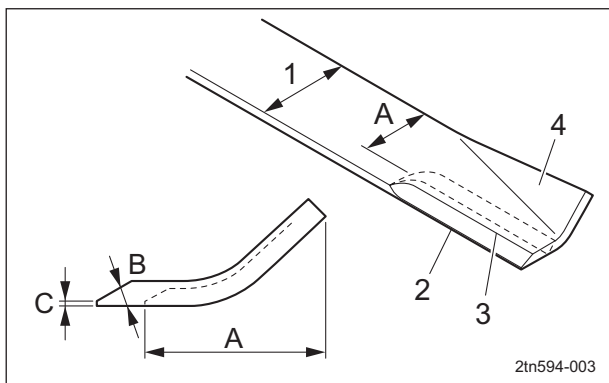

Grinding of Rotary Knife\_003

1	Total width
2	Blade edge
3	Blade base
4	Sail
A	2/3 or more
B	30 - 40°
C	0.5 - 1.0 mm (0.02 - 0.04 in)

3. Balance the rotary knife. "Balancing of Rotary Knife" (Page 5-30)
4. If it is not balanced, repeat steps 2. - 3.

## Balancing of Rotary Knife

**Caution**

The rotary knife is an edged tool. Take extra care in handling since they could cut your hands or legs.

**Caution**

When touching edged tools, wear gloves, since they could cut your hands.

**Important**

Using an imbalanced rotary knife will cause vibrations, resulting in damage to the machine.

When the rotary knife is worn asymmetrically, causing vibrations, or when it becomes dull or worn, remove the rotary knife from the mower deck and balance it.

Follow the steps below to balance the rotary knife.

1. Remove the rotary knife from the mower deck. "Change of Rotary Knife" (Page 5-25)
2. Install the balancer equipment in an appropriate location.
3. Fit the hole at the center of the rotary knife onto the balancer equipment, and then balance the left and right ends so that the rotary knife is level.

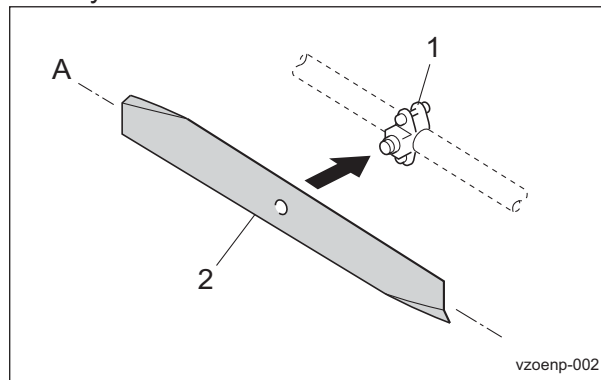

Balancing of Rotary Knife\_001

1	Balancer equipment
2	Rotary knife
A	Level



## Removing/Installing Tires

1	Rear tire
2	Heat-treated bolt

### Front Tires

Follow the steps below to remove the front tires:

1. Loosen the bolts.

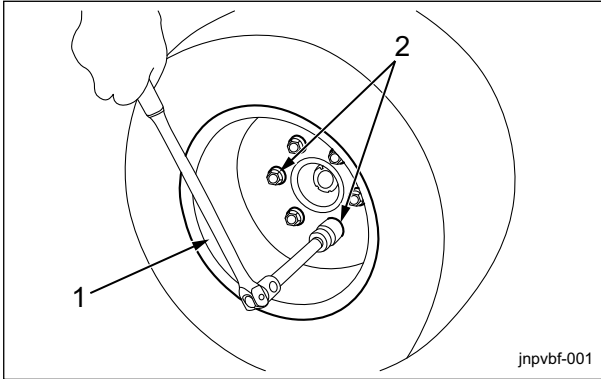

Front Tires\_001

1	Front tire
2	Heat-treated bolt

2. Securely place the jack beneath the jack-up point of the front left/right frame area, and then raise it until the tire lifts off the ground. "Jack-Up Points" (Page 5-20)
3. Remove the bolts.
4. Remove the tire from the wheel mounting seat.

**Important**

Tighten the bolts in the tightening order (crosswise).

For installing the front tires, reverse the removing procedure.

### Rear Tire

Follow the steps below to remove the rear tire.

1. Loosen the bolts.

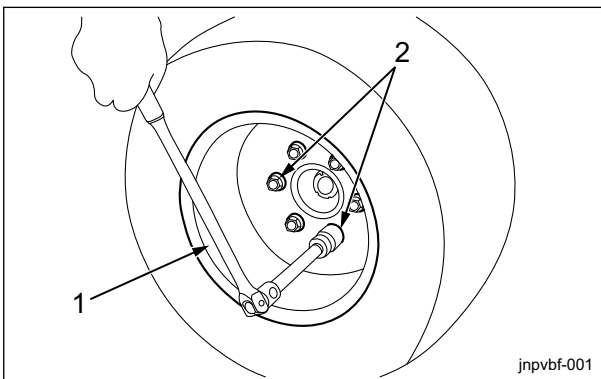

Rear Tire\_001

2. Securely place the jack beneath the jack-up point below the rear wheel motor, and then raise it until the tire lifts off the ground. "Jack-Up Points" (Page 5-20)
3. Remove the bolts.
4. Remove the tire from the wheel mounting base.

**Important**

Tighten the bolts in the tightening order (diagonally).

For installing the rear tire, reverse the removing procedure.

# Maintenance

## Adjustment of Belt Tension

**Warning**

Be sure to stop the engine before adjusting the belts.

**Important**

Before making sure of belt tension, rotate the belt several times.

If the belt becomes slack due to frequent use, it may jump or slip.

In addition, if it is overtightened, it may wear prematurely.

If necessary, adjust it, and always check the belt for appropriate tension.

### Fan Belt

1. Press the middle of the belt with your finger to check the belt tension.  
The belt tension is appropriate when the belt slacks by approximately 7.0 - 9.0 mm (0.28 - 0.35 in) when you apply a force of 98 N (10 kgf) to the belt at the middle point between the pulleys.
2. If the belt tension is inappropriate, loosen bolts A and B (that affix the alternator), and then move the alternator to adjust the tension.

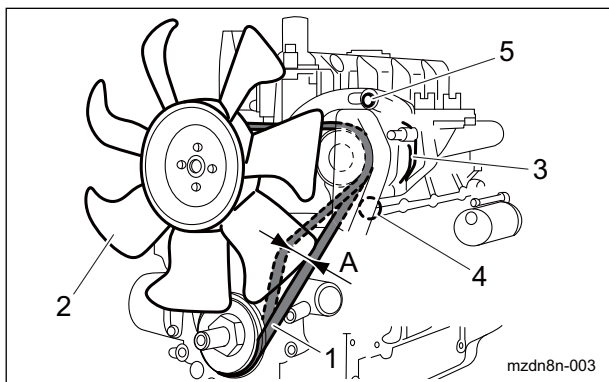

Fan Belt\_001

1	Fan belt
2	Blade
3	Alternator
4	Bolt A
5	Bolt B
A	7.0 - 9.0 mm (0.28 - 0.35 in)

## Adjustment of Brake

**Caution**

Make sure that the brake wire is not cracked or damaged.

**Important**

If the brake is not sufficiently effective due to a larger clearance between the brake disc and the pad, adjust the clearance.

The wire is used for fine adjustments.

**Important**

Adjust the brake with the brake pads.

The brake pad wear limit is 3.0 mm (0.12 in).



Adjustment of Brake\_001

1	Brake disc
2	Brake pad

**Important**

Make sure that the lever is maintained in the open position (neutral).

1. For each wheel, fully tighten the adjustment bolt on the brake disc side.

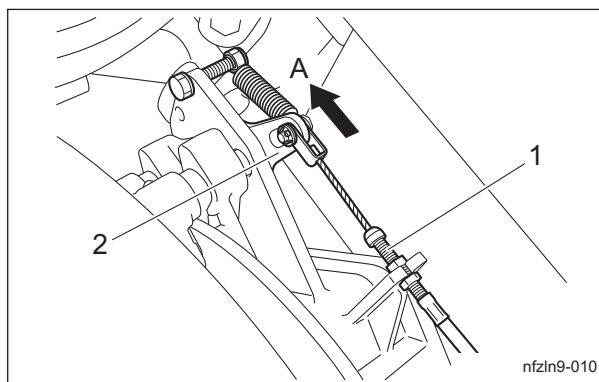

Adjustment of Brake\_002

1	Adjustment bolt (on brake disc side)
2	Lever
A	Open (neutral)

2. Reduce the clearance by loosening the lock nut, then tightening the adjustment nut. Tighten the adjustment nut until the friction material contacts the friction surface of the disc.

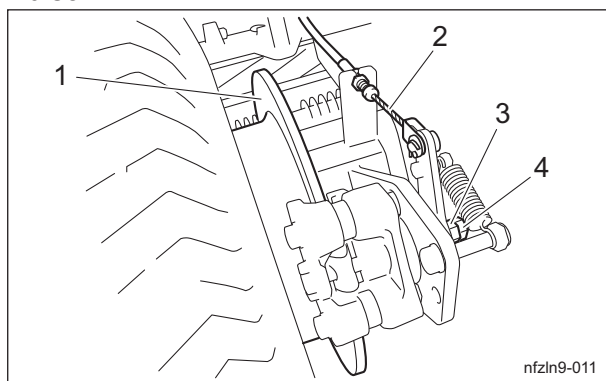

Adjustment of Brake\_003

1	Brake disc
2	Wire
3	Adjustment nut
4	Lock nut

**Warning**

A clearance between the brake disc and the pad that is too small may result in heat generation or fire.

3. Loosen the adjustment nut to adjust the clearance between the brake disc and the pad to about 0.2 mm (0.0079 in).
4. Securely place the jack beneath the jack-up point of the front left/right frame area, and then raise it until both tires lift off the ground.
5. Check that the disc rotates freely.
6. Tighten the lock nut, and then fully tighten it while holding the adjustment nut in place.

7. With the brake pedal released, obtain a play of 1.0 mm (0.039 in) at the connection of the inner wire.

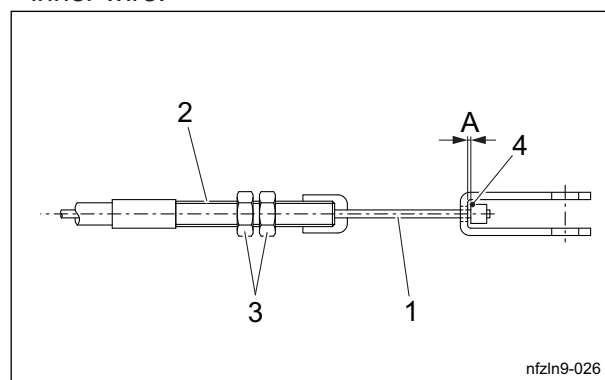

Adjustment of Brake\_004

1	Inner wire
2	Adjustment bolt
3	Lock nut
4	Connection
A	1.0 mm (0.039 in)

8. Use a wrench to loosen the lock nut and tighten it after making the adjustment with the adjustment bolt.
9. Drive, and then check the following.
  - Make sure that heat is not generated in the brake area.
  - Make sure that the left and right brakes are equally effective.

**Caution**

It may result in an unexpected accident if the left and right brakes are not equally effective.

10. If the left and right brakes are not equally effective, make fine adjustments with the adjustment bolt on the brake wire.

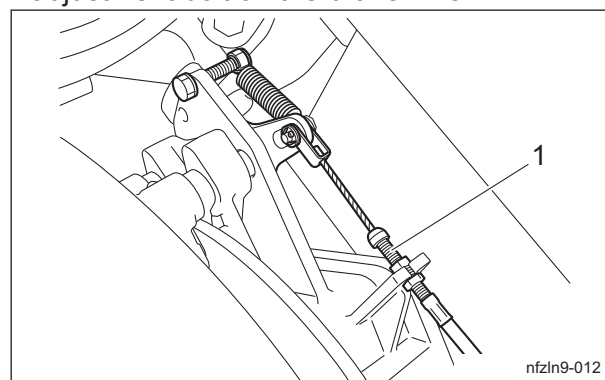

Adjustment of Brake\_005

1	Adjustment bolt (on brake disc side)
---	--------------------------------------

# Maintenance

## Break-In of Brakes

If the brake shoes or brake pads are worn, replace them with new ones.

Immediately after replacement, drive to break in the brakes if the effectiveness of the brakes is low.

While driving, lightly operate the brakes to break in the contact areas.

## Adjusting the Neutral Position of the Piston Pump

### ⚠ Caution

Make sure not to touch rotating tires.

### ⚠ Caution

When adjusting the neutral position, pay close attention to abrupt start of the machine. Place the jacks beneath the jack-up points, and then lift the machine until all the tires get off the ground.

If the machine moves forward or backward while the traveling pedals are released, they are not set to the neutral position.

Follow the steps below to make adjustments.

1. Stop the engine.
2. Place the jacks beneath the jack-up points, and then lift the machine off the ground.
3. Make sure that no tires come into contact with the jack stand.
4. Open the underseat cover.  
"Underseat Cover" (Page 4-36)
5. Start the engine, and rev it up to the maximum rpm.
6. Set the 2WD/4WD selector switch to the "2WD" position.
7. Adjust the neutral position.

[1] If the front tires rotate forward, loosen the lock nuts, and then turn the neutral adjustment rod to shorten it.

[2] If the front tires rotate in reverse, loosen the lock nuts, and then turn the neutral adjustment rod to extend it.

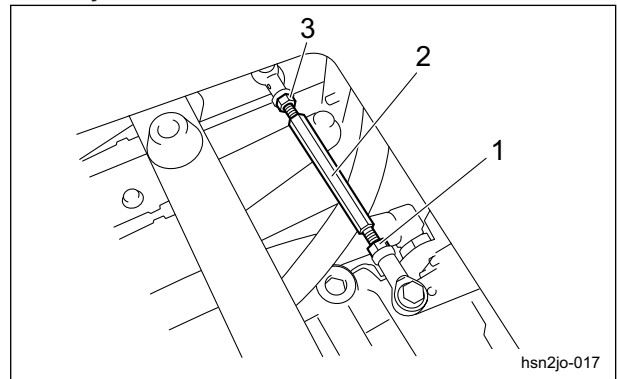

Adjusting the Neutral Position of the Piston Pump\_002

1	Lock nut A (Left-hand thread)
2	Neutral adjustment rod
3	Lock nut B (Right-hand thread)

8. Find the position where the front wheels stop, and then tighten the lock nuts.

## Change of Coolant

**⚠ Caution**

Do not touch the radiator or coolant during engine operation or immediately after the engine has been turned off. Otherwise, you may get burned.

**⚠ Caution**

Change coolant after the engine has well cooled down.

**⚠ Caution**

The radiator cap is pressurized. If you remove the radiator cap while the engine is overheated, hot steam will burst out, possibly resulting in burns. Make sure that the water temperature and pressure are reduced, and then grab the cap with a thick cloth and gradually open the cap.

**Important**

When changing the coolant, be sure to drain it into a container and discard it in accordance with local laws and regulations.

**Important**

When changing the coolant, be sure to mix clean water and antifreeze (long-life coolant), and then pour it into the radiator and reserve tank.

**Important**

Tightly close the radiator cap. If the cap is loose or incorrectly installed, the engine will be overheated due to water leakage, resulting in engine damage.

When mixing antifreeze and clean water, refer to "Relationship between concentration of long-life coolant (LLC) and freezing temperature" below for the mixing ratio.  
Relationship between concentration of long-life coolant (LLC) and freezing temperature

Freezing temperature	LLC concentration (volume %)
Down to -10 °C (14 °F)	20 %
Down to -15 °C (5 °F)	30 %
Down to -20 °C (-4 °F)	35 %
Down to -25 °C (-13 °F)	40 %

1. Stop the engine, and then allow the radiator to cool.
2. Open the hood.
3. Follow the steps below to drain the coolant.
  - [1] Position a container to drain the coolant into.
  - [2] Remove the drain plug from the radiator.

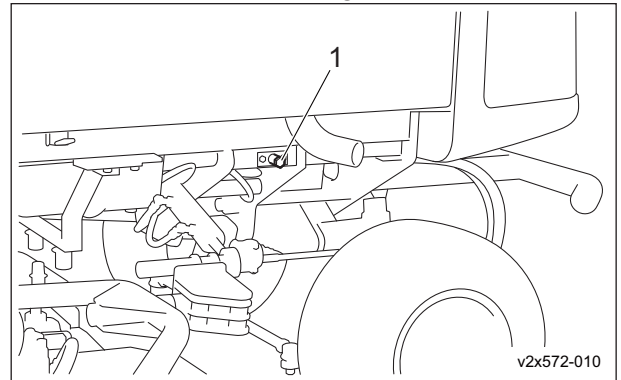

Change of Coolant\_001

1	Radiator drain plug
---	---------------------

- [3] Remove the radiator cap.

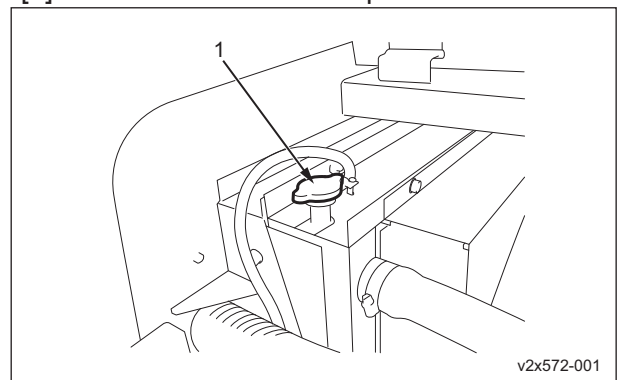

Change of Coolant\_002

1	Radiator cap
---	--------------

# Maintenance

[4] Remove the reserve tank.

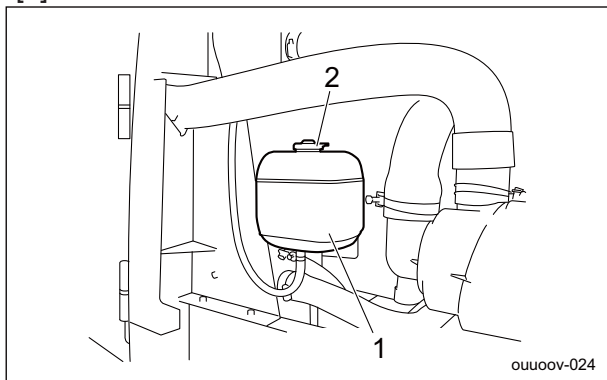

Change of Coolant\_003

1	Reserve tank
2	Reserve tank cap

[5] Open the reserve tank cap, and then drain the coolant.

4. Install the reserve tank.
5. Clean the radiator with clean water to remove any debris or rust.
6. Drain all water from the radiator.
7. Follow the steps below to fill with coolant. The coolant quantity, including the reserve tank, is 12.0 dm<sup>3</sup> (12.0 L).
  - [1] Install the drain plug.
  - [2] Supply clean water and antifreeze into the radiator up to the radiator cap opening.
  - [3] Close the radiator cap.
  - [4] Supply clean water and antifreeze into the reserve tank up to the "FULL" mark.
  - [5] Close the reserve tank cap.
8. Start the engine, and then idle for several minutes to bleed air from the system.
9. Stop the engine, and then allow the radiator to cool.
10. Check if the coolant level in the reserve tank is between "FULL" and "LOW", and then supply coolant if necessary.
11. Close the hood.

## Change of Hydraulic Oil

### ⚠ Caution

Be careful with hot oil, which could cause burns if it contacts your skin.

### Important

When you change the hydraulic oil, be sure to drain it into a bowl and discard it in accordance with local laws and regulations.

### Important

If the oil emulsifies or if it becomes even slightly less transparent, change the oil immediately.

### Important

Use Shell Tellus S2M46 (or equivalent) as hydraulic oil. In case of an equivalent, consult Characteristics of Hydraulic Oil and use hydraulic oil whose characteristics are superior to those of the specific hydraulic oil. Especially regarding kinematic viscosity and viscosity index, use of hydraulic oil whose figures are less than those of the specified hydraulic oil will cause a malfunction in the hydraulic circuit.

### Note:

#### Characteristics of Hydraulic Oil

Specified Hydraulic Oil		Shell Tellus S2M46
ISO Viscosity Grade		ISO VG46
Density	15 °C (59 °F)	0.873 g/cm <sup>3</sup> (0.0315 lb/in <sup>3</sup> )
API Gravity		30.6
Flash Point (Open Cup)		230 °C (446 °F)
Pour Point		-30 °C (-22 °F)
Kinematic	40 °C (104 °F)	46 mm <sup>2</sup> /s (46 cSt)
Viscosity	100 °C (212 °F)	7 mm <sup>2</sup> /s (7 cSt)
Viscosity Index		109

1. Follow the steps below to remove the old oil.
  - [1] Start and run the engine to warm up the oil.
  - [2] On a level surface, lower the mower decks, and then stop the engine.

[3] Remove the drain plug of the hydraulic tank, and then drain the old oil into a container.

[4] Wind new sealing tape on the drain plug, and then attach it to the hydraulic tank.

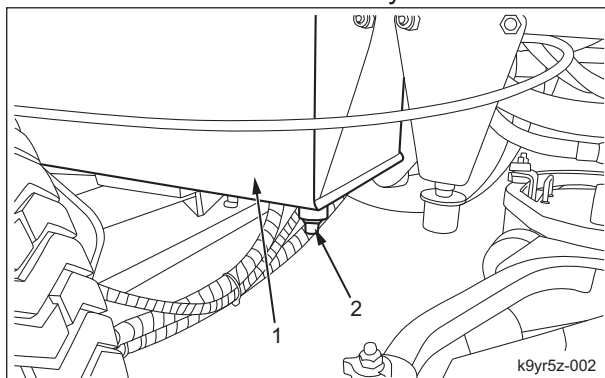

Change of Hydraulic Oil\_001

1	Hydraulic tank
2	Drain plug

2. Remove the left tank cover.

3. Open the tank cap, and then pour new oil from the fill port until the oil level reaches the middle of the oil gauge on the hydraulic tank. The hydraulic tank capacity is approximately 44.0 dm<sup>3</sup> (44.0 L).

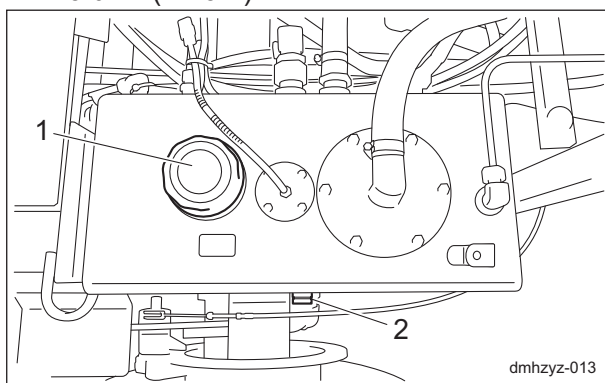

Change of Hydraulic Oil\_002

1	Tank cap
2	Oil gauge

4. Tighten the tank cap securely.

5. Start the engine, raise and lower the mower decks, and turn the steering wheel left and right.

Move forward and reverse repeatedly several times.

6. Raise the mower decks and maintain that position on a level surface, and then check to see if the oil level is at the middle of the oil gauge. If necessary, supply oil.

7. Check underneath the machine for oil leakage.

8. Attach the left tank cover.

## Change of Hydraulic Oil Filter

### Change of Hydraulic Oil Line Filter

#### ⚠ Caution

Be careful with hot oil, which could cause burns if it contacts your skin.

#### Important

When replacing the hydraulic oil filter, be sure to drain the oil into a container and discard it in accordance with local laws and regulations.

#### Important

If the hydraulic oil emulsifies or if it becomes even slightly less transparent, change the oil immediately.

#### Important

Use Shell Tellus S2M46 (or equivalent) as hydraulic oil.

1. On a level surface, lower the mower decks, and then stop the engine.

2. Remove the filter protection plate.

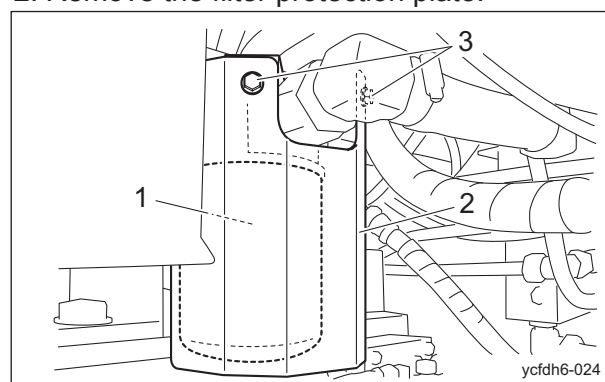

Change of Hydraulic Oil Line Filter\_001

1	Filter cartridge
2	Filter protection plate
3	Bolt

3. Loosen the old filter cartridge by hand and remove it.

4. Lightly coat the packing of the new filter cartridge with hydraulic oil, and then install the cartridge.



# Maintenance

- Firmly tighten the filter cartridge by hand until the packing contacts the mounting surface.  
And then tighten it with a half more turn.

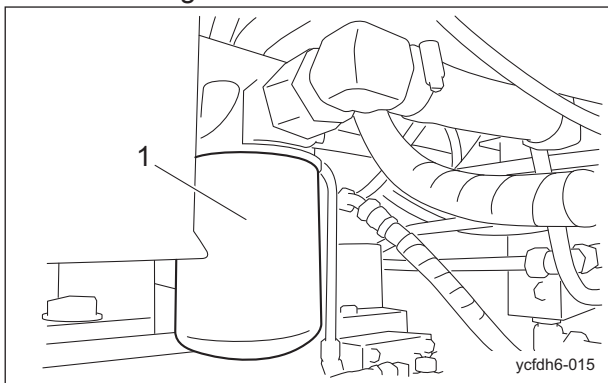

Change of Hydraulic Oil Line Filter\_002

1	Filter cartridge
---	------------------

- Supply hydraulic oil until it reaches the specified level.  
"Hydraulic Oil Supply" (Page 4-5)
- Start the engine and stop it after hydraulic oil warmed.
- Check underneath the machine for hydraulic oil leakage.
- Install the filter protection plate.

## Change of Hydraulic Oil Suction Filter

**Caution**

Be careful with hot oil, which could cause burns if it contacts your skin.

**Important**

When replacing the hydraulic oil filter, be sure to drain the oil into a container and discard it in accordance with local laws and regulations.

**Important**

If the hydraulic oil emulsifies or if it becomes even slightly less transparent, change the oil immediately.

**Important**

Use Shell Tellus S2M46 (or equivalent) as hydraulic oil.

**Important**

Replace the intake port packing with a new one.

- On a level surface, lower the mower decks, and then stop the engine.
- Remove the left tank cover.
- Remove bolts, spring washers and washers, and then remove the intake hose joint fitting.
- Remove the old suction filter and intake port packing.
- Remove all of the old liquid gasket from the hydraulic tank.
- Remove all of the old liquid gasket and the intake port packing from the intake hose joint fitting.
- Wash and clean the intake hose joint fitting.
- Apply liquid gasket to the new intake port packing and then install it to the intake hose joint fitting.
- Install the new suction filter to the intake hose joint fitting.
- Install the intake hose joint fitting to the hydraulic tank.

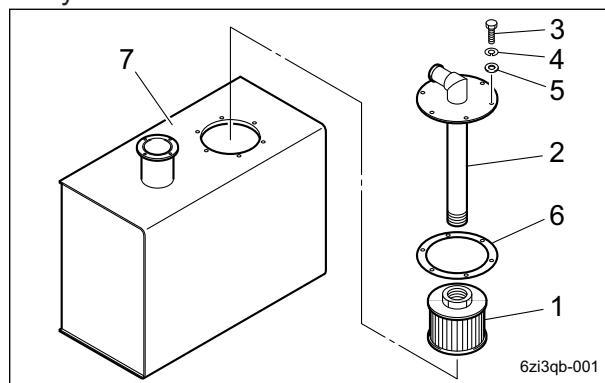

Change of Hydraulic Oil Suction Filter\_001

1	Suction filter
2	Intake hose joint fitting
3	Bolt
4	Spring washer
5	Washer
6	Intake port packing
7	Hydraulic tank

- Supply hydraulic oil until it reaches the specified level.  
"Hydraulic Oil Supply" (Page 4-5)
- Start the engine and stop it after hydraulic oil warmed.



13. Check underneath the machine for hydraulic oil leakage.
14. Install the left tank cover.

### Change of Air Cleaner

A contaminated air cleaner element may cause malfunction of the engine.

To maximize the life of the engine, replace the air cleaner element at the appropriate times.

1. The timing for replacing the air cleaner element is described below.
  - [1] Replace the air cleaner element in accordance with the Maintenance Schedule.
  - [2] If it is significantly contaminated, replace it, even if the hours of operation do not exceed the specified time.
2. Replace the air cleaner element by following the same steps as for cleaning the air cleaner. "Cleaning of Air Cleaner" (Page 4-6)

### Change of Engine Oil

#### ⚠ Caution

Be careful with hot oil, which could cause burns if it contacts your skin.

#### Important

When you change the engine oil, be sure to drain it into a bowl and discard it in accordance with local laws and regulations.

#### Important

Be sure to use engine oil that is classified as JASO DH-2 or API Service Grade CJ-4, with SAE viscosity that is appropriate for the operating environment (ambient temperature).

#### Important

Securely screw in the oil level gauge and oil filler cap.

Change the engine oil more frequently if the engine oil is contaminated, or if you use the machine in dusty areas or operate the engine at high loads or in high temperatures.

1. Move the machine onto a level surface, stop the engine, remove the drain plug while the engine oil is warm, and then drain the oil into a bowl.
2. Replace the drain plug in the engine.

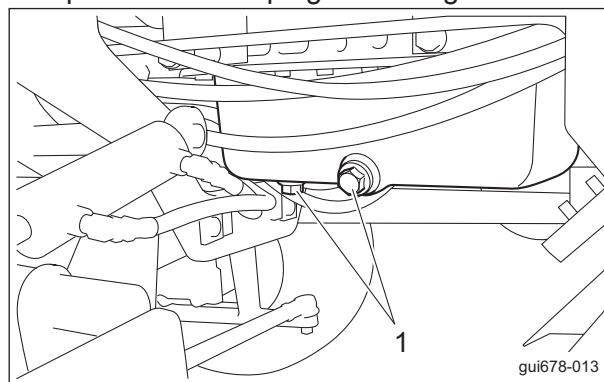

Change of Engine Oil\_001

1 Drain plug

3. Through the oil filling port, supply new engine oil until the oil reaches a level in between the upper and lower limit lines on the oil level gauge. Engine oil quantity is approximately 9.7 dm<sup>3</sup> (9.7 L).
4. Replace the oil filler cap.

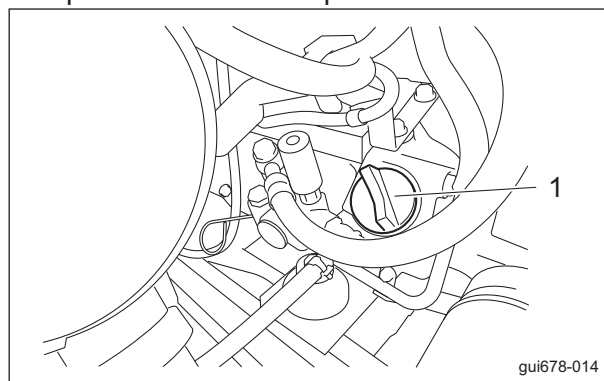

Change of Engine Oil\_002

1 Oil filler cap

5. It will take a while for the supplied engine oil to descend into the oil pan. Check the oil level again 10 to 20 minutes after supplying the oil.
6. Check underneath the machine for oil leakage.

# Maintenance

## Replacement of Engine Oil Filter

### ⚠ Caution

Be careful with hot oil, which could cause burns if it contacts your skin.

### Important

When replacing the engine oil filter, be sure to drain the engine oil into a container and discard it in accordance with local laws and regulations.

### Important

Be sure to use engine oil that is classified as JASO DH-2 or API Service Grade CJ-4, with SAE Viscosity that is appropriate for the operating environment (ambient temperature).

### Important

Securely tighten the oil level gauge and oil filler cap.

1. With the filter wrench, remove the old filter cartridge.

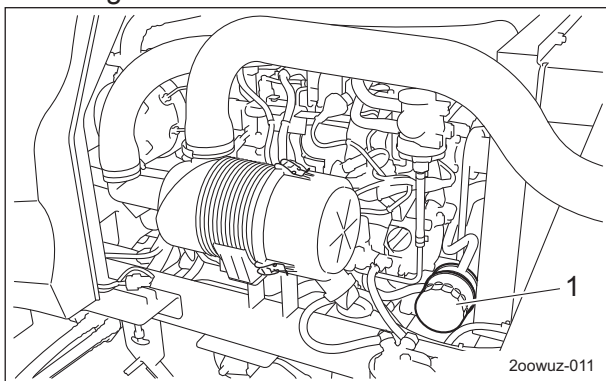

Replacement of Engine Oil Filter\_001

1	Filter cartridge
---	------------------

2. Lightly coat the packing of the new filter cartridge with engine oil.
3. Hand-tighten the filter cartridge until the packing contacts the sealing surface, and then firmly hand-tighten (without using a filter wrench).
4. Supply engine oil until it reaches the specified level.  
"Supply of Engine Oil" (Page 4-10)
5. Start the engine, and then stop it after 10 to 20 minutes.

6. Make sure that there is no oil leakage at the sealing surface of the filter cartridge.
7. Check the engine oil level.  
If it is low, supply engine oil until it reaches the specified level.

## Replacement of Fuel Filter

### Important

During installation, prevent contamination with dirt or dust.

If the fuel is contaminated with dirt, dust, etc., the fuel injection pump and injection nozzle will become worn.

Since the fuel filter is a cartridge, it cannot be disassembled or cleaned.

If dust or dirt accumulates in the fuel filter, the fuel flow will become insufficient.

Replace the fuel filter at the appropriate times.

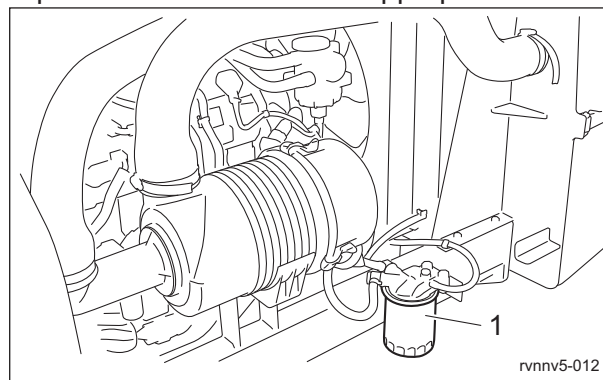

Replacement of Fuel Filter\_001

1	Fuel filter
---	-------------

1. Follow the steps below to replace the fuel filter.
  - [1] Using a filter wrench, remove the fuel filter cartridge.
  - [2] Lightly coat the packing of the new cartridge with fuel, and then firmly hand-tighten the cartridge, without using the filter wrench.

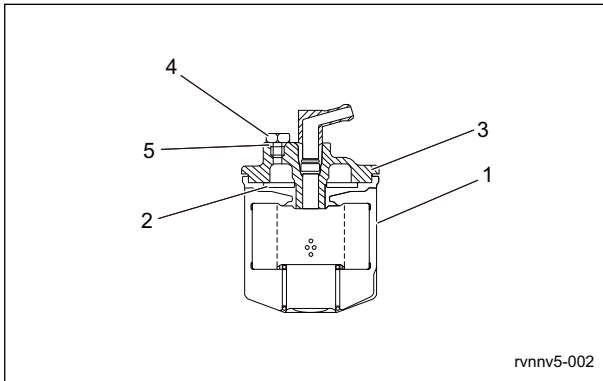

rvnnv5-002

Replacement of Fuel Filter\_002

1	Cartridge
2	Packing
3	Cover
4	Air-bleeding plug
5	O-ring

2. Remove air after replacement.

## Change of Fuse

### Important

When performing maintenance on the electrical system, be sure to remove the negative battery wire.

### Important

If a fuse blows, a short may have occurred within the electrical circuit. Check for the cause, such as faulty terminal connections, damaged wiring or terminals, or incorrect wiring.

### Important

For fuse replacement, clean the fuse mounting area with use of compressed air before mounting the fuse.

## Fuse Box

The fuse box includes spare fuses and tools.

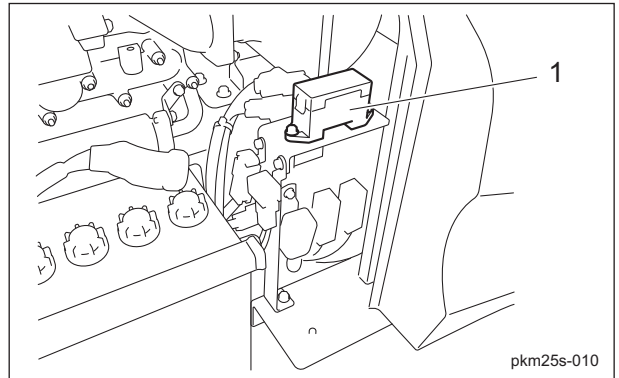

pkm25s-010

Fuse Box\_001

1	Fuse box
---	----------

The machine uses a mini fuse for automobiles.

Replace an old fuse with a new fuse of the specified capacity.

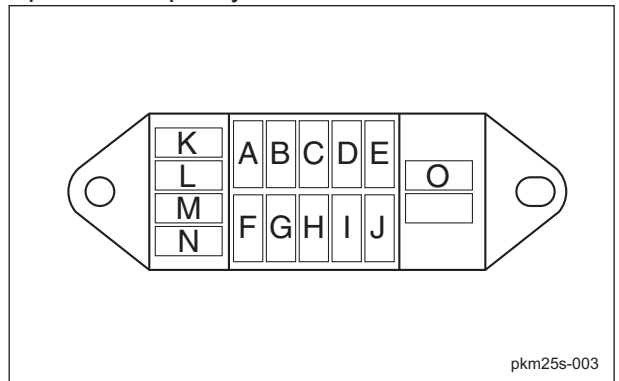

pkm25s-003

Fuse Box\_002

# Maintenance

A	5 A	ECU_KeySwitch_ON
B	5 A	Alternator
C	5 A	Display
D	15 A	Relay box 1(differential lock switch, assist switch)
E	15 A	Relay box 2 (2WD/4WD selector switch, #4/#5 proximity switches)
F	-	-
G	5 A	ECU_KeySwitch_Start
H	5 A	ECU_Parked Regeneration Switch/Auto Regeneration Inhibit Switch
I	5 A	Operating oil buzzer
J	5 A	Water temperature buzzer
K	5 A	Spare
L	5 A	
M	15 A	
N	15 A	
O	Fuse removal tool	

## Fusible Link

Fuse capacities of the fusible links are 30 A and 50 A.

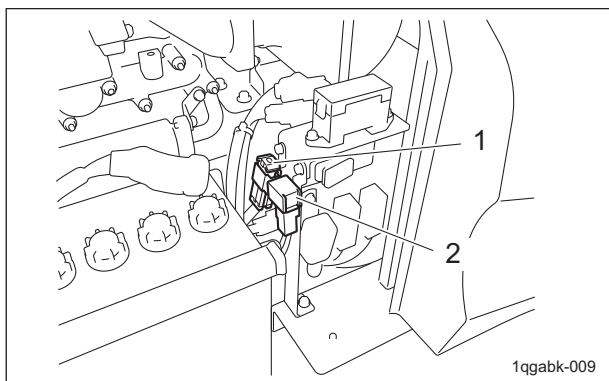

Fusible Link\_001

1	Fusible link (50 A)
2	Fusible link (30 A)

**EU Declaration of Conformity**

## Product Identification

Product : Lawnmower  
Brand-Name : BARONESS  
Type : GM2810  
Version(s) : A  
Starting Serial No. : **11060**  
Measured Sound Power Level : LWA 104,30 dB  
Guaranteed Sound Power Level : LWA 105 dB  
Manufacturer Name : Kyoeshisa Co., Ltd.  
Address : 1-26 Miyuki-cho, Toyokawa, Aichi-pref., Japan

## Conforms to the following Directives

2006/42/EC Machinery (MD)  
2014/30/EU Electromagnetic compatibility (EMC)  
2000/14/EC Noise emissions from outdoor equipment

## We have been designed and manufactured under the following specifications

ISO 12100 : 2010 (2006/42/EC)  
ISO 5395-1 : 2013 (2006/42/EC)  
ISO 5395-3 : 2013 (2006/42/EC)  
ISO 14982 : 1998 (2014/30/EU)

## Keeper of Technical Documentation

Name : Kyoeshisa Co., Ltd.  
Address : 1-26 Miyuki-cho, Toyokawa, Aichi-pref., Japan

## Compiler of the technical file (2006/42/EC)

Name : Friedrich E. Barthels Nachf. Glockzin KG (GmbH & Co.)  
Address : Gerhard-Falk-Str. 1 21035 Hamburg Germany

## Conformity assessment procedures

Internal production control : Module A (2006/42/EC)  
EC-type examination : Module B (2014/30/EU)  
Internal control of production with assessment of technical documentation and periodical checking (2000/14/EC)

## Involved Notified Body (2000/14/EC)

Name : SNCH  
Address : 11, Route de Sandweiler 5230 Sandweiler Luxembourg  
Certificate / Technical Documentation No. : SNCH\*2000/14\*2005/88\*2910\*02/TCGM2810-02

Place : Japan

Date : 21 December 2020 (21 / 12 / 2020)

Signature :

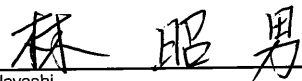
  
Name : Akio Hayashi  
Position : Quality Dept. Director

(fr)

**Déclaration de conformité UE**

## Identification du produit

Produit : Tondeuse à gazon  
Fabriquant : BARONESS  
Type : GM2810  
Version(s) : A  
Numéro de série de début : **11060**  
Niveau de puissance acoustique mesuré : LwA 104,30 dB  
Niveau de puissance acoustique garanti : LwA 105 dB  
Fabricant Nom : Kyoeshisa Co., Ltd.  
Adresse : 1-26, Miyuki-cho, Toyokawa, préfecture d'Aichi, Japon

## Conforme aux directives suivantes :

2006/42/CE Machine (MD)  
2014/30/UE Compatibilité électromagnétique (CEM)  
2000/14/CE Émissions sonores de l'équipement de plein air

## Conception et fabrication en respect des spécifications suivantes :

ISO 12100 : 2010 (2006/42/CE)  
ISO 5395-1 : 2013 (2006/42/CE)  
ISO 5395-3 : 2013 (2006/42/CE)  
ISO 14982 : 1998 (2014/30/UE)

## Fiche technique

Marque : Kyoeshisa Co., Ltd.  
Adresse de la marque : 1-26, Miyuki-cho, Toyokawa, préfecture d'Aichi, Japon

## Compilateur de la fiche technique (2006/42/CE)

Nom : Friedrich E. Barthels Nachf. Glockzin KG (GmbH & Co.)  
Adresse : Gerhard-Falk-Str. 1 21035 Hambourg Allemagne

## Procédures d'évaluation de la conformité

Contrôle de production interne : module A (2006/42/CE)  
Examen de type CE : module B (2014/30/UE)  
Contrôle interne de la production avec évaluation de la fiche technique et vérification périodique (2000/14/CE)

## Organisme notifié impliqué (2000/14/CE)

Nom : SNCH  
Adresse : 11, Route de Sandweiler 5230 Sandweiler, Luxembourg  
N° de certificat/Documentation technique : SNCH\*2000/14\*2005/88\*2910\*02/TCGM2810-02

## Declaración de conformidad de la UE

### Identificación del producto

Producto: Cortacésped  
 Marca: BARONESS  
 Tipo: GM2810  
 Versión: A  
 N.º de serie inicial: **11060**  
 Nivel de potencia sonora medido: LWA 104,30 dB  
 Nivel de potencia sonora garantizado: LWA 105 dB  
 Fabricante Nombre: Kyoeshisa Co., Ltd.  
 Dirección: 1-26 Miyuki-cho, Toyokawa, Aichi-pref., Japón

### Cumple las siguientes Directivas

2006/42/CE Maquinaria (MD)  
 2014/30/UE Compatibilidad electromagnética (EMC)  
 2000/14/CE Emisiones sonoras de máquinas de uso al aire libre

### Se ha diseñado y fabricado utilizando las siguientes especificaciones

ISO 12100 : 2010 (2006/42/CE)  
 ISO 5395-1 : 2013 (2006/42/CE)  
 ISO 5395-3 : 2013 (2006/42/CE)  
 ISO 14982 : 1998 (2014/30/UE)

### Documentación técnica

Nombre del responsable: Kyoeshisa Co., Ltd.  
 Dirección del responsable: 1-26 Miyuki-cho, Toyokawa, Aichi-pref., Japón

### Compilador del archivo técnico (2006/42/CE)

Nombre: Friedrich E. Barthels Nachf. Glockzin KG (GmbH & Co.)  
 Dirección: Gerhard-Falk-Str. 1 21035 Hamburgo Alemania

### Procedimientos de evaluación de conformidad

Control de fabricación interno: Módulo A (2006/42/CE)  
 Examen de tipo CE: Módulo B (2014/30/UE)  
 Control interno de fabricación con evaluación de documentación técnica y comprobaciones periódicas (2000/14/CE)

### Organismo notificado implicado (2000/14/CE)

Nombre: SNCH  
 Dirección: 11, Route de Sandweiler 5230 Sandweiler Luxemburgo  
 Certificado/Documentación técnica n.º: SNCH\*2000/14\*2005/88\*2910\*02/TCGM2810-02

## EU-Konformitätserklärung

### Produktbeschreibung

Produkt: Rasenmäher  
 Marke: BARONESS  
 Modell: GM2810  
 Version(en): A  
 Startseriennummer: **11060**  
 Gemessener Schalleistungspegel: LWA 104,30 dB  
 Garantierter Schalleistungspegel: LWA 105 dB  
 Hersteller Name: Kyoeshisa Co., Ltd.  
 Adresse: 1-26 Miyuki-cho, Toyokawa, Aichi-pref., Japan

### Entspricht den folgenden Richtlinien

2006/42/EG Maschinenrichtlinie  
 2014/30/EU Elektromagnetische Verträglichkeit (EMV)  
 2000/14/EG Geräuschemission von im Freien betriebenen Geräten

### Unter Anwendung der folgenden Bestimmungen entwickelt und hergestellt

ISO 12100 : 2010 (2006/42/EG)  
 ISO 5395-1 : 2013 (2006/42/EG)  
 ISO 5395-3 : 2013 (2006/42/EG)  
 ISO 14982 : 1998 (2014/30/EU)

### Technische Dokumentation

Name des Halters: Kyoeshisa Co., Ltd.  
 Adresse des Halters: 1-26 Miyuki-cho, Toyokawa, Aichi-pref., Japan

### Technische Unterlagen erstellt von (2006/42/EG)

Name: Friedrich E. Barthels Nachf. Glockzin KG (GmbH & Co.)  
 Adresse: Gerhard-Falk-Str. 1 21035 Hamburg Deutschland

### Konformitätsbewertungsverfahren

Interne Produktionskontrolle : Modul A (2006/42/EG)  
 EG-Baumusterprüfung : Modul B (2014/30/EU)  
 Interne Produktionskontrolle mit Bewertung der technischen Unterlagen und regelmäßiger Überprüfung (2000/14/EG)

### Beteiligte benannte Stelle (2000/14/EG)

Name: SNCH  
 Adresse: 11, Route de Sandweiler 5230 Sandweiler Luxemburgo  
 Bescheinigung/Technische Dokumentation Nr.: SNCH\*2000/14\*2005/88\*2910\*02/TCGM2810-02

## EU-försäkran om överensstämmelse

### Produktidentifikation

Produkt : Gräsklippare  
 Märke: BARONESS  
 Typ: GM2810  
 Version(er): A  
 Serienummer startar på: **11060**  
 Uppmätt ljudeffektnivå: LWA 104.30 dB  
 Garanterad ljudeffektnivå: LWA 105 dB  
 Tillverkare Namn: Kyoeshia Co., Ltd.  
 Address: 1-26 Miyuki-cho, Toyokawa, Aichi-pref., Japan

### Uppfyller följande direktiv

2006/42/EG Maskindirektivet  
 2014/30/EU Elektromagnetisk kompatibilitet (EMC)  
 2000/14/EG Bulleremission från utomhusutrustning

### Följande kravspecifikationer har följts vid konstruktion och tillverkning

ISO 12100 : 2010 (2006/42/EG)  
 ISO 5395-1 : 2013 (2006/42/EG)  
 ISO 5395-3 : 2013 (2006/42/EG)  
 ISO 14982 : 1998 (2014/30/EU)

### Teknisk dokumentation

Innehavarens namn: Kyoeshia Co., Ltd.  
 Innehavarens adress: 1-26 Miyuki-cho, Toyokawa, Aichi-pref., Japan

### Den tekniska filen(2006/42/EG) har tagits fram av

Namn: Friedrich E. Barthels Nachf. Glockzin KG (GmbH & Co.)  
 Address: Gerhard-Falk-Str. 1 21035 Hamburg Tyskland

### Förfarande för bedömning av överensstämmelse

Intern produktionskontroll: Modul A (2006/42/EG)  
 EG-typprovning: Modul B (2014/30/EU)  
 Intern kontroll av produktion med fastställande av teknisk dokumentation och periodiska kontroller (2000/14/EG)

### Anmält organ (2000/14/EG)

Namn: SNCH  
 Address: 11, Route de Sandweiler 5230 Sandweiler Luxembourg  
 Certifikat/Teknisk dokumentation nummer: SNCH\*2000/14\*2005/88\*2910\*02/TCGM2810-02

## EU-overensstemmelseserklæring

### Produktidentificering

Produkt : Plæneklipper  
 Mærkenavn: BARONESS  
 Type: GM2810  
 Version(er): A  
 Startende serienr.: **11060**  
 Målt lydeffektniveau: LWA 104.30 dB  
 Garanteret lydeffektniveau: LWA 105 dB  
 Producent Navn: Kyoeshia Co., Ltd.  
 Adresse: 1-26 Miyuki-cho, Toyokawa, Aichi-præf., Japan

### Er i overensstemmelse med følgende direktiver

2006/42/EF Maskineri (MD)  
 2014/30/EU Elektromagnetisk kompatibilitet (EMC)  
 2000/14/EF Støjmissioner fra udendørs udstyr

### Vi har designet og produceret under følgende specifikationer

ISO 12100 : 2010 (2006/42/EF)  
 ISO 5395-1 : 2013 (2006/42/EF)  
 ISO 5395-3 : 2013 (2006/42/EF)  
 ISO 14982 : 1998 (2014/30/EU)

### Indehaver af teknisk dokumentation

Navn: Kyoeshia Co., Ltd.  
 Adresse: 1-26 Miyuki-cho, Toyokawa, Aichi-præf., Japan

### Kompilator af den tekniske fil (2006/42/EF)

Navn: Friedrich E. Barthels Nachf. Glockzin KG (GmbH & Co.)  
 Adresse: Gerhard-Falk-Str. 1 21035 Hamborg Tyskland

### Procedurer for overensstemmelsesvurdering

Intern produktionskontrol : Modul A (2006/42/EF)  
 EF-typeafprøvning : Modul B (2014/30/EU)  
 Intern fabrikationskontrol med vurdering af teknisk dokumentation og periodisk kontrol (2000/14/EF)

### Berørt bemyndiget organ (2000/14/EF)

Navn: SNCH  
 Adresse: 11, Route de Sandweiler 5230 Sandweiler Luxembourg  
 Certifikat: SNCH\*2000/14\*2005/88\*2910\*02/TCGM2810-02

**BARONESS**<sup>®</sup>  
Quality on Demand

 **KYOEISHA CO., LTD.**  
Head Office 1-26, Miyuki-cho, Toyokawa-city, Tel :+81-533-84-1390  
Aichi-pref, 442-8530 JAPAN Fax:+81-533-84-1220