

# ***LM551B***

5-Unit Reel Mower

## Owner's Operating Manual

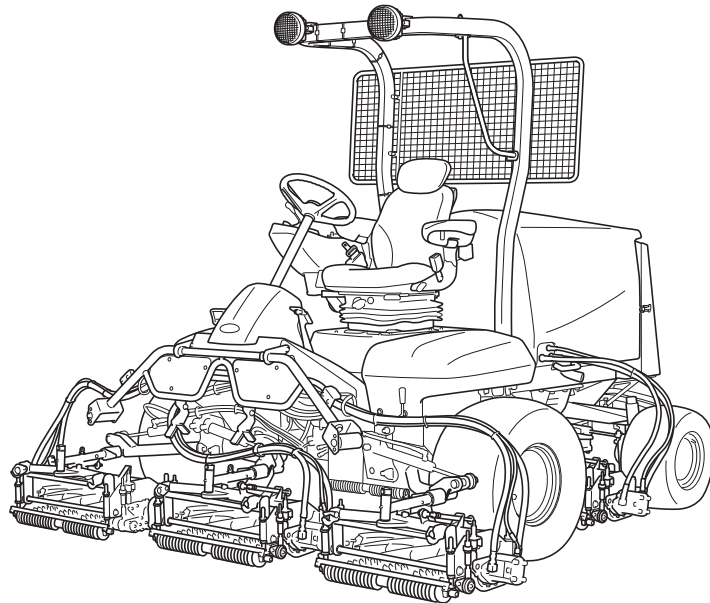

Serial No. LM551B : 30038-

"Required reading"  
Read this manual before using the machine.

---

**BARONESS**<sup>®</sup>  
Quality on Demand

Original Instructions Ver.1.1

# Regulations

## California Proposition 65

(For California, USA)

**⚠ WARNING:**

Operating, servicing and maintaining a passenger vehicle or off-road vehicle can expose you to chemicals including engine exhaust, carbon monoxide, phthalates, and lead, which are known to the State of California to cause cancer and birth defects or other reproductive harm. To minimize exposure, avoid breathing exhaust, do not idle the engine except as necessary, service your vehicle in a well-ventilated area and wear gloves or wash your hands frequently when servicing your vehicle. For more information go to [www.P65Warnings.ca.gov/passenger-vehicle](http://www.P65Warnings.ca.gov/passenger-vehicle).

318yi8-005

California Proposition 65\_001

## California Spark Arrester

(For California, USA)

**⚠ Warning**

Operation of this equipment may create sparks that can start fires around dry vegetation.  
A spark arrester may be required.  
The operator should contact local fire agencies for laws or regulations relating to fire prevention requirements.

The DPF installed on the engine of this machine meets requirements of California Public Resource Code Section 4443.

## EU Emission Control (Stage V)

(For Europe)

**Important**

No deliberate tampering with or misuse of the engine emissions control system should take place.  
Make repairs immediately if the fault codes of PCD (Particulate Control Diagnostic) and NCD (NOx Control Diagnostic) appear.  
Tampering with and use without effect of the engine emissions control system are regulatory infringements and they are penalized.

Thank you for purchasing the Baroness product. This manual describes the proper handling, adjustment, and inspection of your product. We hope you will use the product safely, and take advantage of its best performance. For details on the handling, adjustment and inspection of the attachments, refer to the Owner's Operating Manual for the attachments.

## Keeping The Owner's Operating Manual

Keep this Manual in the bag located in the rear of the seat.

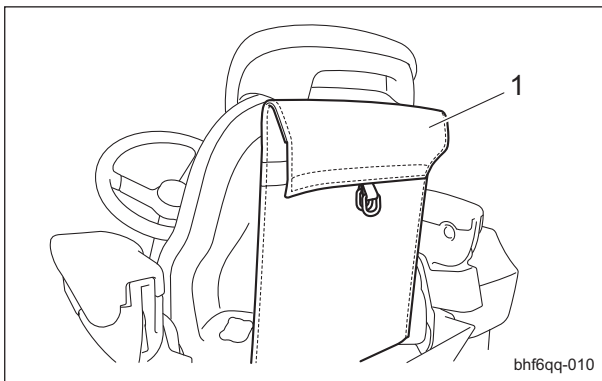

Keeping The Owner's Operating Manual\_001

1	Bag
---	-----

# Introduction

---

Read this manual carefully to ensure that you thoroughly understand how to properly operate and maintain the product, and to avoid causing injury to yourself or others.

The operator is responsible for operating the product properly and safely.

Maintenance service for this machine should be performed by a mechanic with expertise.

If you have any questions concerning maintenance or genuine parts, please contact a Baroness dealer or Kyoisha.

When making inquiries about the product, please specify the product's model designation and serial number.

When loaning or transferring the product, please also provide this manual together with the product.

Kyoisha Co., Ltd.

## Warning Symbols

This manual uses the following warning symbols for handling precautions that are important for your safety.



696cq5-001

Warning symbol

This symbol indicates the articles regarding “Danger,” “Warning,” or “Caution.”

Those articles describe important safety precautions and so read them carefully to understand completely before operating the machine.

Failure to adequately follow these safety precautions may cause an accident.

### **Danger**

This symbol indicates that serious injury or death will occur if the warning is ignored.

### **Warning**

This symbol indicates that serious injury or death may occur if the warning is ignored.

### **Caution**

This symbol indicates that injury or damage to property may occur if the warning is ignored.

### **Important**

This symbol indicates precautions on the mechanism of the machine.

## Precautionary Statement

 Caution

The information described in this manual is subject to change for improvement without prior notice.

When replacing parts, be sure to use genuine Baroness parts or parts designated by Kyoeshia.

Note that the Baroness product warranty may not apply to defects caused by the use of parts from other companies.

Prior to use, carefully read the following manuals to thoroughly understand the contents for safe and correct operation.

- Baroness Owner's Operating Manual
- The Engine's Owner's Manual
- The Battery's Owner's Manual

## Purpose

This product is intended for cutting turf grass at golf courses.

Do not use this product in any way other than its intended purpose, and do not modify this product.

Operating this product for other purposes and modifying it may be very dangerous and may cause damage to the product.

In addition, this product is not authorized for operation as a special motor vehicle. Do not operate it on public roads.

LM551B

# Introduction

---

<b>Safety</b> .....	<b>Page 1-1</b>
Safe Operating Practices .....	Page 1-2
<b>Disposal</b> .....	<b>Page 2-1</b>
Recycle and Waste Disposal .....	Page 2-2
<b>Product Overview</b> .....	<b>Page 3-1</b>
Specifications .....	Page 3-2
Names of Each Section .....	Page 3-5
Regulation Decals .....	Page 3-5
Safety Signs and Instruction Signs .....	Page 3-9
<b>Handling Instructions</b> .....	<b>Page 4-1</b>
Inspections .....	Page 4-3
Daily Check List .....	Page 4-3
Tightening Torques .....	Page 4-16
Adjustment before Work .....	Page 4-20
Procedure to Start/Stop Engine .....	Page 4-23
Operation Method .....	Page 4-25
Instruments .....	Page 4-41
Move .....	Page 4-104
Cutting Work .....	Page 4-105
Transporting .....	Page 4-106
Storage .....	Page 4-106
<b>Maintenance</b> .....	<b>Page 5-1</b>
Maintenance Precautions .....	Page 5-2
Maintenance Schedule .....	Page 5-2
DPF .....	Page 5-8
Jacking Up The Machine .....	Page 5-22
Greasing .....	Page 5-24
Lubrication .....	Page 5-28
Maintenance Work .....	Page 5-30

LM551B

# Contents

---



**Safe Operating Practices ..... Page 1-2**

Training ..... Page 1-2

Preparation ..... Page 1-2

Operation ..... Page 1-3

Maintenance ..... Page 1-4

Storage ..... Page 1-5



# Safety

Failure to adequately follow these safety precautions may cause an accident resulting in injury or death.

## Danger

This product is designed to ensure safe operation and has been tested and inspected thoroughly before shipment from the factory. The product is equipped with safety devices to prevent accidents.

However, whether the product demonstrates its original performance level depends on the manner in which it is operated and handled, as well as the manner in which it is managed on a daily basis.

Inappropriate use or management of the product may result in injury or death.

Observe the following safety instructions to ensure safe operation.

## Safe Operating Practices

### Training

1. Read this manual and other training material carefully.

Be familiar with the controls, safety signs, and the proper use of the equipment.

2. If the operator or mechanic can not read the language used in this manual, it is the owner's responsibility to explain this material to them.

3. All operators and mechanics should seek and obtain professional and practical instruction.

The owner is responsible for training the users.

Such instruction should emphasize:

- [1] The need for care and concentration when working with ride-on machines.

- [2] Control of a ride-on machine sliding on a slope will not be regained by the application of the brake.

The main reasons for loss of control are

- Insufficient wheel grip
- Being driven too fast
- Inadequate braking
- The type of machine is unsuitable for its task
- Lack of awareness of the effect of ground conditions, especially slopes
- Incorrect hitching and load distribution

4. Never allow children or people unfamiliar with these instructions to use or service the machine.

Local regulations may restrict the age of the operator.

5. The owner/user can prevent and is responsible for accidents or injuries occurring to themselves, other people, or property.
6. Keep in mind that the owner, operator, and mechanic are responsible for accidents or hazards occurring to other people or their property.
7. The ROPS is an integral and effective safety device.  
Do not remove or alter the ROPS.
8. Replace a damaged ROPS.  
Do not repair or alter.
9. You can find additional safety information where needed throughout this manual.
10. Determine the left and right sides of the machine from the normal operating position.

### Preparation

1. Evaluate the terrain to determine what accessories and attachments are needed to properly and safely perform the job.  
Only use accessories and attachments approved by the manufacturer.
2. While operating, always wear substantial footwear, long trousers, hard hat, safety glasses, mask, and ear protection.  
Long hair, loose clothing, or jewelry may get tangled in moving parts.  
Do not operate the equipment when barefoot or wearing open sandals.
3. Inspect the area where the equipment is to be used and remove all objects such as rocks, toys and wire which can be thrown by the machine.
4. Keep children out of the operating area and under the watchful care of a responsible adult other than the operator.
5. Exercise care in the handling of fuel.

## Warning

Fuel is highly flammable.

Take the following precautions:

- [1] Store fuel in containers specifically designed for this purpose.

- [2] Add fuel before starting the engine.  
Never remove the cap of the fuel tank or add fuel while the engine is running or when the engine is hot.
- [3] Refuel outdoors only and do not smoke while refueling.
- [4] If fuel is spilled, do not attempt to start the engine but move the machine away from the area of spillage and avoid creating any source of ignition until petrol vapours have dissipated;
- [5] Replace all fuel tanks and container caps securely.
6. Check that operator's presence controls, safety switches and shields are attached and functioning properly.  
Do not operate unless they are functioning properly.
7. If the brake operation is faulty, be sure to adjust or repair them before operating the machine.
8. Replace faulty mufflers.
9. On multi-cylinder/multi-reel machines, take care as rotating one cylinder/reel can cause other cylinders/reels to rotate.
8. Never operate while people, especially children, or pets are nearby.
9. Only operate in good light, keeping away from holes and hidden hazards.
10. Do not operate the machine when there is the risk of lightning.
11. Do not stop or start suddenly.
12. Look behind and down before backing up to be sure of a clear path.
13. Slow down and use caution when making turns and crossing roads and sidewalks.
14. Use care when approaching blind corners, shrubs, trees, or other objects that may obscure vision.
15. Do not take your eyes off the road ahead.  
Do not operate the machine with no hands.
16. Remember there is no such thing as a safe slope.  
Travel on grass slopes requires particular care.  
To guard against overturning, follow these instructions.

## Operation

1. Do not operate the machine under the influence of alcohol or drugs.
2. Do not operate the engine in a confined space where dangerous carbon monoxide fumes can collect.
3. Be sure all drives and shift are in neutral and parking brake is engaged before starting engine.  
Only start engine from the operator's position.  
Use seat belts if provided.
4. Do not change the engine governor settings or overspeed the engine.  
Operating the engine at excessive speed may increase the hazard of personal injury.
5. Never operate the machine with damaged guards, shields, or without safety protective devices in place.  
Be sure all interlocks are attached, adjusted properly, and functioning properly.
6. Keep hands and feet away from the rotating parts.
7. Do not carry passengers.
- [1] Do not stop or start suddenly when going up or downhill.
- [2] Engage clutch slowly, always keep machine in gear, especially when traveling downhill.
- [3] Machine speeds should be kept low on slopes and during turns.
- [4] Stay alert for humps and hollows and other hidden hazards.
17. Never use the machine on a slope with an angle of gradient that is greater than that specified or in a place where there is a danger of the machine slipping.
18. Use extra care while operating machine with a grass catcher or other attachments.  
They can affect the stability of the machine.
19. Disengage drive to the cutting unit(s), when other than operating.
20. Do the following before leaving the operator's position.
  - [1] Stop on level ground.
  - [2] Disengage the all drives.
  - [3] Set the parking brake.
  - [4] Stop the engine.
  - [5] Remove the ignition key.
21. Stop the engine in the following conditions.
  - [1] Before refuelling.

# Safety

---

- [2] Before removing the grass catcher.
  - [3] Before making height or depth adjustment unless adjustment can be made from the operator's position.
  - [4] Before clearing blockages.
  - [5] Before checking, cleaning or working on the machine.
  - [6] After striking a foreign object or if an abnormal vibration occurs.  
Inspect the machine for damage and make repairs before restarting and operating the equipment.
22. Reduce the throttle setting during engine run-out.
  23. Do not direct discharge material toward anyone.  
Avoid discharging material against a wall or obstruction.  
Material may ricochet back toward the operator.
  24. Take care when loading or unloading the machine into a trailer or a truck.  
Load or unload the machine in a flat and safe place.  
Before loading or unloading, set the parking brake on the truck or trailer, stop the engine, and chock the wheels.  
When transporting the machine on a truck or a trailer, set the parking brake, stop the engine, and fasten the machine to the truck with a rope or other suitable restraining device that has sufficient strength.  
When using a running board, select one with sufficient strength, length, and width and that will not cause the machine to slip.
  25. Close the fuel valve before transporting the machine.

## Maintenance

1. Never allow untrained personnel to service machine.
2. Implement the following work before adjusting, cleaning or repairing.
  - [1] Stop the machine on level ground.
  - [2] Disengage drive to the cutting unit(s).
  - [3] Lower the cutting unit(s) and attachment(s) if installed.
  - [4] Set the parking brake.
  - [5] Stop the engine.
  - [6] Remove the ignition key.
  - [7] Wait for all movement to stop.
3. Allow the engine/muffler to cool before checking/maintenance.
4. To reduce the fire hazard, keep hot parts such as the engine and silencer/muffler, battery compartment and fuel storage area free of grass, leaves, or excessive grease. Clean up oil or fuel spillage.
5. Appropriately manage and correctly use the tools necessary for servicing or adjusting the machine.
6. Disconnect battery before making any repairs.  
Disconnect the negative terminal first and the positive last.  
Reconnect positive first and negative last.
7. Use jack stands to support components when required.
8. Keep hands and feet away from moving parts.  
If possible, do not make adjustments with the engine running.
9. Make sure that parts such as wires are not touching each other and that their covers have not come off.
10. Keep all parts in good working condition and all hardware tightened.  
Replace all worn or damaged decals.
11. Keep all nuts, bolts and screws tight to be sure the equipment is in safe working condition.
12. Carefully release pressure from components with stored energy.
13. Be sure to depressurize the hydraulic system before performing maintenance operations on it such as removing hydraulic equipment.
14. Check whether line connectors in the hydraulic system are properly tightened.  
Before applying hydraulic pressure, check the connections of the hydraulic pressure lines and the condition of the hoses.
15. When checking the hydraulic circuit for pinhole leaks or oil leakage from nozzles, do not use your hands.  
Use items such as paper or corrugated cardboard to find leakage points.

Be extremely careful with high-pressure oil as it may pierce your skin, resulting in an injury.

If fluid is injected into the skin it must be surgically removed within a few hours by a doctor familiar with this form of injury or gangrene may result.

16. Use care when checking the cylinders/reels and bed knives.  
Wear gloves and use caution when servicing them.
17. Be careful during adjustment of the machine to prevent entrapment of the fingers between moving blades and fixed parts of the machine.
18. On multi-cylinder/multi-reel machines, take care as rotating one cylinder/reel can cause other cylinders/reels to rotate.
19. Check the grass catcher frequently for wear or deterioration.
20. Charge batteries in an open well ventilated area, away from spark and flames.  
Unplug charger before connecting or disconnecting from battery.  
Wear protective clothing and use insulated tools.
21. If the fuel tank has to be drained, do this outdoors.

## Storage

1. When machine is to be parked, stored, or left unattended, lower the cutting unit(s) and attachment(s) if installed unless a positive mechanical lock is provided.
2. Allow the engine to cool before storing in any enclosure.
3. Only cover the machine with a sheet after hot parts have sufficiently cooled down.
4. Never store the equipment with fuel in the tank inside a building where fumes may reach an open flame or spark.
5. If the engine is provided with a shut-off valve, shut off valve while storing or transporting.
6. Do not store fuel near flames.
7. Swallowing engine coolant can cause injury or death; keep out of reach from children and pets.



**Recycle and Waste Disposal ..... Page 2-2**

About Recycle .....Page 2-2

About Waste Disposal ..... Page 2-2

Disposal

# Disposal

---

## Recycle and Waste Disposal

### About Recycle

Recycling battery etc. is recommended for environmental conservation and economical use of resources.

It may be required by local laws.

### About Waste Disposal

Make sure that waste generated when servicing or repairing the machine is disposed of in accordance with local regulations. (e.g. waste oil, antifreeze, rubber products, and wires etc.)



## **Specifications ..... Page 3-2**

Specifications .....	Page 3-2
Sound Pressure Level .....	Page 3-4
Sound Power Level .....	Page 3-4
Vibration Level .....	Page 3-4
Carbon Dioxide (CO <sub>2</sub> ) Emissions Measurement .....	Page 3-4

## **Names of Each Section ..... Page 3-5**

## **Regulation Decals .....Page 3-5**

Positions of Regulation Decals .....	Page 3-5
Description of Regulation Decals .....	Page 3-6

## **Safety Signs and Instruction Signs ..... Page 3-9**

About Safety Signs and Instruction Signs .....	Page 3-9
Positions of Safety Decals and Instruction Decals .....	Page 3-9
Description of Safety Decals and Instruction Decals .....	Page 3-11

# Product Overview

## Specifications

### Specifications

Model			LM551B				
Mower unit type			22 in		26 in		
Dimensions	Total width		116.14 in	295 cm	←	←	
	Total height	LH52	During operation	114.96 in	292 cm	-	-
			During transport	86.61 in	220 cm	-	-
		LH62 • 66	During operation	115.75 in	294 cm	126.77 in	322 cm
			During transport	86.61 in	220 cm	←	←
		LS62 • 66	During operation	114.96 in	292 cm	125.59 in	319 cm
			During transport	86.61 in	220 cm	←	←
	Total height		Roof	94.09 in	239 cm	←	←
		Handle	62.99 in	160 cm	←	←	
Weight	Machine (empty fuel tank)	LH52	with Groomer, CR brush, ROPS, Light and Ball proof net without Grass catcher	3326.78 lb	1519 kg	-	-
		LH62 • 66	with Groomer, CR brush, ROPS, Light and Ball proof net without Grass catcher	3527.40 lb	1610 kg	3668.43 lb	1664 kg
		LS62 • 66	with CR brush, ROPS, Light and Ball proof net without Grass catcher	3392.91 lb	1549 kg	3425.98 lb	1564 kg
	Grass catcher (for one machine)			50.71 lb	23.0 kg	55.11 lb	25.0 kg
Minimum turning radius	LH52	Front wheel (outer wheel) outside	120.47 in	306 cm	-	-	
		Outer side of unit	136.61 in	347 cm	-	-	
	LH62 • 66	Front wheel (outer wheel) outside	120.47 in	306 cm	←	←	
		Outer side of unit	136.61 in	347 cm	140.16 in	356 cm	
	LS62 • 66	Front wheel (outer wheel) outside	120.47 in	306 cm	120.47 in	306 cm	
		Outer side of unit	135.83 in	345 cm	139.37 in	354 cm	
Engine	Model		Kubota V1505-CR-TE5		←		
	Type		Vertical water-cooled 4-cycle diesel engine		←		

# Product Overview

Engine	Total displacement	91.41 cu.in.	1498 cm <sup>3</sup> (1.498 L)	←	←
	Maximum output	33.0 kW (44.9 PS)/3000 rpm		←	
Fuel tank capacity		Diesel 13.47 U.S.gals	Diesel 51.0 dm <sup>3</sup> (51.0 L)	←	←
Fuel consumption		192 g/PS · h (rated output)	262 g/kW · h (rated output)	←	←
Engine oil capacity		1.77 U.S.gals	6.7 dm <sup>3</sup> (6.7 L)	←	←
Coolant volume		3.17 U.S.gals	12.0 dm <sup>3</sup> (12.0 L)	←	←
Hydraulic tank capacity		8.01 U.S.gals	30.3 dm <sup>3</sup> (30.3 L)	←	←
Operating width (Mowing width)		100.00 in	254 cm	111 in	282 cm
Operating height (Mowing height)	LH52	0.197 - 0.787 in	5.0 - 20.0 mm	-	-
	LH62 · 66	0.315 - 1.772 in	8.0 - 45.0 mm	←	←
	LS62 · 66	0.394 - 1.811 in	10.0 - 46.0 mm	←	←
Drive	Traveling	HST (Full time 4WD)		←	
	Mowing	Hydraulic (Gear motor drive)		←	
Speed (HST)	Forward	9.94 mph	16.0 km/h	←	←
	Reverse	4.97 mph	8.0 km/h	←	←
Speed (Mechanical)		-		-	
Efficiency		6.02 acres/ hour (7.46 mph x mowing width x 0.8)	24,384 m <sup>2</sup> /h (12.0 km/h x mowing width x 0.8)	6.69 acres/ hour (7.46 mph x mowing width x 0.8)	27,072 m <sup>2</sup> /h (12.0 km/h x mowing width x 0.8)
Maximum inclination for operation		15 degrees		←	
Tire size	Front wheel	26.5 x 14.00-12		←	
	Rear wheel	20 x 12.00-10		←	
Tire pneumatic pressure	Front wheel	17.40 psi	120 kPa (1.2 kgf/cm <sup>2</sup> )	←	←
	Rear wheel	20.30 psi	140 kPa (1.4 kgf/cm <sup>2</sup> )	←	←
Battery		105D31L		←	
Engine plug		-		←	

The factory default maximum engine rpm is 3,000 rpm.

# Product Overview

---

## Sound Pressure Level

### Sound Pressure Level

This machine was confirmed to have a continuous A-weighted sound pressure level of 84 dB by measuring identical machines in accordance with the procedure specified in ISO5395-1:2013.

## Sound Power Level

### Sound Power Level

This machine was confirmed to have a sound power level of 103 dB by measuring identical machines in accordance with the procedure specified in ISO 5395-1:2013.

## Vibration Level

### Hand-Arm Vibration

This machine was confirmed not to exceed a vibration level of 2.5 m/s<sup>2</sup> to hands and arms by measuring identical machines in accordance with the procedure specified in ISO 5395-1:2013.

### Whole Body Vibration

This machine was confirmed not to exceed a vibration level of 0.5 m/s<sup>2</sup> to the whole body by measuring identical machines in accordance with the procedure specified in ISO 5395-1:2013.

## Carbon Dioxide (CO<sub>2</sub>) Emissions Measurement

For CO<sub>2</sub> emissions measurement on the engine of this machine, refer to the engine's owner's manual.

# Product Overview

## Names of Each Section

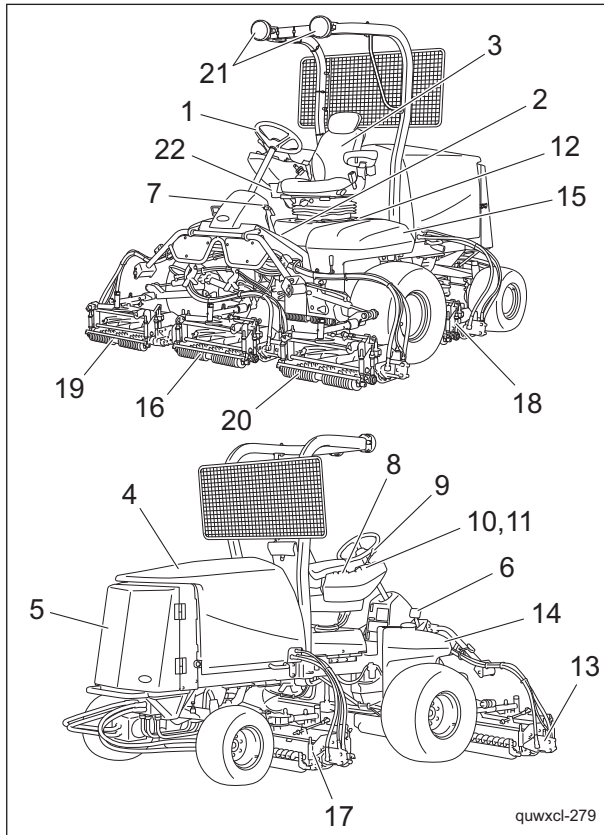

Names of Each Section\_001

1	Steering wheel
2	Tilt lever
3	Seat
4	Hood
5	Radiator cover
6	Traveling pedal
7	Brake pedal
8	Throttle knob
9	Mower unit up/down lever
10	Traveling/working selector switch
11	Reel rotation switch
12	Reel forward/reverse switch
13	Reel rotation/stop switching lever
14	Fuel tank
15	Hydraulic tank
16	Mower unit #1
17	Mower unit #2
18	Mower unit #3
19	Mower unit #4
20	Mower unit #5
21	Light
22	USB socket

## Regulation Decals

### Positions of Regulation Decals

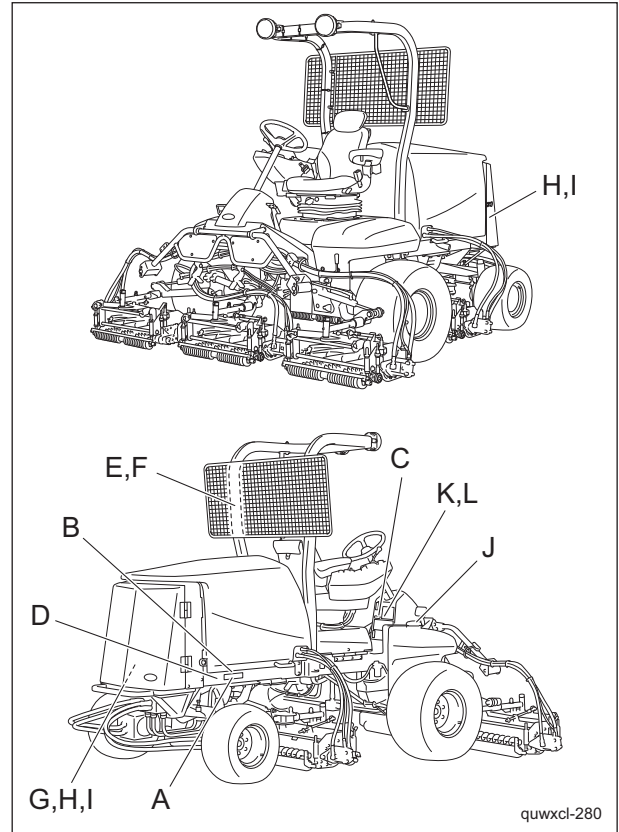

Positions of Regulation Decals\_001

A	Serial number plate
B	Specification decal
C	Noise emission decal
D	Year of manufacture decal
E	ROPS compliance decal
F	ROPS caution decal
G	Battery capacity decal
H	Recycle decal
I	Battery danger decal
J	Diesel instruction mark
K	California Proposition 65 decal (riding type)
L	Spark arrester warning decal

Product Overview

# Product Overview

## Description of Regulation Decals

### Serial Number Plate

The serial number plate indicates the model and serial number of the machine.

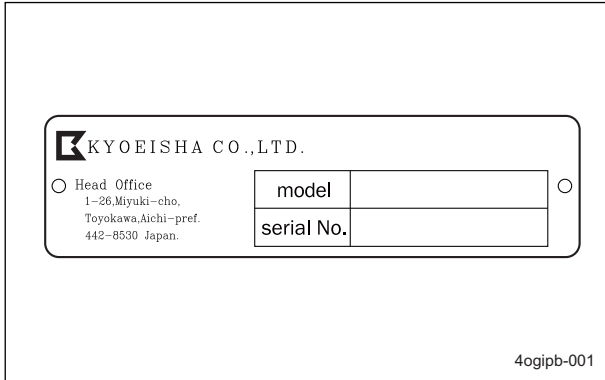

Serial Number Plate\_001

### Noise Emission Decal

(For Europe)

The noise emission decal indicates the sound power level determined by measuring identical machines in accordance with the procedure specified in the EC directives.

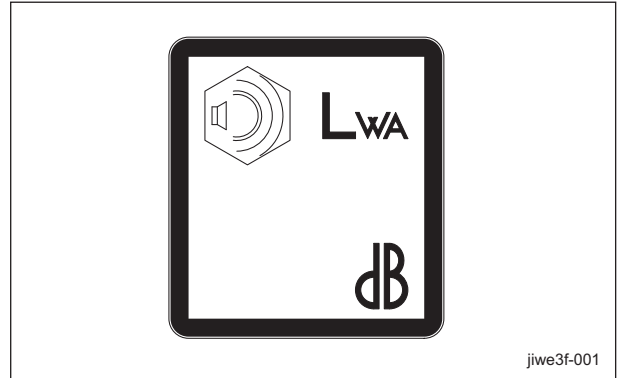

Noise Emission Decal\_001

### Specification Decal

(For Europe)

CE mark indicates that the machine sold in the EU nations complies with the EU requirements.

The Specification decal indicates the CE marking, model, and weight, etc.

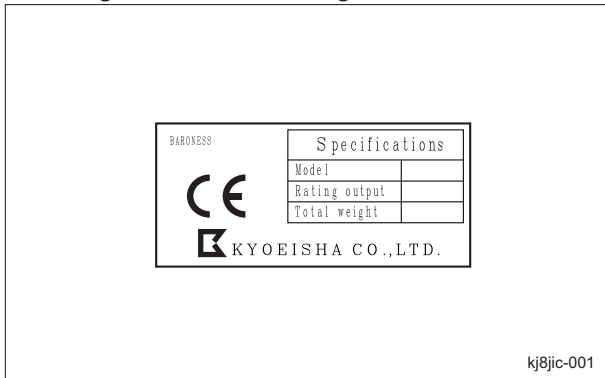

Specification Decal\_001

### Year of Manufacture Decal

(For Europe)

The year of manufacture decal indicates the year when this machine was manufactured.

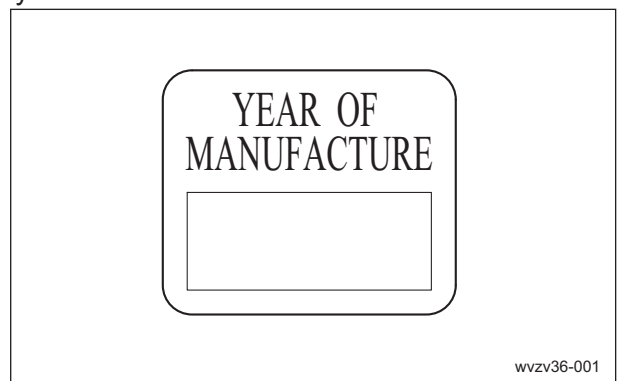

Year of Manufacture Decal\_001

### ROPS Compliance Decal

The ROPS compliance decal indicates the manufacturer, model, etc., in accordance with International Standard ISO 21299:2009.

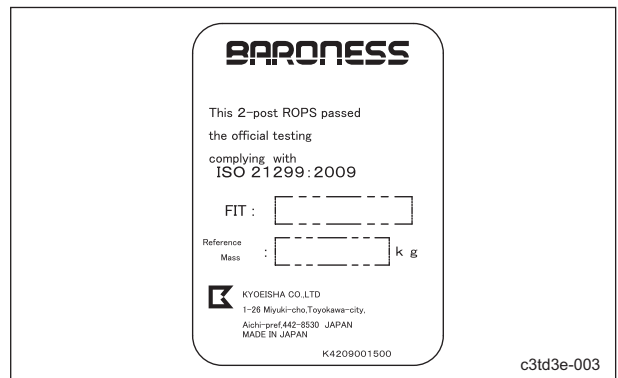

ROPS Compliance Decal\_001

## ROPS Caution Decal

ROPS caution decal describes the following caution messages.

- Replace damaged ROPS.
- Do not repair or revise.



ROPS Caution Decal\_001

## Recycle Decal

Recycle Decal illustrates Recycle Mark in accordance with local regulation.  
(For Europe)

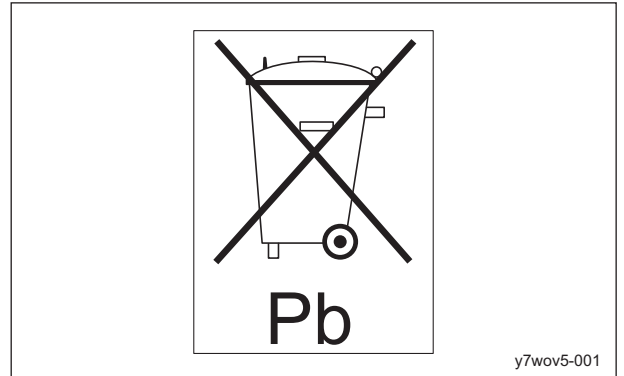

Recycle Decal\_001

## Battery Capacity Decal

(For Europe)

The battery capacity decal indicates the capacity by 20HR and CCA.

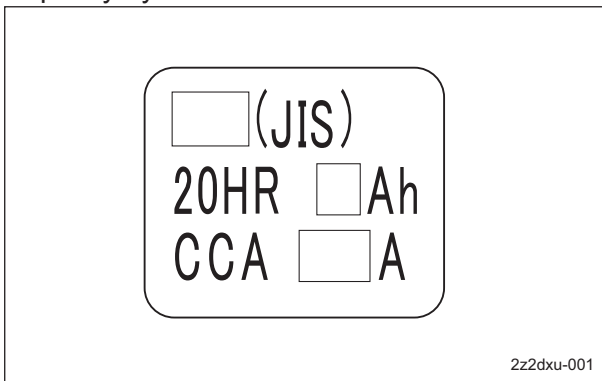

Battery Capacity Decal\_001

(For USA)



Recycle Decal\_002

# Product Overview

## Battery Danger Decal

(For USA)

Battery Danger Decal describes handling precautions for battery.

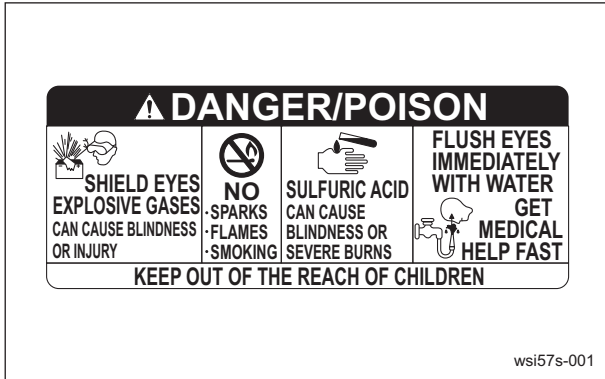

Battery Danger Decal\_001

## California Proposition 65 Decal (Riding Type)

(For the State of California, USA)

California Proposition 65 decal describes the warning messages as required by California Proposition 65.

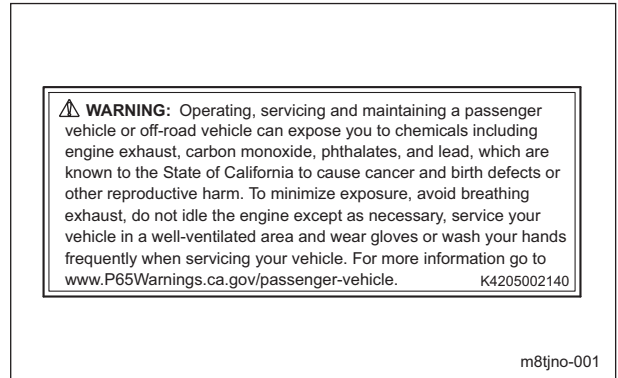

California Proposition 65 Decal (Riding Type)\_001

## Diesel Instruction Mark

(For USA)

Diesel instruction mark describes the type of fuel to be used.

Use Ultra Low Sulfur Diesel Fuel (sulfur-free diesel).

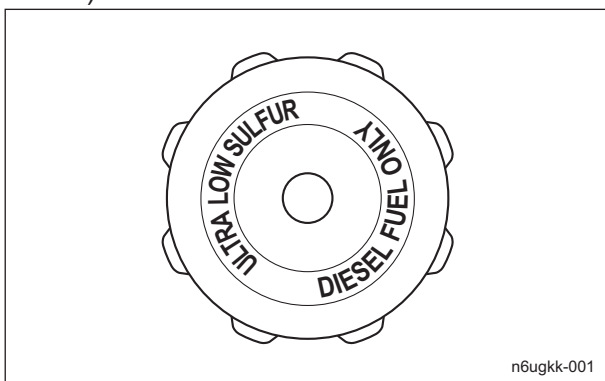

Diesel Instruction Mark\_001

## Spark Arrester Warning Decal

(For the State of California, USA)

Spark arrester warning decal describes the warning messages as required by California Public Resources Code.

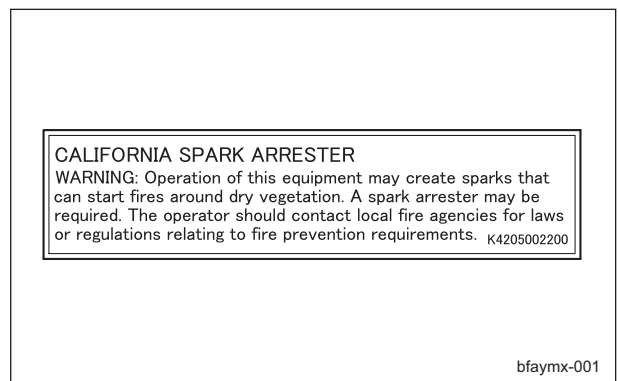

Spark Arrester Warning Decal\_001



## Safety Signs and Instruction Signs

### About Safety Signs and Instruction Signs

**Important**

Safety decals and instruction decals are attached to this product. Make sure that they are preserved in their entirety. If they are damaged, become dirty, or peel off, replace them with new ones.

Part numbers for decals that need to be replaced are listed in the parts catalog. Order them from a Baroness dealer or Kyoisha.

### Positions of Safety Decals and Instruction Decals

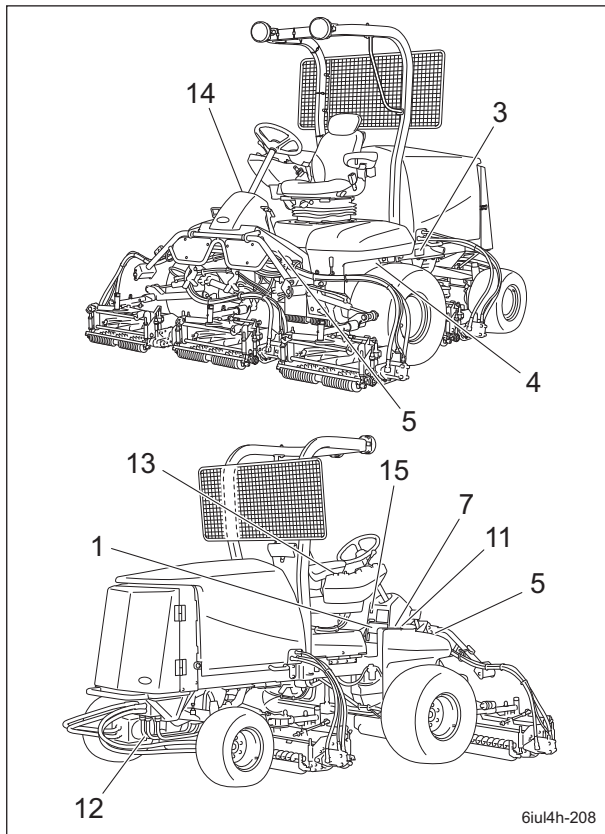

Positions of Safety Decals and Instruction Decals\_001

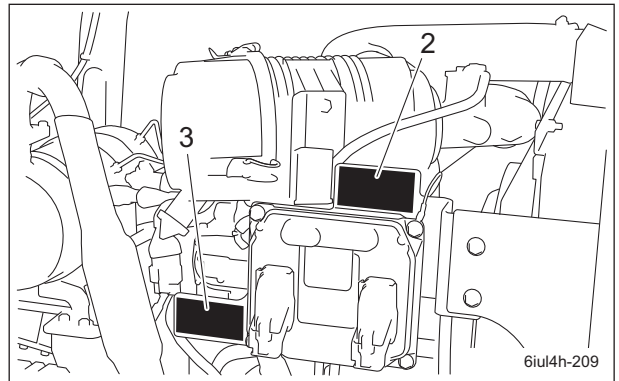

Positions of Safety Decals and Instruction Decals\_002

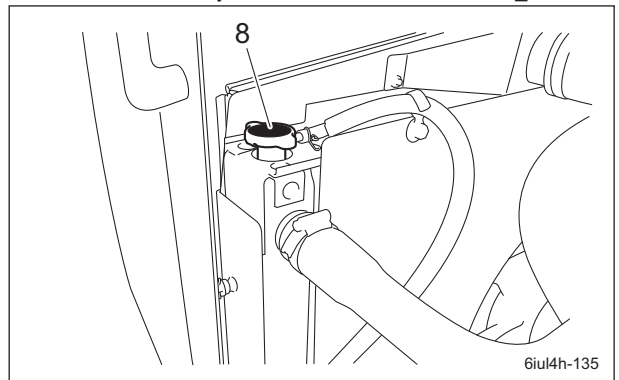

Positions of Safety Decals and Instruction Decals\_003

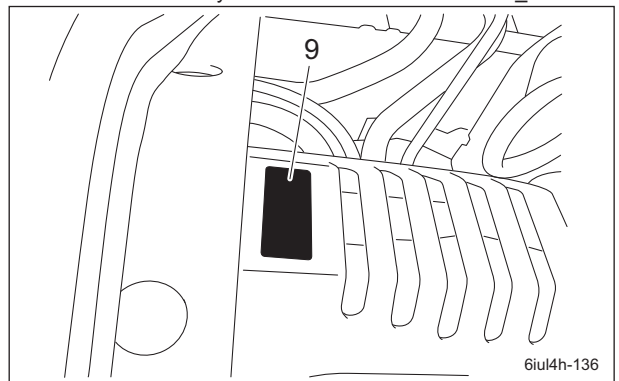

Positions of Safety Decals and Instruction Decals\_004

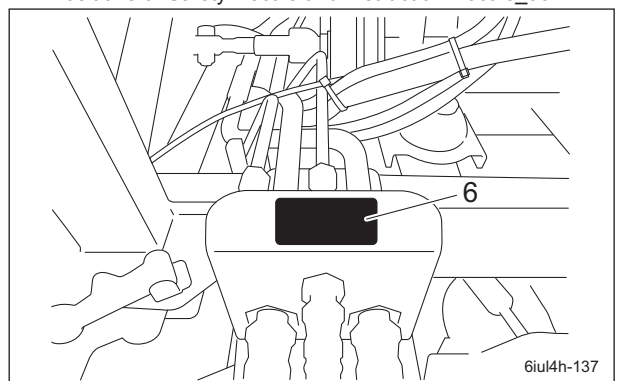

Positions of Safety Decals and Instruction Decals\_005

# Product Overview

---

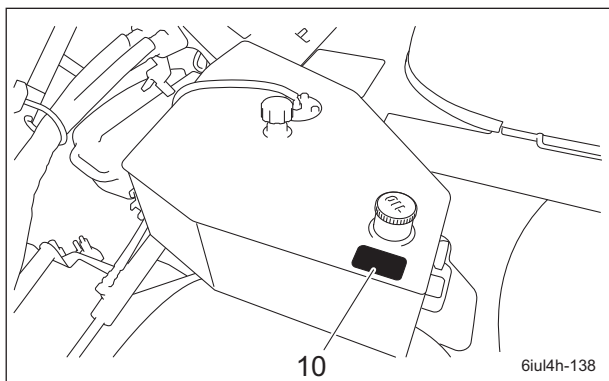

Positions of Safety Decals and Instruction Decals\_006

1	Decal for operation 2
2	Caution to rotating object decal
3	Caution to hot parts decal
4	Caution to injury decal
5	Caution for mower lock decal
6	Caution to getting pinched decal
7	Fire prohibited decal
8	Caution for spouting coolant decal
9	PTO caution decal
10	Hydraulic oil icon
11	Diesel fuel icon
12	DO NOT JACK UP decal
13	DPF regeneration lamp mark
14	Engine warning lamp decal
15	Caution to noise decal

## Description of Safety Decals and Instruction Decals

Decal for Operation (E5)

STICKER, OPERATION (E5)  
LM551B-0604Z0

1.



Read the Owner's Operating Manual.

2.

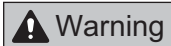

Apply the parking brake, stop the engine, remove the ignition key, and then leave the machine.

3.



Flying objects - Be sure that people around the machine keep a safe distance away.

4.



May cut your hand or leg - Keep hands and feet away from moving parts.

5.



Be careful of exhaust emissions.

6.



Rollover - Do not work on slopes of 15 degrees or more.  
When you descend a slope, lower the mower units and then drive at low speed.  
For ROPS equipped machine, fasten your seatbelt.

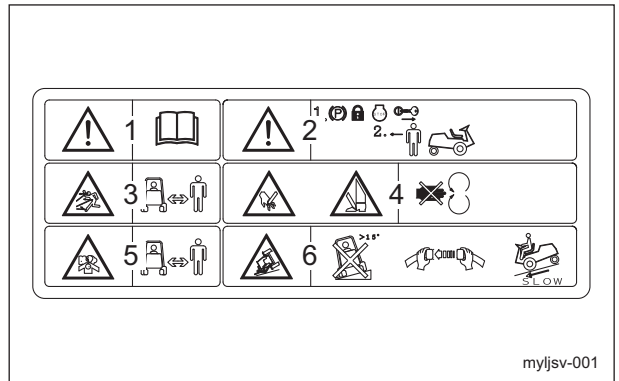

Decal for Operation (E5)\_001

### Caution to Rotating Object Decal

K4205001530

Decal, caution to rotating object



Watch for rotating parts - Keep your hands away from the belts while the engine is running.

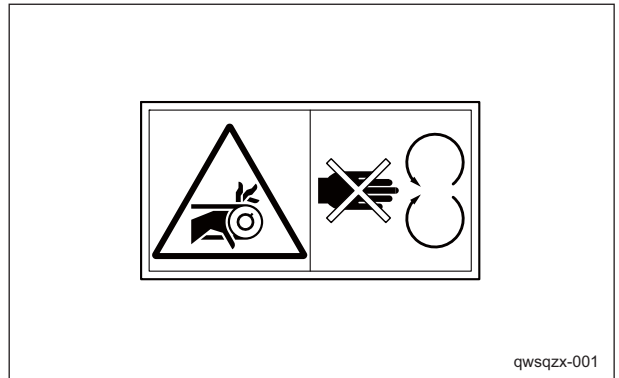

Caution to Rotating Object Decal\_001

# Product Overview

## Caution to Hot Parts Decal

K4205001540

Decal for caution to hot parts

 Caution

High temperature - Do not touch. Otherwise, you will get burned.



xekv4l-001

Caution to Hot Parts Decal\_001

## Caution to Injury Decal

K4205001580

Decal, caution to injure

 Caution

May pinch - There is a risk of being pinched.

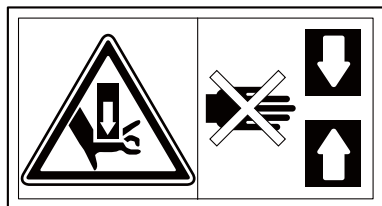

tgp289-001

Caution to Injury Decal\_001

## Caution for Mower Lock Decal

K4205001900

Decal, caution for mower lock

Lock the mower units when traveling or storing with the mower units #4 and 5 raised.



vm5htg-001

Caution for Mower Lock Decal\_001

## Caution to Getting Pinched Decal

K4205001930

Decal, caution to getting pinched

 Caution

May pinch - There is a risk of being pinched.



tgp289-002

Caution to Getting Pinched Decal\_001

## Fire Prohibited Decal

K4205001940  
Decal, fire prohibited

**Warning**  
Keep away from fire.



Fire Prohibited Decal\_001

## Caution for Spouting Coolant Decal

K4205001970  
Decal, caution for spouting coolant

**Caution**  
Caution for spouting coolant - Do not open while hot.  
High temperature - Do not touch. Otherwise, you will get burned.

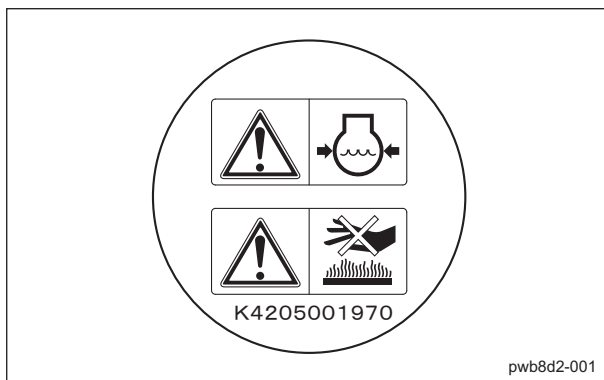

Caution for Spouting Coolant Decal\_001

## PTO Caution Decal

K4205002000  
Decal, caution PTO

**Warning**  
Watch for rotating parts - Keep your hands away from the joints while the engine is running.

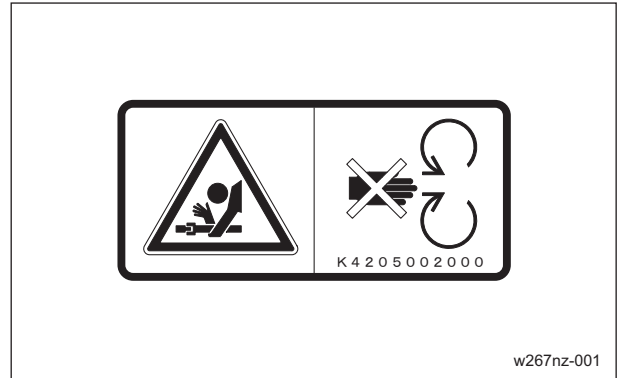

PTO Caution Decal\_001

## Hydraulic Oil Icon

K4209000980  
Hydraulic oil icon  
Read the Owner's Operating Manual.

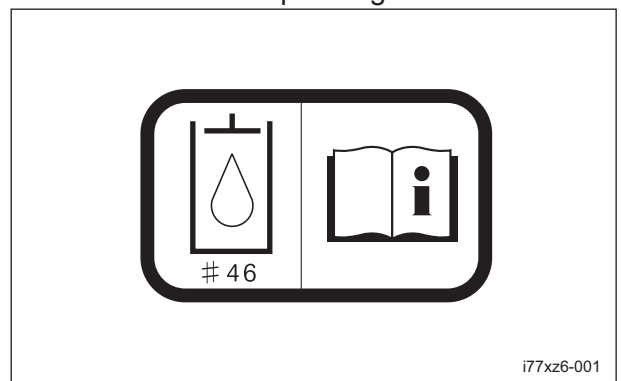

Hydraulic Oil Icon\_001

# Product Overview

## Diesel Fuel Icon

K4209001000  
 Diesel fuel icon  
 Use diesel fuel.

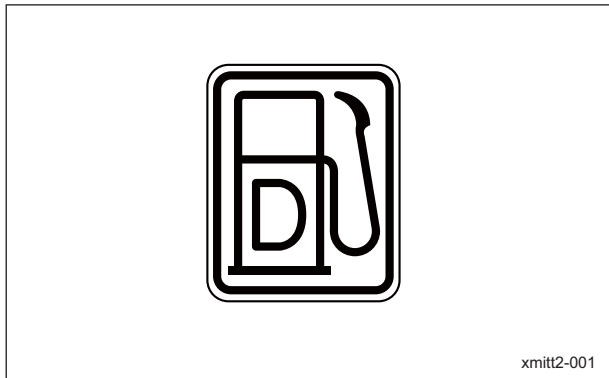

Diesel Fuel Icon\_001

## Engine Warning Lamp Decal

K4205002270  
 Decal, Engine Warning Lamp

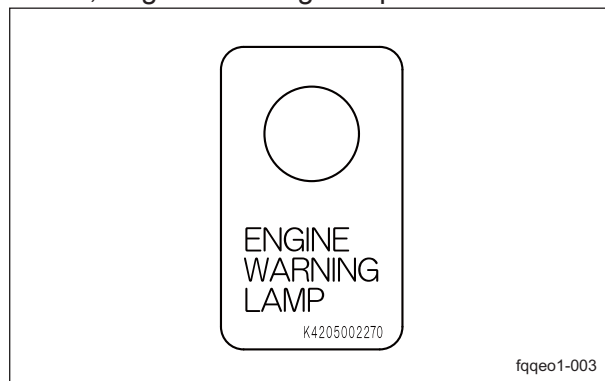

Engine Warning Lamp Decal\_001

## DO NOT JACK UP Decal

K4205002220  
 Decal, DO NOT JACK UP  
 Do not jack up.

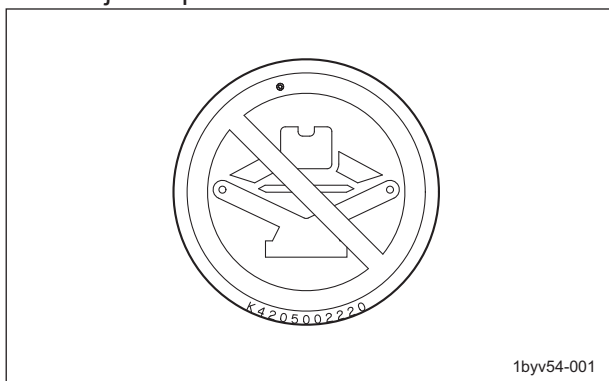

DO NOT JACK UP Decal\_001

## Caution to Noise Decal

K4205002090  
 Decal, caution to noise



Caution to Noise Decal\_001

## DPF Regeneration Lamp Mark

DPF regeneration lamp mark  
 Seek monitor information when the green lamp lighting or blinking.

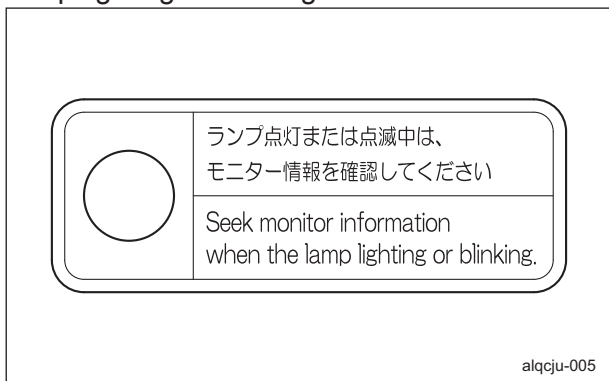

DPF Regeneration Lamp Mark\_001

# Handling Instructions

<b>Inspections</b> .....	<b>Page 4-3</b>	Description of Operation Decals .....	Page 4-27
<b>Daily Check List</b> .....	<b>Page 4-3</b>	Proximity Sensor .....	Page 4-31
Radiator Cover .....	Page 4-4	Relays .....	Page 4-31
Radiator .....	Page 4-4	Light Switch .....	Page 4-32
Coolant .....	Page 4-5	Traveling/Working Selector Switch .....	Page 4-32
Oil Cooler .....	Page 4-6	Reel Rotation Switch .....	Page 4-33
Hydraulic Oil .....	Page 4-7	Reel Forward/Reverse Switch .....	Page 4-33
Hydraulic Hoses .....	Page 4-8	Reel Rotation/Stop Switching Lever .....	Page 4-34
Air Cleaner .....	Page 4-8	Mower Lock Lever (Latch) .....	Page 4-34
Battery .....	Page 4-10	Mower Unit Up/Down Lever .....	Page 4-34
Electrical Wiring .....	Page 4-11	Throttle Knob .....	Page 4-35
Tire .....	Page 4-11	DPF Auto Regeneration Inhibit Switch .....	Page 4-35
Brake .....	Page 4-11	DPF Parked Regeneration Switch .....	Page 4-36
Belt .....	Page 4-11	Traveling Pedal .....	Page 4-36
Wire .....	Page 4-11	Pedal Stopper .....	Page 4-37
Around The Engine .....	Page 4-11	Brake Pedal .....	Page 4-38
Engine Oil .....	Page 4-12	USB Socket .....	Page 4-38
Fuel .....	Page 4-13	Open-Close Lever .....	Page 4-39
Water Separator .....	Page 4-14	Radiator Cover .....	Page 4-39
Fuel Filter .....	Page 4-15	Hood .....	Page 4-39
Oil Leakage .....	Page 4-15	Underseat Cover .....	Page 4-40
Grass Catcher .....	Page 4-15	Step Cover .....	Page 4-40
<b>Tightening Torques</b> .....	<b>Page 4-16</b>	<b>Instruments</b> .....	<b>Page 4-41</b>
Standard Tightening Torques .....	Page 4-16	Description of Monitor .....	Page 4-41
Principal Tightening Torques .....	Page 4-19	Displayed Icon .....	Page 4-41
<b>Adjustment before Work</b> .....	<b>Page 4-20</b>	Main Menu Items .....	Page 4-42
Adjustment of Steering Wheel .....	Page 4-20	DPF Regeneration Lamp .....	Page 4-103
Adjustment of Seat .....	Page 4-20	Engine Warning Lamp .....	Page 4-103
Adjustment of Reel Rotation Control Valves .....	Page 4-21	<b>Move</b> .....	<b>Page 4-104</b>
<b>Procedure to Start/Stop Engine</b> .....	<b>Page 4-23</b>	Traveling Procedure .....	Page 4-104
Start/Stop of Engine .....	Page 4-23	Towing The Machine .....	Page 4-104
Safety Mechanisms .....	Page 4-24	<b>Cutting Work</b> .....	<b>Page 4-105</b>
Warning Mechanisms .....	Page 4-24	Cutting Work .....	Page 4-105
<b>Operation Method</b> .....	<b>Page 4-25</b>	Removal/Installation of Grass Catcher .....	Page 4-106
Cautions for when You Leave The Machine .....	Page 4-25	<b>Transporting</b> .....	<b>Page 4-106</b>
Positions of Operation Decals .....	Page 4-25	Transporting Procedure .....	Page 4-106
		<b>Storage</b> .....	<b>Page 4-106</b>

# Handling Instructions

---

Before Long-Term Storage ..... Page 4-106



# Handling Instructions

## Inspections

Inspect the machine according to the daily check list so that you will be able to take advantage of its optimum performance for a long period of time.

## Daily Check List

LM551B

○ . . . Inspect, adjust, supply, clean

● . . . Replace (first time)

△ . . . Replace

Maintenance Item	Before Work	After Work	Remarks
*1 Check engine oil level and contamination	○		
*1 Check fuel level	○		
*1 Check coolant level	○		
Check hydraulic oil level	○		
Check tire pressures and condition	○		
Check cover condition	○		
Check traveling pedal movement	○		With the engine turned off, make sure that the traveling pedal movement is not heavy and that the pedal returns to the neutral position. Otherwise, check for adhesion of the traveling pedal shaft and abnormality of the traveling cable and trunnion lever.
Check brake function	○		
Check brake pedal movement	○		Make sure that the brake pedal moves 30 mm when applying mild pressure with one hand.
Check oil or water leaks	○		
Check damaged parts	○		
Check tightening bolts and nuts	○		
Check lighting	○		
Check monitor	○		
Check interlock system safety function	○		
Clean radiator cover		○	
Clean radiator core		○	
Clean oil cooler core		○	
Clean machine exterior		○	
Clean engine area		○	

· \*1: Refer to the Engine's Owner's Manual.

# Handling Instructions

## Radiator Cover

### Inspection of Radiator Cover

1. Make sure that there is no damage to the radiator cover.
2. Make sure that the radiator cover is not contaminated.

### Cleaning of Radiator Cover

**Important**

An unclean radiator cover may cause overheating or damage to the engine. It may also cause malfunction of the hydraulic system.

If the radiator cover has been contaminated with dust, be sure to clean it. After operating the machine in a dusty environment, it is important to remove dust from the cover as soon as possible.

1. Open the radiator cover.

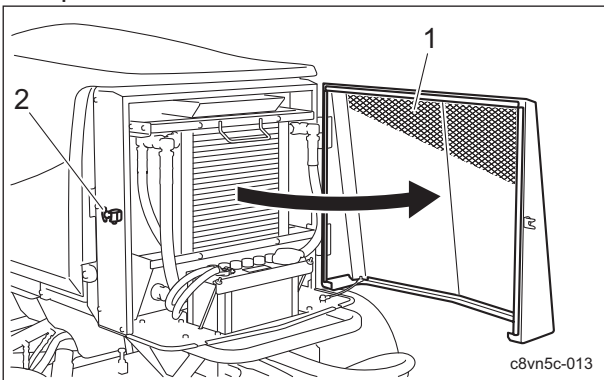

Cleaning of Radiator Cover\_001

1	Radiator cover
2	Rubber catch

2. Carefully clean the front and back of the radiator cover with water or compressed air.

## Radiator

### Inspection of Radiator

1. Make sure that there is no damage to the radiator.
2. Make sure that the radiator is not contaminated.

## Cleaning of Radiator

**Important**

An unclean radiator may cause the engine to overheat or seize. It may also cause malfunction of the hydraulic system.

**Important**

Do not use solid objects, such as a spatula or screwdriver, or high-pressure water to clean the radiator or oil cooler. Otherwise, special fins or tubes may be damaged, possibly resulting in reduced cooling performance or coolant leakage.

If the radiator has been contaminated with dust, be sure to clean it. Especially after operating the machine in a dusty environment, it is important to remove dust as soon as possible.

1. Open the radiator cover.
2. Remove the cotter pin and washer, and then remove the cable.

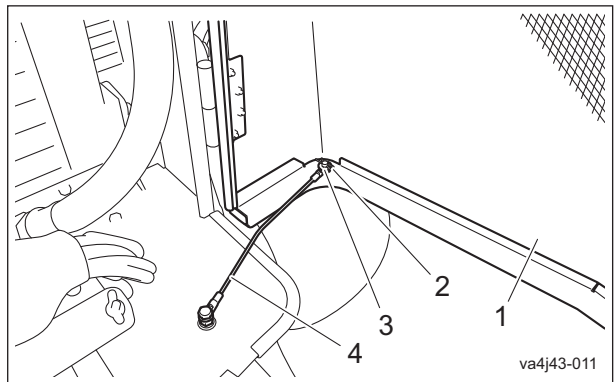

Cleaning of Radiator\_001

1	Radiator cover
2	Cotter pin
3	Washer
4	Cable

# Handling Instructions

3. Pull up the radiator cover to remove it.

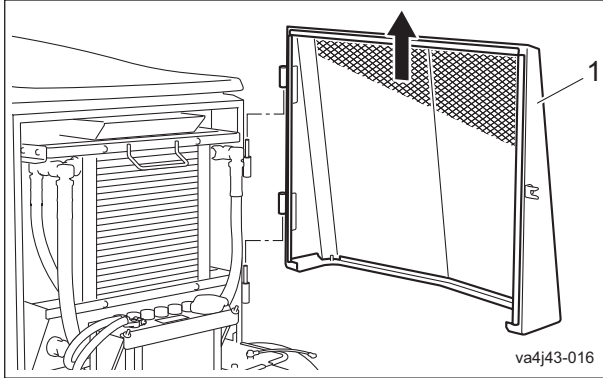

Cleaning of Radiator\_002

1	Radiator cover
---	----------------

4. Unlock the rubber catches on the left and right of the oil cooler, and then tilt the oil cooler.

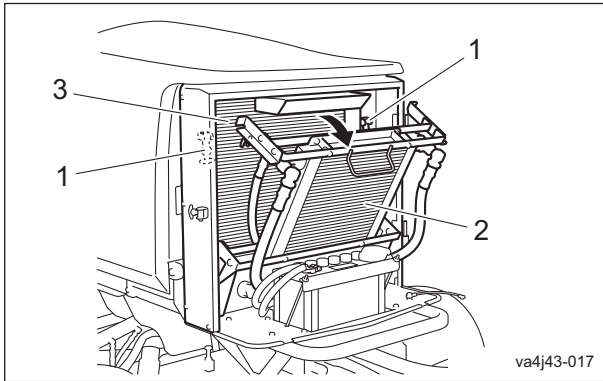

Cleaning of Radiator\_003

1	Rubber catch
2	Oil cooler
3	Radiator

5. Carefully clean the radiator with water or compressed air.

6. Open the hood.

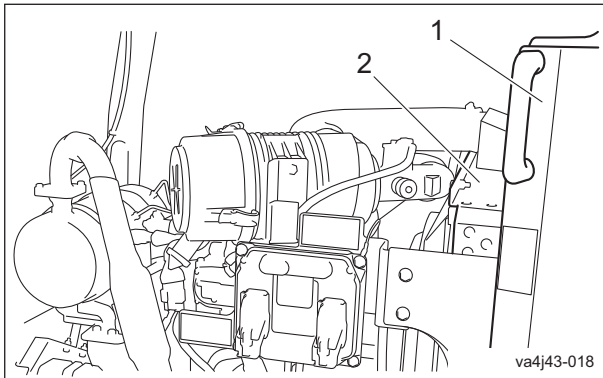

Cleaning of Radiator\_004

1	Hood
2	Radiator

7. Carefully clean the radiator with water or compressed air.

## Coolant

### Inspection of Coolant

**⚠ Caution**

Do not touch the radiator or coolant during engine operation or immediately after the engine has been turned off. Otherwise, you may get burned.

**⚠ Caution**

Inspection should take place after the engine has well cooled down.

1. Make sure that the coolant level in the reserve tank is between "FULL" and "LOW".

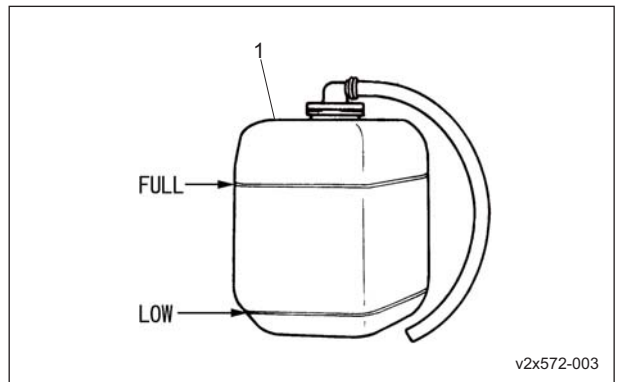

Inspection of Coolant\_001

1	Reserve tank
---	--------------

# Handling Instructions

## Coolant Supply

1	Reserve tank
2	Reserve tank cap

**Caution**

Do not touch the radiator or coolant during engine operation or immediately after the engine has been turned off. Otherwise, you may get burned.

**Caution**

Supply coolant after the engine has well cooled down.

**Caution**

The radiator cap is pressurized. If you remove the radiator cap while the engine is overheated, hot steam will burst out, possibly resulting in burns. Make sure that the water temperature and pressure are reduced, and then grab the cap with a thick cloth and gradually open the cap.

**Important**

When supplying coolant, be sure to use clean water.

**Important**

Tightly close the radiator cap. If the cap is loose or incorrectly installed, the engine will be overheated due to water leakage, resulting in engine damage.

1. If the coolant level in the reserve tank is lower than the "LOW" mark, open the reserve tank cap, and then supply clean water up to the "FULL" mark.

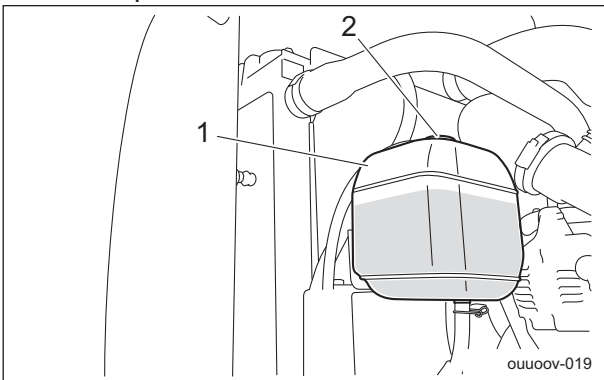

Coolant Supply\_001

2. If no coolant is in the reserve tank, follow the steps below to supply clean water.
  - [1] Open the radiator cap, and then supply clean water up to the opening.
  - [2] Open the reserve tank cap, and then supply clean water up to the "FULL" mark.

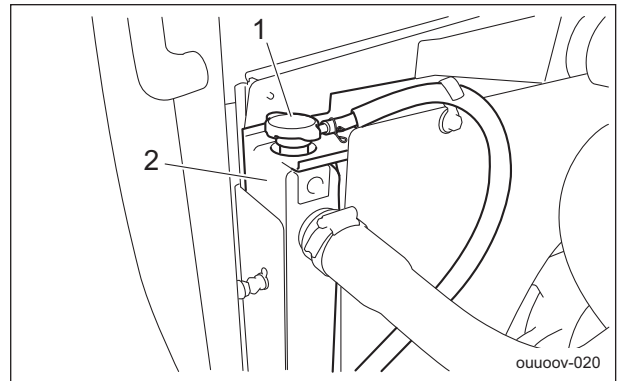

Coolant Supply\_002

1	Radiator cap
2	Radiator

## Oil Cooler

### Inspection of Oil Cooler

1. Make sure that there is no damage to the oil cooler.
2. Make sure that the oil cooler is not contaminated.

### Cleaning of Oil Cooler

**Important**

An unclean oil cooler may cause malfunction of the hydraulic system.

**Important**

Do not use solid objects, such as a spatula or screwdriver, or high-pressure water to clean the radiator or oil cooler. Otherwise, special fins or tubes may be damaged, possibly resulting in reduced cooling performance or coolant leakage.

# Handling Instructions

If the oil cooler has been contaminated with dust, be sure to clean it. Especially after operating the machine in a dusty environment, it is important to remove dust as soon as possible.

1. Open the radiator cover.
2. Unlock the rubber catches on the left and right of the oil cooler, and then tilt the oil cooler.

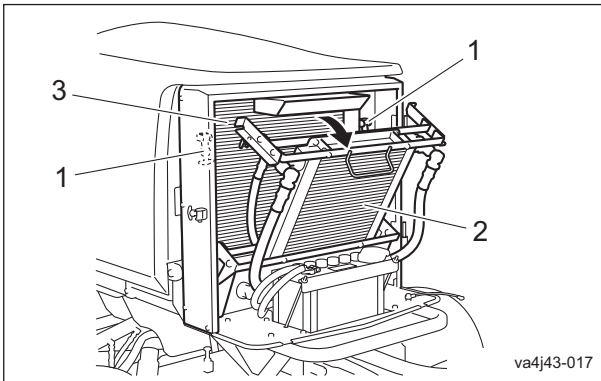

Cleaning of Oil Cooler\_001

1	Rubber catch
2	Oil cooler
3	Radiator

3. Carefully clean the front and back of the oil cooler with water or compressed air.

## Hydraulic Oil

### Inspection of Hydraulic Oil

The oil gauge is on the side of the hydraulic tank.

1. Raise the mower units and maintain that position on a level surface.
2. Make sure that the oil level is at the middle of the oil gauge.

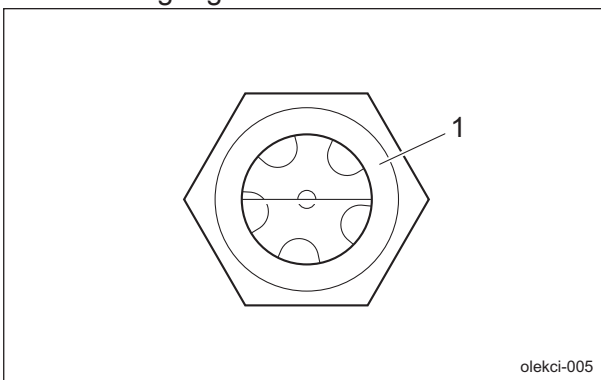

Inspection of Hydraulic Oil\_001

1	Oil gauge
---	-----------

3. Check underneath the machine for oil leakage.

### Supply of Hydraulic Oil

**Important**

Do not mix different types of oil.

**Important**

Use Shell Tellus S2M46 (or equivalent) as hydraulic oil. In case of an equivalent, consult Characteristics of Hydraulic Oil and use hydraulic oil whose characteristics are superior to those of the specific hydraulic oil. Especially regarding kinematic viscosity and viscosity index, use of hydraulic oil whose figures are less than those of the specified hydraulic oil will cause a malfunction in the hydraulic circuit.

**Note:**

### Characteristics of Hydraulic Oil

Specified Hydraulic Oil	Shell Tellus S2M46	
ISO Viscosity Grade	ISO VG46	
Density	15 °C (59 °F)	0.873 g/cm <sup>3</sup> (0.0315 lb/in <sup>3</sup> )
API Gravity	30.6	
Flash Point (Open Cup)	230 °C (446 °F)	
Pour Point	-30 °C (-22 °F)	
Kinematic	40 °C (104 °F)	46 mm <sup>2</sup> /s (46 cSt)
Viscosity	100 °C (212 °F)	7 mm <sup>2</sup> /s (7 cSt)
Viscosity Index	109	

1. Remove the screws from the tank cover, and then remove the tank cover.

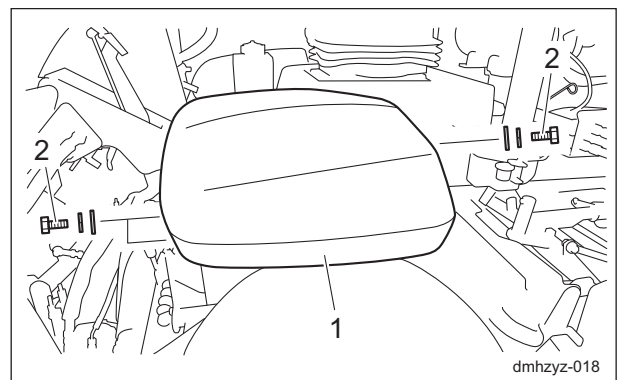

Supply of Hydraulic Oil\_001

1	Tank cover
2	Screw

# Handling Instructions

2. If the hydraulic oil level is low, follow the steps below to supply oil.

[1] Open the tank cap, and then supply hydraulic oil through the oil filling port until the oil level reaches the middle of the oil gauge on the hydraulic tank.

[2] Tighten the tank cap securely.

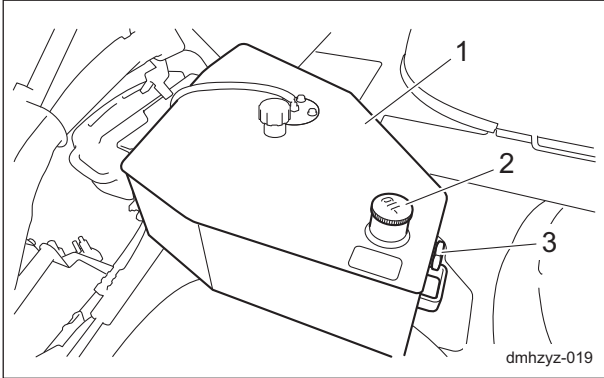

Supply of Hydraulic Oil\_002

1	Hydraulic tank
2	Tank cap
3	Oil gauge

3. Start the engine, raise and lower the mower units, and turn the steering wheel right and left.

Move forward and reverse repeatedly several times.

4. Raise the mower units and maintain that position on a level surface, and then check to see if the oil level is at the middle of the oil gauge. If necessary, supply oil.

5. Check underneath the machine for hydraulic oil leakage.

6. Install the tank cover.

## Hydraulic Hoses

### Inspection of Hydraulic Hoses

#### **Warning**

When checking the hydraulic circuit for pinhole leaks or oil leakage from nozzles, do not use your hands. Use items such as paper or corrugated cardboard to find leakage points.

Be extremely careful with high-pressure oil as it may pierce your skin, resulting in personal accidents.

If fluid is injected into the skin it must be surgically removed within a few hours by a doctor familiar with this form of injury or gangrene may result.

Check the pipes and hoses to make sure that there is no oil leakage, circuit damage, looseness, wear, connector looseness, weather deterioration and chemical deterioration.

Make any necessary repairs before operating the machine.

## Air Cleaner

### Inspection of Air Cleaner

The air cleaner is a component that removes dirt from the intake air to prevent wear of the cylinder liners and piston rings so that the engine will always operate smoothly.

A contaminated air cleaner element may cause malfunction of the engine.

1. Inspect the air cleaner by checking the indicator.

If the air cleaner element is contaminated, the indicator will display a red ring.

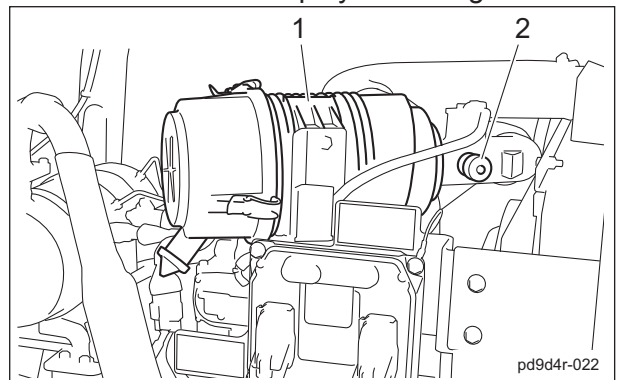

Inspection of Air Cleaner\_001

# Handling Instructions

1	Air cleaner
2	Indicator

2. Make sure that there is no damage to the air cleaner.
3. Make sure that the air cleaner element is not contaminated.

## Cleaning of Air Cleaner

**Caution**

Implement after the engine and DPF etc. have well cooled down.  
Otherwise you may get burned.

A contaminated air cleaner element may cause malfunction of the engine.  
To maximize the life of the engine, clean the air cleaner properly.

**Important**

The inner element cannot be cleaned.

1. Follow the steps below to clean the outer element.
  - [1] Remove the clips from the three locations, remove the air cleaner cap, and then remove the outer element.
  - [2] While paying close attention not to damage the outer element, tap a solid portion of the outer element or blow compressed air from its inside to remove dust and dirt.  
If the outer element is extremely contaminated, replace it with a new one.
  - [3] Attach the outer element to the air cleaner body.
  - [4] Replace the air cleaner cap, and then fix it securely using the clips.

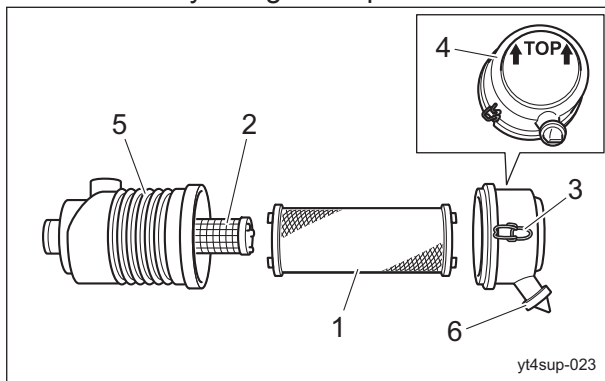

Cleaning of Air Cleaner\_001

1	Outer element
2	Inner element
3	Clip
4	Air cleaner cap
5	Air cleaner body
6	Evacuator valve

2. Press the reset button of the indicator.

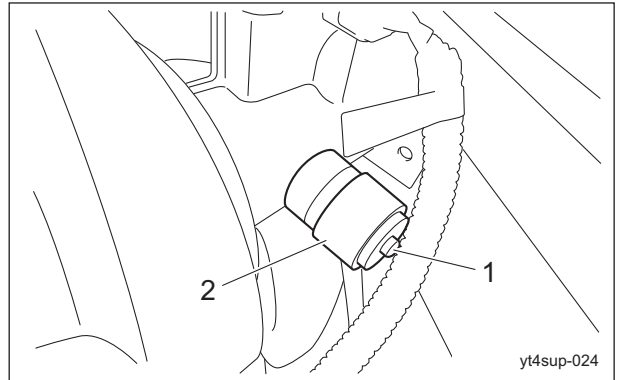

Cleaning of Air Cleaner\_002

1	Reset button
2	Indicator

# Handling Instructions

## Battery

### Inspection of Battery

**Danger**

Keep away from fire while inspecting or charging the battery.  
The battery may explode.

**Warning**

Do not allow the battery fluid level to become lower than the LOWER LEVEL (minimum fluid level line).  
The battery may explode if it is used or charged while the battery fluid level is at the LOWER LEVEL (minimum fluid level line).

**Caution**

Implement after the engine and DPF etc. have well cooled down.  
Otherwise, you may get burned.

1. Open the radiator cover.

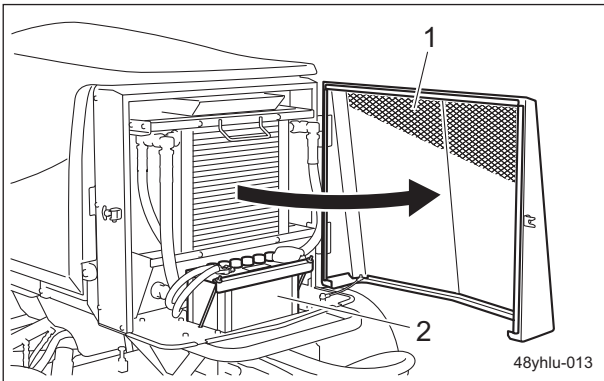

Inspection of Battery\_001

1	Radiator cover
2	Battery

- Clean the areas around the battery fluid level lines using a cloth dampened with water.
- Make sure that the battery fluid level is between the UPPER LEVEL (maximum fluid level line) and the LOWER LEVEL (minimum fluid level line).

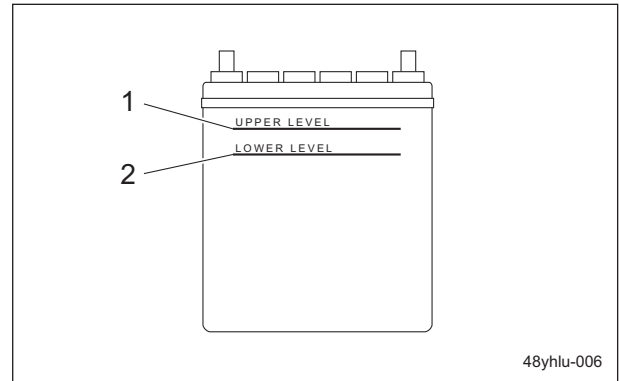

48yhlu-006

Inspection of Battery\_002

1	UPPER LEVEL
2	LOWER LEVEL

### Supply of Battery Fluid

**Danger**

Be careful not to let your skin, eyes or clothes, etc., come into contact with the battery fluid or accidentally swallow the fluid.  
Should your skin or clothes come into contact with the battery fluid, immediately wash them away with water.

**Danger**

When you supply battery fluid, wear protective garments and safety glasses, etc.

**Caution**

Implement after the engine and DPF etc. have well cooled down.  
Otherwise you may get burned.

- If the battery fluid level is lower than halfway between the UPPER LEVEL (maximum) line and LOWER LEVEL (minimum) line, add purified water up to the UPPER LEVEL (maximum) line.

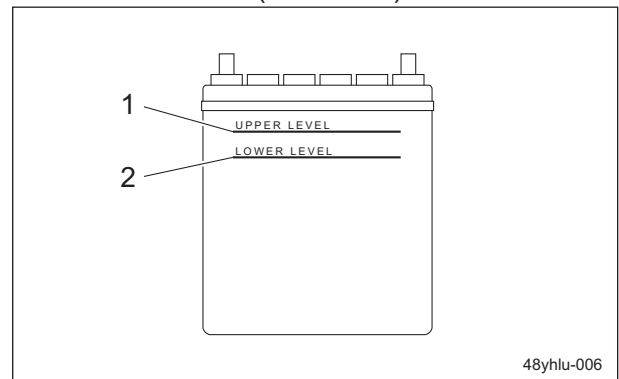

48yhlu-006

Supply of Battery Fluid\_001



# Handling Instructions

1	UPPER LEVEL
2	LOWER LEVEL

## Electrical Wiring

### Inspection of Electrical Wiring

**Important**

Electrical short circuit will cause fire, electrical leakage and malfunction of electrical equipments.

Inspect electrical wiring for poor terminal connections, damaged wiring or terminals, loose connections, weather-related deterioration and chemical-related deterioration.

If necessary, repair before operating the machine.

## Tire

### Inspection of Tires

1. Check the pneumatic pressure of the tires.
2. Make sure that there are no cracks, damage or abnormal wear.

	Tire size	Pneumatic pressure
Front wheel	26.5 x 14.00-12	120 kPa (1.2 kgf/cm <sup>2</sup> )
Rear wheel	20 x 12.00-10	140 kPa (1.4 kgf/cm <sup>2</sup> )

## Brake

### Inspection of Brake Pedal

1. When depressing the brake pedal fully, make sure that there is appropriate clearance between the floorboard and the pedal or pedal reserve distance.
2. When depressing the brake pedal fully, make sure that the pedal reaction is not spongy and that there is no noise.
3. When depressing the brake pedal during traveling, make sure that the machine stops smoothly and the braking is sufficiently effective.

### Inspection of Parking Brake

1. Depress the locking pedal while firmly depressing the brake pedal to lock it and check that the brake is applied effectively.

2. Firmly depress the brake pedal and release the locking pedal to release the brake pedal, and then check that the brake is not applied.

## Belt

### Inspection of Belt

**Warning**

The engine must be stopped when the belt is inspected.

**Important**

A slacking or damaged belt or damaged fan may cause overheating or lack of a battery charge.

1. Press the middle of the belt with your finger to check the belt tension.
2. Make sure that there are no cracks, damage or abnormal wear.

## Wire

### Inspection of Wire

1. Make sure that the wire is not cracked or damaged.
2. If the wire is cracked or damaged, replace it with a new one immediately.

## Around The Engine

### Inspection of Engine-Associated Parts

**Caution**

Implement after the engine and DPF etc. have well cooled down. Otherwise you may get burned.

1. Check the fuel system parts for loosened or cracked joints and leakage. Replace the parts if necessary.
2. Blow compressed air to clean any grass or flammable materials that may be attached on or around the DPF. Remove clippings and dust in a gap thoroughly due to the intricately shaped engine.

# Handling Instructions

## Engine Oil

### Inspection of Engine Oil

**Important**

Securely tighten the oil level gauge and oil filler cap.

1. Check the oil level 10 to 20 minutes after stopping the engine.
2. Position the machine so that the engine is level, and then fully insert the oil level gauge to check the oil level.

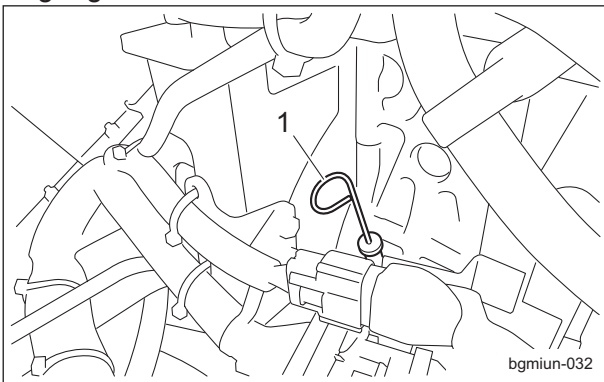

Inspection of Engine Oil\_001

1	Oil level gauge
---	-----------------

3. The appropriate oil level should be between the upper and lower limit lines on the gauge.

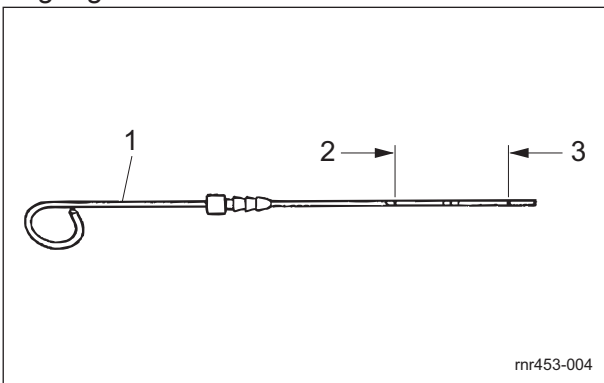

Inspection of Engine Oil\_002

1	Oil level gauge
2	Upper limit
3	Lower limit

### Supply of Engine Oil

**Important**

Do not supply too much engine oil. Otherwise, the engine may be damaged.

**Important**

Do not mix different types of engine oil.

**Important**

Be sure to use engine oil that is classified as JASO standard:DH-2 or API Service Grade: CJ-4, with an SAE Viscosity that is appropriate for the operating environment (ambient temperature).

**Important**

Securely tighten the oil level gauge and oil filler cap.

1. Engine oil is supplied through the oil filler cap.  
Remove the oil filler cap, and then supply new engine oil until the oil reaches a level in between the upper and lower limit lines on the oil level gauge.
2. Securely install the oil filler cap.

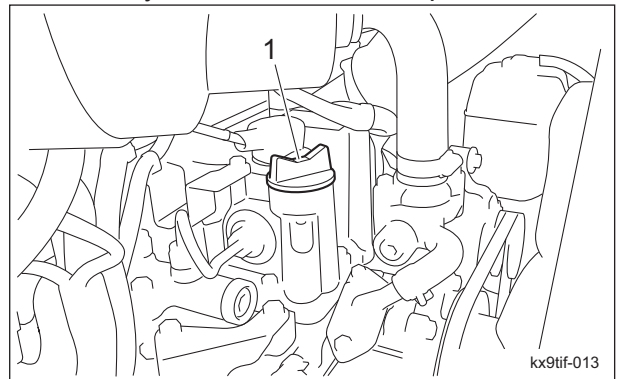

Supply of Engine Oil\_001

1	Oil filler cap
---	----------------

3. It will take a while for the supplied engine oil to descend into the oil pan.  
Check the oil level again 10 to 20 minutes after replenishment.

# Handling Instructions

## Fuel

### Inspection of Fuel Quantity

With the machine on a level surface, observe the fuel level in the monitor to check the fuel level.

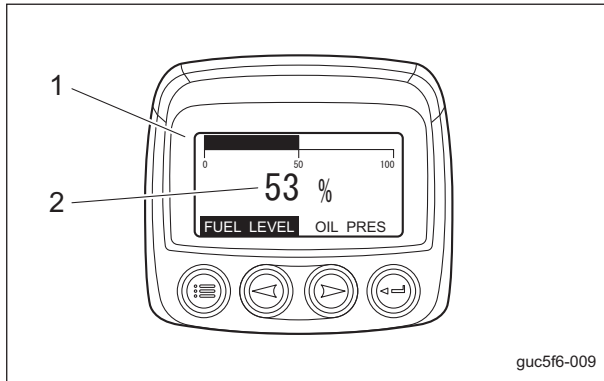

Inspection of Fuel Quantity\_001

1	Monitor
2	Fuel level

**Note:**

The factory default low fuel level is 10%. The level can be changed optionally.

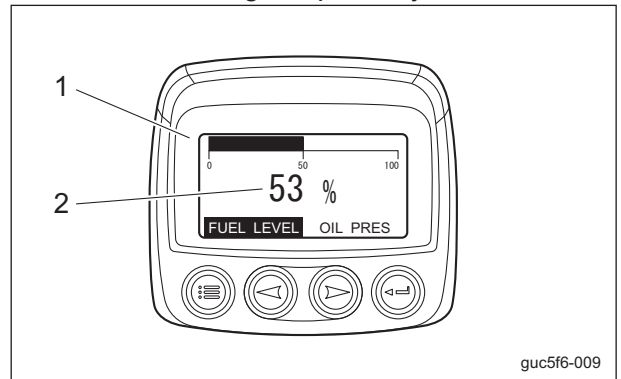

Fuel Supply\_001

1	Monitor
2	Fuel level

### Fuel Supply

**Warning**

Do not supply additional fuel after the fuel level indicates 100%.  
If you supply too much fuel, it might overflow from the fuel cap when you travel or work on a slope.

**Warning**

Keep fire away while refueling.  
Do not smoke.

**Important**

Use ultra-low sulfur diesel fuel (sulfur-free diesel fuel).

**Important**

In case of lack of fuel, DPF regeneration can not be performed.

If the monitor displays the warning message "FUEL LEVEL LOW", immediately stop operation, and then supply fuel (diesel). The fuel tank capacity is approximately 51.0 dm<sup>3</sup> (51.0 L).

### Air Bleeding of Fuel System

**Important**

The air-bleed plug should always be in the closed position except during the air bleeding operation.  
Using the machine with the air-bleed plug in the open position may cause the engine to stall.

This machine has a function of automatic air bleeding.  
However, depending on the mechanical structure, it may not bleed air completely.  
If the automatic air bleeding does not work well, follow the steps below to perform manual air bleeding.

**Caution**

Do not perform air bleeding when the engine is hot since a fire might occur.

1. Set the ignition key to the "ON" position.
2. Turn the air-bleed plug on the fuel filter several times to loosen it.
3. When a bubble no longer arises, screw the air-bleed plug to the original position.
4. Set the ignition key to the "OFF" position.

# Handling Instructions

5. Wipe off the spilt oil thoroughly.

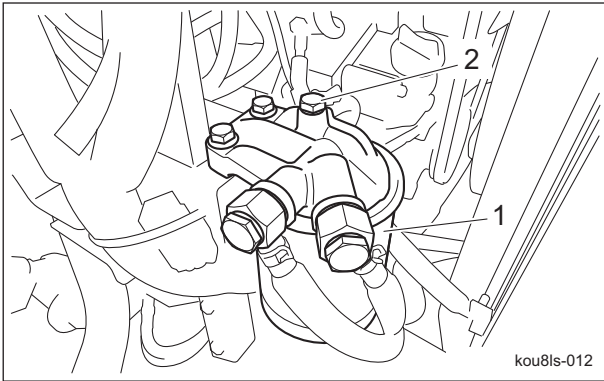

Air Bleeding of Fuel System\_001

1	Fuel filter
2	Air-bleed plug

## Water Separator

### Inspection of Water Separator

**Important**

If water contaminates the fuel, the supply pump and injector will seize due to heat.

The water separator removes water from the fuel.

1. Make sure that debris and water have not accumulated in the cup. With the float raised, water incorporation is confirmed.

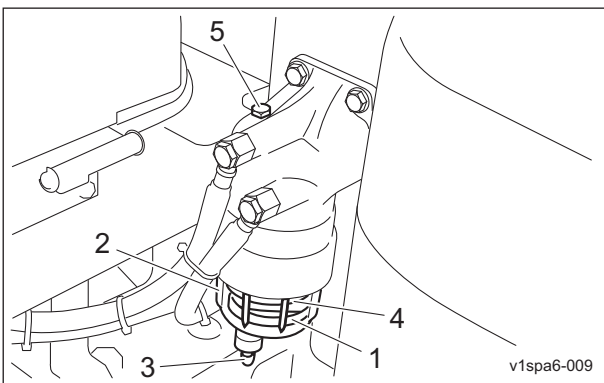

Inspection of Water Separator\_001

1	Float
2	Cup
3	Water drain plug
4	Element
5	Air-bleeding bolt

### Draining of Water Separator

**Important**

If water contaminates the fuel, the supply pump and injector will seize due to heat.

Drain the water in accordance with the Maintenance Schedule.

However, when the float is raised by water, drain the water even before the schedule.

1. Follow the steps below to drain the water.

[1] Stop the engine, and then turn the key switch to the "OFF" position.

[2] Place a container under the water separator.

[3] Loosen the water drain plug and air-bleeding bolt to drain the water into the container.

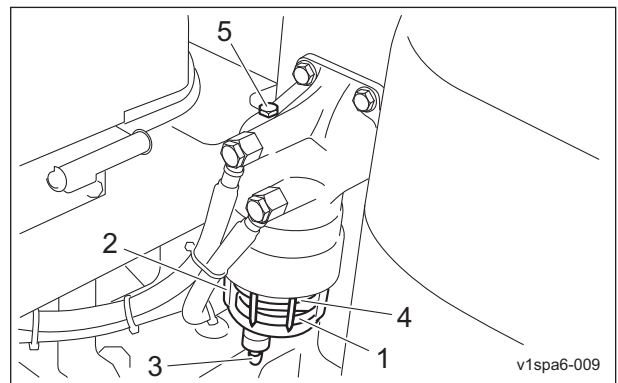

Draining of Water Separator\_001

1	Float
2	Cup
3	Water drain plug
4	Element
5	Air-bleeding bolt

[4] Tighten the water drain plug and air-bleeding bolt.

[5] Bleed air from the fuel system.

# Handling Instructions

## Cleaning of Water Separator

**Important**

If water contaminates the fuel, the supply pump and injector will seize due to heat.

Clean the water separator in accordance with the Maintenance Schedule. However, when debris has accumulated in the cup, clean it even before the schedule.

1. Follow the steps below to clean the water separator.
  - [1] Stop the engine, and then turn the key switch to the "OFF" position.
  - [2] Place a container under the water separator.
  - [3] Remove and clean the cup, element and float. Replace the element with a new one when replacement needed.

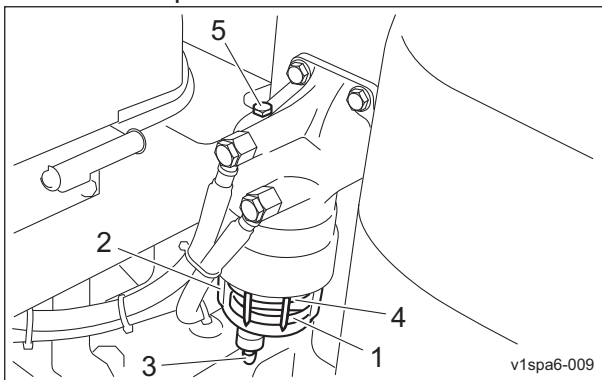

Cleaning of Water Separator\_001

1	Float
2	Cup
3	Water drain plug
4	Element
5	Air-bleeding bolt

- [4] Install the cup, element and float in their original positions.
- [5] Bleed air from the fuel system.

## Fuel Filter

### Inspection of Fuel Filter

The fuel filter works to remove foreign objects mixed into the fuel. When the fuel flow becomes insufficient, replace the fuel filter if necessary.

1. Make sure that there is no fuel leakage.

2. Make sure that the fuel filter is not damaged or dirty.

## Oil Leakage

### Inspection of Oil Leakage

**Caution**

When performing maintenance on the hydraulic system, lower the mower units.

After approximately 50 hours of operation, some tightened portions may be loosened and oil and grease may leak. Be sure to retighten the parts. Check the bottom of the machine for oil and grease leakage.

## Grass Catcher

### Inspection of Grass Catcher

The grass catcher may no longer correctly collect grass clippings due to its wear, damage, deformation, etc., caused by frequent use.

1. Make sure that there is no wear or deterioration of the grass catcher.
2. Make sure that there is no damage to the grass catcher.
3. Make sure that there is no interference to moving parts due to deformation of the grass catcher.

# Handling Instructions

---

## Tightening Torques

**Important**

Refer to the Tightening Torque table.  
Note that the Baroness product warranty may not apply to defects caused by incorrect or overtorque tightening, etc.

## Standard Tightening Torques

### Bolts and Nuts

**Important**

A number of bolts are used in each part of this machine.  
Be sure to re-tighten the bolts and nuts, because they may be loosened at the earlier stage of the use.

As to the bolts and nuts without any special instruction, tighten them in appropriate tightening torque with proper tool.

Too much tightening may cause the looseness or damage of the screw.

The strength of tightening is determined by types of screws, strength, the friction of thread face or base face and others.

The table below is for the galvanized or parkerized bolts.

In case that the strength of internal thread is weak, it is not applied.

Do not use rusty or sand attached "screw."

Otherwise, it may cause insufficient tightening even if you apply the specified tightening torque.

The friction of the screw face becomes higher and the tightening torque is canceled out by the friction, therefore sufficient tightening cannot be applied.

If "screw" is wet by water or oil, do not tighten it with normal tightening torque.

If the screw is wet, the torque coefficient will get smaller and it may result in too much tightening.

Too much tightening may cause looseness by the screw stretched or result in damage.

Do not use a bolt experienced too much burden.



Using the impact wrench requires the skill.

Do exercise as much as possible for steady tightening.

# Handling Instructions

Handling Instructions

Nominal diameter	General bolt		
	Strength classification 4.8		
	 tib3yb-001		
	N-m	kgf-cm	lb-in
M5	3 - 5	30.59 - 50.99	26.55 - 44.26
M6	7 - 9	71.38 - 91.77	61.96 - 79.66
M8	14 - 19	142.76 - 193.74	123.91 - 168.17
M10	29 - 38	295.71 - 387.49	256.68 - 336.34
M12	52 - 67	530.24 - 683.20	460.25 - 593.02
M14	70 - 94	713.79 - 958.52	619.57 - 831.99
M16	88 - 112	897.34 - 1142.06	778.89 - 991.31
M18	116 - 144	1,182.85 - 1,468.37	1,026.72 - 1,274.54
M20	147 - 183	1,498.96 - 1,866.05	1,301.10 - 1,619.73
M22	295	3,008.12	2,611.05
M24	370	3,772.89	3,274.87
M27	550	5,608.35	4,868.05
M30	740	7,545.78	6,549.74

Nominal diameter	Heat-treated bolt					
	Strength classification 8.8			Strength classification 10.9		
	 tib3yb-002			 tib3yb-003		
	N-m	kgf-cm	lb-in	N-m	kgf-cm	lb-in
M5	5 - 7	50.99 - 71.38	44.26 - 61.96	7 - 10	71.38 - 101.97	61.96 - 88.51
M6	8 - 11	81.58 - 112.17	70.81 - 97.36	14 - 18	142.76 - 183.55	123.91 - 159.32
M8	23 - 29	234.53 - 295.71	203.57 - 256.68	28 - 38	285.52 - 387.49	247.83 - 336.34
M10	45 - 57	458.87 - 581.23	398.30 - 504.51	58 - 76	591.43 - 774.97	513.36 - 672.68
M12	67 - 85	683.20 - 866.75	593.02 - 752.34	104 - 134	1,060.49 - 1,366.40	920.50 - 1186.03
M14	106 - 134	1,080.88 - 1,366.40	938.21 - 1,186.03	140 - 188	1,427.58 - 1,917.04	1,239.14 - 1,663.99
M16	152 - 188	1,549.94 - 1,917.04	1,345.35 - 1,663.99	210 - 260	2,141.37 - 2,651.22	1,858.71 - 2,301.26
M18	200 - 240	2,039.40 - 2,447.28	1,770.20 - 2,124.24	280 - 340	2,855.16 - 3,466.98	2,478.28 - 3,009.34
M20	245 - 295	2,498.27 - 3,008.12	2,168.50 - 2,611.05	370 - 450	3,772.89 - 4,588.65	3,274.87 - 3,982.95
M22	-	-	-	530	5,404.41	4,691.03
M24	-	-	-	670	6,831.99	5,930.17
M27	-	-	-	1,000	10,197.00	8,851.00
M30	-	-	-	1,340	14,628.78	11,860.34

**Note:**  
The same values are applied to "fine screw thread."

# Handling Instructions

---

## Hydraulic Hose

The tightening torques for union joints and union adaptors with parallel pipe threads (G, PF) are shown in the table below.

A union joint or adaptor will not become loose or leak as long as it is tightened by the specified torque.

If fluid leaks from the sealed portion, do not attempt to tighten the union joint or adaptor forcibly.

Examine whether any foreign matter or scratches are present on the seat surface.

Tightening a union joint or adaptor forcibly could damage the connection of the joints.

When tightening a union joint or adaptor, use a torque wrench where possible and firmly tighten it by an appropriate torque.

Nominal diameter of the hose size	Nominal diameter of the parallel pipe threads (PF)	Tightening torque		
		N-m	kgf-cm	lb-in
6	1/4	24.50	250	221.28
9	3/8	49.03	500	564.91
12	1/2	58.84	600	677.89
15	3/4	117.68	1200	1,355.78
19	3/4	117.68	1200	1,355.78
25	1	137.30	1400	1,581.74
32	1-1/4	166.72	1700	1,920.69
38	1-1/2	205.94	2100	2,372.61
50	2	245.17	2500	2,824.54

## Fittings with Parallel Threads (O-Ring Seal Type)

The tightening torques for fittings with parallel threads (O-ring seal method) are shown in the table below.

Tightening the fitting forcibly with a spanner or other such tool to secure it to a set position could damage the fitting, its washers, and other parts. Be sure to tighten the fitting to the torque appropriate to its size.

Nominal diameter of thread	Tightening torque		
	N-m	kgf-cm	lb-in.
1/4	34.32 - 49.03	350 - 500	309.79 - 442.55
3/8	68.65 - 78.45	700 - 800	619.57 - 708.08
1/2	98.07 - 117.68	1000 - 1200	885.10 - 1,062.12
3/4	147.10 - 176.52	1500 - 1800	1,327.65 - 1,593.18
1	245.17 - 274.59	2500 - 2800	2,212.75 - 2,478.28
1-1/4	294.20	3000	2,655.30
1-1/2	294.20	3000	2,655.30
2	392.27	4000	3,540.40



# Handling Instructions

## Principal Tightening Torques

### Tightening Torque by Model

LM551

LM551A

LM551B

Tighten the following bolts and nuts at the torque specified in the table.

For thread locking adhesive, apply a middle strength thread locker (ThreeBond 1322 or equivalent anaerobic sealant).

Location		Code	Part name	Tightening torque			Thread locking adhesive
				N-m	kgf-cm	lb-in	
Front wheel	Motor	K0013120702	BOLT, HT M12-70	104 - 134	1,060.49 - 1,366.40	920.50 - 1186.03	—
	Wheel mounting base	-	Slotted nut 1-20UNEF of hydraulic motor	280 - 300	2,855.16 - 3,059.10	2,478.28 - 2,655.30	—
	Wheel	K0011120352	BOLT, P1.5 M12-35	110	1121.69	973.61	—
Rear wheel	Motor	K0010120602	BOLT, HT M12-60	104 - 134	1,060.49 - 1,366.40	920.50 - 1186.03	—
	Wheel mounting base	-	Slotted nut 1-20UNEF of hydraulic motor	280 - 300	2,855.16 - 3,059.10	2,478.28 - 2,655.30	—
	Wheel	K0011120352	BOLT, P1.5 M12-35	110	1121.69	973.61	—
Engine		K0017100252	BOLT, SMALL HT P1.25 M10-25	58 - 76	591.43 - 774.97	513.36 - 774.97	—
		K0010121201	BOLT, HT M12-120	67 - 85	683.20 - 886.75	593.02 - 752.34	—
		K3680000030	M3.5 Screw (accessories)	0.78 - 1.18	7.95 - 12.03	6.90 - 10.44	—
Joint		K001A100401	BOLT, 13T W/HEX HOLE M10-40	62 - 72	632.21 - 734.18	632.21 - 734.18	○
		K0011100252	BOLT, HT P1.25 M10-25	58 - 76	591.43 - 774.97	513.36 - 774.97	—
Tie rod		- (K1610000020)	Slotted nut(END ASSY, TIE-ROD MALE (RH))	45	458.87	398.30	—
		- (K1611000020)	Slotted nut(END ASSY, TIE-ROD MALE (LH))	45	458.87	398.30	—
Piston pump		K0013140452	BOLT, HT M14-45	106 - 134	1080.88 - 1366.4	938.21 - 1186.03	—
Cross valve		K0013101202	BOLT, HT M10-120	29 - 38	295.71 - 387.49	256.68 - 336.34	—
Seat		- (K1700000430)	M8 Bolt and Nut (accessories)	-	-	-	○
Mower stopper		K0041060122	SCREW, + FLAT HEAD M6-12	-	-	-	○
ROPS		K001A121101	BOLT, 13T W/HEX HOLE M12-110	104 - 134	1,060.49 - 1,366.40	920.50 - 1186.03	—

# Handling Instructions

## Adjustment before Work

### Adjustment of Steering Wheel

**Warning**

Do not make adjustments while traveling since doing so is dangerous.

**Caution**

Be sure the steering wheel position is securely locked. If it becomes loose while traveling, an unexpected accident may occur.

The steering wheel can be adjusted up or down.

Adjust the position to fit the operator.

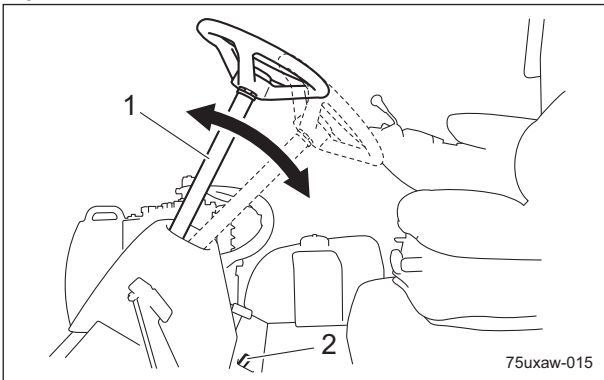

Adjustment of Steering Wheel\_001

1	Steering
2	Tilt lever

Shift the tilt lever to the "FREE" position, move the steering wheel to the position that suits the work requirements, and then shift the tilt lever to the "LOCK" position to secure the steering wheel in place.

The tilt lever is located in the driver's left foot area.

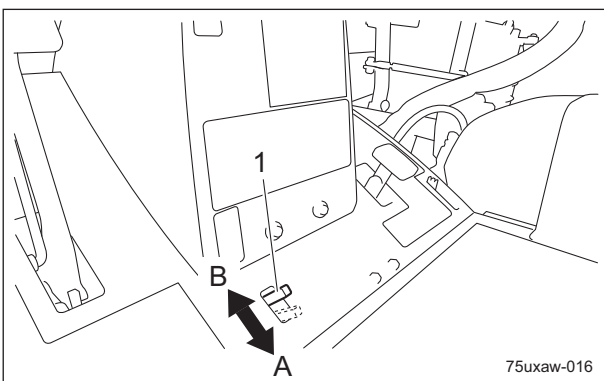

Adjustment of Steering Wheel\_002

1	Tilt lever
A	FREE (released)
B	LOCK (locked)

### Adjustment of Seat

Use the adjustment levers to adjust the seat. Adjust the position to fit the operator.

1. Use the forward/backward adjustment lever to adjust the seat back and forth.
2. Use the tilt adjustment lever to adjust the angle of the backrest.
3. Turn the suspension adjustment handle to adjust the firmness of the seat suspension. Refer to the suspension indicator while making adjustments. [45 to 130 kg (99.2 to 286.6 lb)]
4. Turn the armrest adjustment knob to adjust the angle of the armrests.
5. Turn the seat height adjustment knob to adjust the height of the seat steplessly. [0 to 60 mm (0 to 2.36 in)]

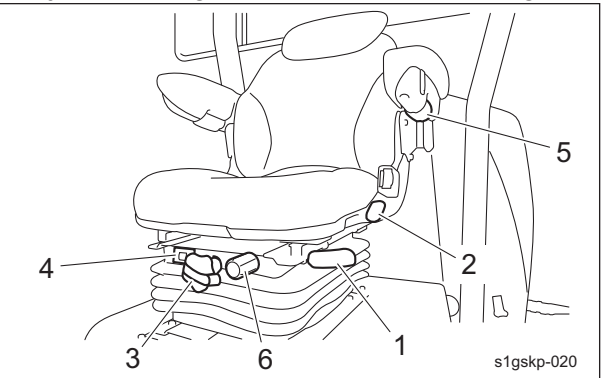

Adjustment of Seat\_001

1	Forward/backward adjustment lever
2	Tilt adjustment lever
3	Suspension adjustment handle
4	Suspension indicator
5	Armrest adjustment knob
6	Seat height adjustment knob

# Handling Instructions

## Adjustment of Reel Rotation Control Valves

The reel rotation control valves adjust the rotation speeds of the reel cutters (cutting cylinders).

Adjust according to the operating conditions. A label listing dial settings for corresponding reel rotation speeds is attached.

Adjust the reel rotation control valve to the setting for the reel rotation speed listed on the reel rotation indicating decal.

"TURNS" means the rotation number of the dial's counterclockwise rotation started from the state where the dial is fully tightened clockwise.

"POS" means the dial decal number pointed by the indicating screw.

Note:

The factory default reel rotation speed is set to 1,450 rpm.

LH6* / LS6*			LH52		
TURNS	POS	REEL SPEED	TURNS	POS	REEL SPEED
2	6	1,150	1	7	1,250
	8	1,250		8	1,350
3	2	1,350	2	1	1,450
	4	1,450		2	1,550
	6	1,500		3	1,700

FOR 0 (STARTING POS) TURN CW TO MAX POS

96fzvf-005

Adjustment of Reel Rotation Control Valves\_001

1. Stop the engine.
2. Open the underseat cover.
3. Use the specialized wrench (accessory) to loosen the lock nut for the dial.

Note:

Raise the lock nut to a position where it will not interfere when the dial is turned.

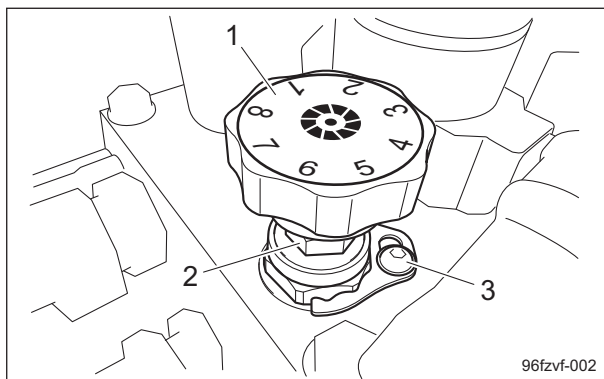

Adjustment of Reel Rotation Control Valves\_002

1	Dial
2	Lock nut
3	Indicating screw

### Important

In order to maintain quality mowing, the reel rotation speed must be the same for all mower units.

4. Turn the dial to set it to the appropriate position.  
Set the two dials to the same position.

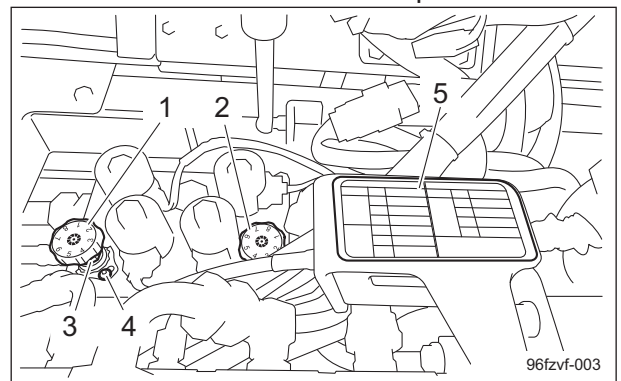

Adjustment of Reel Rotation Control Valves\_003

1	Dial (mower units #1, #4 and #5)
2	Dial (mower units #2 and #3)
3	Lock nut
4	Indicating screw
5	Reel rotation indicating decal

5. Tighten the lock nut for the dial.  
If the dial rotation number is unknown, follow the steps below to adjust the dial.

1. Stop the engine.
2. Open the underseat cover.
3. Use the specialized wrench (accessory) to loosen the lock nut for the dial.

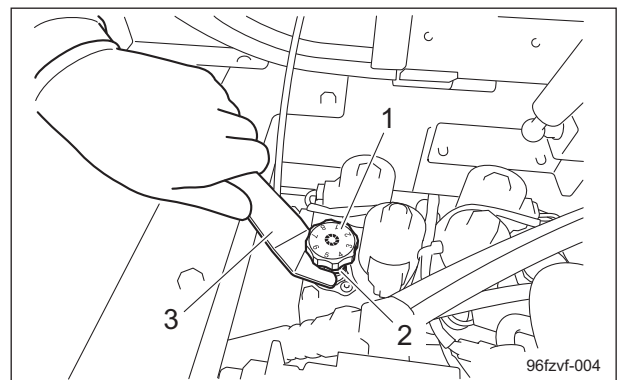

Adjustment of Reel Rotation Control Valves\_004

# Handling Instructions

1	Dial (mower units #1, #4 and #5)
2	Lock nut
3	Specialized wrench (accessory)

**Note:**

Raise the lock nut to a position where it will not interfere when the dial is turned.

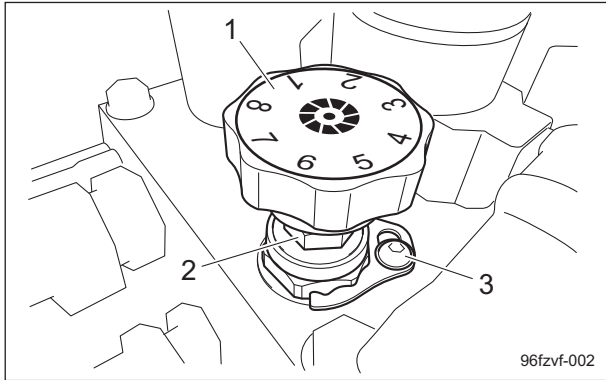

Adjustment of Reel Rotation Control Valves\_005

1	Dial
2	Lock nut
3	Indicating screw

4. Turn the dial clockwise until it stops.
5. Turn the dial counterclockwise to set it to the appropriate position.  
The amount that the dial is turned differs depending on the mower unit.  
For example, the following procedures show the steps to set the reel rotation speed to 1,450 rpm.

When mower unit LS62 or LS66/LH62 is installed:

Turn the dial counterclockwise three times, then an additional 180 degrees. Position "4" on the dial sticker should be aligned with the center of the indicating screw.

When mower unit LH52 is installed:

Turn the dial counterclockwise two times, then an additional 45 degrees.

Position "1" on the dial sticker should be aligned with the center of the indicating screw.

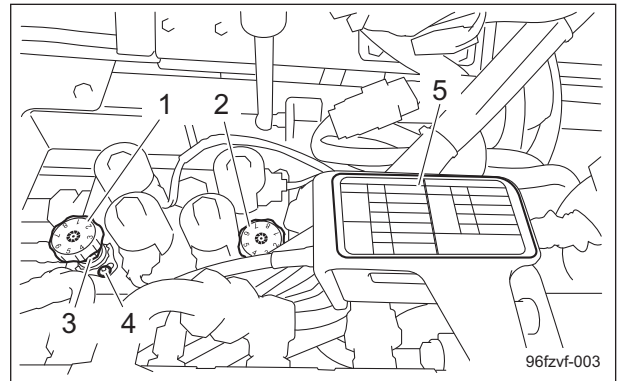

Adjustment of Reel Rotation Control Valves\_006

1	Dial for mower units #1, #4 and #5
2	Dial for mower units #2 and #3
3	Lock nut
4	Indicating screw
5	Reel rotation indicating decal

6. Use the specialized wrench (accessory) to tighten the lock nut for the dial.

# Handling Instructions

## Procedure to Start/Stop Engine

### Start/Stop of Engine

#### Procedure to Start Engine

**Caution**

Before starting the engine, make sure that there are no other people or obstacles around the machine.

**Caution**

Be careful of the mower units lowering when the mower unit up/down lever is shifted to the "Down" position and the key switch is turned to the "ON" position while the engine is stopped with the traveling/working selector switch set to the "Working" position.

**Important**

Starter operation must take 15 seconds or less.  
If the engine still does not start, stop using the battery for 30 to 60 seconds to avoid exhausting the battery.

1. Sit on the seat.
2. Make sure that you have depressed the brake pedal and applied the parking brake.
3. Make sure that the reel rotation switch is set to the "Stop" position.
4. Make sure that the mower unit up/down lever is set to the neutral position.
5. Make sure that the traveling pedal is in neutral position.
6. Move the throttle knob from the "Low speed" position halfway toward the "High speed" position.

7. Switch the ignition key to the "ON (HEATER)" position.

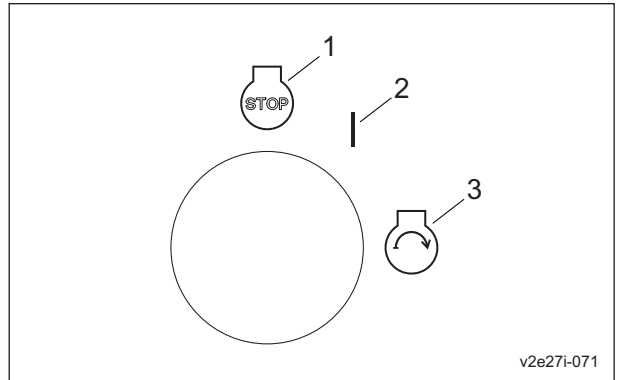

Procedure to Start Engine\_001

1	OFF
2	ON (HEATER)
3	START

**Caution**

When the ignition key is switched to the "ON" position, "Warming up" may appear in the monitor display.  
Do not start the engine until the message disappears.

8. Make sure that the intake heater is generating heat, the "BARONESS" logo or "Warming up" message appears in the monitor display, and the yellow and red LEDs are lit.

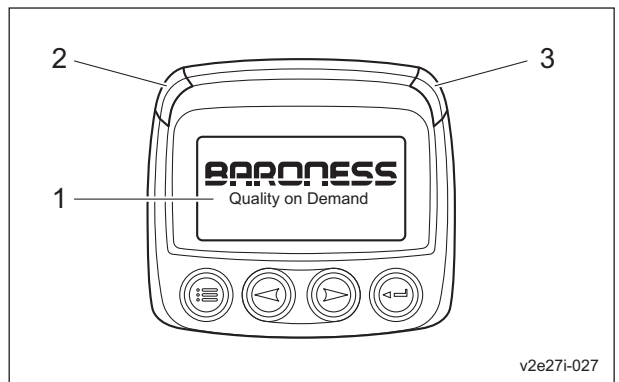

Procedure to Start Engine\_002

1	Monitor display
2	Yellow LED
3	Red LED

# Handling Instructions

## Caution

Quickly returning the ignition key from the "START" position to the "ON" position may result in damage to the machine.

9. After the "BARONESS" logo and the yellow and red LEDs go off and the parameters (items and values such as the rotation speed) appear, immediately set the ignition key to the "START" position.
10. When the starter starts rotating and the engine starts, slowly return the ignition key to the "ON" position.
11. Move the throttle knob to the "Low speed" position, and then warm up the engine for 1-2 minutes.
12. Gradually move the throttle knob toward the "High speed" position.

## Procedure to Stop Engine

## Danger

Since it will become extremely hot around the exhaust outlet during DPF regeneration, do not perform the regeneration in a location where fires may occur.

## Important

Do not stop the engine with the DPF regeneration lamp (LED) turned on.

1. Set the traveling pedal to the neutral position.
2. Depress the brake pedal, and then apply the parking brake.
3. Set the reel rotation switch to the "Stop" position.
4. Raise all the mower units.
5. Make sure that the DPF regeneration lamp and the DPF regeneration icon are not lighted.
6. Switch the ignition key to the "OFF" position.
7. Make sure that the engine has stopped.
8. Remove the ignition key.
9. Leave the driver's seat.
10. Close the fuel cock of the water separator.

## Safety Mechanisms

This machine features a safety device for starting/stopping the engine.

1. As for starting the engine, the safety device prevents the engine from starting unless it meets each of the following four conditions.
  - An operator is sitting on the seat.
  - The parking brake is applied.
  - The reel rotation switch is set to the "OFF" position.
  - The traveling pedal is set to the neutral position.

## Important

When you restart the engine after the safety device stops the engine, be sure to return the ignition key to the "OFF" position first, and then restart it.

Otherwise the engine does not start.

2. In the event the operator leaves the seat with the parking brake applied and the engine running, the safety device will be activated and will stop the engine under any of the following conditions:
  - The traveling pedal is not set to the neutral position. (The operator has depressed the traveling pedal.)
  - The reel rotation switch is set to the "Rotate" position.  
However, when the reel reverse switch is set to the "ON" position (reverse rotation), the engine does not stop.

## Warning Mechanisms

This machine features various warning mechanisms.

1. Overheat Warning Buzzer  
If the water temperature inside the engine exceeds 110 degrees Celsius, a buzzer will sound. (intermittent tone)
2. Hydraulic Oil Level Warning Buzzer  
If the oil level in the hydraulic tank decreases by approximately 3.0 dm<sup>3</sup> (3.0 L) from the specified level, a buzzer will sound. (continuous tone)

# Handling Instructions

### 3. Engine Overload Warning Buzzer

If the traveling pedal is depressed and the speed exceeds 12.0 km/h while the pedal stopper is in the "Traveling" position and the reel cutters (cutting cylinders) are rotating, a buzzer will sound. (intermittent tone)

### 4. Warning Buzzer for Traveling With Brake Applied

If the traveling pedal is depressed while the parking brake is applied, a buzzer will sound. (continuous tone)

#### Warning Buzzer

There are two warning buzzers, which indicate four warnings.

- Warning buzzer 1 & 2
- Warning buzzer 3 & 4

#### 1. Overheat Warning Buzzer

If the water temperature inside the engine exceeds 110 degrees Celsius, a buzzer will sound. (intermittent tone)

When the buzzer sounds, stop the engine immediately, and then inspect the machine and perform any necessary maintenance.

#### 2. Hydraulic Oil Level Warning Buzzer

If the oil level in the hydraulic tank decreases by approximately 3.0 dm<sup>3</sup> (3.0 L) from the specified level, a buzzer will sound. (continuous tone)

When the buzzer sounds, stop the engine immediately, and then inspect the machine and perform any necessary maintenance.

#### 3. Engine Overload Warning Buzzer

If the traveling pedal is depressed and the speed exceeds 12.0 km/h while the pedal stopper is in the "Traveling" position and the reel cutters (cutting cylinders) are rotating, a buzzer will sound. (intermittent tone)

When the buzzer sounds, stop the engine immediately and set the pedal stopper to the "Working" position.

#### 4. Warning Buzzer for Traveling With Brake Applied

If the traveling pedal is depressed while the brake pedal is locked with the locking pedal, a buzzer will sound. (continuous tone)

When the buzzer sounds, firmly depress the brake pedal to release the locking pedal.

## Operation Method

### Cautions for when You Leave The Machine

#### ⚠ Caution

If the brakes are not sufficiently effective, use the wheel stoppers to secure the machine.

#### ⚠ Caution

Never park the machine on a slope.

1. Park the machine on level ground.
2. Apply the parking brake.
3. Stop the engine.
4. Remove the ignition key.
5. Leave the machine.

### Positions of Operation Decals

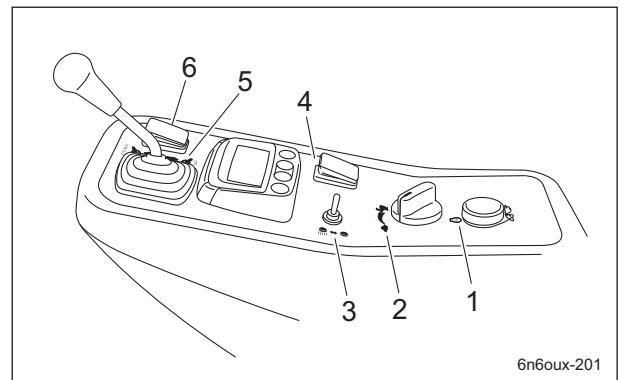

Positions of Operation Decals\_001

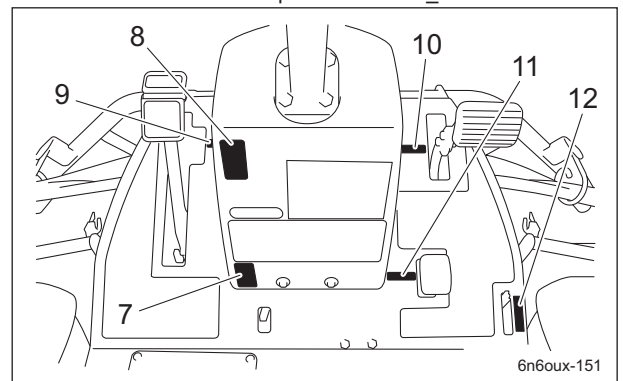

Positions of Operation Decals\_002

# Handling Instructions

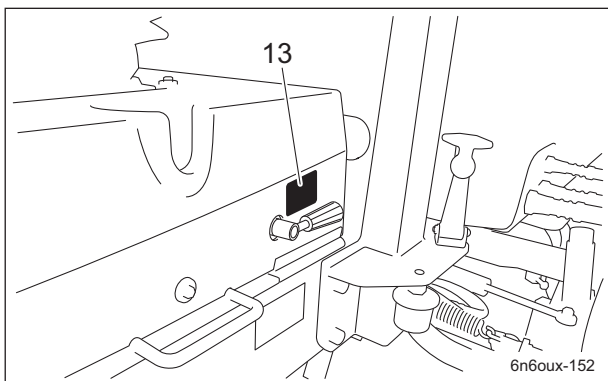

Positions of Operation Decals\_003

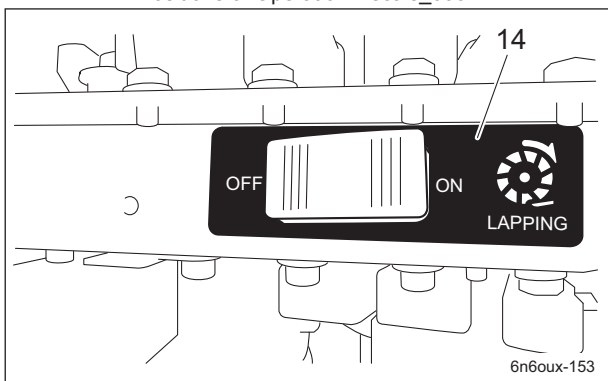

Positions of Operation Decals\_004

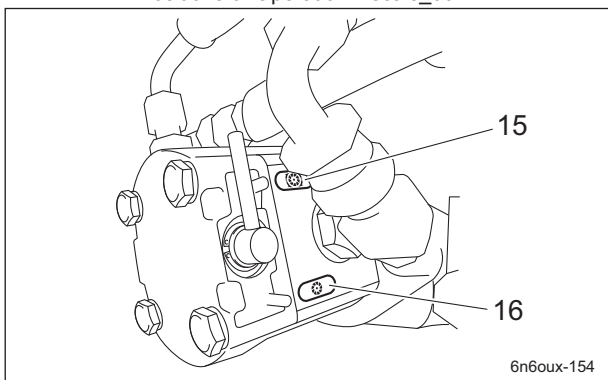

Positions of Operation Decals\_005

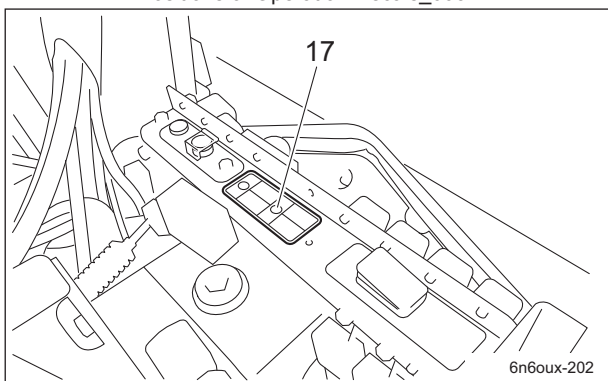

Positions of Operation Decals\_006

1	Key switch decal
2	Engine rotation mark
3	Light switch mark
4	Reel rotation switch mark
5	Mower unit up/down lever decal
6	Traveling/working selector mark
7	Tilt steering decal
8	Parking brake decal
9	BRAKE decal
10	FORWARD decal
11	BACKWARD decal
12	Driving mode shift decal
13	Lever open/close decal
14	Lapping decal
15	Reel rotation decal
16	Reel stop decal
17	DPF switch decal



# Handling Instructions

## Description of Operation Decals

### Key Switch Decal

Decal, key switch  
This indicates the key switch positions.

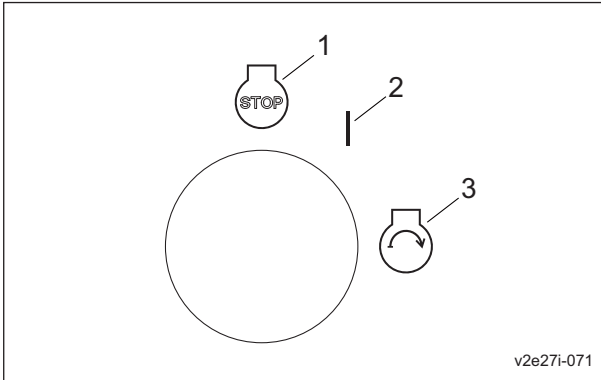

Key Switch Decal\_001

1	OFF
2	ON (HEATER)
3	START

### Light Switch Mark

Note:  
Depending on the specifications, this function may not be available.  
Light switch mark  
It illustrates ON/OFF of the light.

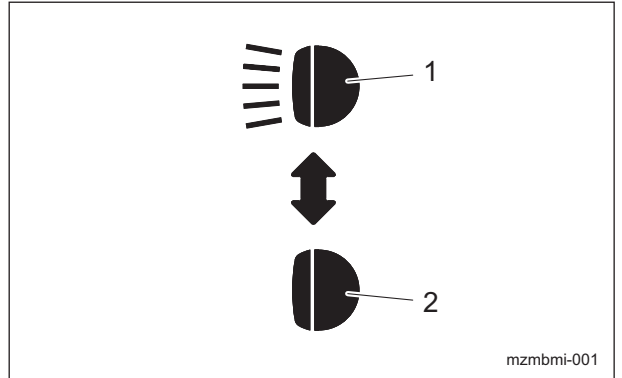

Light Switch Mark\_001

1	ON
2	OFF

### Engine Rotation Mark

Engine rotation mark  
This indicates low/high speed of engine rotation.

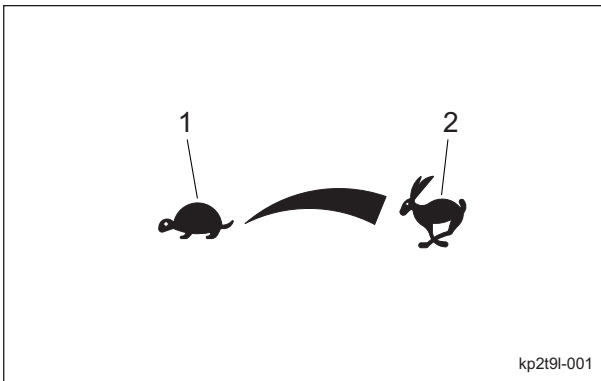

Engine Rotation Mark\_001

1	Low speed
2	High speed

### Reel Rotation Mark

Reel rotation mark  
It illustrates Rotation/Stop of the reel cutter (cutting cylinder).

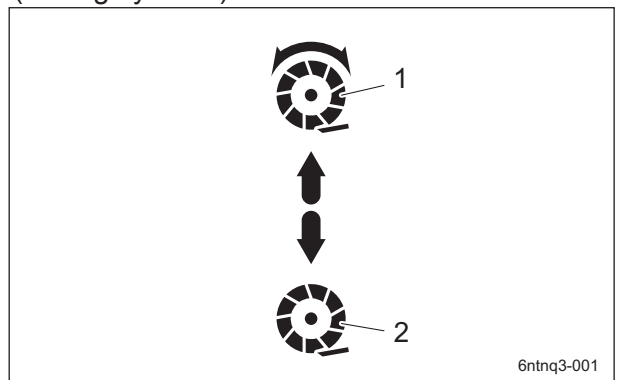

Reel Rotation Mark\_001

1	Rotation
2	Stop

# Handling Instructions

## Mower Unit Up/Down Decal

Decal, mower unit up/down  
This indicates the Up/Down positions of the mower unit.

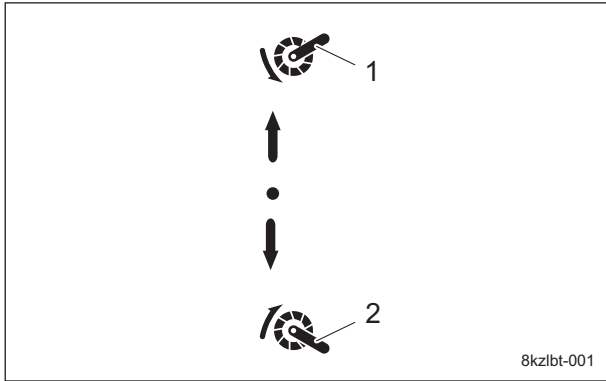

Mower Unit Up/Down Decal\_001

1	Down
2	Up

## Tilt Steering Decal

K4203001710  
Decal, tilt steering  
This illustrates the tilt directions of the steering wheel and the locked/free positions.

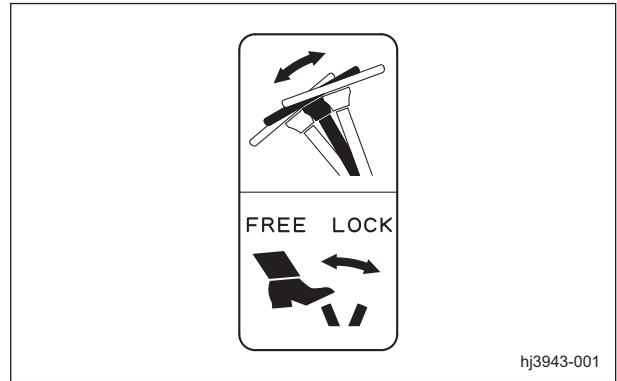

Tilt Steering Decal\_001

## Parking Brake Decal

K4203001700  
Decal, parking brake  
This shows how to lock and release the parking brake.

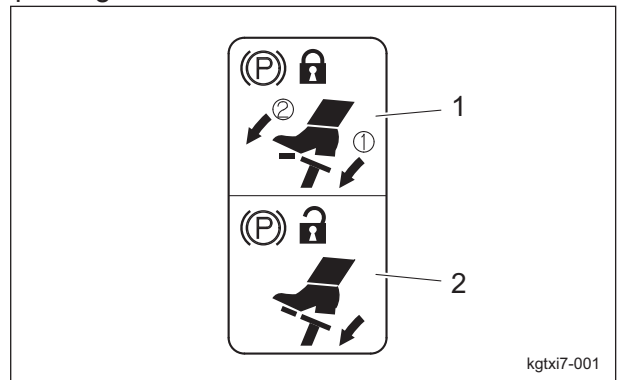

Parking Brake Decal\_001

1	Lock
2	Release

## Traveling/Working Selector Mark

Traveling/working selector mark  
It illustrates the positions where mower units #4 and #5 stop when they are raised. (ON/OFF of slight lift function)

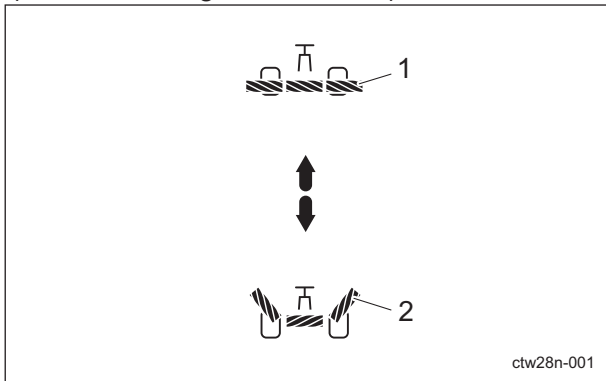

Traveling/Working Selector Mark\_001

1	Working
2	Traveling

# Handling Instructions

## BRAKE Decal

K4203001450  
Decal, BRAKE  
This indicates brake.



BRAKE Decal\_001

## Driving Mode Shift Decal

K4203001740  
Decal, shifting driving mode  
This indicates high/low speed.

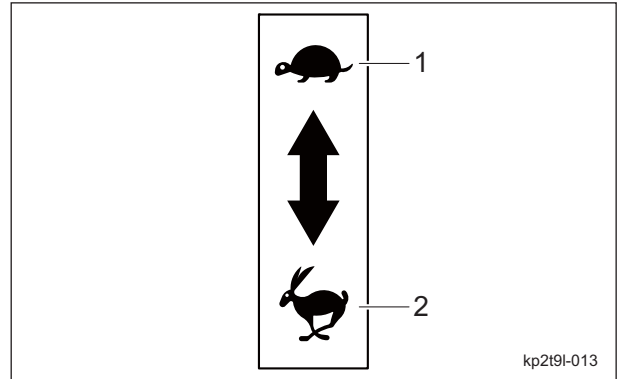

Driving Mode Shift Decal\_001

1	Working speed
2	Traveling speed

## FORWARD Decal

K4203001430  
Decal, FORWARD  
This indicates forward travel.



FORWARD Decal\_001

## Lever Open/Close Decal

K4203001720  
Decal, open/close lever  
This indicates lock/release of open/close lever.

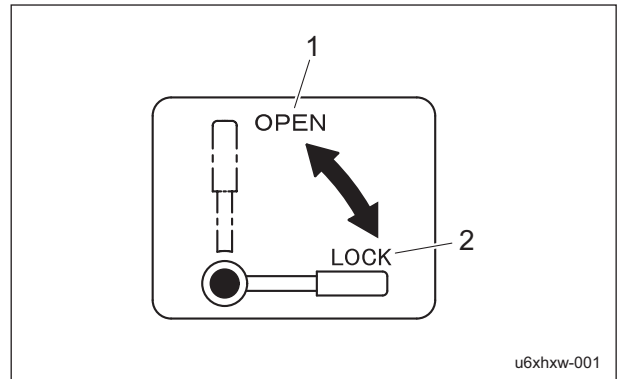

Lever Open/Close Decal\_001

1	Release
2	Lock

## BACKWARD Decal

K4203001440  
Decal, BACKWARD  
This indicates backward travel.



BACKWARD Decal\_001

# Handling Instructions

## Lapping Decal

K4203001590

Decal, lapping

This indicates rotational direction of the reel cutter (cutting cylinder).

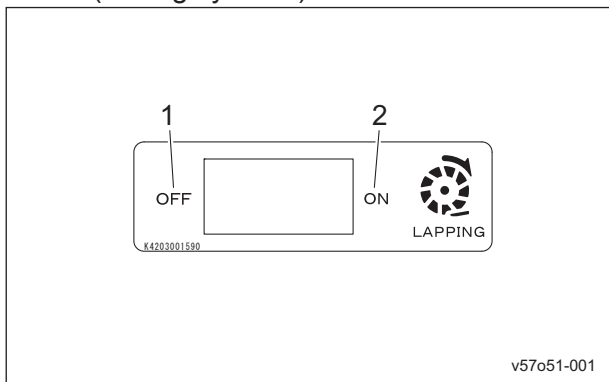

Lapping Decal\_001

1	Normal rotation (cutting rotation)
2	Reverse rotation (back lapping rotation)

## Reel Rotation Decal

K4203001300

Decal, reel rotation

This indicates rotation of the reel cutter (cutting cylinder).

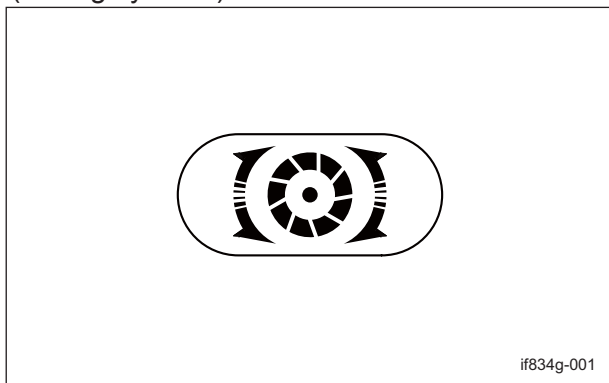

Reel Rotation Decal\_001

## Reel Stop Decal

K4203001310

Decal, reel stop

This indicates stop of the reel cutter (cutting cylinder).

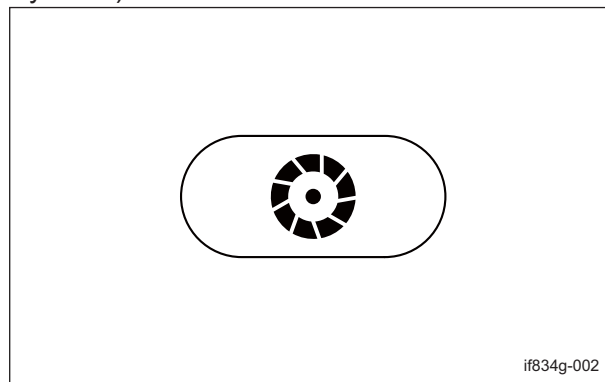

Reel Stop Decal\_001

## DPF Switch Decal

LM551--0586Z0

Decal, DPF Switch

This indicates the changeover of DPF regeneration.

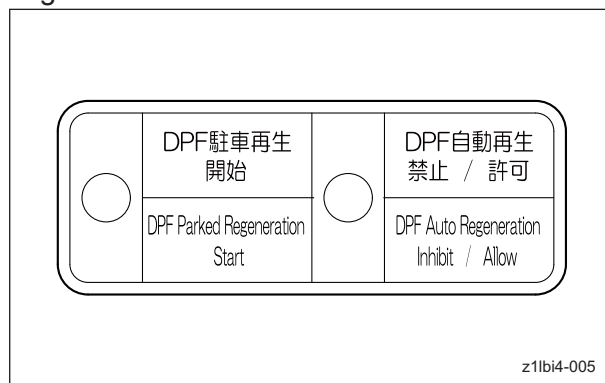

DPF Switch Decal\_001

# Handling Instructions

## Proximity Sensor

There are four proximity sensors on #1, #2, #4 and #5 mower arm fulcrums. These sensors detect the raised or lowered positions of mower units #1, #2, #4 and #5. The information is related to controlling rotation and stop of the reel cutter (cutting cylinder).

- Mower unit #1

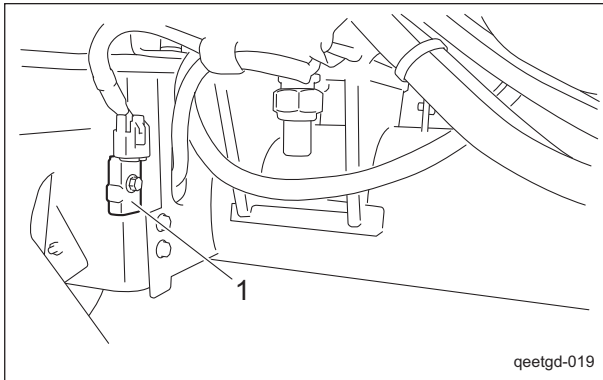

Proximity Sensor\_001

1	Proximity sensor
---	------------------

- Mower unit #2

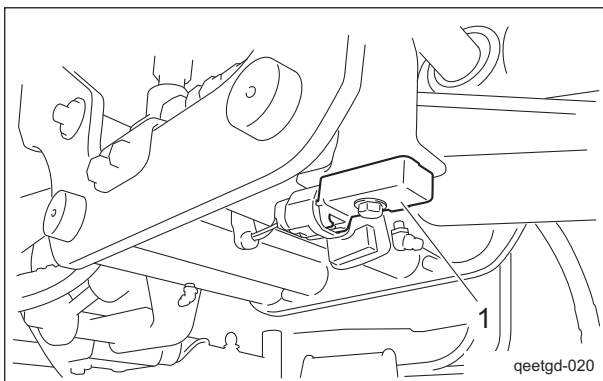

Proximity Sensor\_002

1	Proximity sensor
---	------------------

- Mower units #4 and #5

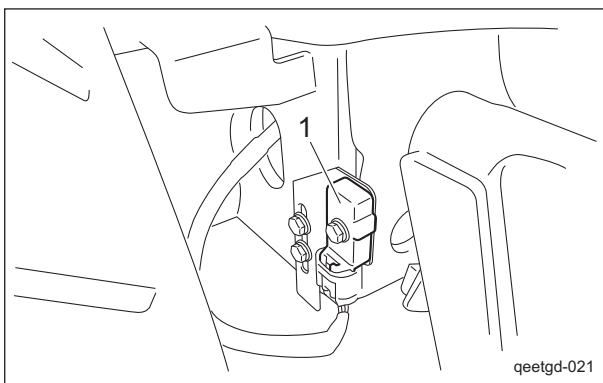

Proximity Sensor\_003

1	Proximity sensor
---	------------------

## Relays

The relay box is located inside the underseat cover.

These relays control traveling/working selection, rotation of the reel cutters (cutting cylinders), and mower unit lowering selection. The operating condition can be checked by the illumination of the LEDs.

- LEDs ① and ② light up when the traveling/working selector switch is in the "Working" position and mower units #4 and #5 are raised.
- LED ③ lights up when the parking brake is applied.
- LED ④ lights up when the mower unit up/down lever is in the "Down" position and the traveling/working selector switch is in the "Working" position.
- LEDs ⑤ and ⑥ light up when the reel rotation switch is in the "ON" position and the mower units are lowered.
- LEDs ⑦ and ⑧ light up when the reel reverse switch is in the "ON" position.

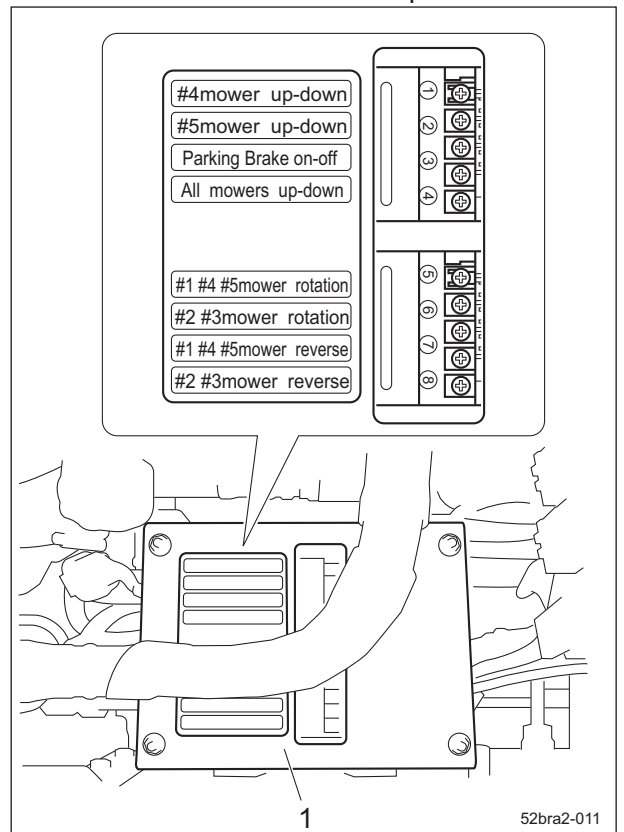

Relays\_001

1	Relay box
---	-----------

# Handling Instructions

## Light Switch

Note:  
Depending on the specifications, this function may not be available.

**Caution**

The lights provide auxiliary lighting. Do not travel or operate the machine at night or under poor visibility.

The light switch is located in the operation panel. When the switch is set to the "Turn on" position, the lights turn on. When it is set to the "Turn off" position, the lights turn off.

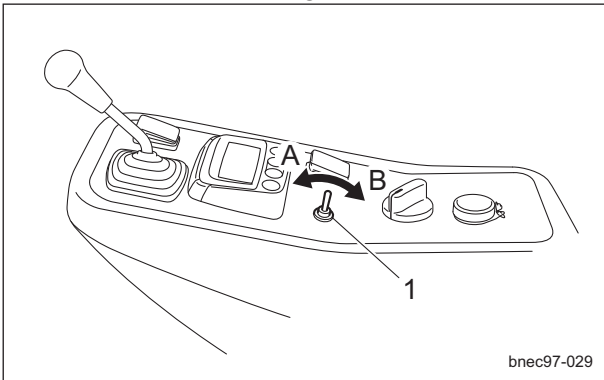

Light Switch\_001

1	Light switch
A	Turn on
B	Turn off

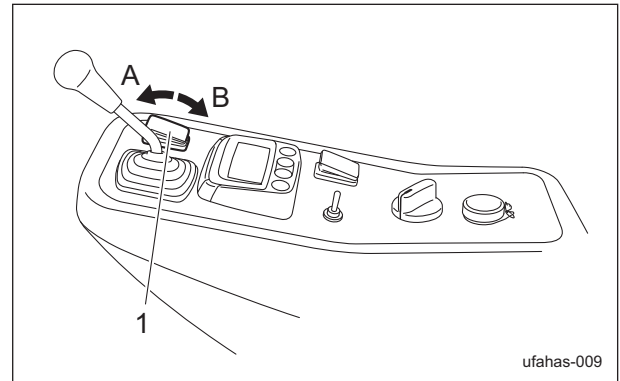

ufahas-009

Traveling/Working Selector Switch\_001

1	Traveling/working selector switch
A	Working
B	Traveling

When the switch is set to the "Traveling" position, mower units #4 and #5 are raised to their highest positions. When the switch is set to the "Working" position, mower units #4 and #5 are only raised halfway.

When set to the "Traveling" position

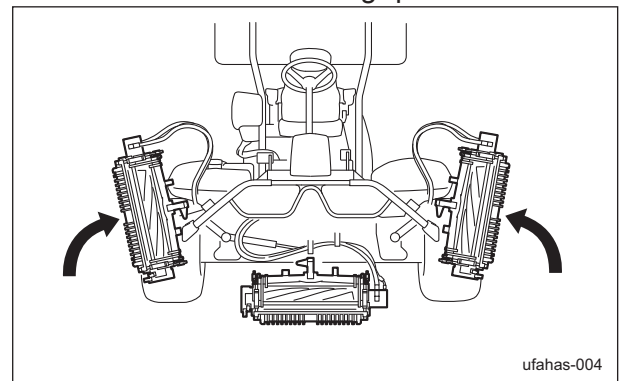

ufahas-004

Traveling/Working Selector Switch\_002

When set to the "Working" position

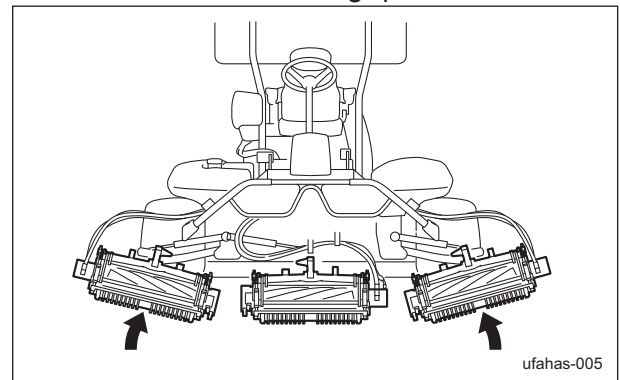

ufahas-005

Traveling/Working Selector Switch\_003

## Traveling/Working Selector Switch

**Important**

Set the traveling/working selector switch to the "Working" position before lowering the mower units. The mower units cannot be lowered with the switch set to the "Traveling" position.

The traveling/working selector switch is located in the operation panel. This can change the positions where mower units #4 and #5 stop when they are raised.

# Handling Instructions

## Reel Rotation Switch

**⚠ Caution**

Set the reel rotation switch to the "Rotation" position immediately before starting cutting work. At all other times, be sure to leave the reel rotation switch set to the "Stop" position.

The reel rotation switch is located in the operation panel and operates rotation of the reel cutters (cutting cylinders) of the mower units.

When the reel rotation switch is set to the "Rotation" position, the reel cutters (cutting cylinders) of all mower units will rotate for cutting work. When the reel rotation switch is set to the "Stop" position, the reel cutters (cutting cylinders) will stop.

**Note:**

When the mower units are raised, the reel cutters (cutting cylinders) do not rotate, even if the switch is set to the "Rotation" position.

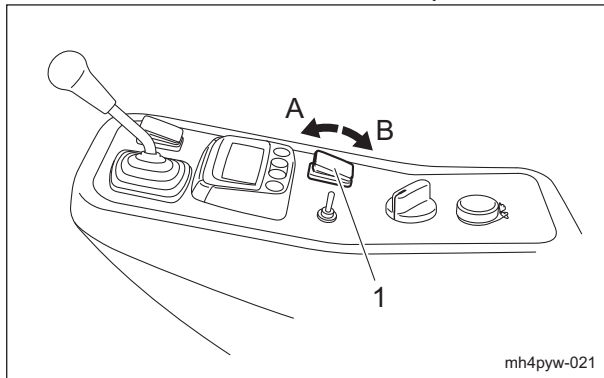

Reel Rotation Switch\_001

1	Reel rotation switch
A	Rotation
B	Stop

## Reel Forward/Reverse Switch

**Important**

Do not switch between "Forward" and "Reverse" while the reel cutter (cutting cylinder) is rotating. Otherwise, the hydraulic system will malfunction.

**Important**

If the reel rotation switch is not set to the "Rotation" position, the reel cutter (cutting cylinder) will not rotate.

The reel forward/reverse switch is located inside the underseat cover and switches the rotation direction of the reel cutters (cutting cylinders).

When the reel forward/reverse switch is set to the "Forward" position, the reel cutters (cutting cylinders) of all mower units will rotate for cutting work. When the reel forward/reverse switch is set to the "Reverse" position, the reel cutters (cutting cylinders) will rotate in reverse (back lapping rotation).

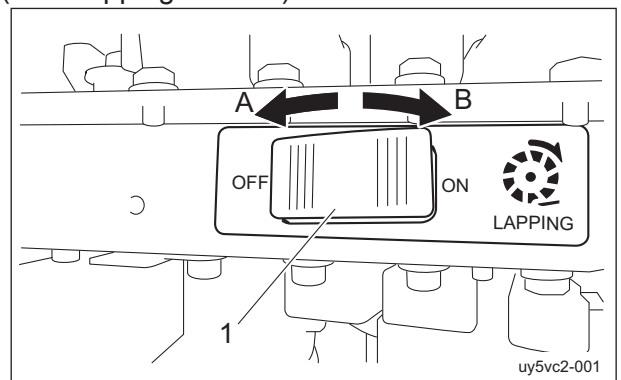

Reel Forward/Reverse Switch\_001

1	Reel forward/reverse switch
A	Forward
B	Reverse

# Handling Instructions

## Reel Rotation/Stop Switching Lever

**Caution**

Before operating the reel rotation/stop switching lever, be sure to set the reel rotation switch to the "Stop" position.

The reel rotation/stop switching lever is located on the reel motor attached to each mower unit. It is used during cutting and back lapping. Shift the lever(s) to the "Rotation" position only for the mower unit(s) to be used for cutting or back lapping. Leave the lever(s) for other mower units in the "Stop" position.

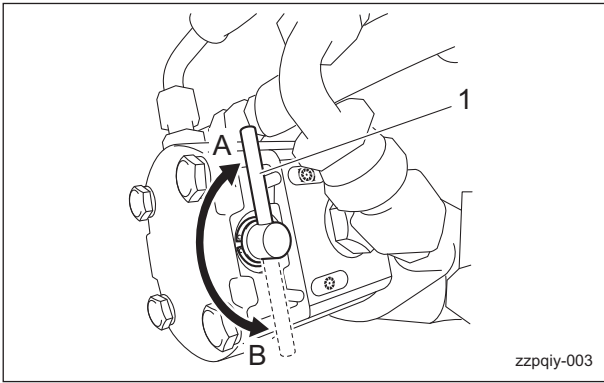

Reel Rotation/Stop Switching Lever\_001

1	Reel rotation/stop switching lever
A	Rotation
B	Stop

## Mower Lock Lever (Latch)

The mower lock levers (latches) are located in the foot area on the left and right sides and are used when traveling or storing the machine with mower units #4 and #5 raised.

When traveling or storing this machine, hook the mower lock levers (latches) on the arms.

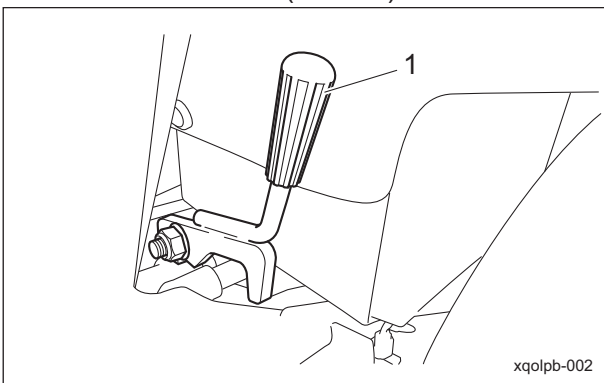

Mower Lock Lever (Latch)\_001

1	Mower Lock Lever (Latch)
---	--------------------------

## Mower Unit Up/Down Lever

**Caution**

Before raising or lowering the mower units, make sure that there are no people around the machine.

**Caution**

Be careful of the mower units lowering when the mower unit up/down lever is shifted to the "Down" position and the key switch is turned to the "ON" position while the engine is stopped with the traveling/working selector switch set to the "Working" position.

**Important**

When the mower lock levers (latches) are engaged, do not operate the mower unit up/down lever.

The mower unit up/down lever is located in the operation panel and raises or lowers the mower units.

When the lever is shifted to the "Down" position, the mower units are lowered. When the lever is shifted to the "Up" position, the mower units are raised.

When the lever is shifted to the "UP" position and then released from the hand, the lever returns to the neutral position.

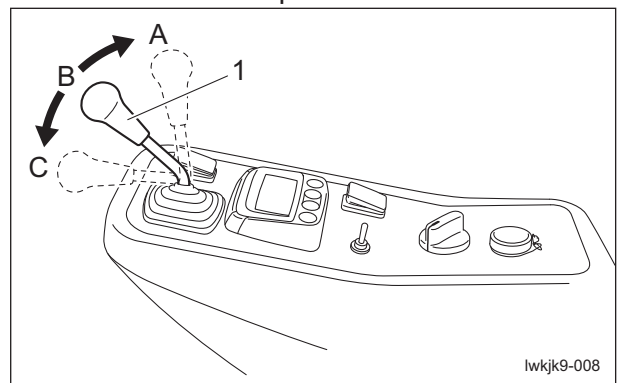

Mower Unit Up/Down Lever\_001

1	Mower unit up/down lever
A	Up
B	Neutral
C	Down



# Handling Instructions

**Note:**

When the mower units are raised, the reel cutters (cutting cylinders) stop rotating even if the reel rotation switch is set to the "Rotation" position.

## Throttle Knob

The throttle knob is located in the operation panel and enables you to adjust the engine rpm.

Move the throttle knob toward the "High speed" position to increase the engine rpm, and toward the "Low speed" position to reduce the rpm.

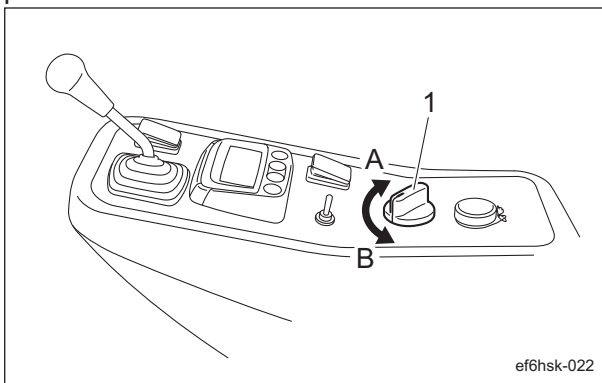

Throttle Knob\_001

1	Throttle knob
A	High speed
B	Low speed

## DPF Auto Regeneration Inhibit Switch

**Caution**

Normally, set the DPF auto regeneration inhibit switch to "Auto regeneration mode". However, when operating in a location where fires may occur, set the DPF auto regeneration inhibit switch to "Auto regeneration inhibit mode".

**Caution**

Do not use the switch during back lapping.

**Important**

The DPF auto regeneration inhibit switch is reset to "Auto regeneration mode" when the engine is started even if the engine was stopped with the DPF auto regeneration inhibit switch set to "Auto regeneration inhibit mode".

**Important**

In "Auto regeneration inhibit mode" any DPF regeneration of "Auto regeneration", "Parked regeneration" and "Manual regeneration" is inhibited.

For DPF regeneration, deactivate "Auto regeneration inhibit mode".

The DPF auto regeneration inhibit switch is located under the underseat cover. The DPF auto regeneration inhibit switch is the switch for shifting between "Auto regeneration mode" and "Auto regeneration inhibit mode". With the engine running, press this switch to shift between "Auto regeneration mode" and "Auto regeneration inhibit mode".

- **Auto regeneration mode:**  
The DPF auto regeneration inhibit switch is reset to "Auto regeneration mode" when the engine is started. In "Auto regeneration mode" DPF regeneration is automatically performed regardless of the main vehicle's travel and stop on the condition that a specific amount of PM is accumulated and the requirements for DPF regeneration are fulfilled.
- **Auto regeneration inhibit mode:**  
In order to set to "Auto regeneration inhibit mode", press the DPF auto regeneration inhibit switch after the engine is started. In "Auto regeneration inhibit mode" PM accumulates in the DPF and PM accumulation level increases. Unless the operator deactivates auto regeneration inhibit mode on his own will, regeneration is not performed.

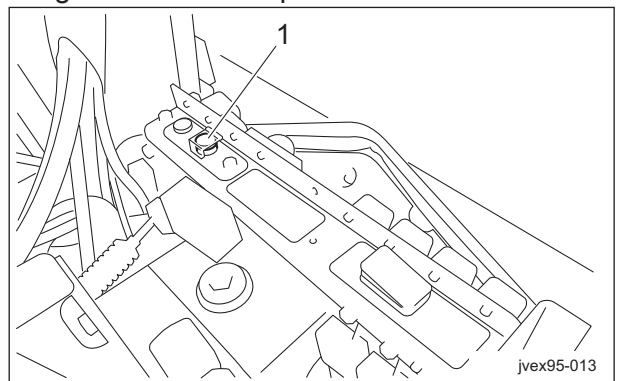

DPF Auto Regeneration Inhibit Switch\_001

1	DPF auto regeneration inhibit switch
---	--------------------------------------

# Handling Instructions

When the DPF auto regeneration inhibit switch is pressed and set to "Auto regeneration inhibit mode", the monitor displays Auto regeneration inhibit icon.

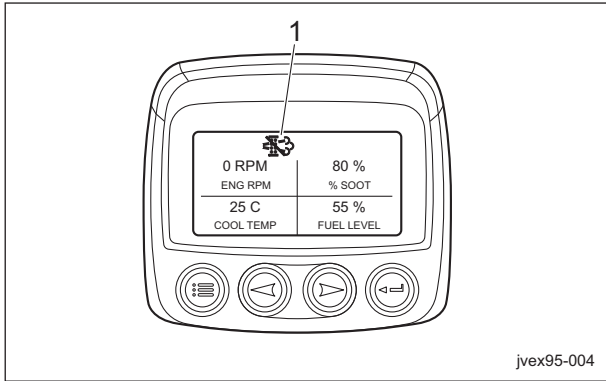

DPF Auto Regeneration Inhibit Switch\_002

1	Auto regeneration inhibit icon
---	--------------------------------

When parked regeneration starts, Regeneration icon in the monitor display changes from blinking to lighting.

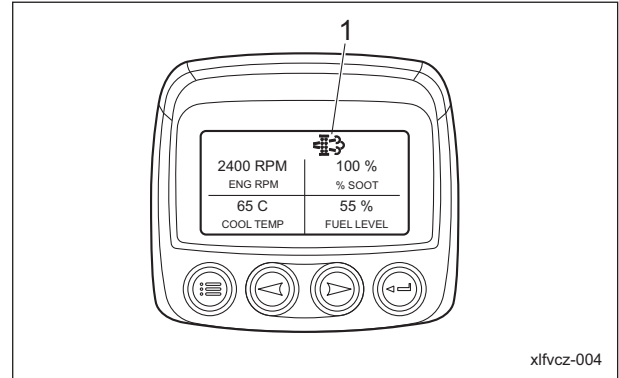

DPF Parked Regeneration Switch\_002

1	Regeneration icon
---	-------------------

## DPF Parked Regeneration Switch

### **⚠ Danger**

Do not perform DPF regeneration in a location where fires may occur since it will become extremely hot around the exhaust outlet during DPF regeneration.

### **⚠ Caution**

Do not use the switch during back lapping.

### **Important**

If parked regeneration is not required, it will not start even if the switch is pressed.

The DPF parked regeneration switch is located under the underseat cover.

The DPF parked regeneration switch is the switch for actuating parked regeneration. When the regeneration icon is blinking, press the switch to start parked regeneration.

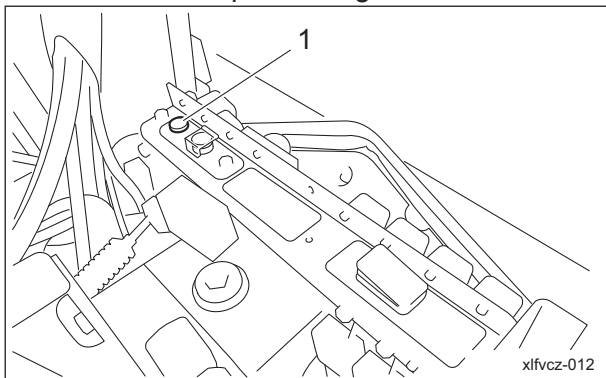

DPF Parked Regeneration Switch\_001

## Traveling Pedal

The traveling pedal is located in the right foot area.

When forward depressed, the machine travels forward. When backward depressed, the machine travels backward.

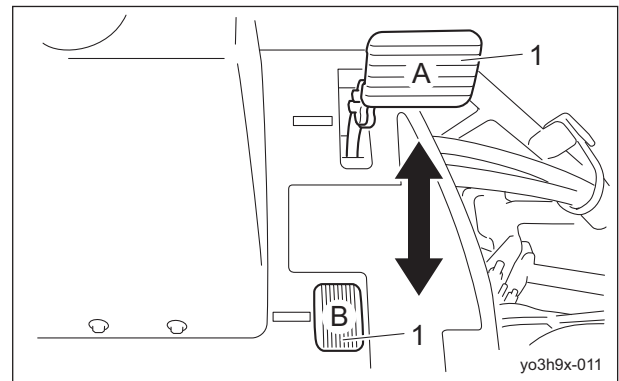

Traveling Pedal\_001

1	Traveling pedal
A	Forward
B	Backward

# Handling Instructions

The height and angle of the traveling pedal can be adjusted to fit the operator.

**Forward:**

The height and angle can be adjusted by changing the installation position of the bolt and spring washer.

**Backward:**

The height can be adjusted by changing the installation position of the bolt and spring washer.

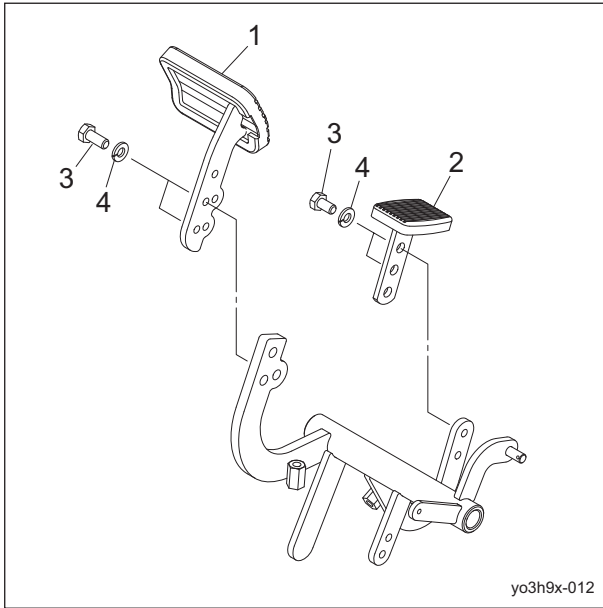

Traveling Pedal\_002

1	Traveling pedal (forward)
2	Traveling pedal (backward)
3	Bolt
4	Spring washer

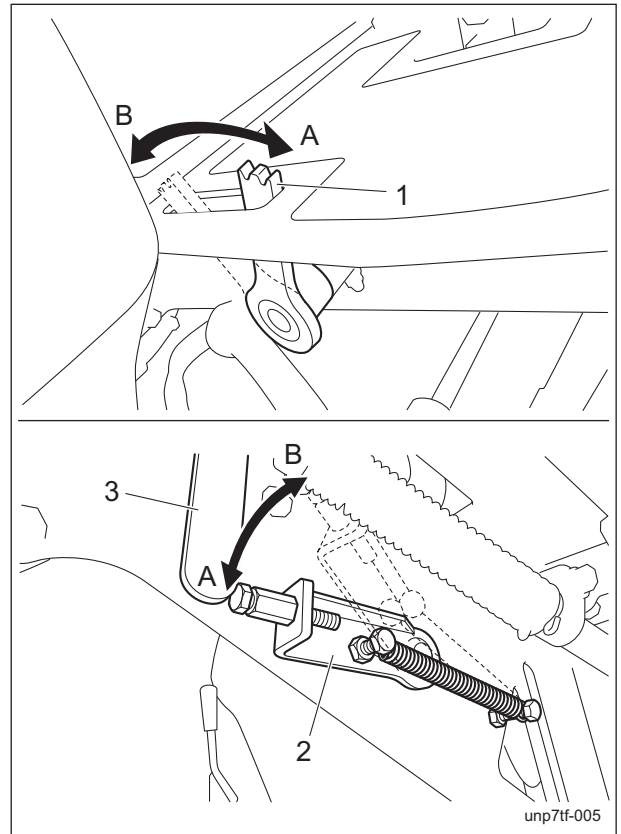

Pedal Stopper\_001

1	Pedal stopper
2	Operating speed lock lever
3	Traveling pedal
A	Working
B	Traveling

## Pedal Stopper

**Important**

When the traveling speed exceeds 12.0 km/h during cutting operation, a buzzer will sound. If the operation continues, the engine and hydraulic equipments will be damaged.

The pedal stopper is located in the right foot area.

This lever changes the amount that the forward pedal can be depressed.

Be sure to set the pedal stopper to the "Working" position during operation. You can adjust the amount that the forward pedal can be depressed. Loosen the bolt to adjust to 12 km/h or less.

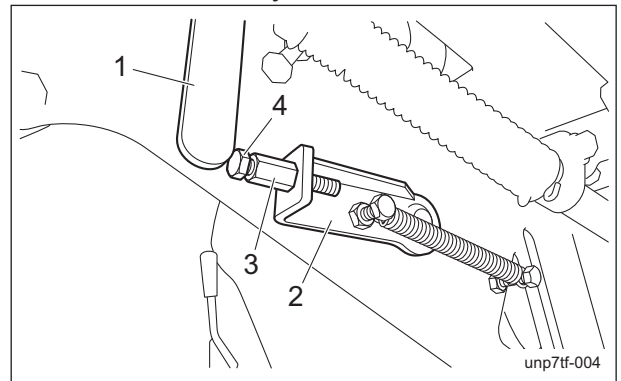

Pedal Stopper\_002

1	Traveling pedal
2	Operating speed lock lever
3	Lock nut
4	Bolt

# Handling Instructions

## Brake Pedal

**Caution**

When leaving the driver's seat, park the machine on a stable, flat surface and be sure to apply the parking brake.

**Caution**

Never park the machine on a slope.

The brake pedal is located in the left foot area. To stop the machine, firmly depress the brake pedal.

When parking, depress the locking pedal while firmly depressing the brake pedal to lock it.

To release the brake pedal, firmly depress the brake pedal to release the locking pedal.

Note:

Locking the brake pedal can be used as a parking brake.

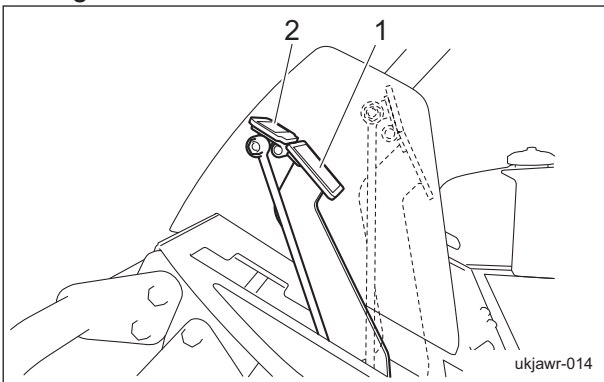

Brake Pedal\_001

1	Brake pedal
2	Locking pedal

## USB Socket

**Important**

Do not use the USB socket in rainy weather to avoid malfunction of devices.

Use the USB socket to charge or power USB devices such as a smartphone.

When the ignition key set to the "ON" position, it is energized and the blue indicator lights above the USB ports.

1. Set the ignition key to the "ON" position.

2. Open the protective cover.

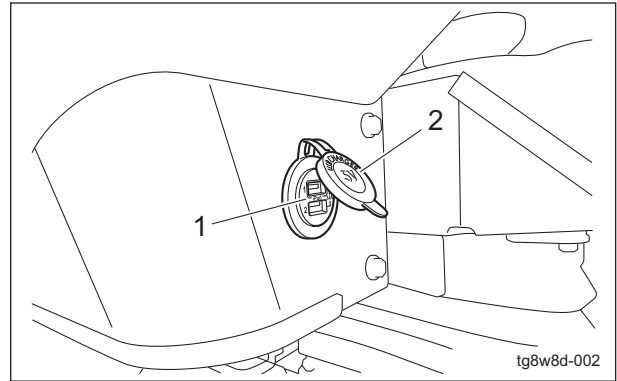

USB Socket\_001

1	USB port
2	Protective cover

3. Select a port according to the device connectivity.

The output power is DC5 V 3.4 A Max (2.4 A (Upper : iPad) +1 A (Lower)).

4. Insert the device USB plug into the port.

The blue indicator lights when applying current.

5. Close the protective cover after use.

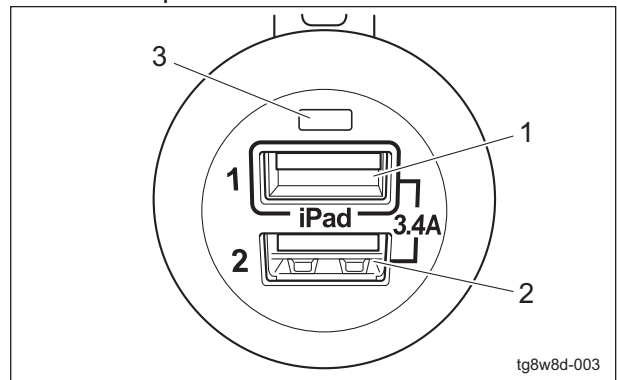

USB Socket\_002

1	2.4 A (iPad)
2	1 A
3	Indicator

# Handling Instructions

## Open-Close Lever

The open-close lever is located at the lower-left side of the seat.

This is used when opening and closing the underseat cover.

When opening the underseat cover, raise the open-close lever to unlock. After closing the underseat cover, lock it.

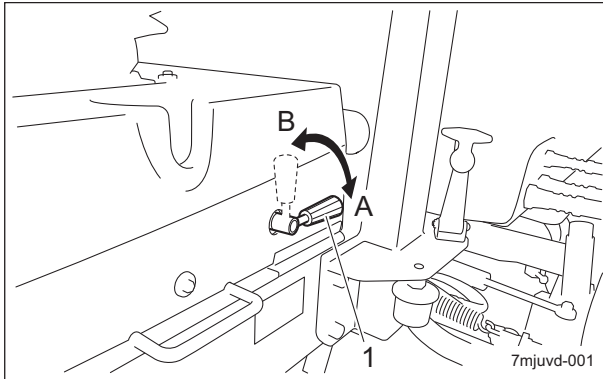

Open-Close Lever\_001

1	Open-close lever
A	Lock
B	Unlock

## Radiator Cover

**Caution**

Do not open the radiator cover in strong winds.

**Caution**

Be careful not to pinch your fingers when you open or close the cover.

1. Release the rubber catch.
2. Open the radiator cover to the right.

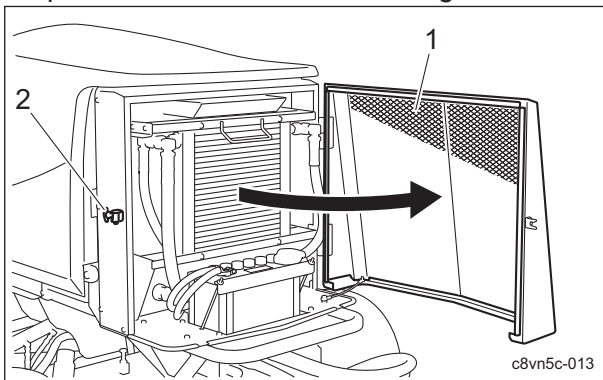

Radiator Cover\_001

1	Radiator cover
2	Rubber catch

3. Close the radiator cover slowly.
4. Lock the rubber catch securely.

## Hood

**Caution**

Do not open the hood in strong winds.

**Caution**

Be careful not to pinch your fingers when you open or close the hood.

1. Remove the nuts and bolts locking the catch clips on the left and right sides of the hood.

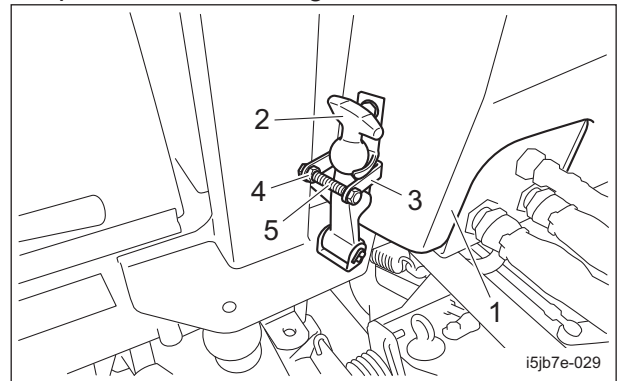

Hood\_001

1	Hood
2	Rubber catch
3	Catch clip
4	Nut
5	Bolt

2. Release the rubber catches on the left and right sides.

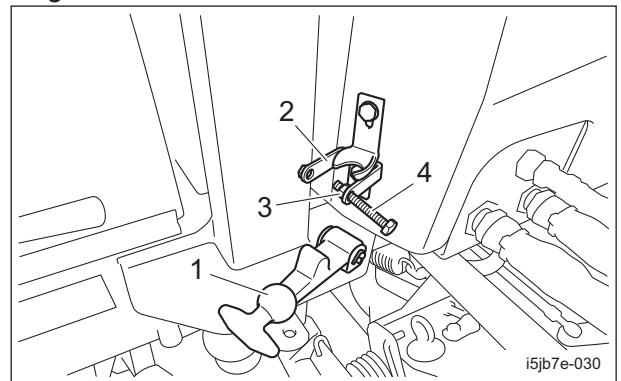

Hood\_002

# Handling Instructions

1	Rubber catch
2	Catch clip
3	Nut
4	Bolt

3. Make sure that the radiator cover is closed.
4. Lift up the hood.

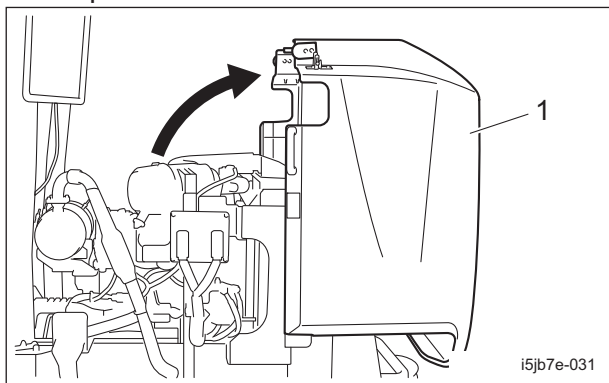

Hood\_003

1	Hood
---	------

5. Close the hood slowly.
6. Securely engage the left and right rubber catches.
7. Install the nuts and bolts locking the left and right catch clips.

## Underseat Cover

**Caution**

Be careful not to pinch your fingers when you open or close the cover.

1. Make sure that the steering wheel is raised completely.
2. Move the seat to the center between the forward and backward positions.
3. Tilt the seat backrest forward.

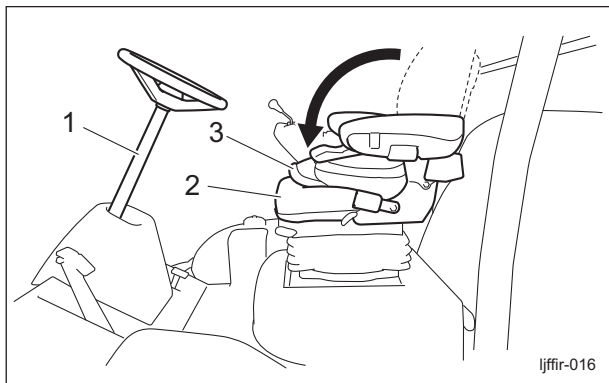

Underseat Cover\_001

1	Steering wheel
2	Seat
3	Backrest

4. While unlocking with the open-close lever, grab the grip and tilt the seat to the right to open the underseat cover.

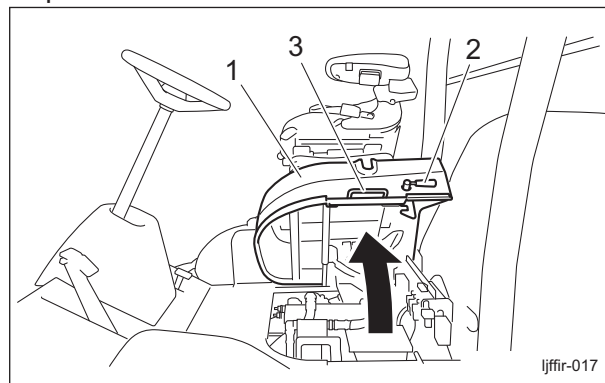

Underseat Cover\_002

1	Underseat cover
2	Open-close lever
3	Grip

## Step Cover

1. Remove the button head bolts.
2. Remove the step cover.

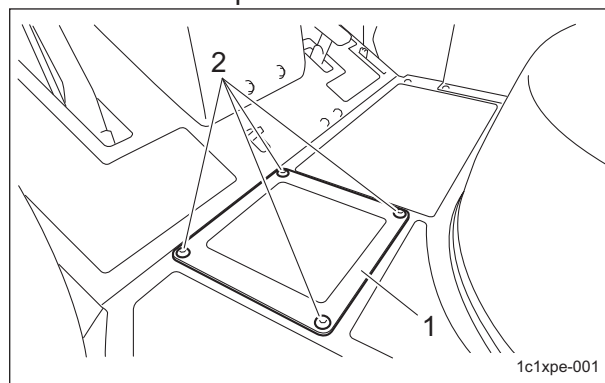

Step Cover\_001

1	Step cover
2	Button head bolt

For installation, reverse the removing procedure.

## Instruments

### Description of Monitor

The monitor displays various information about the machine, such as the operating status and fault conditions.

The information of desired items can be confirmed according to operating the keys.

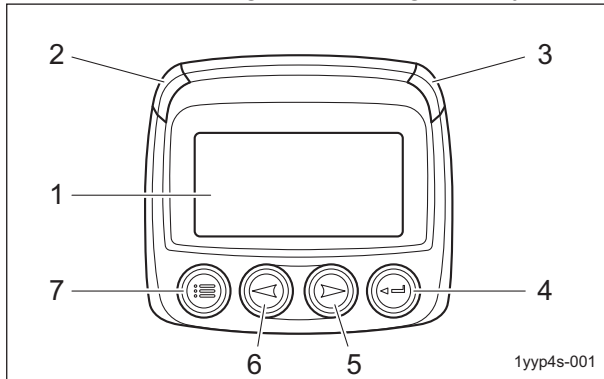

Description of Monitor\_001

1	Monitor display
2	LED (yellow)
3	LED (red)
4	Enter key
5	Right arrow key
6	Left arrow key
7	Menu key

1. Monitor display  
Displays machine conditions and items.
2. LED (yellow)  
Lights up when a malfunction is detected, indicating warning and/or caution on the engine.
3. LED (red)  
Lights up when a critical malfunction on the engine is detected.
4. Enter key  
Selects the menu or parameter.  
Switches between displaying/hiding the current fault code.
5. Right arrow key  
Scrolls the screen.  
Move the parameter selection to the right or down.
6. Left arrow key  
Scrolls the screen.  
Move the parameter selection to the left or up.
7. Menu key  
Opens or exits the menu.

### Displayed Icon

The icon appears at the top of the monitor display.

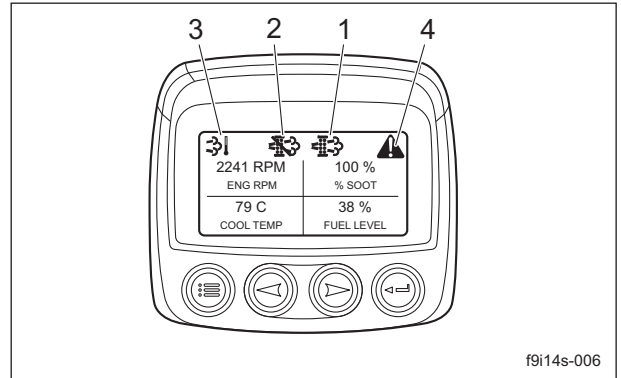

Displayed Icon\_001

1	Regeneration icon
2	Auto regeneration inhibit icon
3	High exhaust temperature icon
4	Warning mark

1. Regeneration icon  
The regeneration icon appears with DPF regeneration request or during DPF regeneration.
  - DPF regeneration request: Blinking
  - During DPF regeneration: Lighting
2. Auto regeneration inhibit icon  
The auto regeneration inhibit icon lights up when the DPF auto regeneration inhibit switch is set to the "Auto regeneration inhibit mode".
3. High exhaust temperature icon  
The high exhaust temperature icon lights up when the exhaust temperature reaches 450 °C during DPF regeneration.
4. Warning mark  
The warning mark continues to be displayed in the upper right corner of the monitor display if the warning message ignored and the Enter key pressed to hide the message.
  - Service reminders
  - Low fuel level
  - Fault codes

# Handling Instructions

## Main Menu Items

While any parameter is displayed, press the menu key to display the main menu with the following 11 items.

- GO TO 1-UP DISPLAY / GO TO 4-UP DISPLAY
- LANGUAGES
- STORED CODES
- ENGINE CONFIGURATION
- SETUP 1-UP DISPLAY
- SETUP 4-UP DISPLAY
- SERVICE REMINDERS
- SELECT UNITS
- ADJUST BACKLIGHT
- ADJUST CONTRAST
- UTILITIES

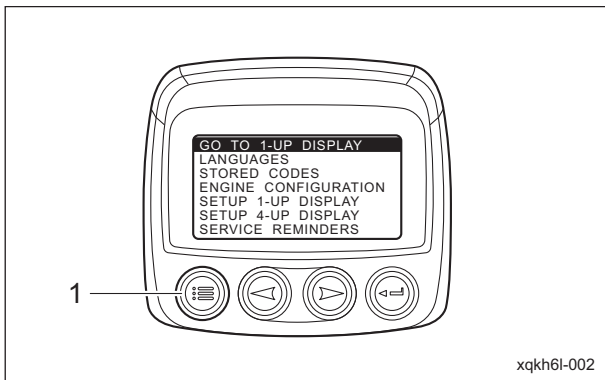

Main Menu Items\_001

1	Menu key
---	----------

## 1-Up Display / 4-Up Display

"GO TO 1-UP DISPLAY" / "GO TO 4-UP DISPLAY" are used to set whether to display parameters individually in a screen or in groups of four per screen.

### 1. 1-up display

One parameter is displayed individually in the monitor display.

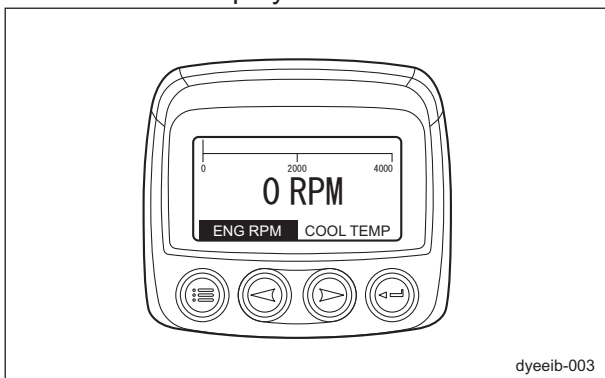

1-Up Display / 4-Up Display\_001

### 2. 4-up display

Four parameters are displayed in the monitor display.

With the 4-up display, a total of 8 parameters are displayed over 2 pages.

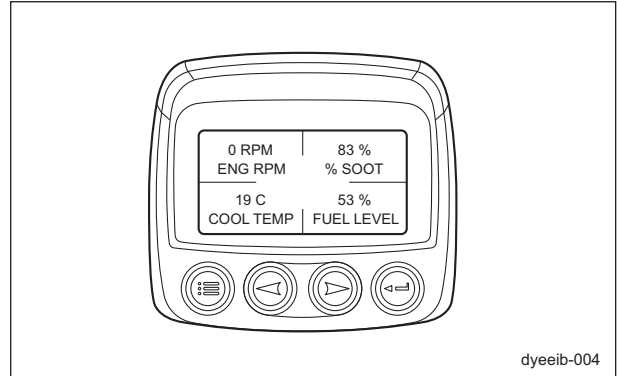

1-Up Display / 4-Up Display\_002

### Note:

The factory default display is the 4-up display. "GO TO 1-UP DISPLAY" appears in the main menu.

When the 1-up display is set, "GO TO 4-UP DISPLAY" appears in the main menu.



# Handling Instructions

## ■Parameter Items

(#30001-30047)

The parameters and corresponding information that appear in the monitor display are listed below.

No.	Monitor display L	Monitor display S	Description
1	ASH TIMER	ASH T	This parameter is not used.
2	ENGINE SPEED	ENG RPM	Displays the engine rpm.
3	DRIVERS DEMAND ENGINE TORQUE	DEMAND TQ	Displays the torque required by the ECU.
4	ACTUAL ENGINE TORQUE	ENG TORQ	Displays the actual torque.
5	PERCENT LOAD AT CURRENT RPM	LOAD@RPM	Displays the engine load factor.
6	ACCELERATOR PEDAL POSITION 1	ACCEL PED1	Displays the accelerator sensor opening.
7	ENGINE DESIRED OP SPEED	DES ENG SP	Displays the engine rpm required by the ECU.
8	ENGINE COOLANT TEMPERATURE	COOL TEMP	Displays the temperature measured by the coolant temperature sensor.
9	FUEL RATE	FUEL RATE	Displays the engine fuel consumption rate.
10	THROTTLE POSITION	THROTTLE	Displays the engine throttle opening.
11	BOOST PRESSURE	BST PRES	Displays the pressure measured by the intake pressure sensor.
12	INTAKE MANIFOLD TEMPERATURE	MANI TEMP	Displays the temperature measured by the intake temperature sensor built into the air flow sensor.
13	BATTERY POTENTIAL	BAT VOLT	Displays the battery voltage.
14	BAROMETRIC PRESSURE	BARO PRES	Displays the atmospheric pressure measured by the atmospheric pressure sensor.
15	AMBIENT AIR TEMP	AMB TEMP	Displays the ambient temperature.
16	AIR INLET TEMPERATURE	AIR IN TP	Displays the intake air temperature measured by the air flow sensor.
17	TOTAL FUEL USED	FUEL USED	Displays the total fuel consumption of the engine.
18	TOTAL ENGINE HOURS	ENG HRS	Displays the total time that the ECU is on (time that the key is in the "ON" position).
19	ENGINE OIL PRESSURE	OIL PRES	Displays the engine oil pressure measured by the oil pressure switch. While the engine is running: Normal=200 kPa, Abnormal=0 kPa
20	INJECTOR METERRING RAIL PRESS	RAIL PRES	Displays the fuel pressure in the rail, measured by the rail pressure sensor.
21	ENGINE INLET AIR MASS FLOW RATE	AIR RATE	Displays the intake air volume measured by the air flow sensor.
22	DOC INTAKE GAS TEMP	DOC TEMP	Displays the DOC inlet gas temperature measured by the exhaust temperature sensor.
23	EXHAUST FILTER INLET TEMP	EF IN T	Displays the DPF inlet gas temperature measured by the exhaust temperature sensor.

# Handling Instructions

---

No.	Monitor display L	Monitor display S	Description
24	DPF DIFFERENCE PRESSURE	DIFF PRES	Displays the pressure difference before and after the DPF, measured by the differential pressure sensor.
25	EXHAUST FILTER OUTLET TEMP	EF OUT T	Displays the DPF outlet gas temperature measured by the exhaust temperature sensor.
26	PARTICULATE TRAP LAMP	PT LAMP	Shows the status of the regeneration icon. Icon not displayed="OFF", Icon blinking="ON BLINK", Icon solid="ON SOLID"
27	DPF STATUS	DPF ST	Shows the status of the DPF. DPF regeneration not needed="REGEN NOT NEEDED" DPF regeneration needed=(Level 1="NEEDED LOWEST", Level 2-3="NEEDED MODERATE", Level 4="NEEDED HIGHEST")
28	DPF ACTIVE REGEN STATUS	DPF AR ST	Shows the DPF regeneration status. Regeneration not needed="INACTIVE", Regeneration needed="NEEDED", Regenerating="ACTIVE"
29	DPF REGEN INHIBIT STATUS	INHIBIT ST	Shows the ECU auto regeneration inhibited status. Auto regeneration inhibit switch off="OFF", Auto regeneration inhibit switch on="ON"
30	DPF REGENERATION INHIBITED SW	DPF INHIB SW	Shows the status of auto regeneration inhibit switch. Auto regeneration inhibit switch off="OFF", Auto regeneration inhibit switch on="ON"
31	EXHAUST HIGH TEMP LAMP	EXH T LAMP	Displays the condition of the exhaust temperature. 450 °C or more="ON", 450 °C or less="OFF"
32	%SOOT	%SOOT	Displays the amount of soot accumulated in the DPF.
33	MACHINE HOURS	MACH HRS	Displays the total operating time of the machine (time that the engine was actually running).
34	FUEL LEVEL	FUEL LEVEL	Displays the quantity of fuel remaining in the fuel tank.

**Note:**

When display settings are being specified, the parameters appear on "Monitor display L".  
At all other times, the parameters appear on "Monitor display S".

# Handling Instructions

## ■Parameter Items

(#30048-)

The parameters and corresponding information that appear in the monitor display are listed below.

No.	Monitor display L	Monitor display S	Description
1	ENGINE SPEED	ENG RPM	Displays the engine rpm.
2	DRIVERS DEMAND ENGINE TORQUE	DEMAND TQ	Displays the torque required by the ECU.
3	ACTUAL ENGINE TORQUE	ENG TORQ	Displays the actual torque.
4	PERCENT LOAD AT CURRENT RPM	LOAD@RPM	Displays the engine load factor.
5	ACCELERATOR PEDAL POSITION 1	ACCEL PED1	Displays the accelerator sensor opening.
6	ENGINE DESIRED OP SPEED	DES ENG SP	Displays the engine rpm required by the ECU.
7	ENGINE COOLANT TEMPERATURE	COOL TEMP	Displays the temperature measured by the coolant temperature sensor.
8	FUEL RATE	FUEL RATE	Displays the engine fuel consumption rate.
9	THROTTLE POSITION	THROTTLE	Displays the engine throttle opening.
10	BOOST PRESSURE	BST PRES	Displays the pressure measured by the intake pressure sensor.
11	INTAKE MANIFOLD TEMPERATURE	MANI TEMP	Displays the temperature measured by the intake temperature sensor built into the air flow sensor.
12	BATTERY POTENTIAL	BAT VOLT	Displays the battery voltage.
13	BAROMETRIC PRESSURE	BARO PRES	Displays the atmospheric pressure measured by the atmospheric pressure sensor.
14	AMBIENT AIR TEMP	AMB TEMP	Displays the ambient temperature.
15	AIR INLET TEMPERATURE	AIR IN TP	Displays the intake air temperature measured by the air flow sensor.
16	TOTAL FUEL USED	FUEL USED	Displays the total fuel consumption of the engine.
17	TOTAL ENGINE HOURS	ENG HRS	Displays the total time that the ECU is on (time that the key is in the "ON" position).
18	ENGINE OIL PRESSURE	OIL PRES	Displays the engine oil pressure measured by the oil pressure switch. While the engine is running: Normal=200 kPa, Abnormal=0 kPa
19	INJECTOR METERRING RAIL PRESS	RAIL PRES	Displays the fuel pressure in the rail, measured by the rail pressure sensor.
20	ENGINE INLET AIR MASS FLOW RATE	AIR RATE	Displays the intake air volume measured by the air flow sensor.
21	DOC INTAKE GAS TEMP	DOC TEMP	Displays the DOC inlet gas temperature measured by the exhaust temperature sensor.
22	EXHAUST FILTER INLET TEMP	EF IN T	Displays the DPF inlet gas temperature measured by the exhaust temperature sensor.
23	DPF DIFFERENCE PRESSURE	DIFF PRES	Displays the pressure difference before and after the DPF, measured by the differential pressure sensor.

# Handling Instructions

---

No.	Monitor display L	Monitor display S	Description
24	EXHAUST FILTER OUTLET TEMP	EF OUT T	Displays the DPF outlet gas temperature measured by the exhaust temperature sensor.
25	PARTICULATE TRAP LAMP	PT LAMP	Shows the status of the regeneration icon. Icon not displayed="OFF", Icon blinking="ON BLINK", Icon solid="ON SOLID"
26	DPF STATUS	DPF ST	Shows the status of the DPF. DPF regeneration not needed="REGEN NOT NEEDED" DPF regeneration needed=(Level 1="NEEDED LOWEST", Level 2-3="NEEDED MODERATE", Level 4="NEEDED HIGHEST")
27	DPF ACTIVE REGEN STATUS	DPF AR ST	Shows the DPF regeneration status. Regeneration not needed="INACTIVE", Regeneration needed="NEEDED", Regenerating="ACTIVE"
28	DPF REGEN INHIBIT STATUS	INHIBIT ST	Shows the ECU auto regeneration inhibited status. Auto regeneration inhibit switch off="OFF", Auto regeneration inhibit switch on="ON"
29	DPF REGENERATION INHIBITED SW	DPF INHIB SW	Shows the status of auto regeneration inhibit switch. Auto regeneration inhibit switch off="OFF", Auto regeneration inhibit switch on="ON"
30	EXHAUST HIGH TEMP LAMP	EXH T LAMP	Displays the condition of the exhaust temperature. 450 °C or more="ON", 450 °C or less="OFF"
31	%SOOT	%SOOT	Displays the amount of soot accumulated in the DPF.
32	MACHINE HOURS	MACH HRS	Displays the total operating time of the machine (time that the engine was actually running).
33	FUEL LEVEL	FUEL LEVEL	Displays the quantity of fuel remaining in the fuel tank.

**Note:**

When display settings are being specified, the parameters appear on "Monitor display L".  
At all other times, the parameters appear on "Monitor display S".

# Handling Instructions

## Language

With "LANGUAGES", the language used in the monitor display can be set to either of the following two.

- ENGLISH
- JAPANESE

An asterisk appears at the right of the currently selected language.

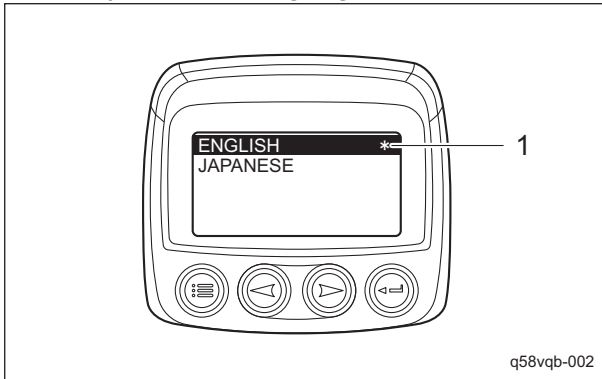

Language\_001

1	Asterisk
---	----------

**Note:**

The factory default language is "ENGLISH".

## Fault Code Log

With "STORED CODES", a log of past fault codes can be checked.

When there is a fault code log, each fault is displayed over two pages.

Use the arrow keys to change the page.

- Text 1

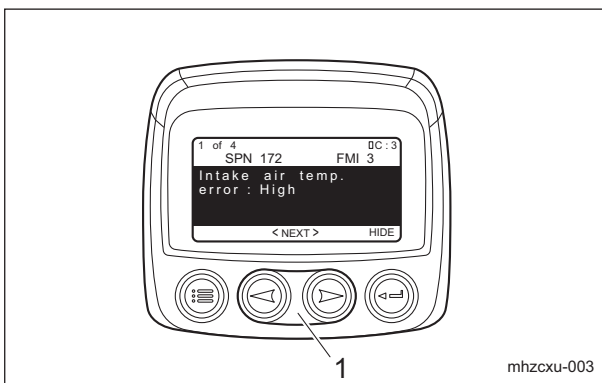

Fault Code Log\_001

1	Arrow keys
---	------------

- Text 2

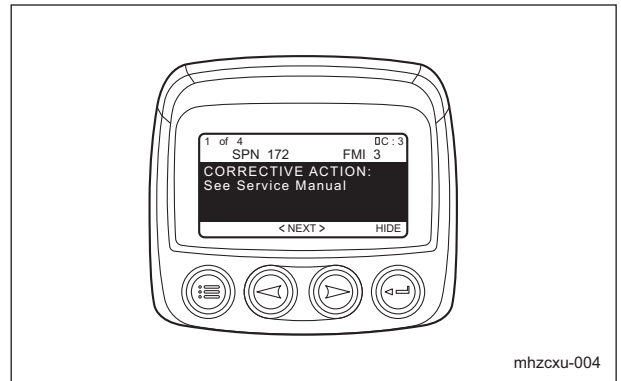

Fault Code Log\_002

If there is no fault code log, "NO STORED FAULT CODES" appears.

# Handling Instructions

## ■List of Fault Codes

(#30001-30047)

### Important

When the fault code appears in the monitor display, refer to "Kubota DIAGNOSIS MANUAL" or contact your dealer.

The fault codes (DTC) and corresponding information that appear in the monitor display are listed below.

DTC name Text 1	Corrective action Text 2	ISO 14229 P-Code	J1939-73		Detected item <DM>	Limp Home Action by engine ECU (System action) <DM>	Behaviour During Malfunction <DM>	Recovery from error <DM>
			SPN	FMI				
NE-G phase gap	See Service Manual	P0016	636	7	<ul style="list-style-type: none"> <li>Stuck at SCV valve open position (Actual rail pressure consistently higher than command rail pressure)</li> </ul>	<ul style="list-style-type: none"> <li>Output limit: Q value of approx. 50 % or less</li> <li>Accelerator limitation: 50 % or less</li> <li>Rail pressure restriction: Command pressure <math>\leq</math> 80 MPa (820 kgf/cm<sup>2</sup>, 12000 psi)</li> <li>EGR stops</li> </ul>	<ul style="list-style-type: none"> <li>Insufficient output</li> <li>Worsening exhaust gas performance</li> <li>Engine stops in some cases</li> </ul>	<ul style="list-style-type: none"> <li>Key switch OFF</li> </ul>
Intake air temperature sensor (built-in mass air flow sensor) low	See Service Manual	P0072	171	4	<ul style="list-style-type: none"> <li>Fuel leak from high pressure fuel system (Fuel consumption is calculated from the difference of fuel pressure of before and after the injection, and excess fuel consumption is found)</li> </ul>	<ul style="list-style-type: none"> <li>Output limit: Q value of approx. 50 % or less</li> <li>Accelerator limitation: 50 % or less</li> <li>Rail pressure restriction: Command pressure <math>\leq</math> 80 MPa (820 kgf/cm<sup>2</sup>, 12000 psi)</li> <li>EGR stops</li> </ul>	<ul style="list-style-type: none"> <li>Insufficient output</li> <li>Worsening exhaust gas performance</li> <li>Engine stops in some cases</li> </ul>	<ul style="list-style-type: none"> <li>Key switch OFF</li> </ul>
Intake air temperature sensor (built-in mass air flow sensor) high	See Service Manual	P0073	171	3	<ul style="list-style-type: none"> <li>Sensor/harness GND short circuit</li> </ul>	<ul style="list-style-type: none"> <li>[Default value] During start-up = -20 °C (-4 °F)</li> <li>[Default value] Other = 40 °C (104 °F)</li> </ul>	<ul style="list-style-type: none"> <li>increase in amount of white smoke at low temperature</li> </ul>	<ul style="list-style-type: none"> <li>Diagnostic counter = 0</li> </ul>

# Handling Instructions

DTC name Text 1	Corrective action Text 2	ISO 14229 P-Code	J1939-73		Detected item <DM>	Limp Home Action by engine ECU (System action) <DM>	Behaviour During Malfunction <DM>	Recovery from error <DM>
			SPN	FMI				
High rail pressure abnormality	See Service Manual	P0088	157	0	<ul style="list-style-type: none"> <li>• Sensor/harness disconnection or power supply short</li> </ul>	<ul style="list-style-type: none"> <li>• [Default value] During start-up = -20 °C (-4 °F)</li> <li>• [Default value] Other = 40 °C (104 °F)</li> </ul>	<ul style="list-style-type: none"> <li>• Increase in amount of white smoke at low temperature</li> </ul>	<ul style="list-style-type: none"> <li>• Diagnostic counter = 0</li> </ul>
SCV S tuck diagnosis	Stop ENG, See Service Manual	P0089	1347	7	<ul style="list-style-type: none"> <li>• Sensor/harness GND short circuit</li> </ul>	<ul style="list-style-type: none"> <li>• [Default value] During start-up = -25 °C (-13 °F)</li> <li>• [Default value] Other = 80 °C (176 °F)</li> <li>• Output limit: Q value of approx. 50 % or less</li> <li>• Accelerator limitation: 50 % or less</li> <li>• EGR stops</li> </ul>	<ul style="list-style-type: none"> <li>• Increase in amount of white smoke at low temperature</li> <li>• Insufficient output</li> <li>• Worsening exhaust gas performance</li> </ul>	<ul style="list-style-type: none"> <li>• Key switch OFF</li> </ul>
Fuel leak (high-pressure fuel system)	Stop ENG, See Service Manual	P0093	1239	1	<ul style="list-style-type: none"> <li>• Sensor/harness disconnection or power supplyshort</li> </ul>	<ul style="list-style-type: none"> <li>• [Default value] During start-up = -25 °C (-13 °F)</li> <li>• [Default value] Other = 80 °C (176 °F)</li> <li>• Output limit: Q value of approx. 50 % or less</li> <li>• Accelerator limitation: 50 % or less</li> <li>• EGR stops</li> </ul>	<ul style="list-style-type: none"> <li>• Increase in amount of white smoke at low temperature</li> <li>• Insufficient output</li> <li>• Worsening exhaust gas performance</li> </ul>	<ul style="list-style-type: none"> <li>• Key switch OFF</li> </ul>
Intake air shortage abnormality (suction hose disconnected from turbo blower)	See Service Manual	P0101	132	1	<ul style="list-style-type: none"> <li>• Sensor/harness GND short circuit</li> <li>• Failure of sensor</li> </ul>	<ul style="list-style-type: none"> <li>• Output limit: Q value of approx. 50 % or less</li> <li>• Accelerator limitation: 50 % or less</li> <li>• Rail pressure restriction: Command pressure ≤ 80 MPa (820</li> </ul>	<ul style="list-style-type: none"> <li>• Insufficient output</li> <li>• Worsening exhaust gas performance</li> <li>• Worsening running noise</li> <li>• Increase in white smoke</li> <li>• Engine stop</li> </ul>	<ul style="list-style-type: none"> <li>• Key switch OFF</li> </ul>

# Handling Instructions

DTC name Text 1	Corrective action Text 2	ISO 14229 P-Code	J1939-73		Detected item <DM>	Limp Home Action by engine ECU (System action) <DM>	Behaviour During Malfunction <DM>	Recovery from error <DM>
			SPN	FMI				
Intake air shortage abnormality (suction hose disconnected from turbo blower)	See Service Manual	P0101	132	1	<ul style="list-style-type: none"> <li>• Sensor/ harness GND short circuit</li> <li>• Failure of sensor</li> </ul>	kgf/cm <sup>2</sup> , 12000 psi) <ul style="list-style-type: none"> <li>• EGR stops</li> <li>• Engine forcibly stopped 60 sec later</li> </ul>	<ul style="list-style-type: none"> <li>• Insufficient output</li> <li>• Worsening exhaust gas performance</li> <li>• Worsening running noise</li> <li>• Increase in white smoke</li> <li>• Engine stop</li> </ul>	<ul style="list-style-type: none"> <li>• Key switch OFF</li> </ul>
Mass air flow (MAF) sensor: Low	See Service Manual	P0102	132	4	<ul style="list-style-type: none"> <li>• Sensor/ harness disconnection or power supply short</li> <li>• Failure of sensor</li> </ul>	<ul style="list-style-type: none"> <li>• Output limit: Q value of approx. 50 % or less</li> <li>• Accelerator limitation: 50 % or less</li> <li>• Rail pressure restriction: Command pressure ≤ 80 MPa (820 kgf/cm<sup>2</sup>, 12000 psi)</li> <li>• EGR stops</li> <li>• Engine forcibly stopped 60 sec later</li> </ul>	<ul style="list-style-type: none"> <li>• Insufficient output</li> <li>• Worsening exhaust gas performance</li> <li>• Worsening running noise</li> <li>• Increase in white smoke</li> <li>• Engine stop</li> </ul>	<ul style="list-style-type: none"> <li>• Key switch OFF</li> </ul>
Mass air flow (MAF) sensor : high	See Service Manual	P0103	132	3	<ul style="list-style-type: none"> <li>• Voltage of ECU injector actuation is excessively large</li> </ul>	<ul style="list-style-type: none"> <li>• Output limit: Q value of approx. 50 % or less</li> <li>• Accelerator limitation: 50 % or less</li> <li>• EGR stops</li> <li>• Engine forcibly stopped 60 sec later</li> </ul>	<ul style="list-style-type: none"> <li>• Insufficient output</li> <li>• Worsening exhaust gas performance</li> <li>• Engine stop</li> </ul>	<ul style="list-style-type: none"> <li>• Key switch OFF</li> </ul>
Intake air temperature sensor: Low	See Service Manual	P0112	172	4	<ul style="list-style-type: none"> <li>• Disconnection for engine No. 1 cylinder injector (TWV1) coil or harness</li> </ul>	<ul style="list-style-type: none"> <li>• Output limit: Q value of approx. 50 % or less</li> <li>• Accelerator limitation: 50 % or less</li> <li>• EGR stops</li> </ul>	<ul style="list-style-type: none"> <li>• Insufficient output</li> <li>• Increased vibration</li> <li>• Worsening exhaust gas performance</li> </ul>	<ul style="list-style-type: none"> <li>• Key switch OFF</li> </ul>



# Handling Instructions

DTC name Text 1	Corrective action Text 2	ISO 14229 P-Code	J1939-73		Detected item <DM>	Limp Home Action by engine ECU (System action) <DM>	Behaviour During Malfunction <DM>	Recovery from error <DM>
			SPN	FMI				
Intake air temperature sensor: High	See Service Manual	P0113	172	3	<ul style="list-style-type: none"> <li>Disconnection for engine No. 3 cylinder injector (TWV2) coil or harness</li> </ul>	<ul style="list-style-type: none"> <li>Output limit: Q value of approx. 50 % or less</li> <li>Accelerator limitation: 50 % or less</li> <li>EGR stops</li> </ul>	<ul style="list-style-type: none"> <li>Insufficient output</li> <li>Increased vibration</li> <li>Worsening exhaust gas performance</li> </ul>	<ul style="list-style-type: none"> <li>Key switch OFF</li> </ul>
Coolant temperature sensor: Low	See Service Manual	P0117	110	4	<ul style="list-style-type: none"> <li>Disconnection for engine No. 4 cylinder injector (TWV3) coil or harness</li> </ul>	<ul style="list-style-type: none"> <li>Output limit: Q value of approx. 50 % or less</li> <li>Accelerator limitation: 50 % or less</li> <li>EGR stops</li> </ul>	<ul style="list-style-type: none"> <li>Insufficient output</li> <li>Increased vibration</li> <li>Worsening exhaust gas performance</li> </ul>	<ul style="list-style-type: none"> <li>Key switch OFF</li> </ul>
Coolant temperature sensor: High	See Service Manual	P0118	110	3	<ul style="list-style-type: none"> <li>Disconnection for Engine No. 2 cylinder injector (TWV4) coil or harness</li> </ul>	<ul style="list-style-type: none"> <li>Output limit: Q value of approx. 50 % or less</li> <li>Accelerator limitation: 50 % or less</li> <li>EGR stops</li> </ul>	<ul style="list-style-type: none"> <li>Insufficient output</li> <li>Increased vibration</li> <li>Worsening exhaust gas performance</li> </ul>	<ul style="list-style-type: none"> <li>Key switch OFF</li> </ul>
Fuel high temperature	See Service Manual	P0181	174	0	<ul style="list-style-type: none"> <li>Abnormally high engine coolant temperature</li> </ul>	<ul style="list-style-type: none"> <li>Output limit: Torque of 75 % or less</li> <li>EGR stops</li> </ul>	<ul style="list-style-type: none"> <li>Insufficient output</li> <li>Overheating</li> </ul>	<ul style="list-style-type: none"> <li>Diagnostic counter = 0</li> </ul>
Fuel temperature sensor: Low	See Service Manual	P0182	174	4	<ul style="list-style-type: none"> <li>Engine speed exceeds threshold value</li> </ul>	<ul style="list-style-type: none"> <li>Injection stops (Q = 0 mm<sup>3</sup>/st)</li> </ul>	<ul style="list-style-type: none"> <li>Overrun</li> </ul>	<ul style="list-style-type: none"> <li>Diagnostic counter = 0</li> </ul>
Fuel temperature sensor: High	See Service Manual	P0183	174	3	<ul style="list-style-type: none"> <li>Sensor/harness disconnection or GND short</li> <li>Sensor malfunction</li> </ul>	<ul style="list-style-type: none"> <li>[Default value] 65 kPa (0.66 kgf/cm<sup>2</sup>, 9.4 psi)</li> </ul>	<ul style="list-style-type: none"> <li>Insufficient output</li> </ul>	<ul style="list-style-type: none"> <li>Key switch OFF</li> </ul>
Rail pressure sensor: Low	Stop ENG, See Service Manual	P0192	157	4	<ul style="list-style-type: none"> <li>Sensor/wiring harness power supply short</li> <li>Sensor malfunction</li> </ul>	<ul style="list-style-type: none"> <li>[Default value] 65 kPa (0.66 kgf/cm<sup>2</sup>, 9.4 psi)</li> </ul>	<ul style="list-style-type: none"> <li>Insufficient output</li> </ul>	<ul style="list-style-type: none"> <li>Key switch OFF</li> </ul>
Rail pressure sensor: High	Stop ENG, See Service Manual	P0193	157	3	<ul style="list-style-type: none"> <li>Sensor/harness disconnection or short</li> <li>Failure of sensor</li> </ul>	<ul style="list-style-type: none"> <li>Output limit: Q value of approx. 50 % or less</li> <li>Accelerator limitation: 50 % or less</li> </ul>	<ul style="list-style-type: none"> <li>Faulty starting</li> <li>Slight increase in vibration</li> <li>Insufficient output</li> </ul>	<ul style="list-style-type: none"> <li>Diagnostic counter = 0</li> </ul>

# Handling Instructions

DTC name Text 1	Corrective action Text 2	ISO 14229 P-Code	J1939-73		Detected item <DM>	Limp Home Action by engine ECU (System action) <DM>	Behaviour During Malfunction <DM>	Recovery from error <DM>
			SPN	FMI				
ECU Injector charge voltage: High	Stop ENG, See Service Manual	P0200	52353 5	0	<ul style="list-style-type: none"> <li>• Sensor/ harness disconnection or short</li> <li>• Failure of sensor</li> </ul>	<ul style="list-style-type: none"> <li>• Output limit: Q value of approx. 50 % or less</li> <li>• Accelerator limitation: 50 % or less</li> </ul>	<ul style="list-style-type: none"> <li>• Faulty starting</li> <li>• Slight increase in vibration</li> <li>• Insufficient output</li> </ul>	<ul style="list-style-type: none"> <li>• Diagnostic counter = 0</li> </ul>
Open circuit of harness/coil in 1st cylinder injector	See Service Manual	P0201	651	3	<ul style="list-style-type: none"> <li>• Sensor/ harness disconnection or short</li> <li>• Failure of sensor</li> </ul>	None	<ul style="list-style-type: none"> <li>• Sluggish on startup</li> </ul>	<ul style="list-style-type: none"> <li>• Diagnostic counter = 0</li> </ul>
Open circuit of harness/coil in 3rd cylinder injector	See Service Manual	P0202	653	3	<ul style="list-style-type: none"> <li>• Sensor/ harness disconnection or short</li> <li>• Failure of sensor</li> </ul>	None	<ul style="list-style-type: none"> <li>• Sluggish on startup</li> </ul>	<ul style="list-style-type: none"> <li>• Diagnostic counter = 0</li> </ul>
Open circuit of harness/coil in 4th cylinder injector	See Service Manual	P0203	654	3	<ul style="list-style-type: none"> <li>• Short circuit of intake air heater relay actuation circuit to power supply</li> </ul>	None	<ul style="list-style-type: none"> <li>• Faulty starting at low temperature</li> <li>• Increase of white smoke at low temperatures</li> </ul>	<ul style="list-style-type: none"> <li>• Key switch OFF</li> </ul>
Open circuit of harness/coil in 2nd cylinder injector	See Service Manual	P0204	652	3	<ul style="list-style-type: none"> <li>• Short circuit of intake air heater relay actuation circuit to GND</li> </ul>	None	<ul style="list-style-type: none"> <li>• Faulty starting at low temperature</li> <li>• Increase of white smoke at low temperatures</li> </ul>	<ul style="list-style-type: none"> <li>• Key switch OFF</li> </ul>
Engine overheat	Stop mowing!!	P0217	110	0	<ul style="list-style-type: none"> <li>• Oil pressure switch behavior</li> </ul>	<ul style="list-style-type: none"> <li>• Engine stop</li> </ul>	<ul style="list-style-type: none"> <li>• Engine stop</li> </ul>	<ul style="list-style-type: none"> <li>• Key switch OFF</li> </ul>

# Handling Instructions

DTC name Text 1	Corrective action Text 2	ISO 14229 P-Code	J1939-73		Detected item <DM>	Limp Home Action by engine ECU (System action) <DM>	Behaviour During Malfunction <DM>	Recovery from error <DM>
			SPN	FMI				
Engine overrun abnormality	See Service Manual	P0219	190	0	<ul style="list-style-type: none"> <li>• Disconnection, short, or damage of harness</li> <li>• Battery fault</li> </ul>	<ul style="list-style-type: none"> <li>• Output limit: Q value of approx. 50 % or less</li> <li>• Accelerator limitation: 50 % or less</li> <li>• EGR stops</li> <li>• Intake air throttle valve fully open</li> <li>• Only main injection is allowed</li> </ul>	<ul style="list-style-type: none"> <li>• Faulty starting</li> <li>• Insufficient output</li> <li>• Worsening exhaust gas performance</li> <li>• Engine stops in some cases</li> </ul>	<ul style="list-style-type: none"> <li>• Diagnostic counter = 0</li> </ul>
Low boost pressure sensor abnormality	See Service Manual	P0237	102	4	<ul style="list-style-type: none"> <li>• Disconnection, short, or damage of harness</li> <li>• Battery fault</li> </ul>	<ul style="list-style-type: none"> <li>• Output limit: Q value of approx. 50 % or less</li> <li>• Accelerator limitation: 50 % or less</li> <li>• EGR stops</li> <li>• Intake air throttle valve fully open</li> </ul>	<ul style="list-style-type: none"> <li>• Faulty starting</li> <li>• Insufficient output</li> <li>• Worsening exhaust gas performance</li> </ul>	<ul style="list-style-type: none"> <li>• Key switch OFF</li> </ul>
High boost pressure sensor abnormality	See Service Manual	P0238	102	3	<ul style="list-style-type: none"> <li>• Injector ID code (correction data) read error</li> </ul>	<ul style="list-style-type: none"> <li>• Output limit: Q value of approx. 50 % or less</li> <li>• Accelerator limitation: 50 % or less</li> </ul>	<ul style="list-style-type: none"> <li>• Insufficient output</li> </ul>	<ul style="list-style-type: none"> <li>• Key switch OFF</li> </ul>
NE sensor pulse : No input	See Service Manual	P0335	636	8	<ul style="list-style-type: none"> <li>• Injector ID code (correction data) not written</li> </ul>	<ul style="list-style-type: none"> <li>• Output limit: Q value of approx. 50 % or less</li> <li>• Accelerator limitation: 50 % or less</li> </ul>	<ul style="list-style-type: none"> <li>• Insufficient output</li> </ul>	<ul style="list-style-type: none"> <li>• Key switch OFF</li> </ul>
NE sensor pulse number error → NE sensor pulse count abnormality	See Service Manual	P0336	636	2	<ul style="list-style-type: none"> <li>• ECU flash-ROM error</li> </ul>	<ul style="list-style-type: none"> <li>• Engine stop</li> </ul>	<ul style="list-style-type: none"> <li>• Engine stop</li> </ul>	<ul style="list-style-type: none"> <li>• Key switch OFF</li> </ul>
G sensor pulse : No input	See Service Manual	P0340	723	8	<ul style="list-style-type: none"> <li>• ECU CPU (main IC) error</li> </ul>	<ul style="list-style-type: none"> <li>• Engine stop</li> </ul>	<ul style="list-style-type: none"> <li>• Engine stop</li> </ul>	<ul style="list-style-type: none"> <li>• Key switch OFF</li> </ul>
G sensor pulse count abnormality	See Service Manual	P0341	723	2	<ul style="list-style-type: none"> <li>• ECU CPU (monitoring IC) error</li> </ul>	<ul style="list-style-type: none"> <li>• Engine stop</li> </ul>	<ul style="list-style-type: none"> <li>• Engine stop</li> </ul>	<ul style="list-style-type: none"> <li>• Key switch OFF</li> </ul>

# Handling Instructions

DTC name Text 1	Corrective action Text 2	ISO 14229 P-Code	J1939-73		Detected item <DM>	Limp Home Action by engine ECU (System action) <DM>	Behaviour During Malfunction <DM>	Recovery from error <DM>
			SPN	FMI				
Intake air heater relay actuation circuit, +B short	See Service Manual	P0380	52354 4	3	<ul style="list-style-type: none"> <li>Insufficient voltage in the ECU's injector actuation circuit</li> <li>Failure of ECU charge circuit</li> </ul>	<ul style="list-style-type: none"> <li>Output limit: Q value of approx. 50 % or less</li> <li>Accelerator limitation: 50% or less</li> <li>Rail pressure restriction: Command pressure <math>\leq</math> 80 MPa (820 kgf/cm<sup>2</sup>, 12000 psi)</li> <li>EGR stops</li> <li>Only main injection is allowed</li> </ul>	<ul style="list-style-type: none"> <li>Insufficient output</li> <li>Worsening exhaust gas performance</li> <li>Engine stops in some cases</li> </ul>	<ul style="list-style-type: none"> <li>Key switch OFF</li> </ul>
Short circuit of intake air heater relay actuation circuit to GND	See Service Manual	P0380	52354 4	4	<ul style="list-style-type: none"> <li>SCV disconnection or GND short</li> </ul>	<ul style="list-style-type: none"> <li>Output limit: Q value of approx. 50 % or less</li> <li>Accelerator limitation: 50 % or less</li> <li>Rail pressure restriction: Command pressure <math>\leq</math> 80 MPa (820 kgf/cm<sup>2</sup>, 12000 psi)</li> <li>EGR stops</li> </ul>	<ul style="list-style-type: none"> <li>Engine stop</li> </ul>	<ul style="list-style-type: none"> <li>Key switch OFF</li> </ul>
EGR motor disconnection malfunction	See Service Manual	P0403	52357 4	3	<ul style="list-style-type: none"> <li>SCV power supply short circuit</li> </ul>	<ul style="list-style-type: none"> <li>Output limit: Q value of approx. 50 % or less</li> <li>Accelerator limitation: 50 % or less</li> <li>Rail pressure restriction: Command pressure <math>\leq</math> 80 MPa (820 kgf/cm<sup>2</sup>, 12000 psi)</li> <li>EGR stops</li> </ul>	<ul style="list-style-type: none"> <li>Engine stop</li> </ul>	<ul style="list-style-type: none"> <li>Key switch OFF</li> </ul>

# Handling Instructions

DTC name Text 1	Corrective action Text 2	ISO 14229 P-Code	J1939-73		Detected item <DM>	Limp Home Action by engine ECU (System action) <DM>	Behaviour During Malfunction <DM>	Recovery from error <DM>
			SPN	FMI				
EGR motor short abnormality	See Service Manual	P0404	52357 4	4	<ul style="list-style-type: none"> <li>• Sensor supply voltage 1 abnormality or recognition error</li> </ul>	<ul style="list-style-type: none"> <li>• Output limit: Q value of approx. 50 % or less</li> <li>• Accelerator limitation: 50 % or less</li> <li>• Rail pressure restriction: Command pressure <math>\leq</math> 80 MPa (820 kgf/cm<sup>2</sup>, 12000 psi)</li> <li>• EGR stops</li> <li>• Intake air throttle valve: fully opened</li> </ul>	<ul style="list-style-type: none"> <li>• Faulty starting</li> <li>• Insufficient output</li> <li>• Worsening exhaust gas performance</li> <li>• Note: Engine stop</li> </ul>	<ul style="list-style-type: none"> <li>• Key switch OFF</li> </ul>
EGR position sensor error	See Service Manual	P0409	52357 2	4	<ul style="list-style-type: none"> <li>• Sensor supply voltage 1 abnormality or recognition error</li> </ul>	<ul style="list-style-type: none"> <li>• Output limit: Q value of approx. 50 % or less</li> <li>• Accelerator limitation: 50 % or less</li> <li>• Rail pressure restriction: Command pressure <math>\leq</math> 80 MPa (820 kgf/cm<sup>2</sup>, 12000 psi)</li> <li>• EGR stops</li> <li>• Intake air throttle valve: fully opened</li> </ul>	<ul style="list-style-type: none"> <li>• Faulty starting</li> <li>• Insufficient output</li> <li>• Worsening exhaust gas performance</li> <li>• Note: Engine stop</li> </ul>	<ul style="list-style-type: none"> <li>• Key switch OFF</li> </ul>
Low engine oil pressure abnormality	Stop ENG, See Service Manual	P0524	100	1	<ul style="list-style-type: none"> <li>• Sensor supply voltage 2 error or recognition error</li> </ul>	<ul style="list-style-type: none"> <li>• Output limit: Q value of approx. 50 % or less</li> <li>• Accelerator limitation: 50 % or less</li> </ul>	<ul style="list-style-type: none"> <li>• Faulty starting</li> <li>• Insufficient output</li> <li>• Worsening exhaust gas performance</li> </ul>	<ul style="list-style-type: none"> <li>• Key switch OFF</li> </ul>

# Handling Instructions

DTC name Text 1	Corrective action Text 2	ISO 14229 P-Code	J1939-73		Detected item <DM>	Limp Home Action by engine ECU (System action) <DM>	Behaviour During Malfunction <DM>	Recovery from error <DM>
			SPN	FMI				
Exhaust gas temperature sensor 1 (T1: DPOC outlet) Low	See Service Manual	P0543	3242	4	• Sensor supply voltage 2 error or recognition error	• Output limit: Q value of approx. 50 % or less • Accelerator limitation: 50 % or less	• Faulty starting • Insufficient output • Worsening exhaust gas performance	• Key switch OFF
Exhaust gas temperature sensor 1 (T1:DPOC outlet) High	See Service Manual	P0544	3242	3	• Main relay malfunction	None	• Dead battery	• Diagnostic counter = 0
Exhaust gas temperature sensor 0 (T0: DPOC intake) Low	See Service Manual	P0546	4765	4	• Sensor/ harness disconnection or GND short	• Accelerator limit: 25 % (Note: when accel sensors 1 and 2 are both abnormal)	• Insufficient output	• Diagnostic counter = 0
Exhaust gas temperature sensor 0 (T0:DPOC intake) High	See Service Manual	P0547	4765	3	• Sensor/wiring harness power supply short	• Accelerator limit: 25 % (Note: when accel sensors 1 and 2 are both abnormal)	• Insufficient output	• Diagnostic counter = 0
Battery voltage: Low	Stop ENG, See Service Manual	P0562	168	4	• Sensor/ harness disconnection or GND short	• Accelerator limit: 25 % (Note: when accel sensors 1 and 2 are both abnormal)	• Insufficient output	• Diagnostic counter = 0
Battery voltage: High	See Service Manual	P0563	168	3	• Sensor/wiring harness power supply short	• Accelerator limit: 25 % (Note: when accel sensors 1 and 2 are both abnormal)	• Insufficient output	• Diagnostic counter = 0
QR data abnormality	Contact dealer	P0602	52353 8	2	• Error received from the machine side	• Accelerator limit: 0 % fixation	• Insufficient output	• Diagnostic counter = 0
QR data abnormality (data write error)	Contact dealer	P0602	52353 8	7	• Disconnected injector actuation circuit open circuit (ECU side, common 1 system) or injector-side No. 1, 4 cylinder	• Output limit: Q value of approx. 50 % or less • Accelerator limitation: 50 % or less • EGR stops • Injection stops (No. 1, 4 cylinders)	• Insufficient output • Large vibrations • Worsening exhaust gas performance • Engine stops in some cases	• Key switch OFF

# Handling Instructions

DTC name Text 1	Corrective action Text 2	ISO 14229 P-Code	J1939-73		Detected item <DM>	Limp Home Action by engine ECU (System action) <DM>	Behaviour During Malfunction <DM>	Recovery from error <DM>
			SPN	FMI				
QR data abnormality (data write error)	Contact dealer	P0602	52353 8	7	simultaneous GND short	<ul style="list-style-type: none"> <li>• Output limit: Q value of approx. 50 % or less</li> <li>• Accelerator limitation: 50 % or less</li> <li>• EGR stops</li> <li>• Injection stops (No. 1, 4 cylinders)</li> </ul>	<ul style="list-style-type: none"> <li>• Insufficient output</li> <li>• Large vibrations</li> <li>• Worsening exhaust gas performance</li> <li>• Engine stops in some cases</li> </ul>	<ul style="list-style-type: none"> <li>• Key switch OFF</li> </ul>
ECU flash-ROM abnormality	Stop ENG, See Service Manual	P0605	628	2	<ul style="list-style-type: none"> <li>• Disconnected injector actuation circuit open circuit (ECU side, common 1 system) or injector-side No. 1, 4 cylinder simultaneous power supply short</li> </ul>	<ul style="list-style-type: none"> <li>• Output limit: Q value of approx. 50 % or less</li> <li>• Accelerator limitation: 50 % or less</li> <li>• EGR stops</li> <li>• Injection stops (No. 1, 4 cylinders)</li> </ul>	<ul style="list-style-type: none"> <li>• Insufficient output</li> <li>• Large vibrations</li> <li>• Worsening exhaust gas performance</li> <li>• Engine stops in some cases</li> </ul>	<ul style="list-style-type: none"> <li>• Key switch OFF</li> </ul>
ECU CPU abnormality (Main IC abnormality)	Stop ENG, See Service Manual	P0606	1077	2	<ul style="list-style-type: none"> <li>• Disconnected injector actuation circuit open circuit (ECU side, common 2 system) or injector-side No. 2, 3 cylinder simultaneous GND short</li> </ul>	<ul style="list-style-type: none"> <li>• Output limit: Q value of approx. 50 % or less</li> <li>• Accelerator limitation: 50 % or less</li> <li>• EGR stops</li> <li>• Injection stops (No. 2, 3 cylinders)</li> </ul>	<ul style="list-style-type: none"> <li>• Insufficient output</li> <li>• Large vibrations</li> <li>• Worsening exhaust gas performance</li> <li>• Engine stops in some cases</li> </ul>	<ul style="list-style-type: none"> <li>• Key switch OFF</li> </ul>
ECU CPU abnormality (monitoring IC)	Stop ENG, See Service Manual	P0606	52352 7	2	<ul style="list-style-type: none"> <li>• Disconnected injector actuation circuit open circuit (ECU side, common 2 system) or injector-side No. 2, 3 cylinder simultaneous power supply short</li> </ul>	<ul style="list-style-type: none"> <li>• Output limit: Q value of approx. 50 % or less</li> <li>• Accelerator limitation: 50 % or less</li> <li>• EGR stops</li> <li>• Injection stops (No. 2, 3 cylinders)</li> </ul>	<ul style="list-style-type: none"> <li>• Insufficient output</li> <li>• Large vibrations</li> <li>• Worsening exhaust gas performance</li> <li>• Engine stops in some cases</li> </ul>	<ul style="list-style-type: none"> <li>• Key switch OFF</li> </ul>

# Handling Instructions

DTC name Text 1	Corrective action Text 2	ISO 14229 P-Code	J1939-73		Detected item <DM>	Limp Home Action by engine ECU (System action) <DM>	Behaviour During Malfunction <DM>	Recovery from error <DM>
			SPN	FMI				
Insufficient ECU injector Charge Voltage	Stop ENG, See Service Manual	P0611	52352 5	1	<ul style="list-style-type: none"> <li>Short circuit of sensor/ECU internal circuit to ground</li> </ul>	<ul style="list-style-type: none"> <li>[Default value] 65 kPa (0.66 kgf/cm<sup>2</sup>, 9.4 psi)</li> </ul>	<ul style="list-style-type: none"> <li>Insufficient output</li> </ul>	<ul style="list-style-type: none"> <li>Diagnostic counter = 0</li> </ul>
SCV deive system abnormality	Stop ENG, See Service Manual	P0628	1347	4	<ul style="list-style-type: none"> <li>Short circuit of sensor/ECU internal circuit to power supply</li> </ul>	<ul style="list-style-type: none"> <li>[Default value] 65 kPa (0.66 kgf/cm<sup>2</sup>, 9.4 psi)</li> </ul>	<ul style="list-style-type: none"> <li>Insufficient output</li> </ul>	<ul style="list-style-type: none"> <li>Diagnostic counter = 0</li> </ul>
SCV +B short	Stop ENG, See Service Manual	P0629	1347	3	<ul style="list-style-type: none"> <li>CAN1 + B/ ground disconnection</li> <li>High traffic error</li> </ul>	<ul style="list-style-type: none"> <li>Output limit: Torque of 75 % or less</li> <li>EGR stops</li> </ul>	<ul style="list-style-type: none"> <li>Insufficient output</li> <li>Transmitted data is invalid</li> </ul>	<ul style="list-style-type: none"> <li>Key switch OFF</li> </ul>
Low sensor supply voltage 1	See Service Manual	P0642	3509	4	<ul style="list-style-type: none"> <li>CAN2 + B/ ground disconnection</li> <li>High traffic error</li> </ul>	<ul style="list-style-type: none"> <li>Accelerator limit: 0 % fixation</li> </ul>	<ul style="list-style-type: none"> <li>Insufficient output</li> <li>Transmitted data is invalid</li> </ul>	<ul style="list-style-type: none"> <li>Key switch OFF</li> </ul>
High sensor supply voltage 1	See Service Manual	P0643	3509	3	<ul style="list-style-type: none"> <li>CAN-KBT original frame disconnection abnormality</li> </ul>	<ul style="list-style-type: none"> <li>Accelerator limit: 0 % fixation</li> </ul>	<ul style="list-style-type: none"> <li>Insufficient output</li> </ul>	<ul style="list-style-type: none"> <li>Key switch OFF</li> </ul>
Low sensor supply voltage 2	See Service Manual	P0652	3510	4	<ul style="list-style-type: none"> <li>Sensor/ harness GND short circuit</li> <li>Sensor malfunction</li> </ul>	<ul style="list-style-type: none"> <li>[Default value] 25 °C</li> </ul>	<ul style="list-style-type: none"> <li>None</li> </ul>	<ul style="list-style-type: none"> <li>Diagnostic counter = 0</li> </ul>
High sensor supply voltage 2	See Service Manual	P0653	3510	3	<ul style="list-style-type: none"> <li>Sensor/ harness disconnection or power supply short</li> <li>Sensor malfunction</li> </ul>	<ul style="list-style-type: none"> <li>[Default value] 25 °C</li> </ul>	<ul style="list-style-type: none"> <li>None</li> </ul>	<ul style="list-style-type: none"> <li>Diagnostic counter = 0</li> </ul>
Main relay abnormality	See Service Manual	P0687	1485	2	<ul style="list-style-type: none"> <li>Insufficient engine intake air flow rate (turbo intake hose disconnected)</li> </ul>	<ul style="list-style-type: none"> <li>Output limit: Q value of approx. 50 % or less</li> <li>Accelerator limitation: 50 % or less</li> <li>EGR stops</li> </ul>	<ul style="list-style-type: none"> <li>Insufficient output</li> </ul>	<ul style="list-style-type: none"> <li>Key switch OFF</li> </ul>



# Handling Instructions

DTC name Text 1	Corrective action Text 2	ISO 14229 P-Code	J1939-73		Detected item <DM>	Limp Home Action by engine ECU (System action) <DM>	Behaviour During Malfunction <DM>	Recovery from error <DM>
			SPN	FMI				
Pump seizure 1	See Service Manual	P1274	52353 9	2	<ul style="list-style-type: none"> <li>• Sensor/harness disconnection or GND short</li> <li>• Sensor malfunction</li> </ul>	<ul style="list-style-type: none"> <li>• Output limit: Torque of 75 % or less</li> <li>• [Default value] Normal target intake air amount × 0.7</li> <li>• EGR stops</li> <li>• Intake air throttle valve fully open</li> </ul>	<ul style="list-style-type: none"> <li>• Insufficient output</li> <li>• Worsening exhaust gas performance</li> </ul>	<ul style="list-style-type: none"> <li>• Diagnostic counter = 0</li> </ul>
Pump seizure 2	See Service Manual	P1275	52354 0	2	<ul style="list-style-type: none"> <li>• Sensor/wiring harness power supply short</li> <li>• Sensor malfunction</li> </ul>	<ul style="list-style-type: none"> <li>• Output limit: Torque of 75 % or less</li> <li>• [Default value] Normal target intake air amount × 0.7</li> <li>• EGR stops</li> <li>• Intake air throttle valve fully open</li> </ul>	<ul style="list-style-type: none"> <li>• Insufficient output</li> <li>• Worsening exhaust gas performance</li> </ul>	<ul style="list-style-type: none"> <li>• Diagnostic counter = 0</li> </ul>
EEPROM check sum error	See Service Manual	P1990	52370 0	13	<ul style="list-style-type: none"> <li>• EGR valve motor disconnection</li> </ul>	<ul style="list-style-type: none"> <li>• Output limit: Torque of 75 % or less</li> <li>• EGR stops</li> </ul>	<ul style="list-style-type: none"> <li>• Insufficient output</li> <li>• Worsening exhaust gas performance</li> </ul>	<ul style="list-style-type: none"> <li>• Key switch OFF</li> </ul>
Aftertreatment system removal error	See Service Manual	P1A28	3936	7	<ul style="list-style-type: none"> <li>• EGR valve motor short circuit</li> </ul>	<ul style="list-style-type: none"> <li>• Output limit: Torque of 75 % or less</li> <li>• EGR stops</li> </ul>	<ul style="list-style-type: none"> <li>• Insufficient output</li> <li>• Worsening exhaust gas performance</li> </ul>	<ul style="list-style-type: none"> <li>• Key switch OFF</li> </ul>
ECU internal power supply error	See Service Manual	P1C00	52363 4	2	<ul style="list-style-type: none"> <li>• EGR Position sensor error</li> </ul>	<ul style="list-style-type: none"> <li>• Output limit: Torque of 75 % or less</li> <li>• EGR stops</li> </ul>	<ul style="list-style-type: none"> <li>• Insufficient output</li> <li>• Worsening exhaust gas performance</li> </ul>	<ul style="list-style-type: none"> <li>• Key switch OFF</li> </ul>
ECU internal IC error	See Service Manual	P1C01	52363 5	2	<ul style="list-style-type: none"> <li>• Sensor/harness GND short circuit</li> <li>• Sensor malfunction</li> </ul>	<ul style="list-style-type: none"> <li>• [Default value] 0 °C (32 °F)</li> </ul>	None	<ul style="list-style-type: none"> <li>• Key switch OFF</li> </ul>
ECU internal memory error	See Service Manual	P1C02	52363 6	2	<ul style="list-style-type: none"> <li>• Sensor/harness disconnection or</li> </ul>	<ul style="list-style-type: none"> <li>• [Default value] 0 °C (32 °F)</li> </ul>	None	<ul style="list-style-type: none"> <li>• Key switch OFF</li> </ul>

# Handling Instructions

DTC name Text 1	Corrective action Text 2	ISO 14229 P-Code	J1939-73		Detected item <DM>	Limp Home Action by engine ECU (System action) <DM>	Behaviour During Malfunction <DM>	Recovery from error <DM>
			SPN	FMI				
ECU internal memory error	See Service Manual	P1C02	52363 6	2	power supply short • Sensor malfunction	• [Default value] 0 °C (32 °F)	None	• Key switch OFF
Battery voltage too low	See Service Manual	P1C04	168	1	• Sensor/ harness GND short circuit • Sensor malfunction	• [Default value] 0 °C (32 °F)	None	• Key switch OFF
Intake air throttle feedback error	See Service Manual	P2108	52358 0	2	• Sensor/ harness disconnection or power supply short • Sensor malfunction	• [Default value] 0 °C (32 °F)	None	• Key switch OFF
Accel sensor 1: Low	See Service Manual	P2122	91	4	Kubota-EEPROM check sum error	None	-	Key switch turn OFF
Accel sensor 1: High	See Service Manual	P2123	91	3	• Intake air throttle DC motor feedback error	• Intake air throttle valve: fully opened	None	• Key switch OFF
Accel sensor 2: Low	See Service Manual	P2127	29	4	Deviation from designed correlation in two sensors	Forced Idle (Accelerator = 0 %)	- Insufficient output	Diagnostic counter = zero or Key switch turn OFF
Accel sensor 2: High	See Service Manual	P2128	29	3	• EGR valve stuck	• Output limit: Torque of 75 % or less • EGR stops	• Insufficient output • Worsening exhaust gas performance	• Key switch OFF
Accelerator Position Sensor Error (CAN)	See Service Manual	P2131	52354 3	2	• Abnormality in EGR valve motor's environmental temperature	• Output limit: Torque of 75 % or less • EGR stops	• Insufficient output • Worsening exhaust gas performance	• Key switch OFF
Accelerator position sensor correlation error	See Service Manual	P2135	91	2	• Abnormality in EGR valve built-in thermistor sensor	• Output limit: Torque of 75 % or less • EGR stops	• Insufficient output • Worsening exhaust gas performance	• Key switch OFF

# Handling Instructions

DTC name Text 1	Corrective action Text 2	ISO 14229 P-Code	J1939-73		Detected item <DM>	Limp Home Action by engine ECU (System action) <DM>	Behaviour During Malfunction <DM>	Recovery from error <DM>
			SPN	FMI				
Injector actuation circuit disconnection (COM1 or 1 & 4 cylinders simultaneously)	See Service Manual	P2146	52352 3	2	<ul style="list-style-type: none"> <li>• Sensor/harness GND short circuit</li> <li>• Sensor malfunction</li> </ul>	<ul style="list-style-type: none"> <li>• [Default value] 0 °C (32 °F)</li> </ul>	None	<ul style="list-style-type: none"> <li>• Key switch OFF</li> </ul>
GND short at either injector actuation circuit (COM1 or No.1 & 4 cylinders)	See Service Manual	P2147	52352 3	4	<ul style="list-style-type: none"> <li>• Sensor/harness disconnection or power supply short</li> <li>• Sensor malfunction</li> </ul>	<ul style="list-style-type: none"> <li>• [Default value] 0 °C (32 °F)</li> </ul>	None	<ul style="list-style-type: none"> <li>• Key switch OFF</li> </ul>
Battery short at either injector actuation circuit (COM1 or 1 & 4 cylinders)	Stop ENG, See Service Manual	P2148	52352 3	3	<ul style="list-style-type: none"> <li>• Sensor/harness GND short circuit</li> <li>• Sensor malfunction</li> </ul>	<ul style="list-style-type: none"> <li>• [Default value] 0 kPa (0.0 kgf/cm<sup>2</sup>, 0.0 psi)</li> </ul>	None	<ul style="list-style-type: none"> <li>• Key switch OFF</li> </ul>
Injector actuation circuit disconnection (COM2 or 2 & 3 cylinders simultaneously)	See Service Manual	P2149	52352 4	2	<ul style="list-style-type: none"> <li>• Sensor/harness disconnection or power supply short</li> <li>• Sensor malfunction</li> </ul>	<ul style="list-style-type: none"> <li>• [Default value] 0 kPa (0.0 kgf/cm<sup>2</sup>, 0.0 psi)</li> </ul>	None	<ul style="list-style-type: none"> <li>• Key switch OFF</li> </ul>
GND short at either injector actuation circuit (COM2 or No.2 & 3 cylinders)	See Service Manual	P2150	52352 4	4	<ul style="list-style-type: none"> <li>• Sensor/harness disconnection or GND short</li> <li>• Sensor malfunction</li> </ul>	<ul style="list-style-type: none"> <li>• Intake air throttle valve: fully opened</li> </ul>	None	<ul style="list-style-type: none"> <li>• Key switch OFF</li> </ul>
Battery short at either injector actuation circuit (COM2 or 2 & 3 cylinders)	Stop ENG, See Service Manual	P2151	52352 4	3	<ul style="list-style-type: none"> <li>• Sensor/wiring harness power supply short</li> <li>• Sensor malfunction</li> </ul>	<ul style="list-style-type: none"> <li>• Intake air throttle valve: fully opened</li> </ul>	None	<ul style="list-style-type: none"> <li>• Key switch OFF</li> </ul>
Atmospheric pressure sensor: Low	See Service Manual	P2228	108	4	<ul style="list-style-type: none"> <li>• DOC response error</li> </ul>	<ul style="list-style-type: none"> <li>• Output limit: Q value of approx. 50 % or less</li> <li>• Accelerator limitation: 50 % or less</li> <li>• EGR stops</li> <li>• Intake air throttle valve: fully opened</li> </ul>	<ul style="list-style-type: none"> <li>• Insufficient output</li> </ul>	<ul style="list-style-type: none"> <li>• Key switch OFF</li> </ul>

# Handling Instructions

DTC name Text 1	Corrective action Text 2	ISO 14229 P-Code	J1939-73		Detected item <DM>	Limp Home Action by engine ECU (System action) <DM>	Behaviour During Malfunction <DM>	Recovery from error <DM>
			SPN	FMI				
Atmospheric pressure sensor: High	See Service Manual	P2229	108	3	• DOC inlet temperature is high	• Engine stop • Starter relay is disabled and injection is stopped until the overall exhaust gas temperature drops to 300 °C (572 °F)	• Engine stop • Note: Cannot start until temperature reaches 300 °C (572 °F)	• Overall exhaust gas temperature is lower than 300 °C (572 °F) and key switch is OFF
EGR valve stick abnormality	See Service Manual	P2413	52357 5	7	• DOC outlet temperature is high	• Engine stop • Starter relay is disabled and injection is stopped until the overall exhaust gas temperature drops to 300 °C (572 °F)	• Engine stop • Note: Cannot start until temperature reaches 300 °C (572 °F)	• Overall exhaust gas temperature is lower than 300 °C (572 °F) and key switch is OFF
EGR motor environmental temperature abnormality	See Service Manual	P2414	52357 6	2	• DPF outlet temperature high	• Engine stop • EGR stops • Intake air throttle valve: fully closed • Starter relay is disabled and injection is stopped until the overall exhaust gas temperature drops to 300 °C (572 °F)	• Engine stop • Note: Cannot start until temperature reaches 300 °C (572 °F)	• Overall exhaust gas temperature is lower than 300 °C (572 °F) and key switch is OFF
EGR valve built-in thermistor sensor abnormality	See Service Manual	P2415	52357 7	2	• PM deposit error level (level 3)	• Output limit: Q value of approx. 50 % or less • Manual regeneration possible	• Insufficient output	• Diagnostic counter = 0
Exhaust gas temperature sensor 2 (T2: DPF outlet) Low	See Service Manual	P242C	3246	4	• Abnormal PM accumulation (level 4)	• Output limit: Q value of approx. 50 % or less • Manual regeneration not possible	• Insufficient output	• Diagnostic counter = 0

# Handling Instructions

DTC name Text 1	Corrective action Text 2	ISO 14229 P-Code	J1939-73		Detected item <DM>	Limp Home Action by engine ECU (System action) <DM>	Behaviour During Malfunction <DM>	Recovery from error <DM>
			SPN	FMI				
Exhaust gas temperature sensor 2 (T2: DPF outlet) High	See Service Manual	P242D	3246	3	<ul style="list-style-type: none"> <li>Abnormal PM accumulation (level 5)</li> </ul>	<ul style="list-style-type: none"> <li>Output limit: Q value of approx. 50 % or less</li> <li>Regeneration not possible</li> </ul>	<ul style="list-style-type: none"> <li>Insufficient output</li> </ul>	<ul style="list-style-type: none"> <li>Key switch OFF</li> </ul>
Differential pressure sensor: Low	See Service Manual	P2454	3251	4	<ul style="list-style-type: none"> <li>Insufficient intake air pressure increase (turbo outlet hose disconnected)</li> </ul>	<ul style="list-style-type: none"> <li>Output limit: Q value of approx. 50 % or less</li> <li>Accelerator limitation: 50 % or less</li> <li>EGR stops</li> </ul>	<ul style="list-style-type: none"> <li>Insufficient output</li> </ul>	<ul style="list-style-type: none"> <li>Key switch OFF</li> </ul>
Differential pressure sensor: High	See Service Manual	P2455	3251	3	<ul style="list-style-type: none"> <li>Coolant temperature is low during regeneration</li> </ul>	None	None	<ul style="list-style-type: none"> <li>Diagnostic counter = 0</li> </ul>
Intake air throttle lift sensor abnormality (low side)	See Service Manual	P2621	52358 3	4	<ul style="list-style-type: none"> <li>Regeneration times excessively long (exceeds required time)</li> </ul>	None	None	<ul style="list-style-type: none"> <li>Diagnostic counter = 0</li> </ul>
Intake air throttle lift sensor abnormality (high side)	See Service Manual	P2622	52358 3	3	<ul style="list-style-type: none"> <li>Simultaneous malfunction of all exhaust gas temperature sensors</li> </ul>	None	None	<ul style="list-style-type: none"> <li>Diagnostic counter = 0</li> </ul>
DOC response abnormality (exhaust gas abnormality)	See Service Manual	P3001	3252	0	<ul style="list-style-type: none"> <li>Exhaust gas temperature sensor 0, 1, 2 output</li> </ul>	<ul style="list-style-type: none"> <li>Engine stop</li> <li>Inhibit starter relay activation until all exhaust temp. (T0, T1, T2) reduces down to 300 degC (572 degF)</li> </ul>	None	<ul style="list-style-type: none"> <li>Diagnostic counter = zero or Key switch turn OFF</li> </ul>
Exhaust gas temperature increase error T0	Stop ENG, See Service Manual	P3002	4765	0	<ul style="list-style-type: none"> <li>Regeneration interval (interval between end of regeneration and next regeneration) is abnormal</li> </ul>	<ul style="list-style-type: none"> <li>Output limit: Q value of approx. 50 % or less</li> <li>Manual regeneration possible</li> <li>EGR stops</li> </ul>	<ul style="list-style-type: none"> <li>Worsening exhaust gas performance (NOx)</li> </ul>	<ul style="list-style-type: none"> <li>Key switch OFF</li> </ul>
Exhaust gas temperature increase error T1	Stop ENG, See Service Manual	P3003	3242	0	<ul style="list-style-type: none"> <li>EGR valve control state due to high temp of AECD</li> </ul>	None	<ul style="list-style-type: none"> <li>Worsening exhaust gas performance (NOx)</li> </ul>	<ul style="list-style-type: none"> <li>Diagnostic counter = 0</li> </ul>

# Handling Instructions

DTC name Text 1	Corrective action Text 2	ISO 14229 P-Code	J1939-73		Detected item <DM>	Limp Home Action by engine ECU (System action) <DM>	Behaviour During Malfunction <DM>	Recovery from error <DM>
			SPN	FMI				
Exhaust gas temperature increase error T2	Stop ENG, See Service Manual	P3004	3246	0	• Communication disrupted with EGR	• Output limit: Torque of 75 % or less • EGR stops	• Insufficient output • Worsening exhaust gas performance	• Key switch OFF
PM volume abnormality level3	Start DPF Parked Regeneration immediately	P3006	3701	15	• CAN_CCVS communication interruption error	• [Default value] Vehicle speed: 0 km, Parking: OFF	None	• Key switch OFF
PM volume abnormality level4	Stop engine!! Contact dealer immediately	P3007	3701	16	• CAN_CM1 communication interruption error	• [Default value] Manual regeneration input OFF, auto regeneration not possible	• Insufficient output	• Key switch OFF
PM volume abnormality level5	Stop engine!! Contact dealer immediately	P3008	3701	0	• CAN_TSC1 communication interruption error	• [Default value] TSC1 control not possible	• Insufficient output	• Key switch OFF
Insufficient turbo boost increase abnormality	See Service Manual	P3011	132	15	CAN_EBC1 communication stopping	Non shutdown [default value] Output limitation: Approximately 75% of normal condition	None	None
Insufficient rise in water temperature during parked/ manual regeneration	See Service Manual	P3012	52358 9	17	Remaining fuel volume at specified value or less (factory default setting=10%) Can be adjusted between 10 % and 80 %	None	None	Supply fuel until remaining fuel volume reaches the specified value or above
Increased parked/manual regeneration processing time abnormality	See Service Manual	P3013	52359 0	16	None	None	None	None
Loss of Function of DPF system (PCD) → Abnormal DPF function loss	See Service Manual	P3015	3936	3	• Sensitivity of differential pressure sensor is too low	None	• Worsening exhaust gas performance (increased PM)	• Diagnostic counter = 0

# Handling Instructions

DTC name Text 1	Corrective action Text 2	ISO 14229 P-Code	J1939-73		Detected item <DM>	Limp Home Action by engine ECU (System action) <DM>	Behaviour During Malfunction <DM>	Recovery from error <DM>
			SPN	FMI				
Simultaneous disconnection of all exhaust gas temp. sensors abnormality	See Service Manual	P3018	52359 9	0	• Sensor/ harness GND short circuit	• [Default value] During start-up = -20 °C (-4 °F) • [Default value] Other = 45 °C (113 °F)	None	• Diagnostic counter = 0
initial pump-calibration incomplete	See Service Manual	P3019	52360 0	0	• Sensor/ harness disconnection or power supply short	• [Default value] During start-up = -20 °C (-4 °F) • [Default value] Other = 45 °C (113 °F)	None	• Diagnostic counter = 0
High Exhaust Gas Temperature After Emergency High Temp. DTC	Stop ENG, See Service Manual	P3023	52360 1	0	• Abnormally high pressure 1	• Output limit: Q value of approx. 50 % or less • Accelerator limitation: 50 % or less • Rail pressure restriction: Command pressure <= 80 MPa (820 kgf/cm <sup>2</sup> , 12000 psi) • EGR stops	• Insufficient output • Worsening exhaust gas performance	• Key switch OFF
Abnormality frequent regeneration	See Service Manual	P3024	52360 2	0	• Abnormally high pressure 2	• Output limit: Q value of approx. 50 % or less • Accelerator limitation: 50 % or less • Rail pressure restriction: Command pressure <= 80 MPa (820 kgf/cm <sup>2</sup> , 12000 psi) • EGR stops	• Insufficient output • Worsening exhaust gas performance	• Key switch OFF

Handling Instructions

# Handling Instructions

DTC name Text 1	Corrective action Text 2	ISO 14229 P-Code	J1939-73		Detected item <DM>	Limp Home Action by engine ECU (System action) <DM>	Behaviour During Malfunction <DM>	Recovery from error <DM>
			SPN	FMI				
Over heat pre-caution (High.Temp-AECD activation warning)	Stop mowing!!	P3025	52360 3	15	<ul style="list-style-type: none"> <li>Disconnected injector actuation circuit open circuit (common 1 system) or injector-side No. 1, 4 cylinder simultaneous disconnection</li> </ul>	<ul style="list-style-type: none"> <li>Output limit: Q value of approx. 50 % or less</li> <li>Accelerator limitation: 50 % or less</li> <li>EGR stops</li> </ul>	<ul style="list-style-type: none"> <li>Insufficient output</li> <li>Large vibrations</li> <li>Worsening exhaust gas performance</li> <li>Engine stops in some cases</li> </ul>	<ul style="list-style-type: none"> <li>Key switch OFF</li> </ul>
CAN2 Bus off abnormality	See Service Manual	U0075	52354 7	2	<ul style="list-style-type: none"> <li>Disconnected injector actuation circuit open circuit (common 2 system) or injector-side No. 2, 3 cylinder simultaneous disconnection</li> </ul>	<ul style="list-style-type: none"> <li>Output limit: Q value of approx. 50 % or less</li> <li>Accelerator limitation: 50 % or less</li> <li>EGR stops</li> </ul>	<ul style="list-style-type: none"> <li>Insufficient output</li> <li>Large vibrations</li> <li>Worsening exhaust gas performance</li> <li>Engine stops in some cases</li> </ul>	<ul style="list-style-type: none"> <li>Key switch OFF</li> </ul>
EGR control line communication disruption (disconnection)	See Service Manual	U0076	52357 8	2	Fuel temp high	Output limitation: Approximately 75 % of normal condition	None	Diagnostic counter = zero or Key switch turn OFF
CAN1 Bus off abnormality	See Service Manual	U0077	52360 4	2	<ul style="list-style-type: none"> <li>Simultaneous disconnection of differential pressure sensor and all exhaust gas temperature sensors</li> </ul>	None	<ul style="list-style-type: none"> <li>Worsening exhaust gas performance (increased PM)</li> </ul>	<ul style="list-style-type: none"> <li>Diagnostic counter = 0</li> </ul>
CAN-KBT Frame error → CAN-KBT frame disconnection abnormality	See Service Manual	U0081	52354 8	2	Pump-calibration history	None	None	Diagnostic counter = zero or Key switch turn OFF
CAN_CCVS communication disruption abnormality	See Service Manual	U0082	52359 1	2	ECU internal power supply error	None	None	Key switch turn OFF
CAN_CM1 communication disruption abnormality	See Service Manual	U0083	52359 2	2	ECU internal IC error	None	None	Key switch turn OFF
CAN_TSC1 communication disruption abnormality	See Service Manual	U0087	52359 6	2	ECU internal memory error	Low idle	None	Key switch turn OFF
CAN EBC1 frame error	See Service Manual	U0089	52359 8	2	Open circuit, short circuit or damage of	Engine stop	Engine stops	Key switch turn OFF



# Handling Instructions

DTC name Text 1	Corrective action Text 2	ISO 14229 P-Code	J1939-73		Detected item <DM>	Limp Home Action by engine ECU (System action) <DM>	Behaviour During Malfunction <DM>	Recovery from error <DM>
			SPN	FMI				
CAN EBC1 frame error	See Service Manual	U0089	52359 8	2	harness Failure of battery	Engine stop	Engine stops	Key switch turn OFF
FUEL LEVEL LOW	Refuel	None	96	17	<ul style="list-style-type: none"> <li>• Large phase shift between NE (crankshaft position sensor) pulse and G (camshaft position sensor) pulse</li> </ul>	None	<ul style="list-style-type: none"> <li>• (Invalid G signal) engine hesitates at start-up</li> </ul>	<ul style="list-style-type: none"> <li>• Diagnostic counter = 0</li> </ul>
No fault code	None	None	916	17	<ul style="list-style-type: none"> <li>• Actual pressure is higher than command pressure</li> </ul>	<ul style="list-style-type: none"> <li>• Output limit: Q value of approx. 50 % or less</li> <li>• Accelerator limitation: 50 % or less</li> <li>• Rail pressure restriction: Command pressure <math>\leq</math> 80MPa (820 kgf/cm<sup>2</sup>, 12000 psi)</li> <li>• EGR stops</li> </ul>	<ul style="list-style-type: none"> <li>• Insufficient output</li> <li>• Worsening exhaust gas performance</li> </ul>	<ul style="list-style-type: none"> <li>• Diagnostic counter = 0</li> </ul>

# Handling Instructions

## ■List of Fault Codes

(#30048-)

### Important

When the fault code appears in the monitor display, refer to "Kubota DIAGNOSIS MANUAL" or contact your dealer.

The fault codes (DTC) and corresponding information that appear in the monitor display are listed below.

DTC name Text 1	Corrective action Text 2	ISO 14229 P-Code	J1939-73		Detected item <DM>	Limp Home Action by engine ECU (System action) <DM>	Behaviour During Malfunction <DM>	Recovery from error <DM>
			SPN	FMI				
NE-G phase shift	See Service Manual	P0016	636	7	Large deviation in phase between the crankshaft position sensor (NE) pulse signal and camshaft position sensor (G) pulse signal	<ul style="list-style-type: none"> <li>• Output restriction: about 75 %</li> </ul>	<ul style="list-style-type: none"> <li>• Engine hesitates at start-up</li> </ul>	Diagnostic counter = 0 (returns when error is resolved)
High rail pressure abnormality	See Service Manual	P0088	157	0	Actual pressure is higher than command pressure	<ul style="list-style-type: none"> <li>• Output limitation: approximately 50 % of normal condition</li> <li>• Speed limitation (accelerator limitation: 50 %)</li> <li>• EGR stops</li> <li>• Intake air throttle valve fully open</li> </ul>	<ul style="list-style-type: none"> <li>• Insufficient output</li> <li>• Worsening exhaust gas performance</li> </ul>	Diagnostic counter = 0 (returns when error is resolved)
SCV stuck	Stop ENG, See Service Manual	P0089	1347	7	Stuck at SCV valve open position (Actual rail pressure consistently higher than command railpressure)	<ul style="list-style-type: none"> <li>• Output limitation: approximately 50 % of normal condition</li> <li>• Speed limitation (accelerator limitation: 50 %)</li> <li>• EGR stops</li> <li>• Intake air throttle valve fully open</li> </ul>	<ul style="list-style-type: none"> <li>• Insufficient output</li> <li>• Worsening exhaust gas emissions</li> <li>• Engine may stop</li> </ul>	Key switch "OFF"

# Handling Instructions

DTC name Text 1	Corrective action Text 2	ISO 14229 P-Code	J1939-73		Detected item <DM>	Limp Home Action by engine ECU (System action) <DM>	Behaviour During Malfunction <DM>	Recovery from error <DM>
			SPN	FMI				
Fuel leak (high-pressure fuel system)	Stop ENG, See Service Manual	P0093	1239	1	Fuel leak from high pressure fuel system (Fuel consumption is calculated from the difference of fuel pressure of before and after the injection, and excess fuel consumption is found)	<ul style="list-style-type: none"> <li>• Output restriction: about 50 %</li> <li>• Accelerator limitation: 50 %</li> <li>• EGR stops</li> <li>• Intake air throttle valve fully open</li> </ul>	<ul style="list-style-type: none"> <li>• Insufficient output</li> <li>• Worsening exhaust gas performance</li> <li>• Engine may stop</li> </ul>	Key switch "OFF"
Intake air temperature sensor:Low	See Service Manual	P0112	172	4	Sensor/harness GND short circuit	<ul style="list-style-type: none"> <li>• [Default value] During start-up = -20 °C (-4 °F)</li> <li>• [Default value] Other than during start-up = 40 °C (104 °F)</li> </ul>	<ul style="list-style-type: none"> <li>• Increase in amount of white smoke at low temperature</li> </ul>	Diagnostic counter = 0 (returns when error is resolved)
Intake air temperature sensor: High	See Service Manual	P0113	172	3	Sensor/harness disconnection or power supply short	<ul style="list-style-type: none"> <li>• [Default value] During start-up = -20 °C (-4 °F)</li> <li>• [Default value] Other than during start-up = 40 °C (104 °F)</li> </ul>	<ul style="list-style-type: none"> <li>• Increase in amount of white smoke at low temperature</li> </ul>	Diagnostic counter = 0 (returns when error is resolved)
Coolant temperature sensor:Low	See Service Manual	P0117	110	4	Sensor/harness GND short circuit	<ul style="list-style-type: none"> <li>• [Default value] During start-up = -25 °C (-13 °F)</li> <li>• [Default value] Other than during start-up = 80 °C (176 °F)</li> <li>• Output restriction: about 75 %</li> <li>• EGR stops</li> <li>• Intake air throttle valve fully open</li> </ul>	<ul style="list-style-type: none"> <li>• Increase in amount of white smoke at low temperature</li> <li>• Insufficient output</li> <li>• Worsening exhaust gas performance</li> </ul>	Key switch "OFF"
Coolant temperature sensor:High	See Service Manual	P0118	110	3	Sensor/harness disconnection or	<ul style="list-style-type: none"> <li>• [Default value] During start-up</li> </ul>	<ul style="list-style-type: none"> <li>• Increase in amount of white</li> </ul>	Key switch "OFF"

# Handling Instructions

DTC name Text 1	Corrective action Text 2	ISO 14229 P-Code	J1939-73		Detected item <DM>	Limp Home Action by engine ECU (System action) <DM>	Behaviour During Malfunction <DM>	Recovery from error <DM>
			SPN	FMI				
Coolant temperature sensor:High	See Service Manual	P0118	110	3	power supply short	= -25 °C (-13 °F) • [Default value] Other than during start-up = 80 °C (176 °F) • Output restriction: about 75 % • EGR stops • Intake air throttle valve fully open	smoke at low temperature • Insufficient output • Worsening exhaust gas performance	Key switch "OFF"
Rail pressure sensor:Low	Stop ENG, See Service Manual	P0192	157	4	• Sensor/ harness GND short circuit • Malfunction of sensor	• Output restriction: about 50 % • Accelerator limitation: 50 % • EGR stops • Intake air throttle valve fully open • Engine forcibly stopped 60 sec later	• Insufficient output • Worsening exhaust gas performance • Worsening noise • Increase in white smoke • Engine stop	Key switch "OFF"
Rail pressure sensor:High	Stop ENG, See Service Manual	P0193	157	3	• Sensor/ harness disconnection or power supply short • Failure of sensor	• Output restriction: about 50 % • Accelerator limitation: 50 % • EGR stops • Intake air throttle valve fully open • Engine forcibly stopped 60 sec later	• Insufficient output • Worsening exhaust gas performance • Worsening noise • Increase in white smoke • Engine stop	Key switch "OFF"

# Handling Instructions

DTC name Text 1	Corrective action Text 2	ISO 14229 P-Code	J1939-73		Detected item <DM>	Limp Home Action by engine ECU (System action) <DM>	Behaviour During Malfunction <DM>	Recovery from error <DM>
			SPN	FMI				
ECU Injector charge voltage:High	Stop ENG, See Service Manual	P0200	52353 5	0	<ul style="list-style-type: none"> <li>• Voltage of ECU injector actuation is excessively large</li> <li>• ECU circuit failure</li> </ul>	<ul style="list-style-type: none"> <li>• Output limit: 75 % or less</li> <li>• EGR stops</li> <li>• Intake air throttle valve fully open</li> <li>• Engine forcibly stopped 60 sec later</li> </ul>	<ul style="list-style-type: none"> <li>• Insufficient output</li> <li>• Worsening exhaust gas performance</li> <li>• Engine stop</li> </ul>	Key switch "OFF"
Open circuit of harness/coil in 1st cylinder injector(TWV1)	See Service Manual	P0201	651	3	Engine No. 1 cylinder injector (TWV1) wiring harness open circuit, coil open circuit	<ul style="list-style-type: none"> <li>• Output restriction: about 75 %</li> <li>• EGR stops</li> <li>• Intake air throttle valve fully open</li> </ul>	<ul style="list-style-type: none"> <li>• Insufficient output</li> <li>• Increased vibration</li> <li>• Worsening exhaust gas performance</li> </ul>	Key switch "OFF"
Open circuit of harness/coil in 3rd cylinder injector (TWV2)	See Service Manual	P0202	653	3	Open circuit of harness/coil in 3rd cylinder injector (TWV2)	<ul style="list-style-type: none"> <li>• Output restriction: about 75 %</li> <li>• EGR stops</li> <li>• Intake air throttle valve fully open</li> </ul>	<ul style="list-style-type: none"> <li>• Insufficient output</li> <li>• Increased vibration</li> <li>• Worsening exhaust gas performance</li> </ul>	Key switch "OFF"
Open circuit of harness/coil in 4th cylinder injector (TWV3)	See Service Manual	P0203	654	3	Open circuit of harness/coil in 4th cylinder injector (TWV3)	<ul style="list-style-type: none"> <li>• Output restriction: about 75 %</li> <li>• EGR stops</li> <li>• Intake air throttle valve fully open</li> </ul>	<ul style="list-style-type: none"> <li>• Insufficient output</li> <li>• Increased vibration</li> <li>• Worsening exhaust gas performance</li> </ul>	Key switch "OFF"
Open circuit of harness/coil in 2nd cylinder injector (TWV4)	See Service Manual	P0204	652	3	Open circuit of harness/coil in 2nd cylinder injector (TWV4)	<ul style="list-style-type: none"> <li>• Output restriction: about 75 %</li> <li>• EGR stops</li> <li>• Intake air throttle valve fully open</li> </ul>	<ul style="list-style-type: none"> <li>• Insufficient output</li> <li>• Increased vibration</li> <li>• Worsening exhaust gas performance</li> </ul>	Key switch "OFF"
Engine overheat	Stop mowing!!	P0217	110	0	Abnormally high engine coolant temperature (Engine coolant temperature exceeds 120 °C (248 °F))	<ul style="list-style-type: none"> <li>• Output limit: Torque of 75 % or less</li> <li>• EGR stops</li> <li>• Intake air throttle valve fully open</li> </ul>	<ul style="list-style-type: none"> <li>• Insufficient output</li> <li>• Overheating</li> </ul>	Diagnostic counter = 0 (returns when error is resolved)

# Handling Instructions

DTC name Text 1	Corrective action Text 2	ISO 14229 P-Code	J1939-73		Detected item <DM>	Limp Home Action by engine ECU (System action) <DM>	Behaviour During Malfunction <DM>	Recovery from error <DM>
			SPN	FMI				
Engine overrun abnormality	See Service Manual	P0219	190	0	Engine speed exceeds threshold value	Injection stops (Q = 0 mm <sup>3</sup> /st)	• Engine overrun	Diagnostic counter = 0 (returns when error is resolved)
Boost pressure sensor: Low	See Service Manual	P0237	102	4	<ul style="list-style-type: none"> <li>• Sensor/harness disconnection or GND short</li> <li>• Sensor malfunction</li> </ul>	[Default value] 65 kPa (0.66 kgf/cm <sup>2</sup> , 9.4 psi)	• Insufficient output	Key switch "OFF"
Boost pressure sensor error: High	See Service Manual	P0238	102	3	<ul style="list-style-type: none"> <li>• Sensor/wiring harness power supply short</li> <li>• Sensor malfunction</li> </ul>	• [Default value] 65 kPa (0.66 kgf/cm <sup>2</sup> , 9.4 psi)	• Insufficient output	Key switch "OFF"
No pulse from crankshaft position sensor (NE sensor)	See Service Manual	P0335	636	8	<ul style="list-style-type: none"> <li>• Sensor/harness disconnection or short</li> <li>• Failure of sensor</li> </ul>	• Output restriction: about 75 %	<ul style="list-style-type: none"> <li>• Poor starting</li> <li>• Slight increase in vibration</li> <li>• Insufficient output (driven only by camshaft position sensor)</li> </ul>	Diagnostic counter = 0 (returns when error is resolved)
Crankshaft position sensor (NE sensor) pulse number error	See Service Manual	P0336	636	2	<ul style="list-style-type: none"> <li>• Sensor/harness disconnection or short</li> <li>• Failure of sensor</li> </ul>	• Output restriction: about 75 %	<ul style="list-style-type: none"> <li>• Poor starting</li> <li>• Slight increase in vibration</li> <li>• Insufficient output (driven only by camshaft position sensor)</li> </ul>	Diagnostic counter = 0 (returns when error is resolved)
No pulse from G-sensor (camshaft position sensor) pulse	See Service Manual	P0340	723	8	<ul style="list-style-type: none"> <li>• Sensor/harness disconnection or short</li> <li>• Failure of sensor</li> </ul>	• None	• Sluggish on startup	Diagnostic counter = 0 (returns when error is resolved)
G-sensor (camshaft position sensor) pulse number error	See Service Manual	P0341	723	2	<ul style="list-style-type: none"> <li>• Sensor/harness disconnection or short</li> <li>• Failure of sensor</li> </ul>	• None	• Hard to start	Diagnostic counter = 0 (returns when error is resolved)

# Handling Instructions

DTC name Text 1	Corrective action Text 2	ISO 14229 P-Code	J1939-73		Detected item <DM>	Limp Home Action by engine ECU (System action) <DM>	Behaviour During Malfunction <DM>	Recovery from error <DM>
			SPN	FMI				
Intake air heater relay actuation circuit, +B short	See Service Manual	P0380	52354 4	3	• Intake air heater relay actuation circuit, +B short	• None	• Faulty starting at low temperature • Increase of white smoke at low temperatures	Key switch "OFF"
Intake air heater relay drive circuit, ground short	See Service Manual	P0380	52354 4	4	• Short circuit of intake air heater relay drive circuit to GND	• None	• Faulty starting at low temperature • Increase of white smoke at low temperatures	Key switch "OFF"
Engine oil pressure low error	Stop ENG, See Service Manual	P0524	100	1	Oil pressure switch operation	• Engine stop	• Engine stop	Key switch "OFF"
Battery voltage:Low	Stop ENG, See Service Manual	P0562	168	4	• Disconnection, short, or damage of harness • Battery fault	• Output restriction: 75 % or less • EGR stops • Intake air throttle valve fully open	• Poor starting • Insufficient output • Worsening exhaust gas performance • Engine stops in some cases	Diagnostic counter = 0 (returns when error is resolved)
Battery voltage:High	See Service Manual	P0563	168	3	• Disconnection, short, or damage of harness • Battery fault	• Output restriction: 75 % or less • EGR stops • Intake air throttle valve fully open	• Poor starting • Insufficient output • Worsening exhaust gas performance	Key switch "OFF"
QR data error	Contact dealer	P0602	52353 8	2	• Injector ID code (correction data) read error	• Output restriction: 75% or less • Injection rate compensation not done	• Insufficient output	Key switch "OFF"
QR data error (data write error)	Contact dealer	P0602	52353 8	7	• Injector QR code (compensation data) not written	• Output restriction: 75% or less • Injection compensation= 0 (default value)	• Insufficient output	Key switch "OFF"

# Handling Instructions

DTC name Text 1	Corrective action Text 2	ISO 14229 P-Code	J1939-73		Detected item <DM>	Limp Home Action by engine ECU (System action) <DM>	Behaviour During Malfunction <DM>	Recovery from error <DM>
			SPN	FMI				
ECU flash-ROM error	Stop ENG, See Service Manual	P0605	628	2	• ECU flash- ROM error	• Engine stop	• Engine stop	Key switch "OFF"
ECU CPU Error (Main IC Error)	Stop ENG, See Service Manual	P0606	1077	2	• ECU CPU (main IC) error	• Engine stop	• Engine stop	Key switch "OFF"
ECU CPU error(monitored IC)	Stop ENG, See Service Manual	P0606	52352 7	2	• ECU CPU (monitored IC) error	• Engine stop	• Engine stop	Key switch "OFF"
Injector charge voltage: Low	Stop ENG, See Service Manual	P0611	52352 5	1	• Insufficient voltage in the ECU's injector drive circuit • Failure of ECU charge circuit	• Output restriction: 75 % or less • EGR stops • Intake air throttle valve fully open	• Insufficient output • Worsening exhaust gas performance • Engine stops in some cases	Key switch "OFF"
SCV drive system error	Stop ENG, See Service Manual	P0628	1347	4	• Open circuit or ground short circuit of SCV	• Output restriction: 50 % • Accelerator limitation: 50 % • Intake air throttle valve fully open • EGR stops • Engine stops 60 sec later	• Insufficient output • Worsening exhaust gas performance	Key switch "OFF"
+B short circuit of SCV (MPROP)	Stop ENG, See Service Manual	P0629	1347	3	• +B short circuit of SCV (MPROP)	• Output limitation: Approximately 50 % of normal condition, • Speed limitation (accelerator limitation: 50 %) • EGR stops • Intake throttle full open • Engine stops 60 seconds later	• Insufficient output • Worsening exhaust gas performance	• Starter switch stop



# Handling Instructions

DTC name Text 1	Corrective action Text 2	ISO 14229 P-Code	J1939-73		Detected item <DM>	Limp Home Action by engine ECU (System action) <DM>	Behaviour During Malfunction <DM>	Recovery from error <DM>
			SPN	FMI				
Sensor supply voltage1: Low	See Service Manual	P0642	3509	4	<ul style="list-style-type: none"> <li>• Sensor supply voltage 1 abnormality or recognition error</li> </ul>	<ul style="list-style-type: none"> <li>• Output restriction: 50 %</li> <li>• Speed limit (accelerator open limit: 50 %)</li> <li>• EGR stops</li> <li>• Intake air throttle valve fully open</li> </ul>	<ul style="list-style-type: none"> <li>• Poor starting</li> <li>• Insufficient output</li> <li>• Worsening exhaust gas performance</li> <li>• In such case engine stops</li> </ul>	Key switch "OFF"
Sensor supply voltage1: High	See Service Manual	P0643	3509	3	<ul style="list-style-type: none"> <li>• Sensor supply voltage 1 abnormality or recognition error</li> </ul>	<ul style="list-style-type: none"> <li>• Output limit: 50 % or less</li> <li>• Accelerator limitation: 50 % or less</li> <li>• EGR stops</li> <li>• Intake air throttle valve: fully opened</li> </ul>	<ul style="list-style-type: none"> <li>• Poor starting</li> <li>• Insufficient output</li> <li>• Worsening exhaust gas performance</li> <li>• In such case engine stops</li> </ul>	Key switch "OFF"
Sensor supply voltage 2: Low	See Service Manual	P0652	3510	4	<ul style="list-style-type: none"> <li>• Sensor supply voltage 2 error or recognition error</li> </ul>	<ul style="list-style-type: none"> <li>• Output restriction: 75 %</li> </ul>	<ul style="list-style-type: none"> <li>• Poor starting</li> <li>• Insufficient output</li> <li>• Worsening exhaust gas performance</li> </ul>	Key switch "OFF"
Sensor supply voltage 2:High	See Service Manual	P0653	3510	3	<ul style="list-style-type: none"> <li>• Sensor supply voltage 2 error or recognition error</li> </ul>	<ul style="list-style-type: none"> <li>• Output limit: 75 % or less</li> </ul>	<ul style="list-style-type: none"> <li>• Poor starting</li> <li>• Insufficient output</li> <li>• Worsening exhaust gas performance</li> </ul>	Key switch "OFF"
Main relay error	See Service Manual	P0687	1485	2	<ul style="list-style-type: none"> <li>• Main relay malfunction</li> </ul>	<ul style="list-style-type: none"> <li>• None</li> </ul>	<ul style="list-style-type: none"> <li>• Dead battery</li> </ul>	Diagnostic counter = 0 (returns when error is resolved)
Acceleration sensor1 :Low	See Service Manual	P2122	91	4	<ul style="list-style-type: none"> <li>• Sensor/harness disconnection or GND short</li> </ul>	<ul style="list-style-type: none"> <li>• Accelerator limitation: 0 %</li> </ul>	<ul style="list-style-type: none"> <li>• Insufficient output</li> </ul>	Diagnostic counter = 0 (returns when error is resolved)
Acceleration sensor1 :High	See Service Manual	P2123	91	3	<ul style="list-style-type: none"> <li>• Sensor/wiring harness power supply short</li> </ul>	<ul style="list-style-type: none"> <li>• Accelerator limitation: 0 %</li> </ul>	<ul style="list-style-type: none"> <li>• Insufficient output</li> </ul>	Diagnostic counter = 0 (returns when

# Handling Instructions

DTC name Text 1	Corrective action Text 2	ISO 14229 P-Code	J1939-73		Detected item <DM>	Limp Home Action by engine ECU (System action) <DM>	Behaviour During Malfunction <DM>	Recovery from error <DM>
			SPN	FMI				
Acceleration sensor1 :High	See Service Manual	P2123	91	3	• Sensor/wiring harness power supply short	• Accelerator limitation: 0 %	• Insufficient output	error is resolved)
Acceleration sensor2 :Low	See Service Manual	P2127	29	4	• Sensor/harness disconnection or GND short	• Accelerator limitation: 0 %	• Insufficient output	Diagnostic counter = 0 (returns when error is resolved)
Acceleration sensor2 :High	See Service Manual	P2128	29	3	• Sensor/wiring harness power supply short	• Accelerator limitation: 0 %	• Insufficient output	Diagnostic counter = 0 (returns when error is resolved)
Acceleration sensor error (CAN)	See Service Manual	P2131	52354 3	2	• Error received from the machine side	• None	• Insufficient output	Diagnostic counter = 0 (returns when error is resolved)
GND short at either injector actuation circuit (COM1 or No.1 & 4 cylinders)	See Service Manual	P2147	52352 3	4	• Wiring harness ground short	• Output restriction: 75 % • EGR stops • Injection stops (No. 1, 4 cylinders) • Intake air throttle valve fully open	• Insufficient output • Large vibrations • Worsening exhaust gas performance • Engine may stop	Key switch "OFF"
Battery short at either injector actuation circuit (COM1or1&4cylinders)	Stop ENG, See Service Manual	P2148	52352 3	3	• Wiring harness +B short	• Output restriction: 75 % • EGR stops • Injection stops (No. 1, 4 cylinders) • Intake air throttle valve fully open	• Insufficient output • Large vibrations • Worsening exhaust gas performance • Engine may stop	Key switch "OFF"
GND short at either injector actuation circuit (COM2 or No.2 & 3 cylinders)	See Service Manual	P2150	52352 4	4	• Wiring harness GND short	• Output restriction: 75 % • EGR stops • Injection stops (No. 2, 3 cylinders) • Intake air throttle valve fully open	• Insufficient output • Large vibrations • Worsening exhaust gas performance • Engine may stop	Key switch "OFF"

# Handling Instructions

DTC name Text 1	Corrective action Text 2	ISO 14229 P-Code	J1939-73		Detected item <DM>	Limp Home Action by engine ECU (System action) <DM>	Behaviour During Malfunction <DM>	Recovery from error <DM>
			SPN	FMI				
Battery short at either injector actuation circuit (COM2or2&3cylinders)	Stop ENG, See Service Manual	P2151	52352 4	3	• Wiring harness +B short	<ul style="list-style-type: none"> <li>• Output restriction: 75 %</li> <li>• EGR stops</li> <li>• Injection stops (No. 2, 3 cylinders)</li> <li>• Intake air throttle valve fully open</li> </ul>	<ul style="list-style-type: none"> <li>• Insufficient output</li> <li>• Large vibrations</li> <li>• Worsening exhaust gas performance</li> <li>• Engine may stop</li> </ul>	Key switch "OFF"
Atmospheric pressure sensor: Low	See Service Manual	P2228	108	4	• Short circuit of sensor/ECU internal circuit to ground	• [Default value] 65 kPa (0.66 kgf/cm <sup>2</sup> , 9.4 psi)	• Insufficient output	Diagnostic counter = 0 (returns when error is resolved)
Atmospheric pressure sensor: High	See Service Manual	P2229	108	3	• Short circuit of sensor/ECU internal circuit to power supply	• [Default value] 65 kPa (0.66 kgf/cm <sup>2</sup> , 9.4 psi)	• Insufficient output	Diagnostic counter = 0 (returns when error is resolved)
CAN1 bus off error	See Service Manual	U0077	52360 4	2	<ul style="list-style-type: none"> <li>• CAN1 and +B side or ground side short circuit</li> <li>• High traffic error</li> </ul>	<ul style="list-style-type: none"> <li>• Output restriction: 75 %</li> <li>• EGR stops</li> </ul>	<ul style="list-style-type: none"> <li>• Insufficient output</li> <li>• Transmitted CAN data invalid</li> </ul>	Key switch "OFF"
CAN2 bus off error	See Service Manual	U0075	52354 7	2	<ul style="list-style-type: none"> <li>• CAN2 and +B side or ground side short circuit</li> <li>• High traffic error</li> </ul>	• Accelerator limitation: 0 %	<ul style="list-style-type: none"> <li>• Insufficient output</li> <li>• Transmitted CAN data invalid</li> </ul>	Key switch "OFF"
CAN-KBT frame disconnection error	See Service Manual	U0081	52354 8	2	• CAN-KBT original frame disconnection error	• Accelerator limitation: 0 %	• Insufficient output	Key switch "OFF"
Intake air temperature built-in MAF sensor: Low	See Service Manual	P0072	171	4	Sensor/harness GND short circuit	• [Default value] 25 °C (77 °F)	• None	<ul style="list-style-type: none"> <li>• Diagnostic counter = 0 (returns when error is resolved)</li> <li>• Key switch "OFF"</li> </ul>
Intake air temperature built-in MAF sensor: High	See Service Manual	P0073	171	3	Sensor/harness open circuit or +B short	• [Default value] 25 °C (77 °F)	• None	• Diagnostic counter = 0 (returns when

# Handling Instructions

DTC name Text 1	Corrective action Text 2	ISO 14229 P-Code	J1939-73		Detected item <DM>	Limp Home Action by engine ECU (System action) <DM>	Behaviour During Malfunction <DM>	Recovery from error <DM>
			SPN	FMI				
Intake air temperature built-in MAF sensor: High	See Service Manual	P0073	171	3	Sensor/harness open circuit or +B short	<ul style="list-style-type: none"> <li>• [Default value] 25 °C (77 °F)</li> </ul>	<ul style="list-style-type: none"> <li>• None</li> </ul>	error is resolved) <ul style="list-style-type: none"> <li>• Key switch "OFF"</li> </ul>
Intake air volume: Low	See Service Manual	P0101	132	1	Insufficient engine intake air flow volume (turbo intake hose disconnected)	<ul style="list-style-type: none"> <li>• Output restriction: about 75 %</li> <li>• EGR stops</li> <li>• Intake air throttle valve fully open</li> </ul>	<ul style="list-style-type: none"> <li>• Insufficient output</li> <li>• Worsening exhaust gas performance</li> </ul>	Key switch "OFF"
MAF sensor: Low	See Service Manual	P0102	132	4	Sensor/harness disconnection or GND short	<ul style="list-style-type: none"> <li>• Output restriction: about 75 %</li> <li>• [Default value] Normal target intake air amount × 0.7</li> <li>• EGR stops</li> <li>• Intake air throttle valve fully open</li> </ul>	<ul style="list-style-type: none"> <li>• Insufficient output</li> <li>• Worsening exhaust gas performance</li> </ul>	Key switch "OFF"
MAF sensor: High	See Service Manual	P0103	132	3	Sensor/wiring harness power supply short	<ul style="list-style-type: none"> <li>• Output restriction: about 75 %</li> <li>• [Default value] Normal target intake air amount × 0.7</li> <li>• EGR stops</li> <li>• Intake air throttle valve fully open</li> </ul>	<ul style="list-style-type: none"> <li>• Insufficient output</li> <li>• Worsening exhaust gas performance</li> </ul>	Key switch "OFF"
EGR actuator open circuit	See Service Manual	P0403	52357 4	3	EGR valve motor disconnection	<ul style="list-style-type: none"> <li>• Output limit: Torque of 75 % or less</li> <li>• EGR stops</li> </ul>	<ul style="list-style-type: none"> <li>• Insufficient output</li> <li>• Worsening exhaust gas performance</li> </ul>	Key switch "OFF"
EGR actuator coil short	See Service Manual	P0404	52357 4	4	EGR valve motor short circuit	<ul style="list-style-type: none"> <li>• Output limit: Torque of 75 % or less</li> <li>• EGR stops</li> </ul>	<ul style="list-style-type: none"> <li>• Insufficient output</li> <li>• Worsening exhaust gas performance</li> </ul>	Key switch "OFF"

# Handling Instructions

DTC name Text 1	Corrective action Text 2	ISO 14229 P-Code	J1939-73		Detected item <DM>	Limp Home Action by engine ECU (System action) <DM>	Behaviour During Malfunction <DM>	Recovery from error <DM>
			SPN	FMI				
EGR position sensor failure	See Service Manual	P0409	52357 2	4	EGR Position sensor error	<ul style="list-style-type: none"> <li>Output limit: Torque of 75 % or less</li> <li>EGR stops</li> </ul>	<ul style="list-style-type: none"> <li>Insufficient output</li> <li>Worsening exhaust gas performance</li> </ul>	Key switch "OFF"
Exhaust gas temperature sensor1 (T1:DOC outlet): Low	See Service Manual	P0543	3242	4	<ul style="list-style-type: none"> <li>Sensor/harness GND short circuit</li> <li>Sensor malfunction</li> </ul>	<ul style="list-style-type: none"> <li>[Default value] 0 °C (32 °F)</li> <li>Output restriction: 75 %</li> </ul>	<ul style="list-style-type: none"> <li>None</li> </ul>	Key switch "OFF"
Exhaust gas temperature sensor1 (T1:DPOC outlet): High	See Service Manual	P0544	3242	3	<ul style="list-style-type: none"> <li>Sensor/harness disconnection or power supply short</li> <li>Sensor malfunction</li> </ul>	<ul style="list-style-type: none"> <li>[Default value] 0 °C (32 °F)</li> <li>Output restriction: 75 %</li> </ul>	<ul style="list-style-type: none"> <li>None</li> </ul>	Key switch "OFF"
Exhaust gas temperature sensor0 (T0:DOC intake): Low	See Service Manual	P0546	4765	4	<ul style="list-style-type: none"> <li>Sensor/harness GND short circuit</li> <li>Sensor malfunction</li> </ul>	<ul style="list-style-type: none"> <li>[Default value] 0 °C (32 °F)</li> <li>Output restriction: 75 %</li> </ul>	<ul style="list-style-type: none"> <li>None</li> </ul>	Key switch "OFF"
Exhaust gas temperature sensor 0 (T0:DOC inlet): High	See Service Manual	P0547	4765	3	<ul style="list-style-type: none"> <li>Sensor/harness disconnection or power supply short</li> <li>Sensor malfunction</li> </ul>	<ul style="list-style-type: none"> <li>[Default value] 0 °C (32 °F)</li> <li>Output restriction: 75 %</li> </ul>	<ul style="list-style-type: none"> <li>None</li> </ul>	Key switch "OFF"
EEPROM checksum error	See Service Manual	P1990	52370 0	13	• KBT-EEPROM checksum error	<ul style="list-style-type: none"> <li>None</li> </ul>	<ul style="list-style-type: none"> <li>None</li> </ul>	Key switch "OFF"
Intake throttle feedback (FB) error	See Service Manual	P2108	52358 0	2	<ul style="list-style-type: none"> <li>Intake air throttle DC motor feedback error</li> </ul>	<ul style="list-style-type: none"> <li>Output restriction: about 75 %</li> <li>Intake air throttle valve: fully opened</li> </ul>	<ul style="list-style-type: none"> <li>None</li> </ul>	Key switch "OFF"
Acceleration sensor correlation error	See Service Manual	P2135	91	2	<ul style="list-style-type: none"> <li>Excessive difference in sensor output of the 2 systems</li> </ul>	<ul style="list-style-type: none"> <li>Forced Idle (Accelerator position= 0 %)</li> </ul>	<ul style="list-style-type: none"> <li>Insufficient output</li> </ul>	Diagnostic counter = 0 (returns when error is resolved)

# Handling Instructions

DTC name Text 1	Corrective action Text 2	ISO 14229 P-Code	J1939-73		Detected item <DM>	Limp Home Action by engine ECU (System action) <DM>	Behaviour During Malfunction <DM>	Recovery from error <DM>
			SPN	FMI				
EGR valve stuck error	See Service Manual	P2413	52357 5	7	• EGR valve stuck	• Output restriction: 75 % or less • EGR stops	• Insufficient output • Worsening exhaust gas performance	Key switch "OFF"
EGR (DC motor) overheat	See Service Manual	P2414	52357 6	2	• Abnormality in EGR valve motor's environmental temperature	• Output restriction: 75 % or less • EGR stops	• Insufficient output • Worsening exhaust gas performance	Key switch "OFF"
EGR (DC motor) temperature sensor failure	See Service Manual	P2415	52357 7	2	• Abnormality in EGR valve built-in thermistor sensor	• Output restriction: 75 % or less • EGR stops	• Insufficient output • Worsening exhaust gas performance	Key switch "OFF"
Exhaust gas temperature sensor 2 (T2:DPF outlet): Low	See Service Manual	P242C	3246	4	• Sensor/harness GND short circuit • Sensor malfunction	• Output restriction: 75 % or less • [Default value] 0 °C (32 °F)	• None	Key switch "OFF"
Exhaust gas temperature sensor 2 (T2:DPF outlet): High	See Service Manual	P242D	3246	3	• Sensor/harness disconnection or power supply short • Sensor malfunction	• Output restriction: 75 % or less • [Default value] 0 °C (32 °F)	• None	Key switch "OFF"
Differential pressure sensor1: Low	See Service Manual	P2454	3251	4	• Sensor/harness GND short circuit • Sensor malfunction	• Output restriction: 75 % or less • [Default value] 0 kPa (0.0 kgf/cm <sup>2</sup> , 0.0 psi)	• None	Key switch "OFF"
Differential pressure sensor 1: High	See Service Manual	P2455	3251	3	• Sensor/harness disconnection or power supply short • Sensor malfunction	• Output restriction: 75 % or less • [Default value] 0 kPa (0.0 kgf/cm <sup>2</sup> , 0.0 psi)	• None	Key switch "OFF"

# Handling Instructions

DTC name Text 1	Corrective action Text 2	ISO 14229 P-Code	J1939-73		Detected item <DM>	Limp Home Action by engine ECU (System action) <DM>	Behaviour During Malfunction <DM>	Recovery from error <DM>
			SPN	FMI				
Intake throttle position sensor: Low	See Service Manual	P2621	52358 3	4	<ul style="list-style-type: none"> <li>• Sensor/ harness disconnection or GND short</li> <li>• Sensor malfunction</li> </ul>	<ul style="list-style-type: none"> <li>• Output restriction: about 75 %</li> <li>• Intake air throttle valve: fully opened</li> </ul>	<ul style="list-style-type: none"> <li>• None</li> </ul>	Key switch "OFF"
Intake throttle position sensor: High	See Service Manual	P2622	52358 3	3	<ul style="list-style-type: none"> <li>• Sensor/wiring harness power supply short</li> <li>• Sensor malfunction</li> </ul>	<ul style="list-style-type: none"> <li>• Output restriction: about 75 %</li> <li>• Intake air throttle valve: fully opened</li> </ul>	<ul style="list-style-type: none"> <li>• None</li> </ul>	Key switch "OFF"
DOC emission deterioration	See Service Manual	P3001	3252	0	<ul style="list-style-type: none"> <li>• High temperature DOC error due to unburned fuel gas</li> </ul>	<ul style="list-style-type: none"> <li>• Output restriction: 50 % or less</li> <li>• Accelerator limitation: 50 % or less</li> <li>• EGR stops</li> <li>• Intake air throttle valve: fully opened</li> </ul>	<ul style="list-style-type: none"> <li>• Insufficient output</li> </ul>	<ul style="list-style-type: none"> <li>• Exhaust gas temperature sensor T0</li> <li>• Exhaust gas temperature sensor T1</li> <li>• Exhaust gas temperature sensor T2</li> <li>• Intake air hose</li> <li>• Air flow sensor</li> <li>• Injector</li> </ul>
Exhaust gas temperature increase error T0	Stop ENG, See Service Manual	P3002	4765	0	<ul style="list-style-type: none"> <li>• DOC inlet temperature (T0) high temperature error</li> </ul>	<ul style="list-style-type: none"> <li>• Stop injection of injector</li> <li>• Engine stop</li> <li>• Starter relay drive stops until all exhaust temperature sensors drop below 300 °C (572 °F)</li> </ul>	<ul style="list-style-type: none"> <li>• Engine stop</li> <li>• Cannot start until temperature reaches 300 °C (572 °F)</li> </ul>	<ul style="list-style-type: none"> <li>• Overall exhaust gas temperature is lower than 300 °C (572 °F) and key switch is "OFF"</li> </ul>
Exhaust gas temperature increase error T1	Stop ENG, See Service Manual	P3003	3242	0	<ul style="list-style-type: none"> <li>• DPF inlet temperature (T1) error high</li> </ul>	<ul style="list-style-type: none"> <li>• Stop injection of injector</li> <li>• Engine stop</li> <li>• Starter relay drive stops until all exhaust temperature sensors drop below 300 °C (572 °F)</li> </ul>	<ul style="list-style-type: none"> <li>• Engine stop</li> <li>• Cannot start until temperature reaches 300 °C (572 °F)</li> </ul>	<ul style="list-style-type: none"> <li>• Overall exhaust gas temperature is lower than 300 °C (572 °F) and key switch is "OFF"</li> </ul>

# Handling Instructions

DTC name Text 1	Corrective action Text 2	ISO 14229 P-Code	J1939-73		Detected item <DM>	Limp Home Action by engine ECU (System action) <DM>	Behaviour During Malfunction <DM>	Recovery from error <DM>
			SPN	FMI				
Exhaust gas temperature increase error T2	Stop ENG, See Service Manual	P3004	3246	0	<ul style="list-style-type: none"> <li>• Temperature error for DPF outlet temperature (T2)</li> </ul>	<ul style="list-style-type: none"> <li>• Stop injection of injector</li> <li>• Engine stop</li> <li>• EGR stops</li> <li>• Target intake air throttle position 0 % (fully closed)</li> <li>• Starter relay drive stops until all exhaust temperature sensors drop below 300 °C (572 °F)</li> </ul>	<ul style="list-style-type: none"> <li>• Engine stop</li> <li>• Cannot start until temperature reaches 300 °C (572 °F)</li> </ul>	<ul style="list-style-type: none"> <li>• Overall exhaust gas temperature is lower than 300 °C (572 °F) and key switch is "OFF"</li> </ul>
Excessive PM3	Start DPF Parked Regeneration immediately	P3006	3701	15	<ul style="list-style-type: none"> <li>• Excessive PM3</li> </ul>	<ul style="list-style-type: none"> <li>• Output restriction: 50 %</li> </ul>	<ul style="list-style-type: none"> <li>• Insufficient output</li> </ul>	<ul style="list-style-type: none"> <li>• Diagnostic counter = 0 (returns when error is resolved)</li> </ul>
Excessive PM4	Stop engine!! Contact dealer immediately	P3007	3701	16	<ul style="list-style-type: none"> <li>• Excessive PM4</li> </ul>	<ul style="list-style-type: none"> <li>• Output restriction: 50 %</li> </ul>	<ul style="list-style-type: none"> <li>• Insufficient output</li> </ul>	<ul style="list-style-type: none"> <li>• Diagnostic counter = 0 (returns when error is resolved)</li> </ul>
Excessive PM5	Stop engine!! Contact dealer immediately	P3008	3701	0	<ul style="list-style-type: none"> <li>• Excessive PM5</li> </ul>	<ul style="list-style-type: none"> <li>• Output restriction: 50 %</li> </ul>	<ul style="list-style-type: none"> <li>• Insufficient output</li> </ul>	<ul style="list-style-type: none"> <li>• Key switch OFF (Reset error with the service tool)</li> </ul>
Insufficient turbo boost pressure increase error	See Service Manual	P3011	132	15	<ul style="list-style-type: none"> <li>• Hose disconnected between blower out and intake air flange</li> </ul>	<ul style="list-style-type: none"> <li>• Output restriction: 50 %</li> <li>• Accelerator limitation: 50 %</li> <li>• EGR stops</li> <li>• Intake air throttle valve fully open</li> </ul>	<ul style="list-style-type: none"> <li>• Insufficient output</li> </ul>	<ul style="list-style-type: none"> <li>• Key switch "OFF"</li> </ul>
Low coolant temperature in parked /manual regeneration	See Service Manual	P3012	52358 9	17	<ul style="list-style-type: none"> <li>• During regeneration, engine warm up condition not established (insufficient rise in coolant temperature)</li> </ul>	<ul style="list-style-type: none"> <li>• None</li> </ul>	<ul style="list-style-type: none"> <li>• None</li> </ul>	<ul style="list-style-type: none"> <li>• Diagnostic counter = 0 (returns when error is resolved) (parked active regeneration cancelled)</li> </ul>



# Handling Instructions

DTC name Text 1	Corrective action Text 2	ISO 14229 P-Code	J1939-73		Detected item <DM>	Limp Home Action by engine ECU (System action) <DM>	Behaviour During Malfunction <DM>	Recovery from error <DM>
			SPN	FMI				
Parked/manual regeneration time out	See Service Manual	P3013	52359 0	16	<ul style="list-style-type: none"> <li>During regeneration, DPF temperature fails to rise and regeneration does not complete. (Regeneration time)</li> </ul>	<ul style="list-style-type: none"> <li>None</li> </ul>	<ul style="list-style-type: none"> <li>None</li> </ul>	<ul style="list-style-type: none"> <li>Diagnostic counter = 0 (returns when error is resolved) (parked active regeneration cancelled)</li> </ul>
All exhaust temperature sensor failure	See Service Manual	P3018	52359 9	0	<ul style="list-style-type: none"> <li>All exhaust temperature sensor failure</li> </ul>	<ul style="list-style-type: none"> <li>None</li> </ul>	<ul style="list-style-type: none"> <li>None</li> </ul>	<ul style="list-style-type: none"> <li>Diagnostic counter = 0 (returns when error is resolved)</li> </ul>
Continued exhaust gas temperature error	Stop ENG, See Service Manual	P3023	52360 1	0	<ul style="list-style-type: none"> <li>Exhaust gas temperature sensor (T0, T1 and T2) output</li> </ul>	<ul style="list-style-type: none"> <li>Engine stop</li> <li>Inhibit starter relay activation until all exhaust gas temperatures (T0, T1 and T2) drop to 300 °C (572 °F)</li> </ul>	<ul style="list-style-type: none"> <li>None</li> </ul>	<ul style="list-style-type: none"> <li>Diagnostic counter = 0 (returns when error is resolved)</li> </ul>
High frequency of regeneration	See Service Manual	P3024	52360 2	0	<ul style="list-style-type: none"> <li>Abnormal interval between the end of one regeneration and the start of the next</li> </ul>	<ul style="list-style-type: none"> <li>Output restriction: 50 % or less</li> <li>EGR stops</li> </ul>	<ul style="list-style-type: none"> <li>Worsening exhaust gas performance (NOx)</li> </ul>	<ul style="list-style-type: none"> <li>Key switch "OFF" (Reset error with the service tool)</li> </ul>
Overheat warning	Stop mowing!!	P3025	52360 3	15	<ul style="list-style-type: none"> <li>Coolant temperature (Coolant temperature at least 110 °C (230 °F))</li> </ul>	<ul style="list-style-type: none"> <li>None</li> </ul>	<ul style="list-style-type: none"> <li>Worsening exhaust gas performance (NOx)</li> </ul>	<ul style="list-style-type: none"> <li>Diagnostic counter = 0 (returns when error is resolved)</li> </ul>
No communication with EGR	See Service Manual	U0076	52357 8	2	<ul style="list-style-type: none"> <li>Communication disrupted with EGR</li> </ul>	<ul style="list-style-type: none"> <li>Output restriction: 75 % or less</li> <li>EGR stops</li> </ul>	<ul style="list-style-type: none"> <li>Insufficient output</li> <li>Worsening exhaust gas performance</li> </ul>	<ul style="list-style-type: none"> <li>Key switch "OFF"</li> </ul>
CAN_CCVS communication interruption error	See Service Manual	U0082	52359 1	2	<ul style="list-style-type: none"> <li>CAN_CCVS communication interruption error</li> </ul>	<ul style="list-style-type: none"> <li>[Default value] Vehicle speed: 0 km, Parking: "OFF"</li> </ul>	<ul style="list-style-type: none"> <li>None</li> </ul>	<ul style="list-style-type: none"> <li>Key switch "OFF"</li> </ul>

# Handling Instructions

DTC name Text 1	Corrective action Text 2	ISO 14229 P-Code	J1939-73		Detected item <DM>	Limp Home Action by engine ECU (System action) <DM>	Behaviour During Malfunction <DM>	Recovery from error <DM>
			SPN	FMI				
CAN_CM1 communication interruption error	See Service Manual	U0083	52359 2	2	• CAN_CM1 communication interruption error	• [Default value] Manual regeneration input OFF, auto regeneration not possible	• Insufficient output	Key switch "OFF"
CAN_TSC1 frame error	See Service Manual	U0087	52359 6	2	• CAN_TSC1 frame error	• [Default value] override control mode=normal mode	• Insufficient output	• Diagnostic counter = 0 (returns when error is resolved)
CAN EBC1 frame error	See Service Manual	U0089	52359 8	2	CAN_EBC1 communication stopping	• Non shutdown [default value] • Output limitation: Approximately 75 % of normal condition	• None	• Diagnostic counter = 0 (returns when error is resolved) • Key switch turn OFF
Aftertreatment system removal error	See Service Manual	P1A28	3936	7	Aftertreatment system removal	• None	• None	• One of the differential pressure sensor, T0 temperature sensor, T1 temperature sensor, T2 temperaturesensor is normal
DPF function loss error	See Service Manual	P3015	3936	3	• Error in relationship between engine operating state and differential pressure	• None	• Worsening exhaust gas performance (increased PM)	• Diagnostic counter = 0 (returns when error is resolved)
Fuel temperature sensor: Low	See Service Manual	P0182	174	4	Sensor/harness GND short circuit	• [Default value] During start-up = -20 °C (-4 °F) • [Default value] Other than during start-up = 45 °C (113 °F) • Output restriction: about 75 %	• None	Key switch "OFF"

# Handling Instructions

DTC name Text 1	Corrective action Text 2	ISO 14229 P-Code	J1939-73		Detected item <DM>	Limp Home Action by engine ECU (System action) <DM>	Behaviour During Malfunction <DM>	Recovery from error <DM>
			SPN	FMI				
Fuel temperature sensor:High	See Service Manual	P0183	174	3	Sensor/harness GND short circuit	<ul style="list-style-type: none"> <li>• [Default value] During start-up = -20 °C (-4 °F)</li> <li>• [Default value] Other than during start-up = 45 °C (113 °F)</li> <li>• Output restriction: about 75 %</li> </ul>	<ul style="list-style-type: none"> <li>• None</li> </ul>	Key switch "OFF"
Pump seizing 1	See Service Manual	P1274	52353 9	2	• Abnormally high pressure 1	<ul style="list-style-type: none"> <li>• Output restriction: about 50 %</li> <li>• Accelerator limitation: 50 %</li> <li>• EGR stops</li> <li>• Intake air throttle valve fully open</li> </ul>	<ul style="list-style-type: none"> <li>• Insufficient output</li> <li>• Worsening exhaust gas performance</li> </ul>	Key switch "OFF"
Pump seizing 2	See Service Manual	P1275	52354 0	2	• Abnormally high pressure 2	<ul style="list-style-type: none"> <li>• Output restriction: about 50 %</li> <li>• Accelerator limitation: 50 %</li> <li>• EGR stops</li> <li>• Intake air throttle valve fully open</li> </ul>	<ul style="list-style-type: none"> <li>• Insufficient output</li> <li>• Worsening exhaust gas performance</li> </ul>	Key switch "OFF"
Injector actuation circuit disconnection (COM1or1&4cylinders simultaneously)	See Service Manual	P2146	52352 3	2	• Wiring harness open circuit	<ul style="list-style-type: none"> <li>• Output restriction: 75 %</li> <li>• EGR stops</li> <li>• Intake air throttle valve fully open</li> </ul>	<ul style="list-style-type: none"> <li>• Insufficient output</li> <li>• Large vibrations</li> <li>• Worsening exhaust gas performance</li> <li>• Engine may stop</li> </ul>	Key switch "OFF"

# Handling Instructions

DTC name Text 1	Corrective action Text 2	ISO 14229 P-Code	J1939-73		Detected item <DM>	Limp Home Action by engine ECU (System action) <DM>	Behaviour During Malfunction <DM>	Recovery from error <DM>
			SPN	FMI				
Injector actuation circuit disconnection (COM2or2&3cylinders simultaneously)	See Service Manual	P2149	52352 4	2	• Wiring harness open circuit	<ul style="list-style-type: none"> <li>• Output restriction: 75 %</li> <li>• EGR stops</li> <li>• Intake air throttle valve fully open</li> </ul>	<ul style="list-style-type: none"> <li>• Insufficient output</li> <li>• Large vibrations</li> <li>• Worsening exhaust gas performance</li> <li>• Engine may stop</li> </ul>	Key switch "OFF"
Fuel high temperature	See Service Manual	P0181	174	0	Fuel temperature high	<ul style="list-style-type: none"> <li>• Output restriction: 75 %</li> </ul>	<ul style="list-style-type: none"> <li>• None</li> </ul>	Diagnostic counter = zero or Key switch turn OFF
Initial pump calibration incomplete	See Service Manual	P3019	52360 0	0	• Pump calibration history	<ul style="list-style-type: none"> <li>• None</li> </ul>	<ul style="list-style-type: none"> <li>• None</li> </ul>	• Diagnostic counter = 0 (returns when error is resolved)
ECU internal power supply error	See Service Manual	P1C00	52363 4	2	ECU internal power supply error	<ul style="list-style-type: none"> <li>• None</li> </ul>	<ul style="list-style-type: none"> <li>• None</li> </ul>	Key switch "OFF"
ECU internal IC error	See Service Manual	P1C01	52363 5	2	ECU internal IC error	<ul style="list-style-type: none"> <li>• None</li> </ul>	<ul style="list-style-type: none"> <li>• None</li> </ul>	Key switch "OFF"
ECU internal memory error	See Service Manual	P1C02	52363 6	2	ECU internal memory error	Low idle	<ul style="list-style-type: none"> <li>• None</li> </ul>	Key switch "OFF"
Battery voltage too low	See Service Manual	P1C04	168	1	Open circuit, short circuit or damage of harness Failure of battery	Engine stop	- Engine stops	Key switch "OFF"
FUEL LEVEL LOW	Refuel	None	96	17	Remaining fuel volume at specified value or less (factory default setting=10 %) Can be adjusted between 10 % and 80 %	<ul style="list-style-type: none"> <li>• None</li> </ul>	<ul style="list-style-type: none"> <li>• None</li> </ul>	• Diagnostic counter = 0 (returns when error is resolved)

# Handling Instructions

## Engine Configuration

This function is not supported.

### 1-Up Display Setup

With "SETUP 1-UP DISPLAY", the displayed parameters can be reset to the factory defaults, or the monitor display of selected, necessary parameters can be set up. The following 3 items appear when "SETUP 1-UP DISPLAY" is selected.

- USE DEFAULTS
- CUSTOM SETUP
- AUTOMATIC SCAN

#### ■Use Defaults

With "USE DEFAULTS", the 1-up display parameters return to the factory defaults.

1. Press the menu key. After the main menu appears, use the arrow keys to highlight "SETUP 1-UP DISPLAY", and then press the Enter key.

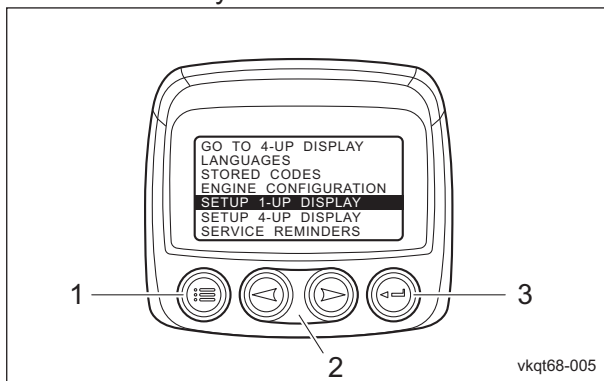

Use Defaults\_001

1	Menu key
2	Arrow keys
3	Enter key

2. Highlight "USE DEFAULTS", and then press the Enter key.

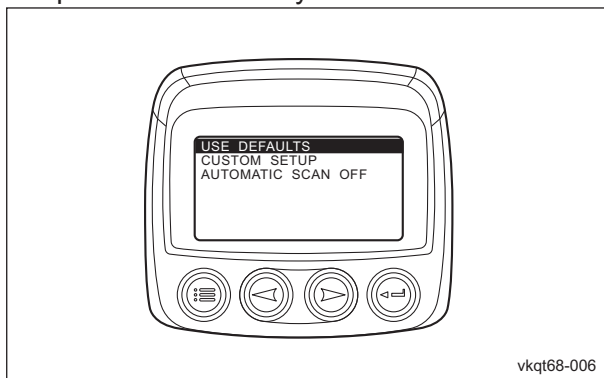

Use Defaults\_002

3. "RESTORED TO DEFAULTS" appears in the monitor display, and the parameters are reset to the factory defaults of the following 8 items.

- [1] ENGINE SPEED
- [2] ENGINE COOLANT TEMPERATURE
- [3] %SOOT
- [4] FUEL LEVEL
- [5] ENGINE OIL PRESSURE
- [6] MACHINE HOURS
- [7] BATTERY POTENTIAL
- [8] DPF STATUS

4. After the settings have been applied, pressing the menu key once returns to the main menu, and pressing the key again returns to the 1-up/4-up display screen.

#### ■Custom Setup

With "CUSTOM SETUP", the type and number of parameters as well as their display order can be specified.

1. Press the menu key. After the main menu appears, use the arrow keys to highlight "SETUP 1-UP DISPLAY", and then press the Enter key.

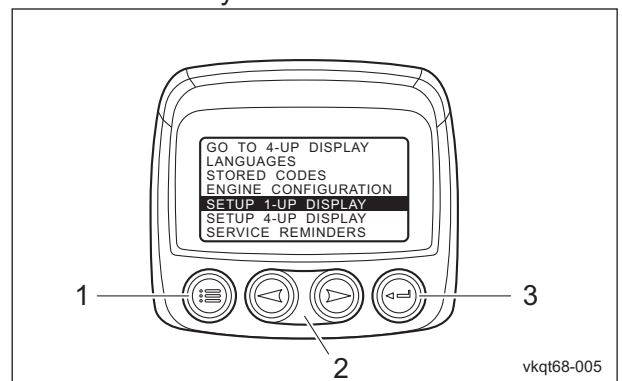

Custom Setup\_001

1	Menu key
2	Arrow keys
3	Enter key

# Handling Instructions

2. Highlight "CUSTOM SETUP", and then press the Enter key.  
The list of parameters appears.

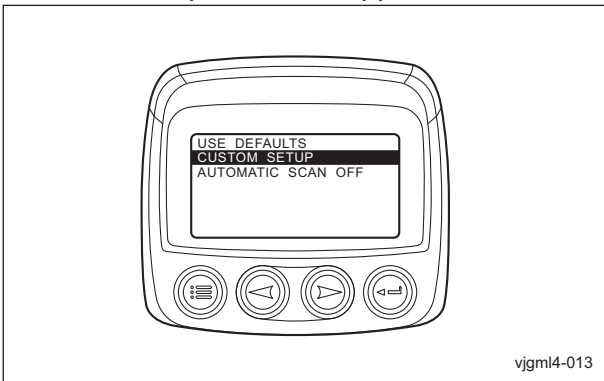

Custom Setup\_002

- [2] To deselect a parameter and remove it from the list of displayed parameters
  - a. Highlight the parameter, and then press the Enter key.

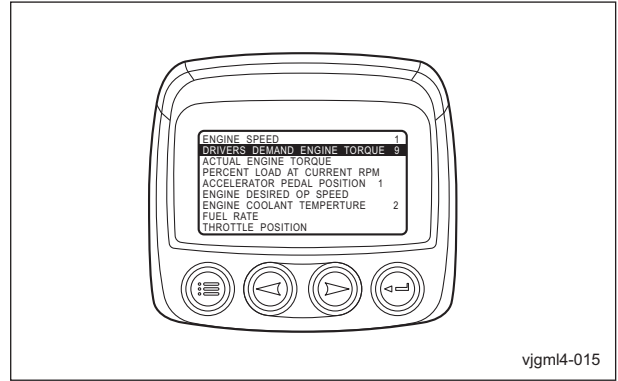

Custom Setup\_005

3. Change the parameters.

- [1] To add a parameter

- a. Use the arrow keys to highlight the parameter to be added, and then press the Enter key.

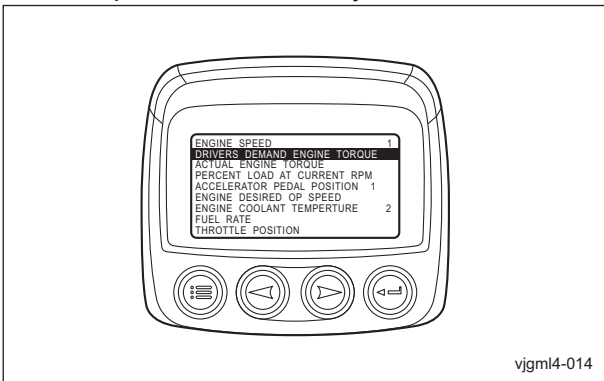

Custom Setup\_003

- b. Check that the number at the right of the parameter disappeared.

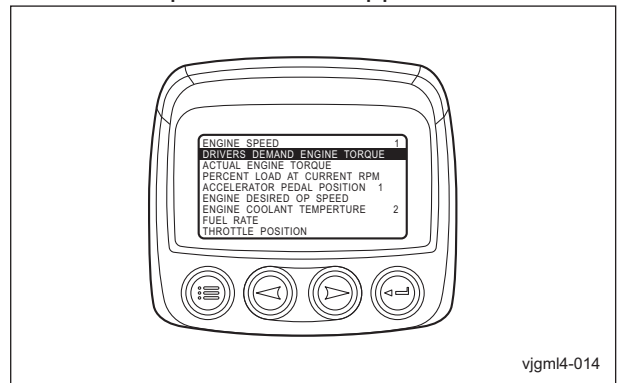

Custom Setup\_006

- b. A number appears at the right of the selected parameter. This number indicates the display order for the parameter

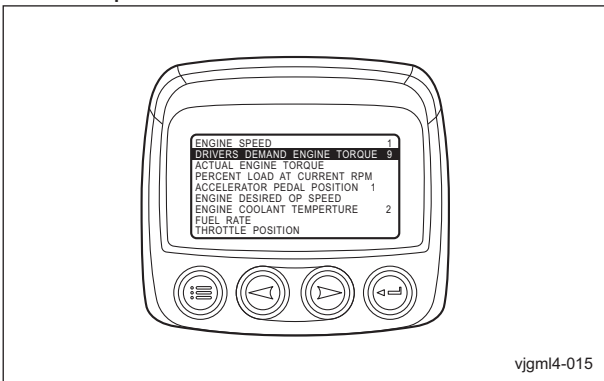

Custom Setup\_004

4. After the settings have been applied, pressing the menu key once returns to the main menu, and pressing the key again returns to the 1-up/4-up display screen.

# Handling Instructions

## Automatic Scan

With "AUTOMATIC SCAN", the 1-up display can be set to automatically scroll through the selected parameters one by one.

1. Press the menu key.

After the main menu appears, use the arrow keys to highlight "SETUP 1-UP DISPLAY", and then press the Enter key.

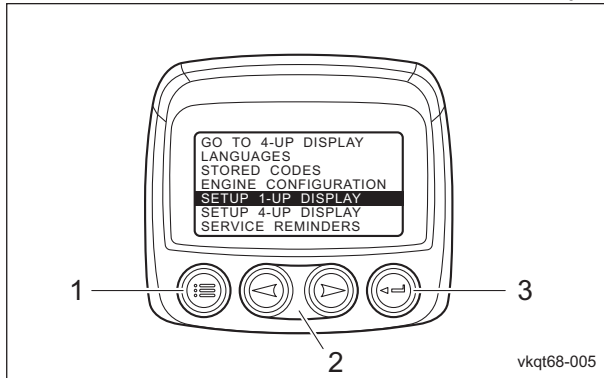

Automatic Scan\_001

1	Menu key
2	Arrow keys
3	Enter key

2. When "AUTOMATIC SCAN ON" appears, the parameters are scrolled automatically. For manual scrolling, highlight "AUTOMATIC SCAN ON", and then press the Enter key.

It turns into "AUTOMATIC SCAN OFF" and the parameters will be scrolled manually.

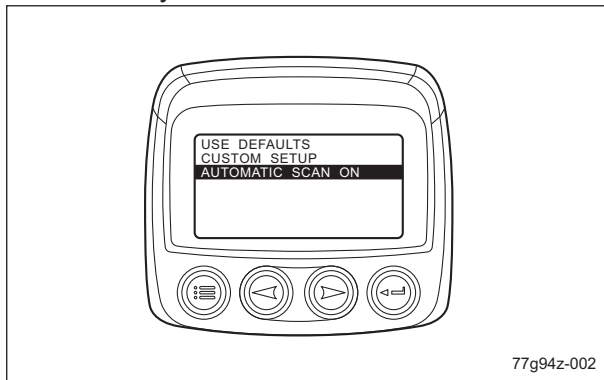

Automatic Scan\_002

3. After the settings have been applied, pressing the menu key once returns to the main menu, and pressing the key again returns to the 1-up/4-up display screen.

## Note:

When the parameters are scrolled automatically, press the Enter key once to pause scrolling.

When scrolling is paused, press the Enter key once to restart scrolling.

## 4-Up Display Setup

With "SETUP 4-UP DISPLAY", the displayed parameters can be reset to the factory defaults, or the monitor display of selected, necessary parameters can be set up. The following 2 items appear when "SETUP 4-UP DISPLAY" is selected.

- USE DEFAULTS
- CUSTOM SETUP

## Use Defaults

With "USE DEFAULTS", the 4-up display parameters return to the factory defaults.

1. Press the menu key.

After the main menu appears, use the arrow keys to highlight "SETUP 4-UP DISPLAY", and then press the Enter key.

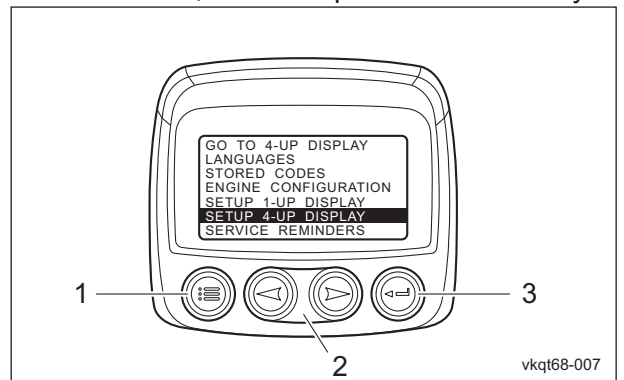

Use Defaults\_001

1	Menu key
2	Arrow keys
3	Enter key

# Handling Instructions

2. Highlight "USE DEFAULTS", and then press the Enter key.

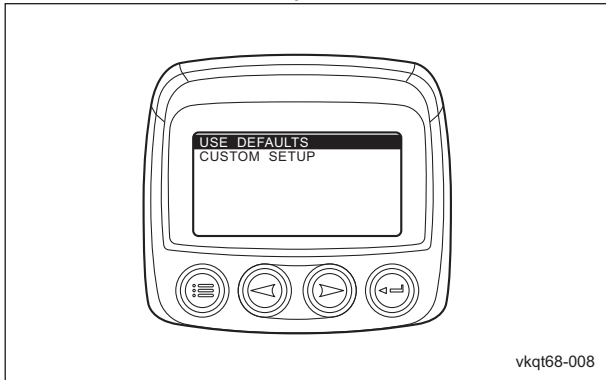

Use Defaults\_002

3. "RESTORED TO DEFAULTS" appears in the monitor display, and the parameters are reset to the factory defaults of the following 8 items.

- First page
  - [1] ENGINE SPEED
  - [2] ENGINE COOLANT TEMPERATURE
  - [3] %SOOT
  - [4] FUEL LEVEL
- Second page
  - [1] ENGINE OIL PRESSURE
  - [2] MACHINE HOURS
  - [3] BATTERY POTENTIAL
  - [4] DPF STATUS

4. After the settings have been applied, pressing the menu key once returns to the main menu, and pressing the key again returns to the 1-up/4-up display screen.

## ■ Custom Setup

With "CUSTOM SETUP", the type and number of parameters as well as their display order can be specified.

1. Press the menu key. After the main menu appears, use the arrow keys to highlight "SETUP 4-UP DISPLAY", and then press the Enter key.

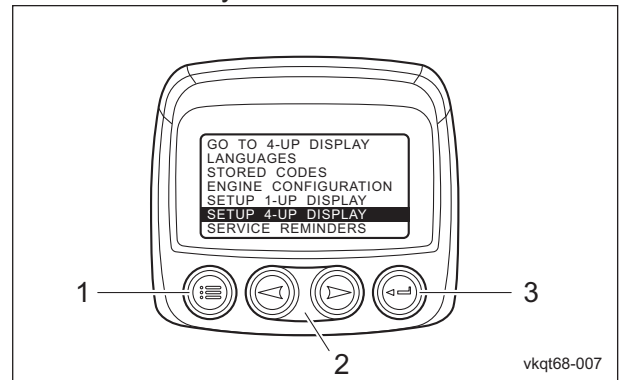

Custom Setup\_001

1	Menu key
2	Arrow keys
3	Enter key

2. Highlight "CUSTOM SETUP", and then press the Enter key.

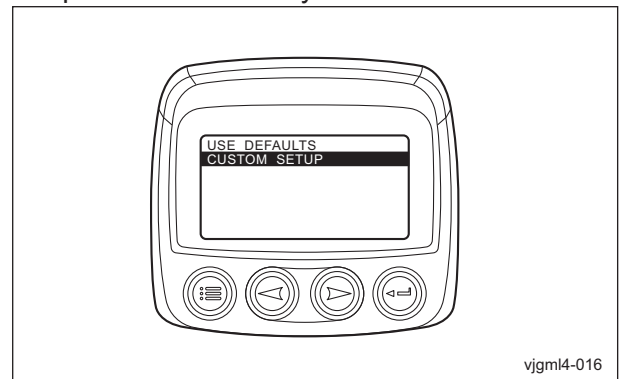

Custom Setup\_002



# Handling Instructions

### 3. Select the page.

- [1] Check that the values for the four parameters are highlighted.

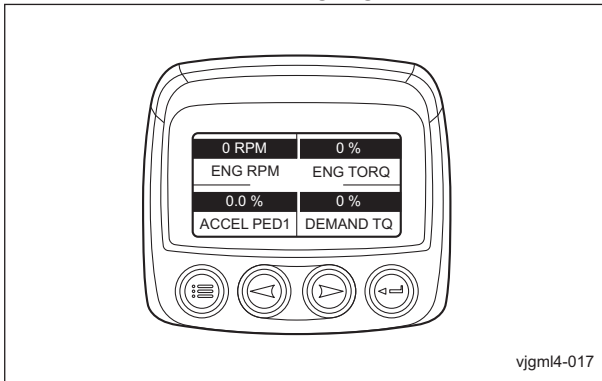

vjgml4-017

Custom Setup\_003

1	Parameter values
---	------------------

- [2] Use the arrow keys to display the page to be changed, and then press the Enter key.

### 4. Change the parameters.

- [1] Check that the value for one parameter is highlighted.

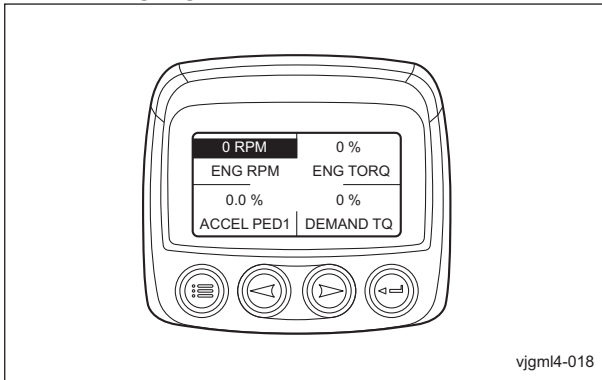

vjgml4-018

Custom Setup\_004

- [2] Use the arrow keys to highlight the value of the parameter to be changed, and then press the Enter key.

- [3] The parameters appear. The number at the right of the parameter indicates the location in the 4-up display.
  - 1=Upper left
  - 2=Lower left
  - 3=Upper right
  - 4=Lower right

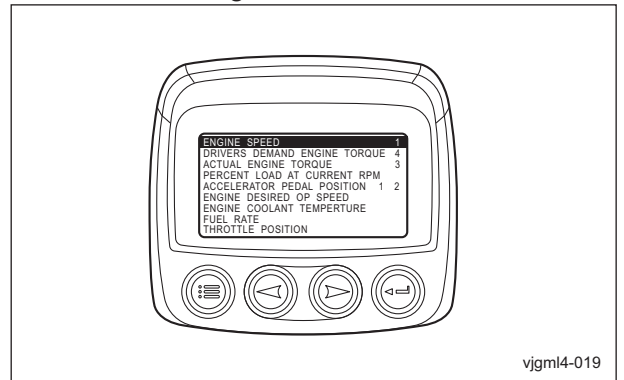

vjgml4-019

Custom Setup\_005

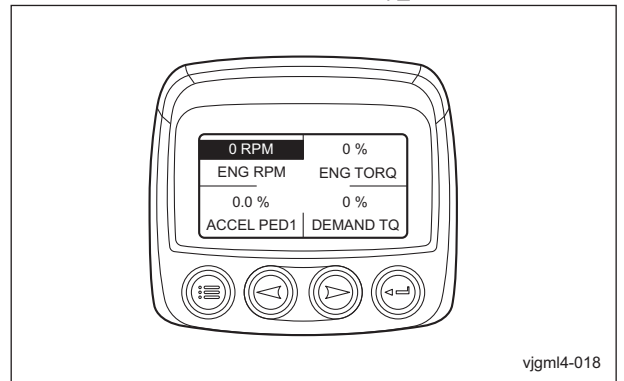

vjgml4-018

Custom Setup\_006

- [4] To change to a different parameter
  - a. Use the arrow keys to highlight the parameter to be selected, and then press the Enter key.

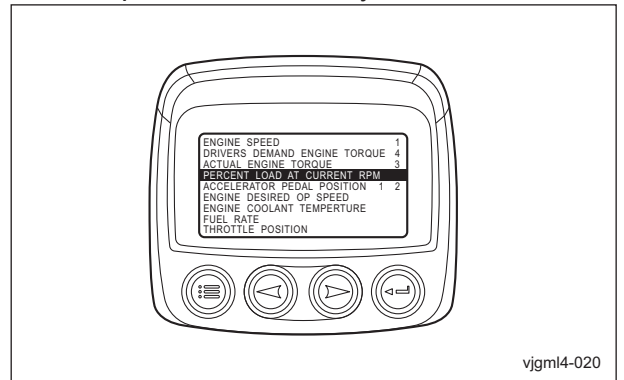

vjgml4-020

Custom Setup\_007

Handling Instructions

# Handling Instructions

b. Check that a number appeared to the right of the selected parameter.

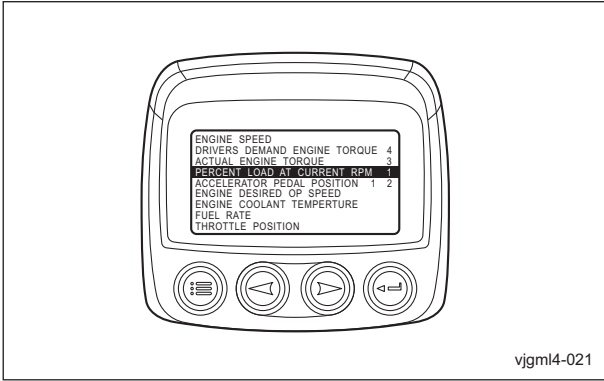

Custom Setup\_008

b. Check that the number at the right of the parameter disappeared.

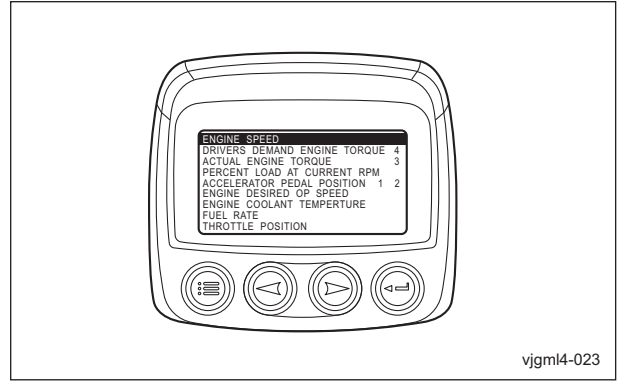

Custom Setup\_011

c. Press the menu key and check that the parameter has changed.

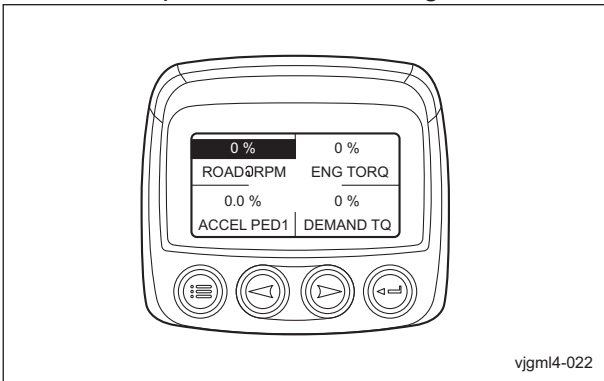

Custom Setup\_009

c. Press the menu key and check that the parameter has changed to "EMPTY".

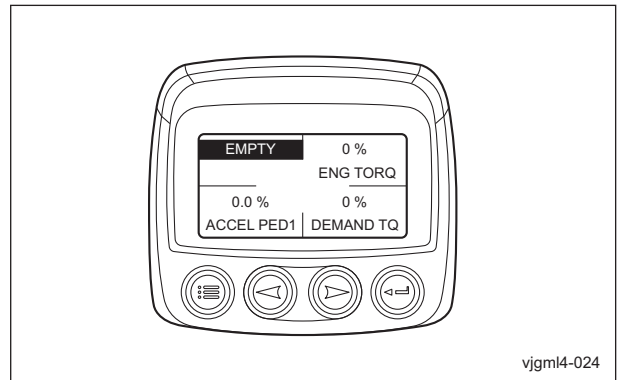

Custom Setup\_012

[5] To deselect a parameter and remove it from the list of displayed parameters

a. Highlight the parameter to be removed, and then press the Enter key.

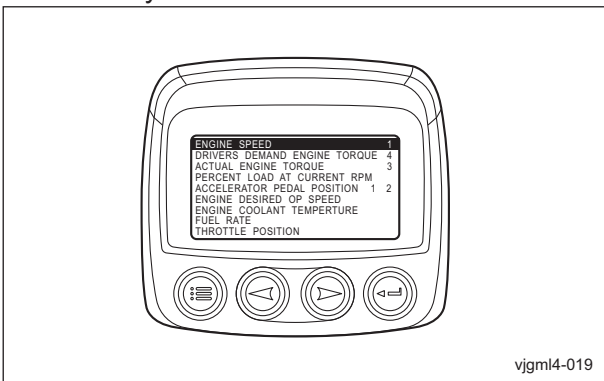

Custom Setup\_010

5. Pressing the menu key once returns to the display for selecting the page.
6. To change other parameters, repeat steps 3 to 5.

# Handling Instructions

## Service Reminders

With "SERVICE REMINDERS", the notification of replacement time for the following 5 consumables can be specified.

- Engine oil
- Engine oil filter
- Hydraulic oil
- Hydraulic oil filter
- Air cleaner

The following 2 items appear when "SERVICE REMINDERS" is selected.

- RESET REMINDERS
- MODIFY REMINDERS

### Reset Reminders

With "RESET REMINDER", displayed remaining time can be reset to the time specified with "MODIFY REMINDERS".

1. Press the menu key.

After the main menu appears, use the arrow keys to highlight "SERVICE REMINDERS", and then press the Enter key.

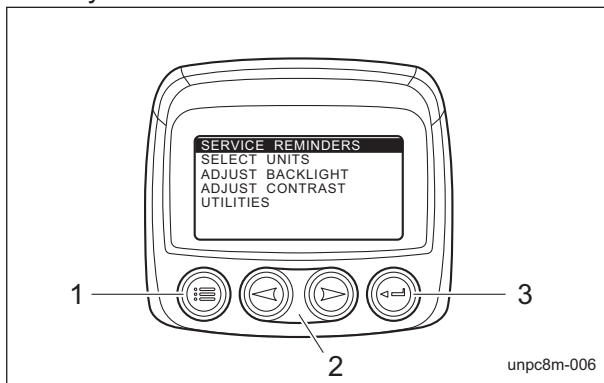

Reset Reminders\_001

1	Menu key
2	Arrow keys
3	Enter key

2. Highlight "RESET REMINDER", and then press the Enter key.

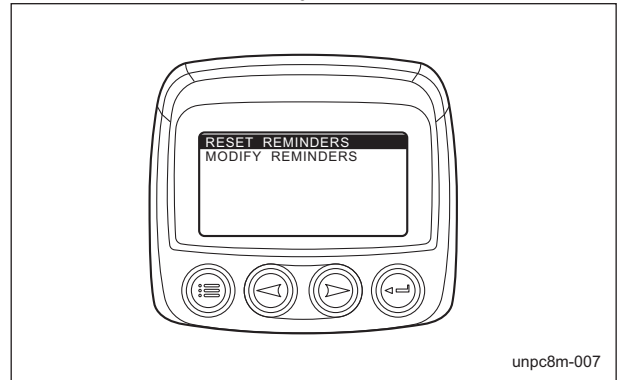

Reset Reminders\_002

3. Use the arrow keys to highlight the item to be changed, and then press the Enter key. A plus appears at the right of the currently selected items.

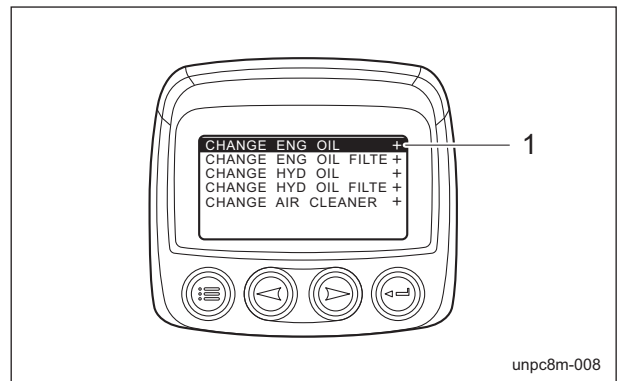

Reset Reminders\_003

1	Plus
---	------

4. The remaining time for the selected item appears.

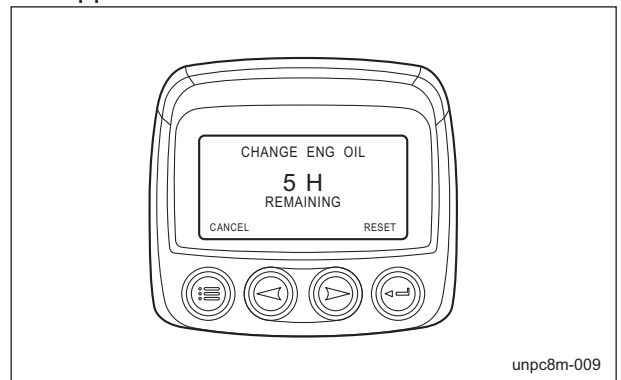

Reset Reminders\_004

[1] To reset the remaining time to the specified time, press the Enter key.

# Handling Instructions

- [2] "RESET SERVICE REMINDER?" appears.  
 To reset, press the Enter key.  
 To cancel resetting, press the menu key.



Reset Reminders\_005

2. Highlight "MODIFY REMINDERS", and then press the Enter key.

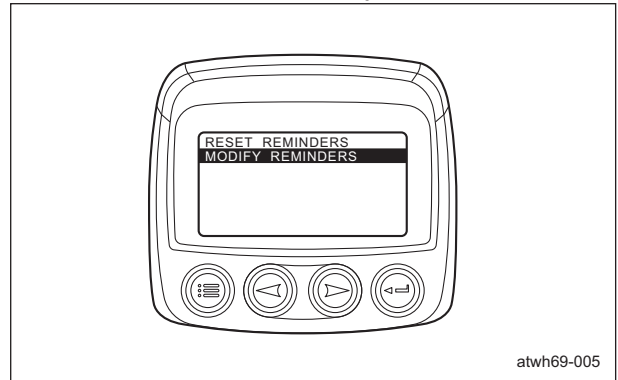

Modify Reminders\_002

3. Use the arrow keys to highlight the item to be changed, and then press the Enter key.

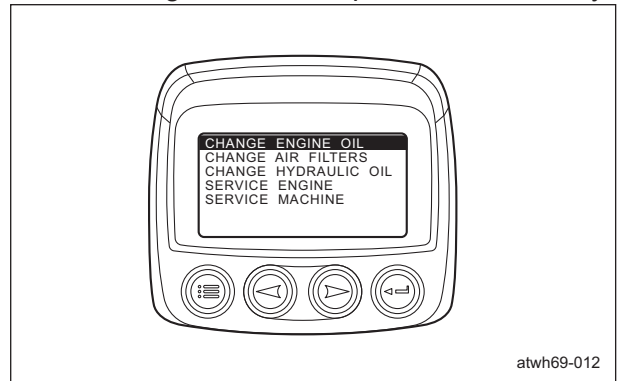

Modify Reminders\_003

4. The replacement time period for the selected item appears.

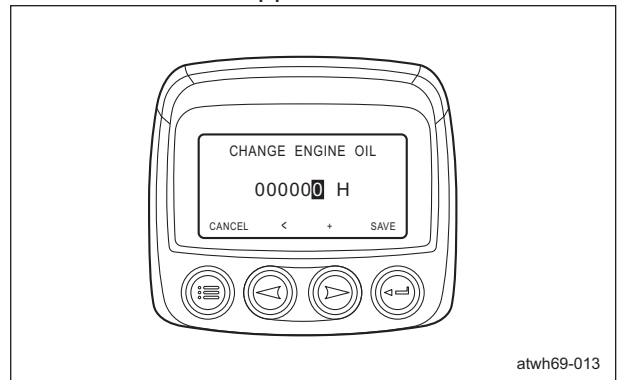

Modify Reminders\_004

5. The screen for selecting the item appears.

## ■Modify Reminders

With "MODIFY REMINDERS", the replacement time period for consumables can be specified.

The replacement time period is not configured at the factory.

Configure as necessary.

The replacement time period should be in accordance with the maintenance schedule.

1. Press the menu key.  
 After the main menu appears, use the arrow keys to highlight "SERVICE REMINDERS", and then press the Enter key.

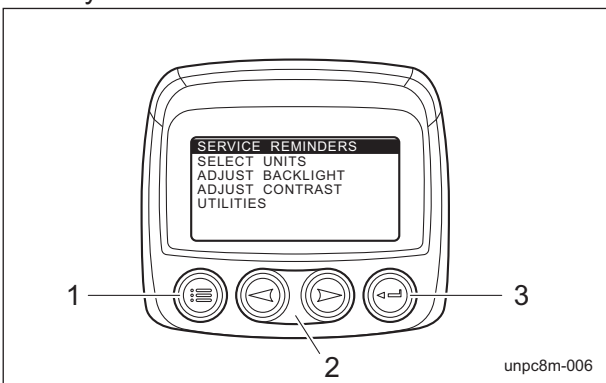

Modify Reminders\_001

1	Menu key
2	Arrow keys
3	Enter key

# Handling Instructions

- Highlight the digit to be changed. Press the right arrow key to increase the number. Press the left arrow key to change the digit.

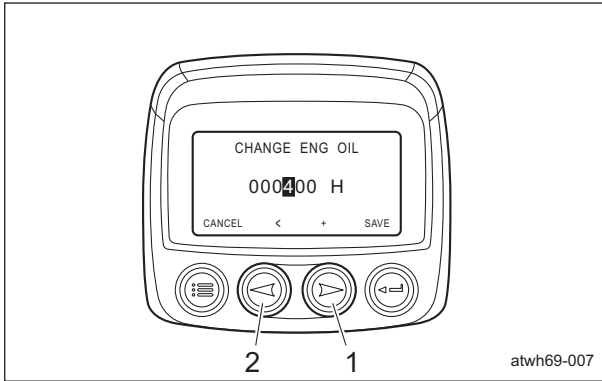

Modify Reminders\_005

1	Right arrow key
2	Left arrow key

- The display for selecting the item appears. A plus sign appears on the right side of the item with the replacement time period configured.

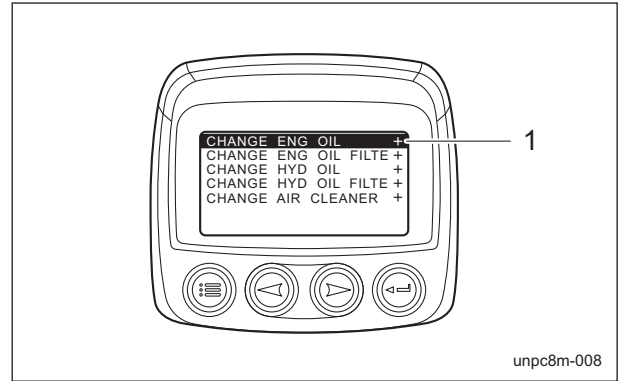

Modify Reminders\_007

1	Plus sign
---	-----------

- To save the specified time period, press the Enter key.
- "MODIFY SERVICE REMINDER?" appears. To save the changes, press the Enter key. To cancel the changes, press the menu key.

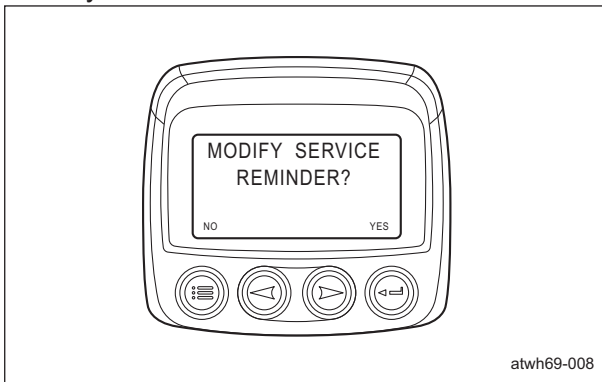

Modify Reminders\_006

## ■Reminder Display

### Important

If a warning message appears, immediately stop operation, and then perform the replacement procedure.

- When the specified replacement time period for a consumable has passed, a warning message appears in the monitor display and the LED (yellow) lights up.

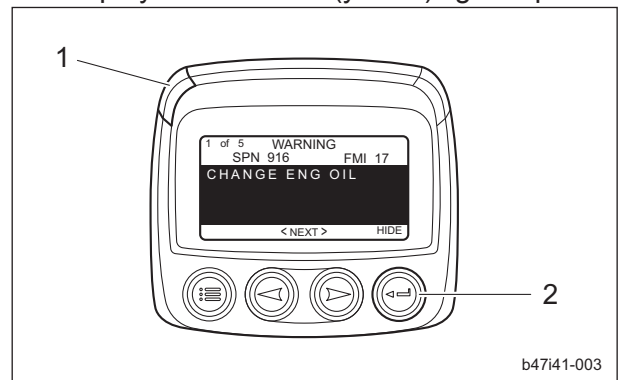

Reminder Display\_001

1	LED (yellow)
2	Enter key

# Handling Instructions

2. Pressing the Enter key changes the screen from the warning message to the parameter display.
3. A warning mark appears in the upper-right corner of the monitor display.

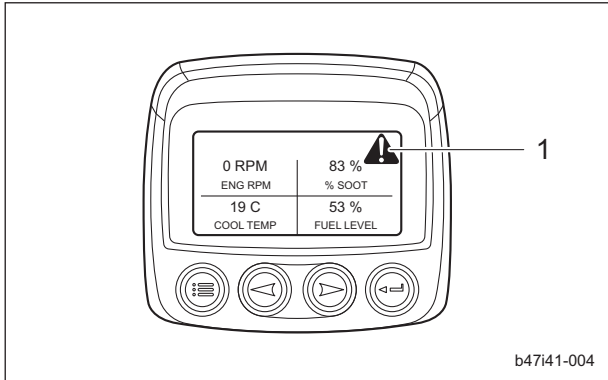

Reminder Display\_002

1	Warning mark
---	--------------

4. Change the replacement time period of consumables with "RESET REMINDERS" or "MODIFY REMINDERS".  
When the replacement time period is changed, the warning message and mark disappear.

### Select Units

(#30001-30047)

With "SELECT UNITS", the units of parameter values can be set to any of the following three formats.

- ENGLISH
- METRIC KPA
- METRIC BAR

An asterisk appears at the right of the currently selected unit.

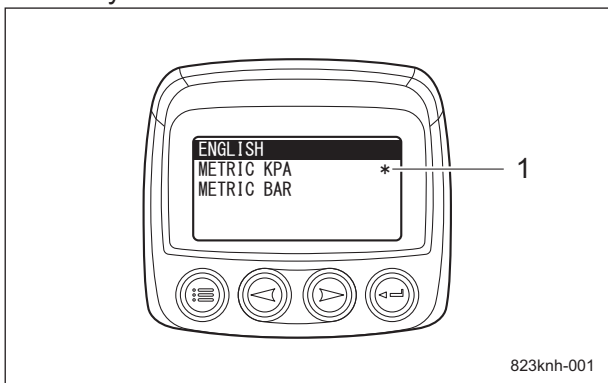

Select Units\_001

1	Asterisk
---	----------

No.	Monitor displays	Units		
		ENGLISH	METRIC KPA	METRIC BAR
1	ASH T	H	H	H
2	ENG RPM	RPM	RPM	RPM
3	DEMAND TQ	%	%	%
4	ENG TORQ	%	%	%
5	LOAD@RPM	%	%	%
6	ACCEL PED1	%	%	%
7	DES ENG SP	RPM	RPM	RPM
8	COOL TEMP	F	C	C
9	FUEL RATE	G/HR	L/HR	L/HR
10	THROTTLE	%	%	%
11	BST PRES	PSI	kPa	BAR
12	MANI TEMP	F	C	C
13	BAT VOLT	VDC	VDC	VDC
14	BARO PRES	PSI	kPa	BAR
15	AMB TEMP	F	C	C
16	AIR IN TP	F	C	C
17	FUEL USED	Gal	L	L
18	ENG HRS	H	H	H
19	OIL PRES	PSI	kPa	BAR
20	RAIL PRES	PSI	kPa	BAR
21	AIR RATE	kg/h	kg/h	kg/h
22	DOC TEMP	F	C	C
23	EF IN T	F	C	C
24	DIFF PRES	PSI	kPa	BAR
25	EF OUT T	F	C	C
26	PT LAMP	*	*	*
27	DPF ST	*	*	*
28	DPF AR ST	*	*	*
29	INHIBIT ST	*	*	*
30	DPF INHIB SW	*	*	*
31	EXH T LAMP	*	*	*
32	%SOOT	%	%	%
33	MACH HRS	H	H	H
34	FUEL LEVEL	%	%	%

Note:  
The factory default unit is "METRIC KPA".

# Handling Instructions

## Select Units

(#30048-)

With "SELECT UNITS", the units of parameter values can be set to any of the following three formats.

- ENGLISH
- METRIC KPA
- METRIC BAR

An asterisk appears at the right of the currently selected unit.

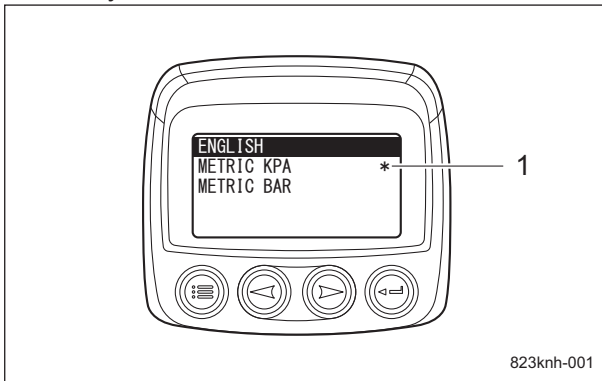

Select Units\_001

1	Asterisk
---	----------

No.	Monitor display S	Units		
		ENGLISH	METRIC KPA	METRIC BAR
1	ENG RPM	RPM	RPM	RPM
2	DEMAND TQ	%	%	%
3	ENG TORQ	%	%	%
4	LOAD@RPM	%	%	%
5	ACCEL PED1	%	%	%
6	DES ENG SP	RPM	RPM	RPM
7	COOL TEMP	F	C	C
8	FUEL RATE	G/HR	L/HR	L/HR
9	THROTTLE	%	%	%
10	BST PRES	PSI	kPa	BAR
11	MANI TEMP	F	C	C
12	BAT VOLT	VDC	VDC	VDC
13	BARO PRES	PSI	kPa	BAR
14	AMB TEMP	F	C	C
15	AIR IN TP	F	C	C
16	FUEL USED	Gal	L	L
17	ENG HRS	H	H	H
18	OIL PRES	PSI	kPa	BAR
19	RAIL PRES	PSI	kPa	BAR
20	AIR RATE	kg/h	kg/h	kg/h
21	DOC TEMP	F	C	C
22	EF IN T	F	C	C
23	DIFF PRES	PSI	kPa	BAR
24	EF OUT T	F	C	C
25	PT LAMP	*	*	*
26	DPF ST	*	*	*
27	DPF AR ST	*	*	*
28	INHIBIT ST	*	*	*
29	DPF INHIB SW	*	*	*
30	EXH T LAMP	*	*	*
31	%SOOT	%	%	%
32	MACH HRS	H	H	H
33	FUEL LEVEL	%	%	%

Note:

The factory default unit is "METRIC KPA".

# Handling Instructions

## Adjust Backlight

With "ADJUST BACKLIGHT", the brightness of the monitor display can be adjusted. Press the right arrow key to make the display brighter. Press the left arrow key to make the display darker.

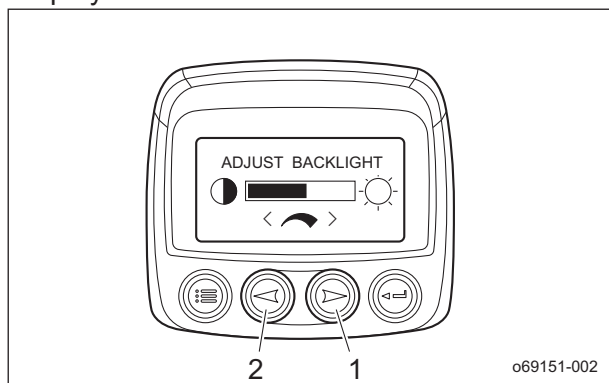

Adjust Backlight\_001

1	Right arrow key
2	Left arrow key

## Adjust Contrast

With "ADJUST CONTRAST", the contrast of the monitor display can be adjusted. Press the right arrow key to decrease the contrast. Press the left arrow key to increase the contrast.

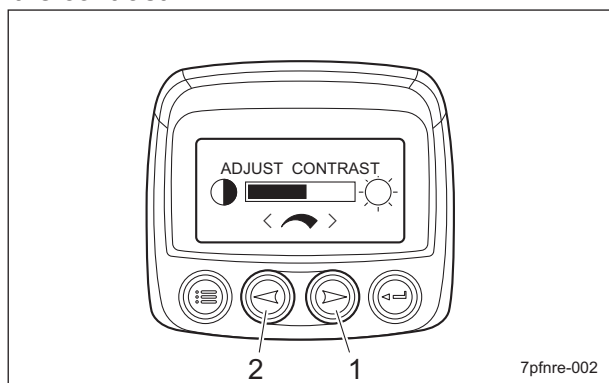

Adjust Contrast\_001

1	Right arrow key
2	Left arrow key

## Utilities

With "UTILITIES", the remaining fuel volume can be specified and the monitor configuration can be displayed.

The following 6 items appear when "UTILITIES" is selected.

- GAGE DATA
- REMOVE ALL GAGES
- SOFTWARE VERSION
- FAULT CONVERSION
- ANALOG INPUT
- OEM

Note:

"GAGE DATA" and "REMOVE ALL GAGES" are not supported on this machine.

### ■ Software Version

With "SOFTWARE VERSION", the software version of the monitor can be displayed.

### ■ Fault Conversion

With "FAULT CONVERSION", the J1939 fault code conversion method can be specified.

The monitor normally detects J1939 version 4.

Since the engine ECU of this machine uses J1939 version 4, no adjustments are necessary.

### ■ Analog Input

With "ANALOG INPUT", remaining fuel volume information can be specified.

The following 2 items appear when "ANALOG INPUT" is selected.

- BACKLIGHT DIMMER
- FUEL LEVEL

### Important

"BACKLIGHT DIMMER" is not supported on this machine.

Always select "FUEL LEVEL".

If "BACKLIGHT DIMMER" is selected, "NO DATA" appears as the value for the fuel level parameter.



# Handling Instructions

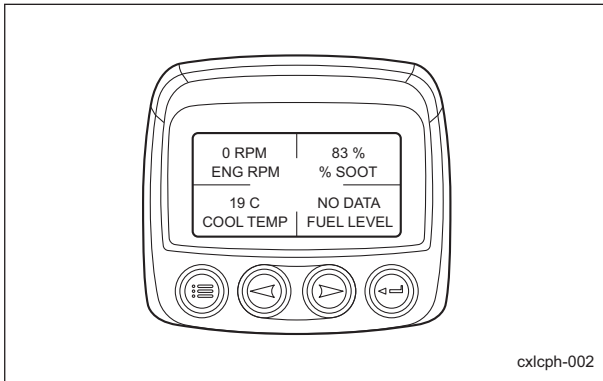

Analog Input\_001

**Note:**

The factory default analog input is "FUEL LEVEL".

**1. Fuel Level**

With "FUEL LEVEL", the low fuel level can be specified.

1. Press the menu key.

After the main menu appears, use the arrow keys to highlight "UTILITIES", and then press the Enter key.

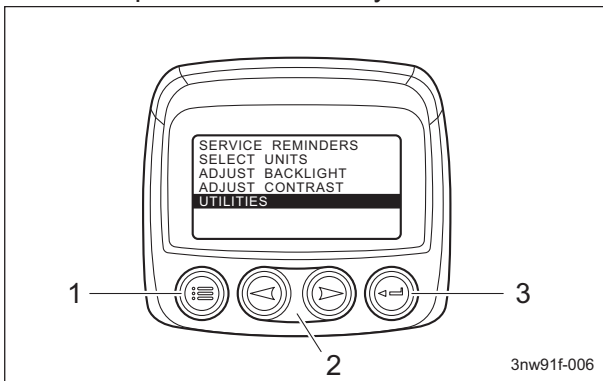

Fuel Level\_001

1	Menu key
2	Arrow keys
3	Enter key

2. Highlight "ANALOG INPUT", and then press the Enter key.

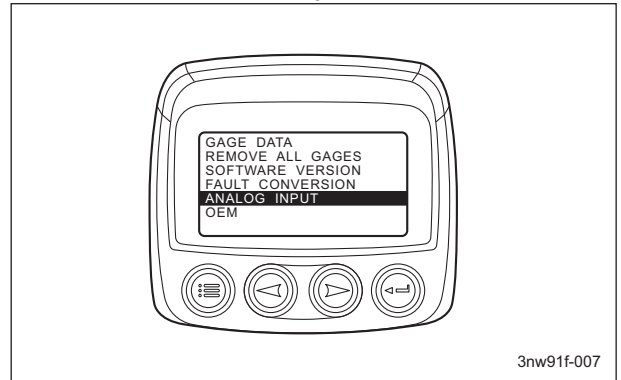

Fuel Level\_002

3. Highlight "FUEL LEVEL", and then press the Enter key.

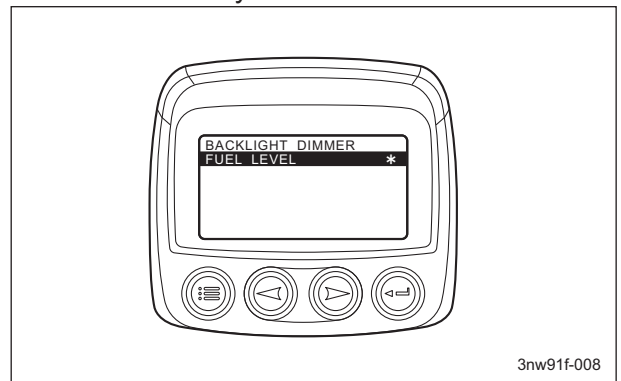

Fuel Level\_003

4. Highlight "SET LOW FUEL LEVEL", and then press the Enter key.

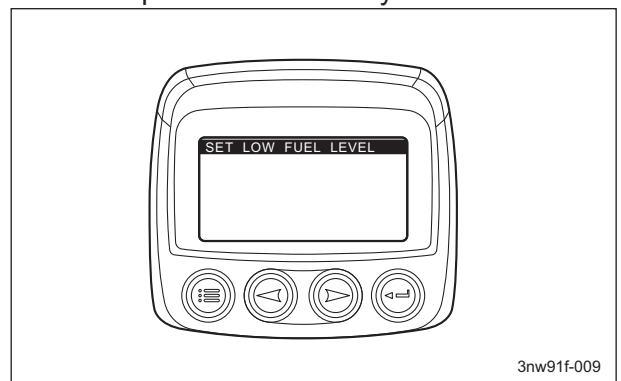

Fuel Level\_004

# Handling Instructions

5. "LOW FUEL" appears.

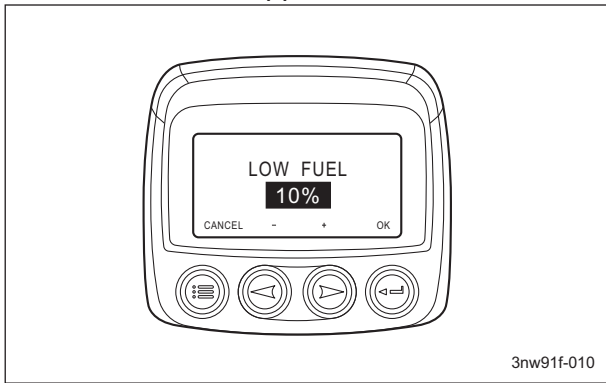

Fuel Level\_005

6. Press the right arrow key to increase the value. Press the left arrow key to decrease the value. The value can be set between 10% and 80% in 5% increments.
7. To save the specified value, press the Enter key.

Note:

The factory default low fuel level is 10%.

## 2. Low Fuel Level Display

### Caution

If a warning message appears, immediately stop operation, and then supply fuel.

1. When the fuel level falls below the specified low fuel level, a warning message appears in the monitor display and the LED (yellow) lights up. The warning message appears on two pages. Use the arrow keys to change the page.
  - Text 1

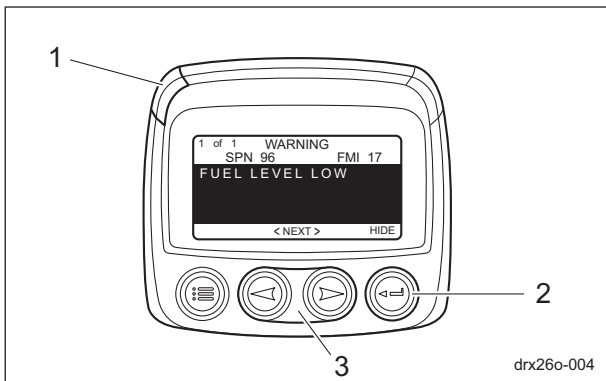

Low Fuel Level Display\_001

1	LED (yellow)
2	Enter key
3	Arrow keys

• Text 2



Low Fuel Level Display\_002

2. Pressing the Enter key changes the screen from the warning message to the parameter display.
3. A warning mark appears in the upper-right corner of the monitor display.

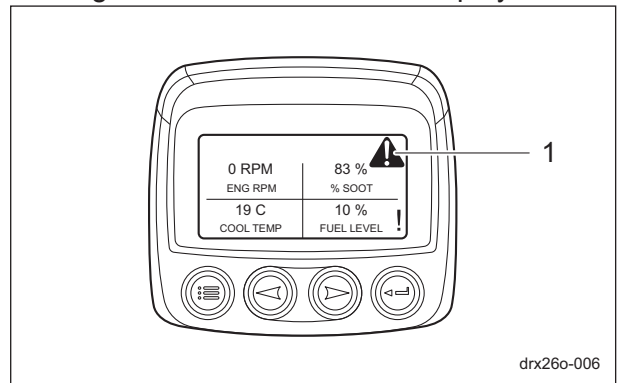

Low Fuel Level Display\_003

1	Warning mark
---	--------------

4. When fuel is supplied to bring the fuel level above the specified low fuel level, the warning message and mark disappear.

### ■ OEM

"OEM" is used when the manufacturer specifies factory default settings.

### Important

No adjustments by the operator are necessary.

# Handling Instructions

## Fault Code Displays

**Important**

When the fault code (DTC) appears in the monitor display, contact your dealer.

A fault code (DTC) appears in the monitor display when a failure occurs on the function of engine.

Each fault code is displayed over two pages. Use the arrow keys to change the page.

- Text 1  
The fault code name appears.

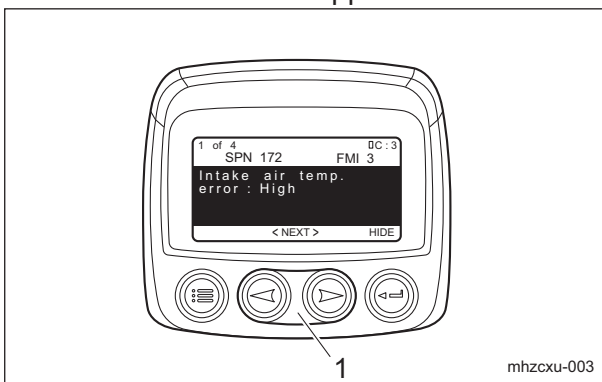

Fault Code Displays\_001

1	Arrow keys
---	------------

- Text 2  
The corrective action appears.

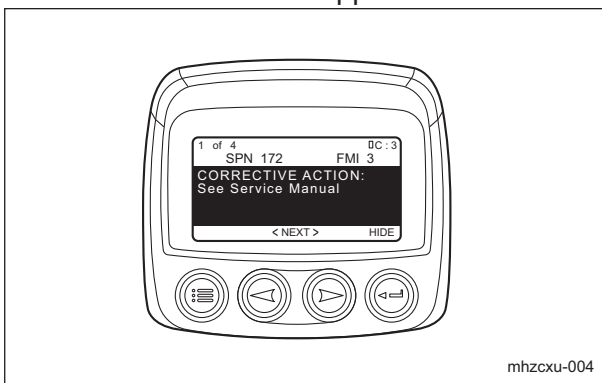

Fault Code Displays\_002

Pressing the Enter key changes the screen from the fault code to the parameter display.

**Important**

If the service reminders are configured, the notices of the replacement time period for consumables and the fault code may appear all together.

If the low fuel level is specified, the notices of fuel level low and the fault code may appear all together.

If "ACTIVE FAULTS - ECU" message appears, check both the service reminder warning message and the fault code (DTC).

To check the service reminder warning message:  
Highlight the service reminder notice, and then press the Enter key.

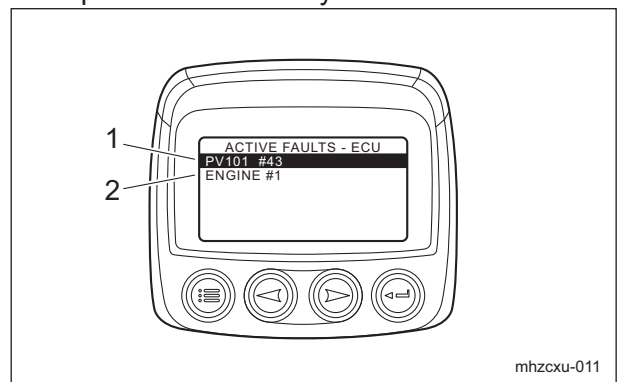

Fault Code Displays\_003

1	Service reminder notice
2	Fault code notice

- Text 1  
The item of requiring replacement of consumables appears.

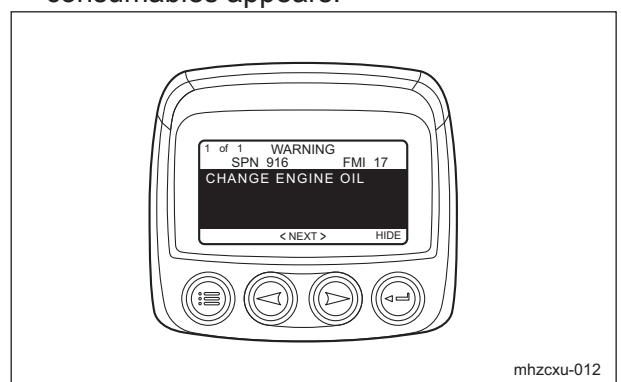

Fault Code Displays\_004

# Handling Instructions

• Text 2

The corrective action appears.

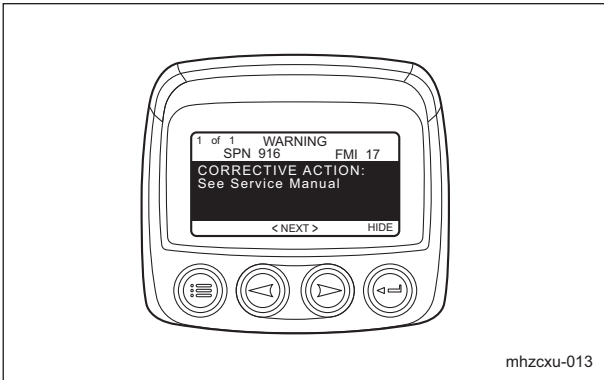

mhzcxu-013

Fault Code Displays\_005

To check the fault code (DTC):  
Highlight the fault code notice, and then press the Enter key.

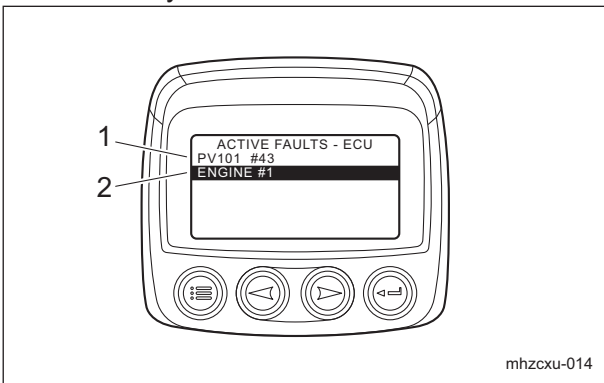

mhzcxu-014

Fault Code Displays\_006

1	Service reminder notice
2	Fault code notice

• Text 1

The fault code (DTC) name appears.

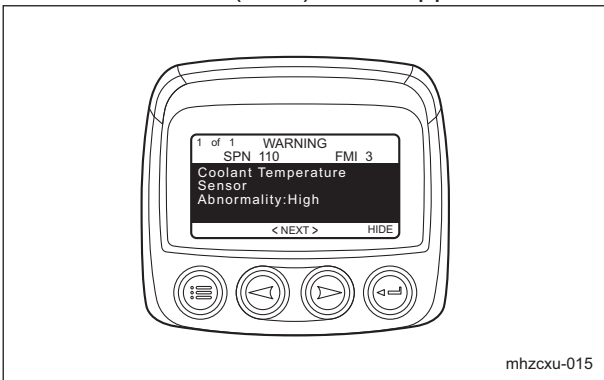

mhzcxu-015

Fault Code Displays\_007

• Text 2

The corrective action appears.

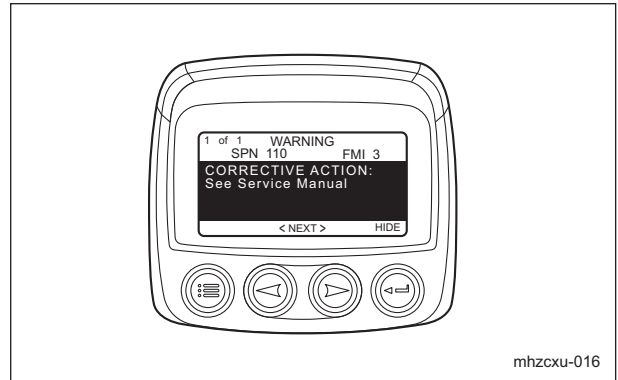

mhzcxu-016

Fault Code Displays\_008

Note:

If the warning message of service reminder ignored and the Enter key pressed to hide the message, the monitor will display "ACTIVE FAULTS - ECU".

If the fault code (DTC) ignored and the Enter key pressed, the monitor will also display "ACTIVE FAULTS - ECU".

If the notice ignored and the menu key pressed when the monitor displays "ACTIVE FAULTS - ECU", the warning mark continues to be displayed in the upper right corner of the monitor display.

To check the warning message and the fault code (DTC) again, press the Enter key to return to the display of "ACTIVE FAULTS - ECU".

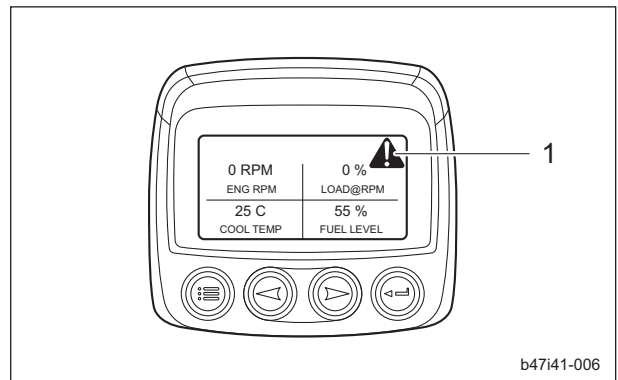

b47i41-006

Fault Code Displays\_009

1	Warning mark
---	--------------

# Handling Instructions

## DPF Regeneration Lamp

1	Engine warning lamp
---	---------------------

**Important**

Do not stop the engine with the DPF regeneration lamp (LED) turned on.

The DPF regeneration lamp (LED) lights up when DPF regeneration starts. The lamp continues lighting up during DPF regeneration and it goes out when the regeneration is completed. The DPF regeneration lamp (LED) blinks when the auto regeneration inhibit switch set to the "Auto regeneration inhibit mode".

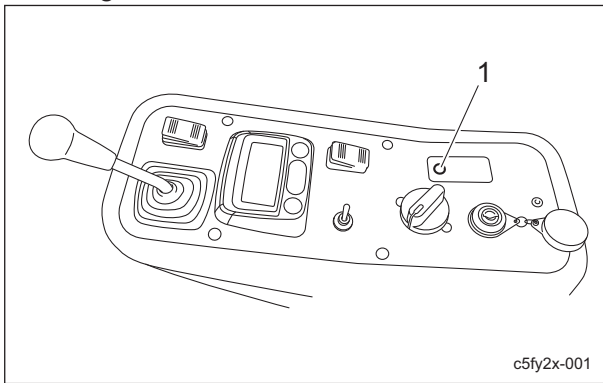

DPF Regeneration Lamp\_001

1	DPF regeneration lamp
---	-----------------------

The lighting patterns of engine warning lamp are as follows.

Note :

PCD means fault codes relevant to Particulate Control Diagnostic.

NCD means fault codes relevant to NOx Control Diagnostic.

1. Engine warning lamp lights up when only DTC other than PCD/NCD come up.

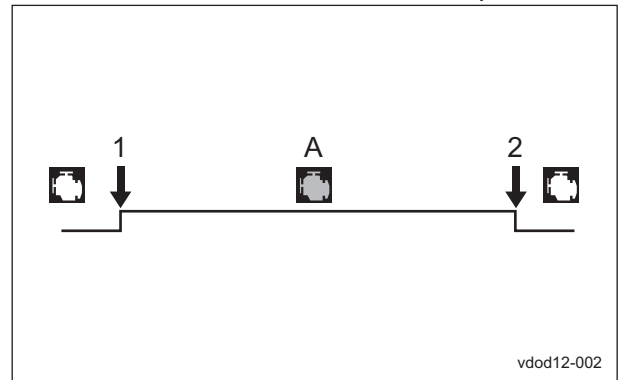

Engine Warning Lamp\_002

1	Fault detected
2	Recovery
A	Lighting

2. Engine warning lamp blinks when only DTC relevant to PCD/NCD come up.

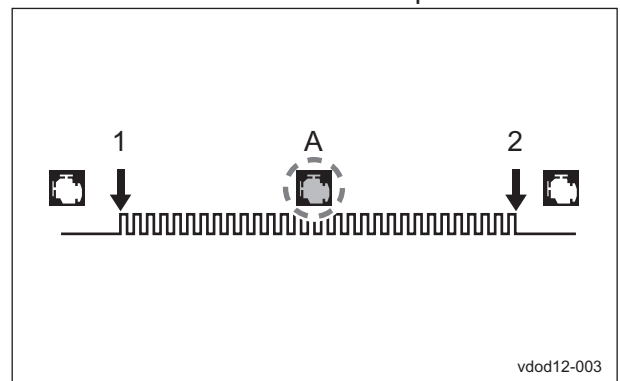

Engine Warning Lamp\_003

1	Fault detected
2	Recovery
A	Blinking

## Engine Warning Lamp

**Important**

Make repairs immediately if the fault codes of PCD (Particulate Control Diagnostic) and NCD (NOx Control Diagnostic) appear.

Engine warning lamp (LED) lights up or blinks when a failure occurs on the function of engine. Check the fault code (DTC) in the monitor display.

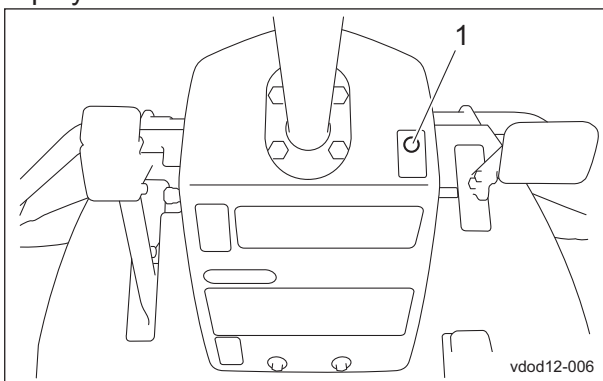

Engine Warning Lamp\_001

# Handling Instructions

3. Engine warning lamp repeats blinking and lighting alternately when DTC relevant to/ other than PCD/NCD come up at the same time. (It repeats blinking three times and lighting three seconds.)

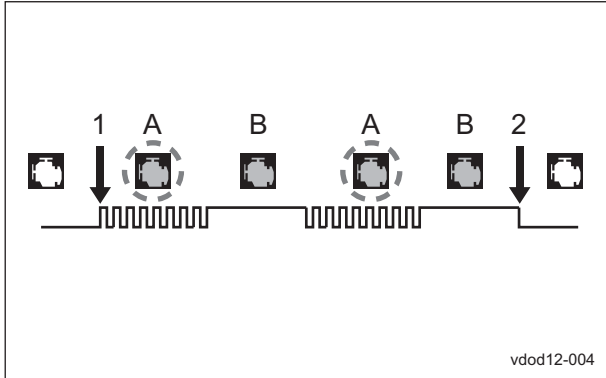

Engine Warning Lamp\_004

1	Fault detected
2	Recovery
A	Blinking
B	Lighting

## Move

### Traveling Procedure

**Caution**

Under any circumstances drive the machine at such a speed that you can stop it immediately for emergencies.

**Caution**

When traveling, be sure to push the reel rotation switch to the "Stop" side and raise the mower units.

**Important**

Do NOT start to move or stop the machine abruptly. It will damage the hydraulic system or result in oil leakage.

1. Start the engine.  
"Procedure to Start Engine" (Page 4-23)
2. Make sure that all mower units are raised and that the mower lock levers (latches) for mower units #4 and #5 are engaged.
3. Firmly depress the brake pedal to release the locking pedal and release the brake pedal.

4. Take your foot off the brake pedal.
5. Slowly depress the traveling pedal.
6. The machine starts traveling.
7. When you take your foot off the traveling pedal, the machine stops slowly.

### Towing The Machine

If the machine does not travel due to engine trouble, etc., you can move it in the following ways:

**Caution**

Do not touch the unload valve except when towing the machine.

**Caution**

Before starting the engine, be sure to close the unload valves.

**Important**

When towing the machine, travel at a speed no more than 3.0 km/h. In addition, do not tow the machine for more than 3 minutes. If the towing speed is too fast or there is excessive movement, the pump or motor will be damaged.

**Important**

Do not loosen the unload valve three turns or more.

1. Stop the engine.  
"Procedure to Stop Engine" (Page 4-24)
2. Depress the locking pedal while firmly depressing the brake pedal to lock it.
3. Chock the wheels.
4. Secure the rope to the tow hook.

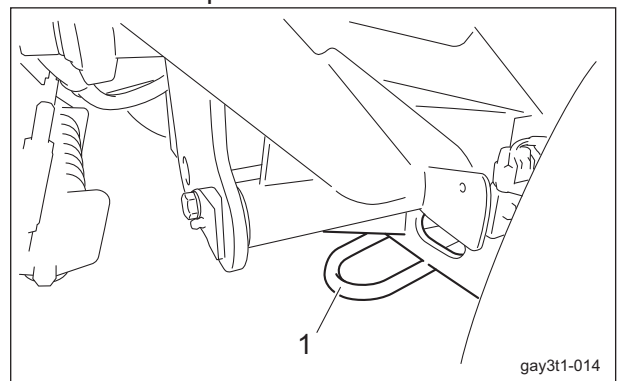

Towing The Machine\_001

# Handling Instructions

1 Tow hook

5. Open the underseat cover.  
"Underseat Cover" (Page 4-40)
6. Turn the unload valve under the seat 1 to 1.5 turns counterclockwise.

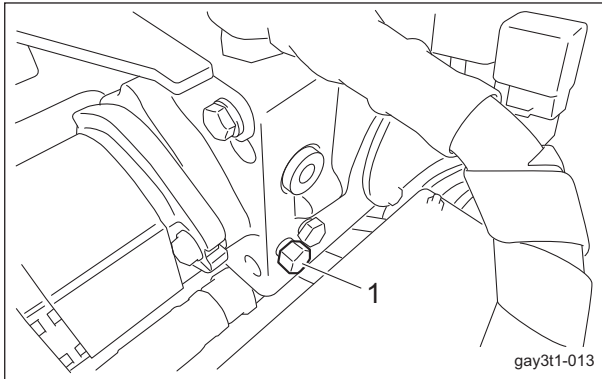

Towing The Machine\_002

1 Unload valve

7. Close the underseat cover.
8. Remove the wheel stoppers.
9. Firmly depress the brake pedal to release the locking pedal.

## Warning

While towing, always keep your foot on the brake pedal and depress the brake pedal at any time to stop.

10. Tow the machine slowly.

## Cutting Work

### Cutting Work

## Caution

Be sure to operate at an appropriate speed for the mowing site.  
When cutting over bumpy surfaces, keep the engine rpm steady, and slow down the cutting speed.

## Caution

Note that if you stop operating the mower unit up/down lever before the mower units are raised completely, reel rotation may not stop. Reel rotation will be turned on or off based on the sensor-detected position of the mower units.

## Caution

After sand topdressing, close the cutter cover. Otherwise, sand may fly out and get in your eyes.

## Important

Mow with the lever shifted to the "Down" position.  
When the lever is returned to the neutral position, the cylinders are fixed, preventing mowing on undulations.

## Important

Do NOT start to move or stop the machine abruptly.  
It will damage the hydraulic system or result in oil leakage.

1. Release the mower lock levers (latches) for mower units #4 and #5 just before cutting work.
2. Start the engine.  
"Procedure to Start Engine" (Page 4-23)
3. Firmly depress the brake pedal to release the locking pedal for releasing the locked brake pedal.
4. Shift the throttle knob to rev the engine up to the maximum rpm.
5. Set the traveling/working selector switch to the "Working" position.
6. Shift the mower unit up/down lever to the "Down" position to lower the mower units.
7. Set the reel rotation switch to the "Rotation" position to rotate the reel cutters (cutting cylinders) of all mower units.

## Important

When the traveling speed exceeds 12.0 km/h during cutting operation, a buzzer will sound. If the operation continues, the engine and hydraulic equipments will be damaged.

8. Set the pedal stopper to the "Working" position.
9. Depress the traveling pedal to start cutting work.

## Note:

During the work, the reel cutters (cutting cylinders) will rotate or stop in sync with the up and down motion of the mower units.

# Handling Instructions

## Removal/Installation of Grass Catcher

**⚠ Caution**

Stop the engine before removing or installing the grass catcher.

1. Set the reel rotation switch to the "Stop" position.
2. Lower the mower units.
3. Apply the parking brake.
4. Stop the engine.
5. Remove or install the grass catcher.
  - Removal of grass catcher:  
Lift up the grass catcher, and remove the mounting pins on the left and right sides of the grass catcher from the grass catcher mounting brackets.
  - Installation of grass catcher:  
Install the mounting pins on the left and right sides of the grass catcher into the grass catcher mounting brackets.

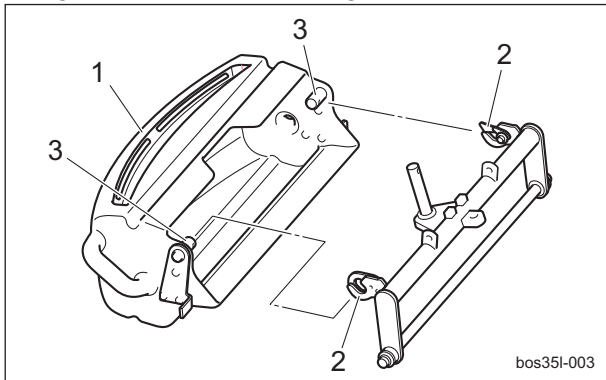

Removal/Installation of Grass Catcher\_001

1	Grass catcher
2	Grass catcher mounting bracket
3	Mounting pin

When tying down the machine, secure the rope at the following locations.  
At the front of the machine, use the tow hooks on the left and right of the front axle.

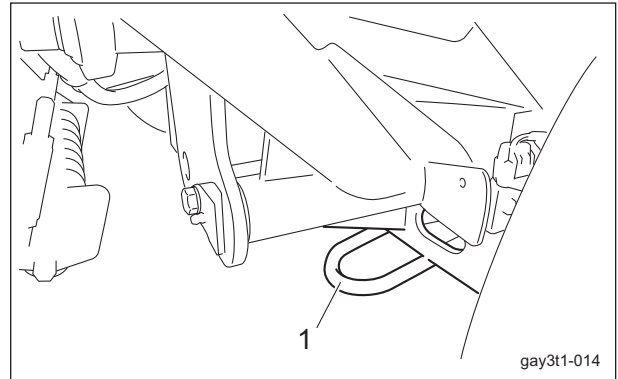

Transporting Procedure\_001

1	Tow hook
---	----------

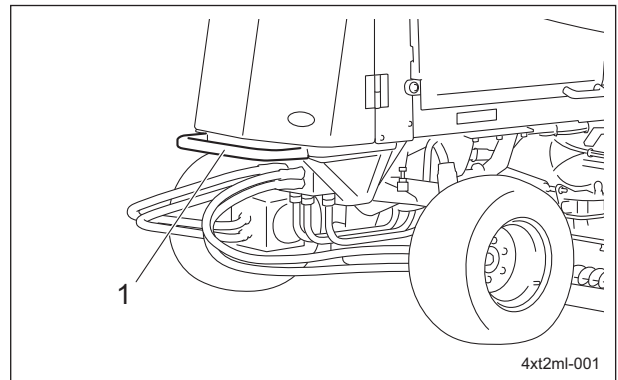

Transporting Procedure\_002

1	Bumper
---	--------

## Storage

### Before Long-Term Storage

1. Cleaning
  - Remove dirt, grass clippings, oil stains etc. completely from the main vehicle and engine.
2. Replacing oil
  - Inspect and replace the engine oil, hydraulic oil and element.
3. Greasing and lubricating
  - Supply oil and apply grease to appropriate parts.
4. Battery
  - Loosen the battery cutoff switch to disconnect the negative battery cable. Switch the ignition key to the "ON" position and check that the charge lamp and oil pressure lamp do not turn on.

## Transporting

### Transporting Procedure

When using a truck or trailer for transporting, drive the machine forward to load it and in reverse to unload it.  
If the roof is installed on the machine, remove it.  
Otherwise, the roof may be damaged by wind pressure.  
Note:



## 5. Fuel

- Remove the fuel from the fuel tank.

## 6. Tire pneumatic pressure

- Set the tire air pressure slightly higher than normal, and then place the machine on a board to avoid humidity.

## 7. Mower units

- When storing this machine, lower all the mower units unless a positive mechanical lock is provided.

## 8. Storage location

- Cover the machine and store it in a dry place where it will not be exposed to rain.

# Handling Instructions

---

<b>Maintenance Precautions</b> .....	<b>Page 5-2</b>	Change of Hydraulic Oil Filter .....	Page 5-48
<b>Maintenance Schedule</b> .....	<b>Page 5-2</b>	Change of Air Cleaner .....	Page 5-50
Adjusted Value .....	Page 5-7	Change of Engine Oil .....	Page 5-50
<b>DPF</b> .....	<b>Page 5-8</b>	Change of Engine Oil Filter .....	Page 5-51
About DPF .....	Page 5-8	Change of Fuel Filter .....	Page 5-52
DPF Regeneration .....	Page 5-8	Change of Fuse .....	Page 5-53
Replacement of DPF .....	Page 5-13		
Conditions for DPF Regeneration .....	Page 5-14		
PM Accumulation Level .....	Page 5-14		
<b>Jacking Up The Machine</b> .....	<b>Page 5-22</b>		
About Jacking Up The Machine .....	Page 5-22		
Jack-Up Points .....	Page 5-22		
<b>Greasing</b> .....	<b>Page 5-24</b>		
About Greasing .....	Page 5-24		
Greasing Points .....	Page 5-24		
<b>Lubrication</b> .....	<b>Page 5-28</b>		
About Lubrication .....	Page 5-28		
Lubricating Points .....	Page 5-28		
<b>Maintenance Work</b> .....	<b>Page 5-30</b>		
Swiveling Mower Units #2 and #3 .....	Page 5-30		
Removing/Installing Tires .....	Page 5-32		
Adjustment of Belt Tension .....	Page 5-33		
Adjustment of Parking Brake .....	Page 5-33		
Adjustment of Brake .....	Page 5-34		
Adjusting The Neutral Position of The Piston Pump .....	Page 5-35		
Adjustment of Control Arm .....	Page 5-36		
Adjustment of Stoppers .....	Page 5-36		
Adjustment of Mower Locking Pin .....	Page 5-37		
Adjustment of Mower Stabilizer .....	Page 5-37		
Adjustment of Stopper Nuts .....	Page 5-38		
Adjustment of Mower Unit Leveling Spring .....	Page 5-38		
Adjustment of Positions of Mower Units #2 and #3 .....	Page 5-40		
Adjustment of Mower Stopper .....	Page 5-41		
Change of Coolant .....	Page 5-45		
Change of Hydraulic Oil .....	Page 5-47		

# Maintenance

## Maintenance Precautions

**Warning**

The chapter "Maintenance" in this manual describes practical measures which should be performed by a mechanic with expertise. The owner should instruct the mechanic with expertise to perform maintenance service for this machine.

**Caution**

First, learn well the maintenance operations you plan to perform.

**Important**

Use tools appropriate for each maintenance operation.

**Important**

For the safe and best performance of your machine, use Baroness genuine parts for replacement and accessories. Please note that our product warranty may be void if you use non-genuine parts for replacement or accessories.

Maintain the machine according to the maintenance schedule so that you will be able to take advantage of its optimum performance for a long period of time.

## Maintenance Schedule

LM551B

Follow the maintenance schedule below.

- . . . Inspect, adjust, supply, clean
- . . . Replace (first time)
- △ . . . Replace

Maintenance Item		Before Work	After Work	Every Week	Every 50 hrs.	Every 100 hrs.	Every 250 hrs.	Every 400 hrs.	Every 500 hrs.	Every 800 hrs.	Every 1500 hrs.	Every 3000 hrs.	Every month	Every year	Every 2 years	Every 4 years	When Required	Remarks
*4	Check fan belt	○																
	Check hydraulic hoses (Moving part)	○																
	Check brake wire	○																

## Maintenance

Maintenance Item		Before Work	After Work	Every Week	Every 50 hrs.	Every 100 hrs.	Every 250 hrs.	Every 400 hrs.	Every 500 hrs.	Every 800 hrs.	Every 1500 hrs.	Every 3000 hrs.	Every month	Every year	Every 2 years	Every 4 years	When Required	Remarks
	Open air cleaner evacuator valve to remove dust		○	○														Open valve every week or daily in dusty conditions
*4	Check fuel hoses and clamp bands				○													
*4	Draining of water separator				○													
	Grease and Lubricate all moving parts				○													
	Check electrical wiring condition (Damage, defacement and joint looseness)				○	○												50 hours first change, every 100 hours thereafter
	Check looseness of wheel mounting bolt				○	○												50 hours first change, every 100 hours thereafter
	Grease mower unit hydraulic motor shafts						○											
*4	Clean air cleaner outer element (Replace the element after 6-time cleaning)					○								△				Replace every 6 cleanings or every year whichever comes earlier Air cleaner should be cleaned more often in dusty conditions than in normal conditions
	Replace hydraulic oil					●		△										100 hours first change, every 500 hours thereafter
	Replace hydraulic suction filter					●		△										100 hours first change, every 500 hours thereafter
	Replace hydraulic oil filter					●		△										100 hours first change, every 500 hours thereafter
*5	Check exterior of battery					○							○					Check every 100 hours or every month whichever comes earlier
*5	Clean exterior of battery					○							○					Check every 100 hours or every month

# Maintenance

Maintenance Item		Before Work	After Work	Every Week	Every 50 hrs.	Every 100 hrs.	Every 250 hrs.	Every 400 hrs.	Every 500 hrs.	Every 800 hrs.	Every 1500 hrs.	Every 3000 hrs.	Every month	Every year	Every 2 years	Every 4 years	When Required	Remarks
*5	Clean exterior of battery					○							○					whichever comes earlier
*5	Check mounting bracket of battery					○							○					Check every 100 hours or every month whichever comes earlier
*5	Check looseness and corrosion of battery terminals					○							○					Check every 100 hours or every month whichever comes earlier
*5	Check battery fluid level					○							○					Check every 100 hours or every month whichever comes earlier
	Check hydraulic hoses (Fixed part)					○							○					Check every 100 hours or every month whichever comes earlier
*4	Check fan belt tension					○												
*4	Check intake air line (air cleaner hose)					○												
*4	Check radiator hoses and clamp bands						○											
*4	Change engine oil				●	△								△				Initial 50 hours, thereafter every 250 hours or every year whichever comes earlier
*4	Replace oil filter cartridge				●		△							△				Initial 50 hours, thereafter every 400 hours or every year whichever comes earlier
*1.*4	Replace fuel filter cartridge						△											
*4	Clean water separator						○											
*2.*4	Clean fuel tank interior							○										
*2.*4	Clean water jacket and radiator interior							○										
*2.*4	Replace fan belt							△						△				Replace every 500 hours or 2 years

## Maintenance

Maintenance Item		Before Work	After Work	Every Week	Every 50 hrs.	Every 100 hrs.	Every 250 hrs.	Every 400 hrs.	Every 500 hrs.	Every 800 hrs.	Every 1500 hrs.	Every 3000 hrs.	Every month	Every year	Every 2 years	Every 4 years	When Required	Remarks
*2.*4	Replace fan belt								△						△			whichever comes earlier
*2.*4	Check valve clearance									○								
*2.*3.*4	Check injection nozzle										○							
*2.*3.*4	Check EGR cooler										○							
*2.*4	Check head cover valve										○							
*2.*3.*4	Check turbocharger											○						
*2.*3.*4	Replace DPF filters											△						
*2.*3.*4	Check EGR system											○						
*2.*4	Replace air cleaner inner element													△				The secondary (inner) element should be removed only if it is to be replaced.
*2.*4	Check DPF-related piping													○				
*2.*4	Check EGR piping													○				
*4	Check intake hose (After air flow sensor)													○				
*4	Check exhaust manifold (Crack, gas leakage and mounting screw)													○				
*2.*4	Replace water hose													△				
*2.*4	Change rubber pipe relating to oil separator														△			
*2.*4	Change rubber pipe relating to DPF (rubber hose of DPF differential pressure sensor)														△			
*2.*4	Replace intake hose (After air flow sensor) and suction air pressure takeout rubber piping														△			

# Maintenance

Maintenance Item		Before Work	After Work	Every Week	Every 50 hrs.	Every 100 hrs.	Every 250 hrs.	Every 400 hrs.	Every 500 hrs.	Every 800 hrs.	Every 1500 hrs.	Every 3000 hrs.	Every month	Every year	Every 2 years	Every 4 years	When Required	Remarks
*2.*4	Replace EGR cooler hose														△			
*2.*4	Replace lubricant hose														△			
*4	Change radiator coolant (L.L.C.)														△			
*2.*4	Replace radiator hoses and clamp bands														△			
*1.*2.*4	Replace fuel hoses and clamps														△			
*2.*4	Replace intake air line (air cleaner hose)														△			
*5	Replace battery														△			
*2	Replace hydraulic hoses (Moving part)														△			
*2	Replace hydraulic hoses (Fixed part)															△		
*2	Replace brake pads																△	
*2	Replace brake cables																△	

- \*1: When biodiesel fuel is used, change the fuel filter cartridge, fuel hose and clamp bands with new ones at intervals half of the usual ones.
- \*2: Consult your local Baroness Dealer or local KUBOTA Dealer for this service.
- The items above (\*3 marked) are registered as emission related critical parts by KUBOTA in the U.S. EPA nonroad emission regulation.  
As the engine owner, you are responsible for the performance of the required maintenance on the engine according to the above instruction.  
Please see the Engine's Warranty Statement in detail.
- The items listed above other than \*3 marked are not necessary to keep the emission-related warranty valid.
- Failure to perform the maintenance will cause problems that will significantly degrade the engine performance.
- \*4: Refer to the Engine's Owner's Manual.
- \*5: Refer to the Battery's Owner's Manual.
- The values for consumables are not guaranteed.
- Replace the steering cylinder hoses every 2 years.



Adjusted Value

Fan belt			10 mm (0.39 in)	Belt slack
Mower stabilizer spring		#1 - 5	140.0 mm (5.51 in)	Total length of spring
Location of stopper nut	LH62	#1, 4, 5	15.0 mm (0.59 in)	
		#2, 3	40.0 mm (1.57 in)	
	LH52	#1, 4, 5	15.0 mm (0.59 in)	
			30.0 mm (1.18 in)	With grass catcher
		#2, 3	40.0 mm (1.57 in)	

# Maintenance

## DPF

### About DPF

The DPF is a purifying filter that collects PM (soot) from exhaust gas.

When a certain amount of PM (soot) has accumulated, DPF regeneration must be performed automatically or manually in order to restore the filtering function.

### DPF Regeneration

#### Danger

Since it will become extremely hot around the exhaust outlet during DPF regeneration, do not perform the regeneration in a location where fires may occur.

#### Caution

Do not use "DPF Auto Regeneration Inhibit Switch" and "DPF Parked Regeneration Switch" during back lapping.

#### Important

When the system enters the level where DPF regeneration is required, perform the regeneration immediately. Interrupting the regeneration or ignoring the warning and continuing traveling or cutting work may cause the engine and DPF to malfunction.

#### Important

Do not repeat unnecessary regeneration or interrupting regeneration. If repeating them, the measured level of engine oil may increase since the engine oil is mixed with a slight amount of fuel, accompanied by quality degradation.

#### Important

Perform DPF regeneration when the engine sufficiently warmed up.

DPF regeneration is burning PM (soot) collected in DPF with the exhaust temperature heated up to high temperature by the engine ECU control of intake air mass and fuel injection.

### Automatic Regeneration

#### Danger

Since it will become extremely hot around the exhaust outlet during DPF regeneration, do not perform the regeneration in a location where fires may occur.

#### Caution

Normally, set the DPF auto regeneration inhibit switch to the "Auto regeneration mode". However, when operating in a location where fires may occur, set the DPF auto regeneration inhibit switch to the "Auto regeneration inhibit mode".

#### Important

When the system enters the level where DPF regeneration is required, perform the regeneration immediately. Interrupting the regeneration can cause the engine and DPF to malfunction.

#### Important

Keep engine rotation at 2200 rpm or more during auto regeneration. When the engine rotation is below 2200 rpm, PM (soot) can not be purified and the auto regeneration will result in failure.

#### Important

If auto regeneration is performed during backlapping operation, the auto regeneration may result in failure. When auto regeneration starts during backlapping operation, stop backlapping immediately and keep auto regeneration activated until it is completed.

Automatic regeneration is the automatic control of increasing the exhaust temperature for DPF regeneration.

- You can continue to use this machine for traveling and cutting work during DPF regeneration.
- You can operate this machine to perform the regeneration. (The fault diagnostic tool is not required.)

- Automatic regeneration is activated only when the auto regeneration inhibit switch set to the "Auto regeneration mode".
- Automatic regeneration is activated when PM accumulation level is "Level 1" or "Level 2".  
However, it may be activated in "Level 0" depending on the other condition.

**Important**

If the regeneration remains uncompleted even after 30 minutes have passed since the start of automatic regeneration in PM accumulation "Level 1", PM accumulation level enters "Level 2".

These are the procedures of automatic regeneration.

■ When the DPF auto regeneration inhibit switch set to the "Auto regeneration mode":

1. When the conditions for automatic regeneration are met, the automatic regeneration starts with the regeneration icon lighting.
2. Set the engine rotation speed to 2,200 rpm or more.
3. When the regeneration completed, the regeneration icon disappears.

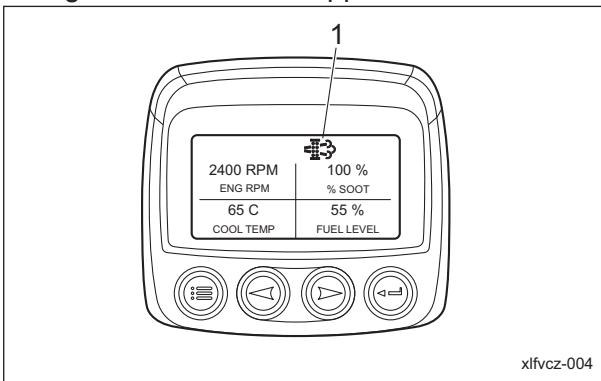

Automatic Regeneration\_001

1	Regeneration icon
---	-------------------

■ When the DPF auto regeneration inhibit switch set to the "Auto regeneration inhibit mode":

1. When PM accumulation level enters "Level 1" or "Level 2", the blinking regeneration icon appears.
2. Set the DPF auto regeneration inhibit switch to the "Auto regeneration".

3. When the conditions for automatic regeneration are met, the automatic regeneration starts and the regeneration icon changes from blinking to lighting.
4. Set the engine rotation speed to 2,200 rpm or more.
5. When the regeneration completed, the regeneration icon disappears.

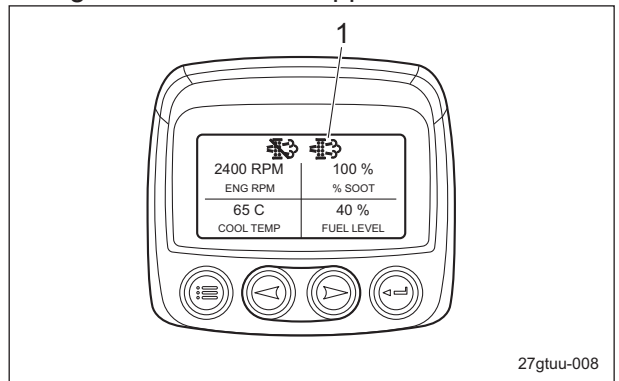

27gtuu-008

Automatic Regeneration\_002

1	Regeneration icon
---	-------------------

# Maintenance

## Parked Regeneration

### **Danger**

Since it will become extremely hot around the exhaust outlet during DPF regeneration, do not perform the regeneration in a location where fires may occur.

### Important

When the system enters the level where DPF regeneration is required, perform the regeneration immediately. Interrupting the regeneration or ignoring the warning and continuing traveling or cutting work may cause the engine and DPF to malfunction.

### Important

Parked regeneration can not be performed as long as the DPF auto regeneration inhibit switch set to the "Auto regeneration inhibit mode". Set it to the "Auto regeneration mode" to perform regeneration.

Parked regeneration is the DPF regeneration forcibly performed, parking this machine in a safe location, when auto regeneration does not reduce the amount of accumulated PM to the specified value.

- You can not continue to use this machine for traveling and cutting work during DPF regeneration.
- You can operate this machine to perform the regeneration. (The fault diagnostic tool is not required.)
- These are the conditions for activating parked regeneration.
  1. The parking brake is applied.
  2. The traveling pedal is in neutral.
  3. The throttle opening is 0% (idling).
- Parked regeneration is activated when PM accumulation level is "Level 1", "Level 2" or "Level 3".

### Important

If the regeneration remains uncompleted in automatic regeneration, parked regeneration is required with the blinking regeneration icon.

### ■ In PM accumulation "Level 1" or "Level 2":

#### Important

If ignoring the parked regeneration requirement and continuing traveling or cutting work in PM accumulation "Level 1" or "Level 2", PM accumulation level enters "Level 2" or "Level 3".

Follow the steps below for parked regeneration.

1. When PM accumulation level enters "Level 1" or "Level 2", the blinking regeneration icon appears. When the DPF auto regeneration inhibit switch set to the "Auto regeneration mode":

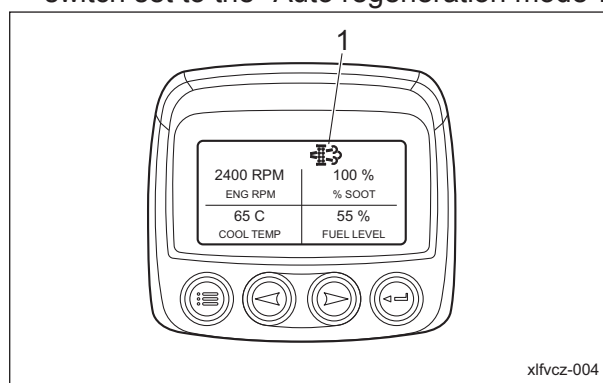

Parked Regeneration\_001

1 | Regeneration icon

When the DPF auto regeneration inhibit switch set to the "Auto regeneration inhibit mode":

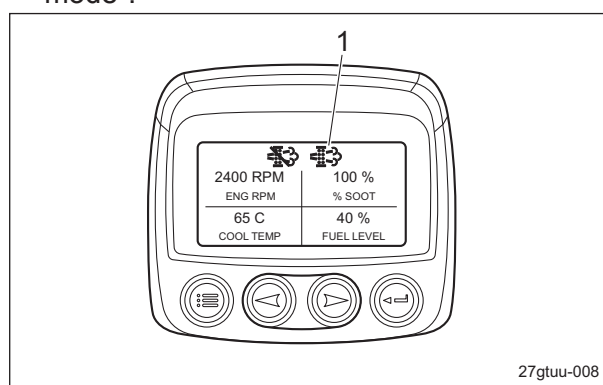

Parked Regeneration\_002

1 | Regeneration icon

2. Stop traveling and cutting work.
3. Park this machine in a safe location.
4. Apply the parking brake.
5. Set the throttle opening to 0% (idling).

6. If the DPF auto regeneration inhibit switch set to the "Auto regeneration inhibit mode," set it to the "Auto regeneration mode."
7. Press the DPF parked regeneration switch. Parked regeneration starts and the regeneration icon changes from blinking to lighting.
8. When the regeneration completed, the regeneration icon disappears.

■ In PM accumulation "Level 3":

**Important**

If ignoring the parked regeneration requirement and continuing traveling or cutting work in PM accumulation "Level 3", PM accumulation level enters "Level 4". If still continuing traveling or cutting work, you will not be able to operate this machine for regeneration.

**Important**

Automatic regeneration can not be activated in PM accumulation "Level 3". Perform parked regeneration immediately.

1. These are the statuses in PM accumulation "Level 3".
  - "Excessive PM3" appears in the monitor display. Pressing an arrow key changes the display to "CORRECTIVE ACTION: Start DPF Parked Regeneration immediately".
  - The LED (yellow) lights up.
  - The engine output is limited at 50%.

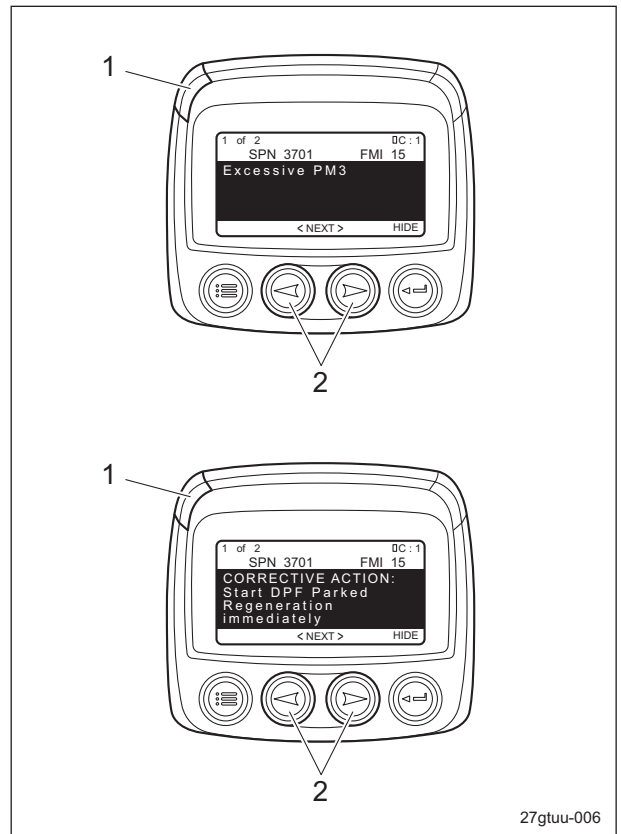

27gtuu-006

Parked Regeneration\_003

1	LED (yellow)
2	Arrow key

2. Stop traveling and cutting work.
3. Park this machine in a safe location.
4. Apply the parking brake.
5. Set the throttle opening to 0% (idling).
6. Press the DPF parked regeneration switch. Parked regeneration starts and the regeneration icon changes from blinking to lighting.
7. When the regeneration completed, the regeneration icon disappears.

# Maintenance

## Manual Regeneration

### **⚠ Danger**

Since it will become extremely hot around the exhaust outlet during DPF regeneration, do not perform the regeneration in a location where fires may occur.

### Important

When the system enters the level where DPF regeneration is required, perform the regeneration immediately. Interrupting the regeneration or ignoring the warning and continuing traveling or cutting work may cause the engine and DPF to malfunction.

### Important

Manual regeneration can not be performed as long as the DPF auto regeneration inhibit switch set to the "Auto regeneration inhibit mode". Set it to the "Auto regeneration mode" to perform regeneration.

Manual regeneration is the DPF regeneration performed only by the expert with the fault diagnostic tool. Normal automatic regeneration or parked regeneration can not complete regeneration since large amount of PM accumulates.

Manual regeneration can be activated in any PM accumulation level.

- You can not continue to use this machine for traveling and cutting work during DPF regeneration.
- You can not perform the regeneration. (The fault diagnostic tool is required.)
- Manual regeneration is activated in PM accumulation "Level 4".
- Manual regeneration is activated in any PM accumulation level when the following condition met.

1. when replacing DPF
2. when replacing ECU

### ■ In PM accumulation "Level 4":

#### Important

If ignoring the manual regeneration requirement and continuing traveling or cutting work in PM accumulation "Level 4", PM accumulation level enters "Level 5". If still continuing traveling or cutting work, fatal trouble will occur on the engine and DPF.

1. These are the statuses in PM accumulation "Level 4".

- "Excessive PM4" appears in the monitor display. Pressing an arrow key changes the display to "CORRECTIVE ACTION: Stop engine!! Contact dealer immediately".
- The LED (yellow) lights up.
- The engine output is limited at 50%.

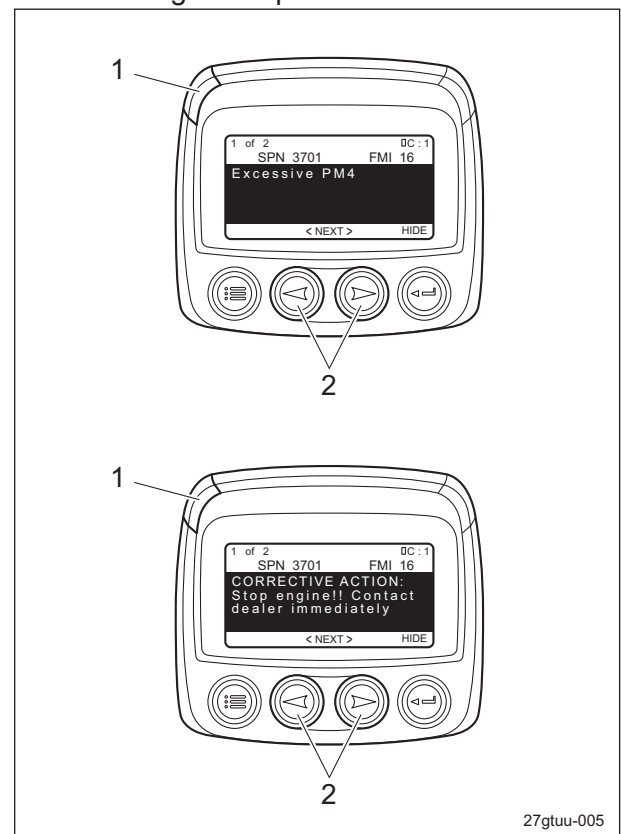

Manual Regeneration\_001

1	LED (yellow)
2	Arrow key

2. Stop traveling and cutting work.
3. Park this machine in a safe location.
4. Apply the parking brake.
5. Stop the engine.

- Contact your dealer for manual regeneration.

## Replacement of DPF

When PM accumulates excessively in the DPF or ash accumulates, replace the DPF since the regeneration in that case is prohibited.

- You can not continue to use this machine for traveling and cutting work.
- The regeneration is impossible.
- Replace every 3,000 hours.
- Replace DPF in PM accumulation "Level 5" or "High frequency of regeneration".

■ In PM accumulation "Level 5":

- These are the statuses in PM accumulation "Level 5".
  - "Excessive PM5" appears in the monitor display. Pressing an arrow key changes the display to "CORRECTIVE ACTION: Stop engine!! Contact dealer immediately".
  - The LED (red) lights up.
  - The engine output is limited at 50%.

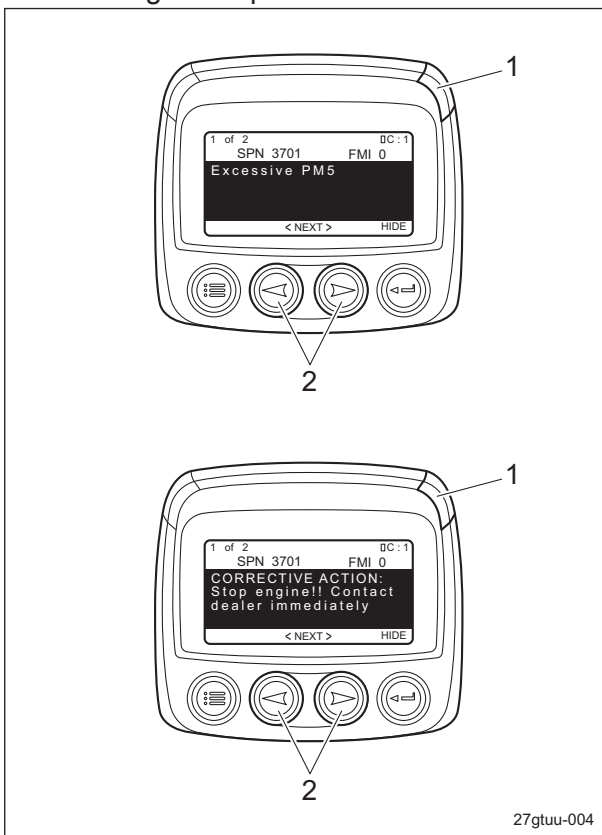

Replacement of DPF\_001

1	LED (red)
2	Arrow key

- Stop traveling and cutting work.

- Park this machine in a safe location.
- Apply the parking brake.
- Stop the engine.
- Contact your dealer for DPF replacement.

■ In the case of "High frequency of regeneration" :

- These are the statuses in the case of "High frequency of regeneration".
  - "High frequency of regeneration" appears in the monitor display. Pressing an arrow key changes the display to description of corrective action.
  - The LED (yellow) lights up.
  - The engine output is limited at 50%.

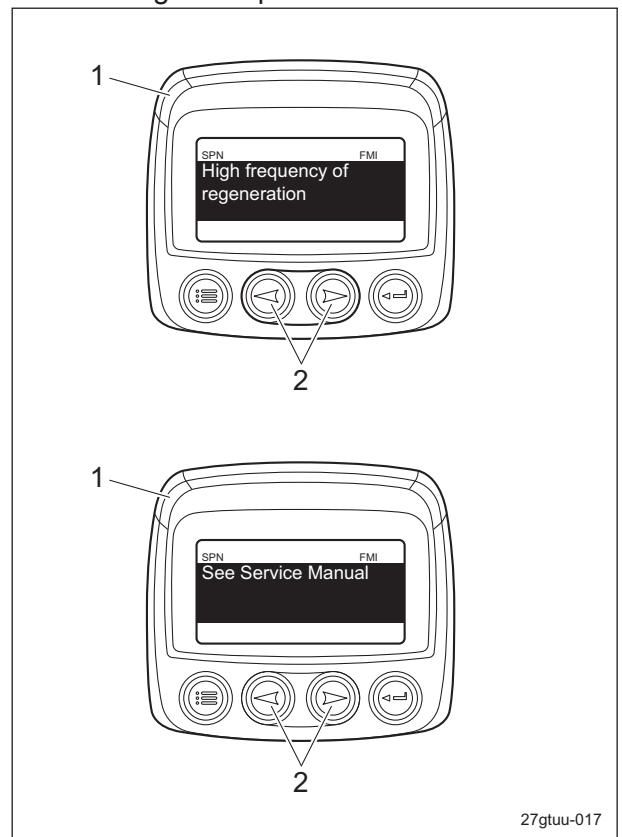

Replacement of DPF\_002

1	LED (yellow)
2	Arrow key

- Stop traveling and cutting work.
- Park this machine in a safe location.
- Apply the parking brake.
- Stop the engine.
- Contact your dealer for DPF replacement.

# Maintenance

## Conditions for DPF Regeneration

### Danger

Since it will become extremely hot around the exhaust outlet during DPF regeneration, do not perform the regeneration in a location where fires may occur.

### Important

If DPF regeneration is interrupted before it is completed, the next regeneration may be requested soon since not all of the PM (soot) was removed.

### Important

Perform DPF regeneration when the engine sufficiently warmed up.

1. DPF auto regeneration does not begin unless both of the following two conditions are met.
  - The DPF auto regeneration inhibit switch is set to the "Auto regeneration mode". (Auto regeneration inhibit icon is turned off.)
  - The coolant temperature is 50 °C or more.
2. DPF parked regeneration and manual regeneration do not begin unless all of the following five conditions are met.
  - The DPF auto regeneration inhibit switch is set to the "Auto regeneration mode". (Auto regeneration inhibit icon is turned off.)
  - The parking brake is applied.
  - The traveling pedal is in the neutral position.
  - The throttle opening is 0% (idling).
  - The coolant temperature is 50 °C or more.
3. During DPF regeneration, the operation is canceled if any of the following conditions occur.
  - Any condition for starting regeneration is violated.
  - The ignition key is switched to the "OFF" position.

## PM Accumulation Level

### Level 0

DPF regeneration is not necessary.

### Level 1

### Danger

Since it will become extremely hot around the exhaust outlet during DPF regeneration, do not perform the regeneration in a location where fires may occur.

### Caution

Normally, set the DPF auto regeneration inhibit switch to the "Auto regeneration mode". However, when operating in a location where fires may occur, set the DPF auto regeneration inhibit switch to the "Auto regeneration inhibit mode".

### Important

When the system enters the level where DPF regeneration is required, perform the regeneration immediately. Interrupting the regeneration or ignoring the warning and continuing traveling or cutting work may cause the engine and DPF to malfunction.

### Important

If the regeneration remains uncompleted even after 30 minutes have passed since the start of automatic regeneration in PM accumulation "Level 1", PM accumulation level enters "Level 2".

### Important

Keep engine rotation at 2200 rpm or more during auto regeneration. If auto regeneration continues at lower engine speed than the specified speed, the engine and DPF will malfunction.



**Important**

When auto regeneration starts during backlapping operation, stop backlapping immediately and keep auto regeneration activated with the engine rotation set to 2200 rpm or more until it is completed.

- You can continue to use this machine for traveling and cutting work during DPF regeneration.
- You cannot continue to use this machine for traveling and cutting work during DPF parked regeneration.
- You can operate this machine to perform the regeneration. (The fault diagnostic tool is not required.)

<Automatic regeneration>

■ When the DPF auto regeneration inhibit switch set to the "Auto regeneration mode":

1. When the conditions for automatic regeneration are met, the automatic regeneration starts with the regeneration icon lighting.
2. Set the engine rotation speed to 2,200 rpm or more.
3. When the regeneration completed, the regeneration icon disappears.

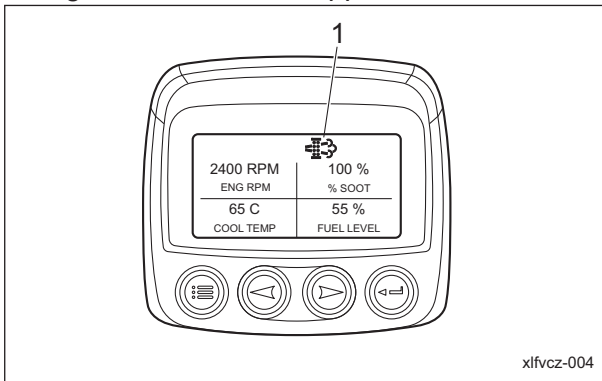

Level 1\_001

1	Regeneration icon
---	-------------------

■ When the DPF auto regeneration inhibit switch set to the "Auto regeneration inhibit mode":

1. The blinking regeneration icon appears.
2. Set the DPF auto regeneration inhibit switch to the "Auto regeneration mode".
3. When the conditions for automatic regeneration are met, the automatic regeneration starts and the regeneration icon changes from blinking to lighting.

4. Set the engine rotation speed to 2,200 rpm or more.
5. When the regeneration completed, the regeneration icon disappears.

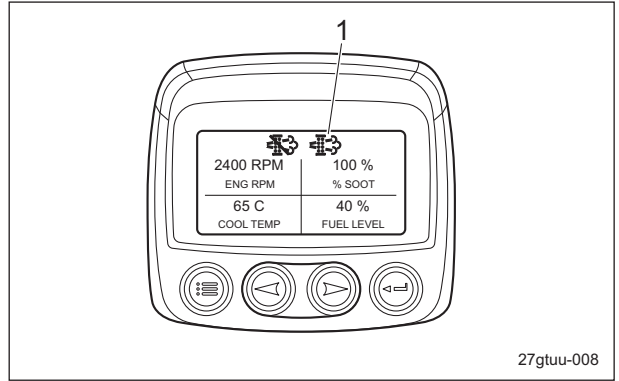

Level 1\_002

1	Regeneration icon
---	-------------------

<Parked regeneration>

- These are the conditions for activating parked regeneration.
  1. The parking brake is applied.
  2. The traveling pedal is in neutral.
  3. The throttle opening is 0% (idling).
  4. The DPF auto regeneration inhibit switch is set to the "Auto regeneration mode". (Auto regeneration inhibit icon is turned off.)

1. The blinking regeneration icon appears. When the DPF auto regeneration inhibit switch set to the "Auto regeneration mode":

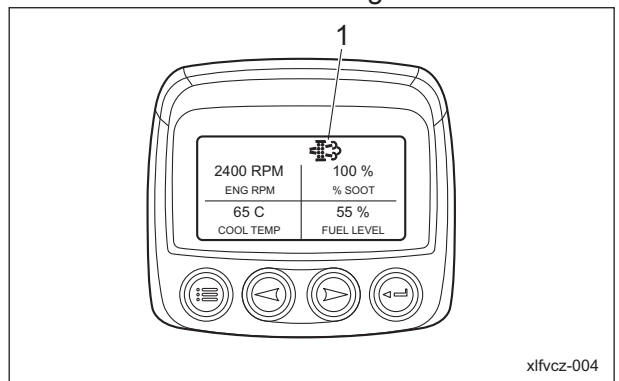

Level 1\_003

1	Regeneration icon
---	-------------------

# Maintenance

When the DPF auto regeneration inhibit switch set to the "Auto regeneration inhibit mode":

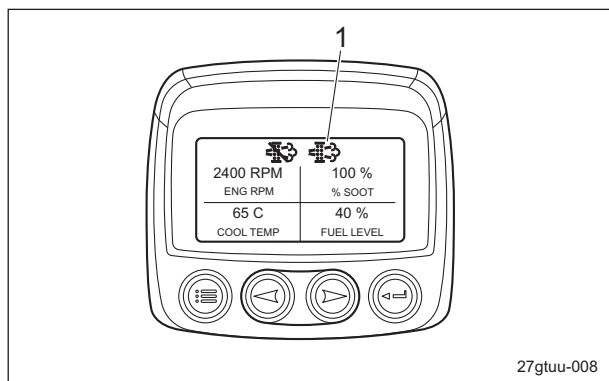

Level 1\_004

1	Regeneration icon
---	-------------------

2. Stop traveling and cutting work.
3. Park this machine in a safe location.
4. Apply the parking brake.
5. Set the throttle opening to 0% (idling).
6. If the DPF auto regeneration inhibit switch set to the "Auto regeneration inhibit mode," set it to the "Auto regeneration mode."
7. Press the DPF parked regeneration switch. Parked regeneration starts and the regeneration icon changes from blinking to lighting.
8. When the regeneration completed, the regeneration icon disappears.

## Level 2

### **! Danger**

Since it will become extremely hot around the exhaust outlet during DPF regeneration, do not perform the regeneration in a location where fires may occur.

### **! Caution**

Normally, set the DPF auto regeneration inhibit switch to the "Auto regeneration mode". However, when operating in a location where fires may occur, set the DPF auto regeneration inhibit switch to the "Auto regeneration inhibit mode".

### Important

When the system enters the level where DPF regeneration is required, perform the regeneration immediately. Interrupting the regeneration or ignoring the warning and continuing traveling or cutting work may cause the engine and DPF to malfunction.

### Important

If ignoring the parked regeneration requirement and continuing traveling or cutting work in PM accumulation "Level 2", PM accumulation level enters "Level 3".

### Important

Keep engine rotation at 2200 rpm or more during auto regeneration. If auto regeneration continues at lower engine speed than the specified speed, the engine and DPF will malfunction.

### Important

When auto regeneration starts during backlapping operation, stop backlapping immediately and keep auto regeneration activated with the engine rotation set to 2200 rpm or more until it is completed.

- You can continue to use this machine for traveling and cutting work during DPF auto regeneration.

- You can not continue to use this machine for traveling and cutting work during DPF parked regeneration.
- You can operate this machine to perform the regeneration. (The fault diagnostic tool is not required.)

#### <Automatic regeneration>

■ When the DPF auto regeneration inhibit switch set to the "Auto regeneration mode":

1. When the conditions for automatic regeneration are met, the automatic regeneration starts with the regeneration icon lighting.
2. Set the engine rotation speed to 2,200 rpm or more.
3. When the regeneration completed, the regeneration icon disappears.

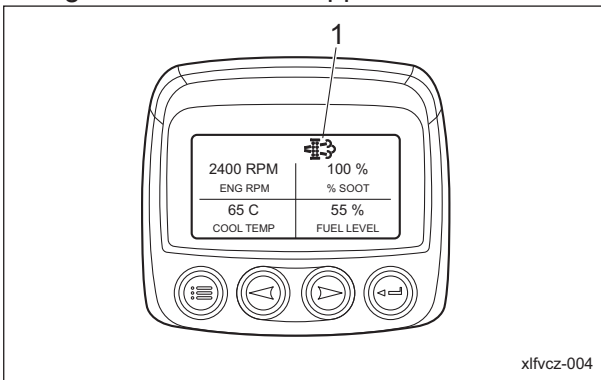

Level 2\_001

1	Regeneration icon
---	-------------------

■ When the DPF auto regeneration inhibit switch set to the "Auto regeneration inhibit mode":

1. The blinking regeneration icon appears.
2. Set the DPF auto regeneration inhibit switch to the "Auto regeneration mode".
3. When the conditions for automatic regeneration are met, the automatic regeneration starts and the regeneration icon changes from blinking to lighting.
4. Set the engine rotation speed to 2,200 rpm or more.
5. When the regeneration completed, the regeneration icon disappears.

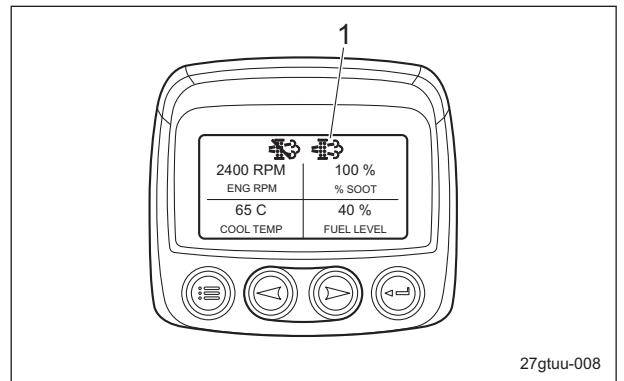

Level 2\_002

1	Regeneration icon
---	-------------------

# Maintenance

## <Parked regeneration>

- These are the conditions for activating parked regeneration.
  1. The parking brake is applied.
  2. The traveling pedal is in neutral.
  3. The throttle opening is 0% (idling).
  4. The DPF auto regeneration inhibit switch is set to the "Auto regeneration mode".  
(Auto regeneration inhibit icon is turned off.)

1. The blinking regeneration icon appears.  
When the DPF auto regeneration inhibit switch set to the "Auto regeneration mode":

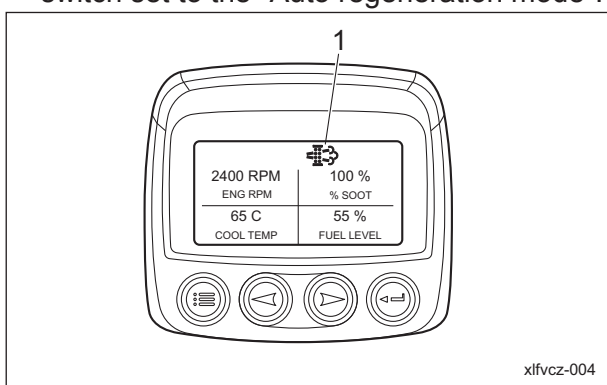

Level 2\_003

1	Regeneration icon
---	-------------------

When the DPF auto regeneration inhibit switch set to the "Auto regeneration inhibit mode":

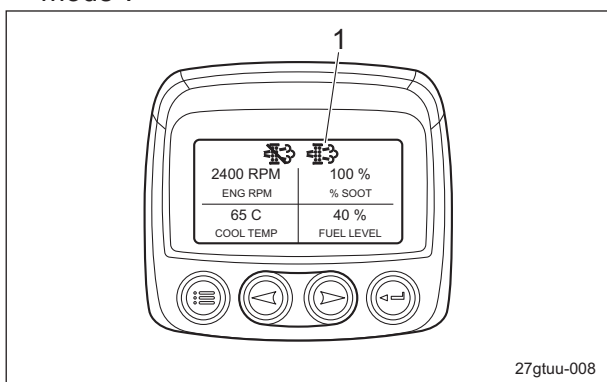

Level 2\_004

1	Regeneration icon
---	-------------------

2. Stop traveling and cutting work.
3. Park this machine in a safe location.
4. Apply the parking brake.
5. Set the throttle opening to 0% (idling).
6. If the DPF auto regeneration inhibit switch set to the "Auto regeneration inhibit mode," set it to the "Auto regeneration mode."

7. Press the DPF parked regeneration switch.  
Parked regeneration starts and the regeneration icon changes from blinking to lighting.
8. When the regeneration completed, the regeneration icon disappears.

## Level 3

### **Danger**

Since it will become extremely hot around the exhaust outlet during DPF regeneration, do not perform the regeneration in a location where fires may occur.

### Important

When the system enters the level where DPF regeneration is required, perform the regeneration immediately. Interrupting the regeneration or ignoring the warning and continuing traveling or cutting work may cause the engine and DPF to malfunction.

### Important

If ignoring the parked regeneration requirement and continuing traveling or cutting work in PM accumulation "Level 3", PM accumulation level enters "Level 4". If still continuing traveling or cutting work, you will not be able to operate this machine for regeneration.

### Important

Automatic regeneration can not be activated in PM accumulation "Level 3". Perform parked regeneration immediately.

- You can not continue to use this machine for traveling and cutting work during DPF regeneration.
- You can operate this machine to perform the regeneration. (The fault diagnostic tool is not required.)

1. These are the statuses in PM accumulation "Level 3".

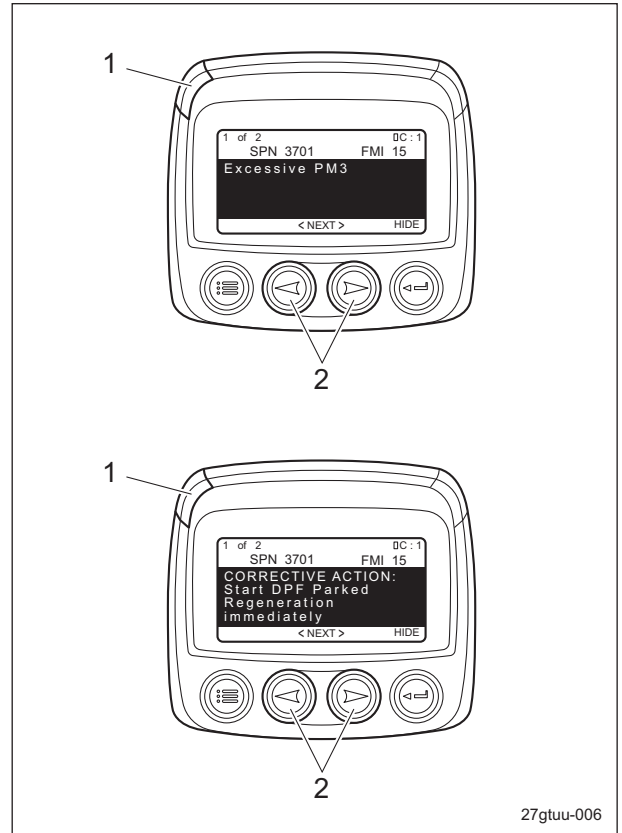

Level 3\_001

1	LED (yellow)
2	Arrow key

- "Excessive PM3" appears in the monitor display. Pressing an arrow key changes the display to "CORRECTIVE ACTION: Start DPF Parked Regeneration immediately".
  - The LED (yellow) lights up.
  - The engine output is limited at 50%.
2. Stop traveling and cutting work.
  3. Park this machine in a safe location.
  4. Apply the parking brake.
  5. Set the throttle opening to 0% (idling).
  6. If the DPF auto regeneration inhibit switch set to the "Auto regeneration inhibit mode," set it to the "Auto regeneration mode."
  7. Press the DPF parked regeneration switch. Parked regeneration starts and the regeneration icon changes from blinking to lighting.
  8. When the regeneration completed, the regeneration icon disappears.

# Maintenance

## Level 4

### **Danger**

Since it will become extremely hot around the exhaust outlet during DPF regeneration, do not perform the regeneration in a location where fires may occur.

### Important

When the system enters the level where DPF regeneration is required, perform the regeneration immediately. Interrupting the regeneration or ignoring the warning and continuing traveling or cutting work may cause the engine and DPF to malfunction.

### Important

If ignoring the manual regeneration requirement and continuing traveling or cutting work in PM accumulation "Level 4", PM accumulation level enters "Level 5". If still continuing traveling or cutting work, fatal trouble will occur on the engine and DPF.

- You can not continue to use this machine for traveling and cutting work during DPF regeneration.
  - You can not perform the regeneration. (The fault diagnostic tool is required.)
1. These are the statuses in PM accumulation "Level 4".

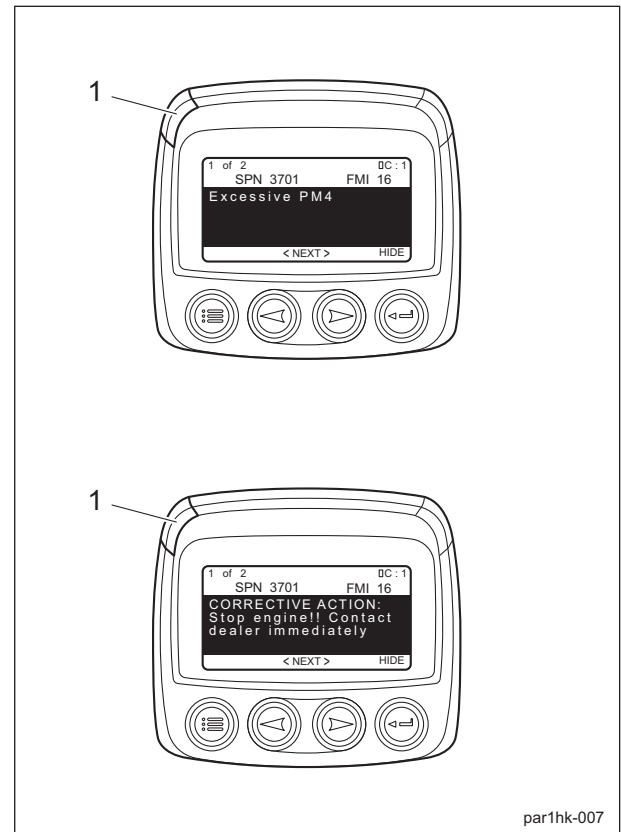

par1hk-007

Level 4\_001

1	LED (yellow)
2	Arrow key

- "Excessive PM4" appears in the monitor display. Pressing an arrow key changes the display to "CORRECTIVE ACTION: Stop engine!! Contact dealer immediately".
  - The LED (yellow) lights up.
  - The engine output is limited at 50%.
2. Stop traveling and cutting work.
  3. Park this machine in a safe location.
  4. Apply the parking brake.
  5. Stop the engine.
  6. Contact your dealer for manual regeneration.

## Level 5

When PM accumulates excessively in the DPF or ash accumulates, replace the DPF since the regeneration in that case is prohibited.

- You can not continue to use this machine for traveling and cutting work.
  - The regeneration is impossible.
1. These are the statuses in PM accumulation "Level 5".

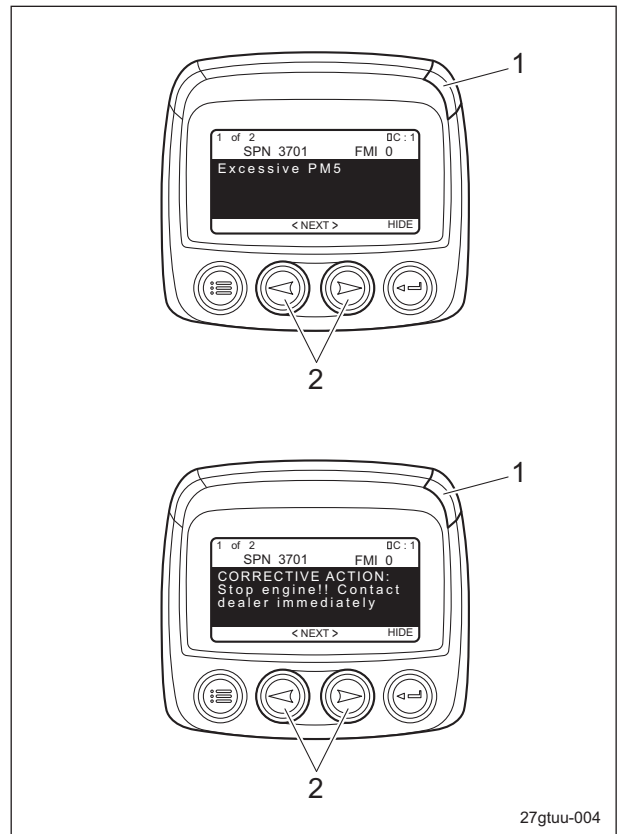

Level 5\_001

1	LED (red)
2	Arrow key

- "Excessive PM5" appears in the monitor display.  
Pressing an arrow key changes the display to "CORRECTIVE ACTION: Stop engine!! Contact dealer immediately".
  - The LED (red) lights up.
  - The engine output is limited at 50%.
2. Stop traveling and cutting work.
  3. Park this machine in a safe location.
  4. Apply the parking brake.
  5. Stop the engine.
  6. Contact your dealer for DPF replacement.

# Maintenance

## Jacking Up The Machine

### About Jacking Up The Machine

**Warning**

When replacing a tire or beginning any other maintenance or repairs, be sure to chock the wheels to prevent the machine from moving. Before jacking up the machine, park it on a hard, flat surface such as a concrete floor and remove any obstacles that could prevent you from performing the work safely. When necessary, use an appropriate chain block, hoist, or jack. Support the machine securely with jack stands or appropriate blocks. Failure to do so may cause the machine to move or fall, resulting in injury or death.

**Important**

Only place a jack under the jack-up points specified. Placing a jack at any other point will result in damage to the frame or other parts.

Use the jack-up points identified in this manual when jacking up the machine.

### Jack-Up Points

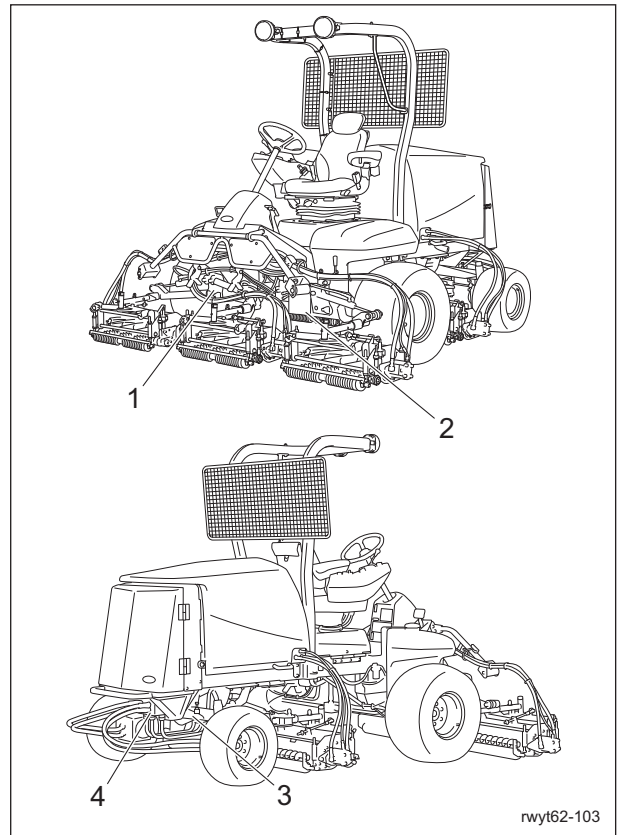

Jack-Up Points\_001

	Jack-up points
1	Front right frame
2	Front left frame
3	Right pivot
4	Left pivot

#### 1. Front right frame

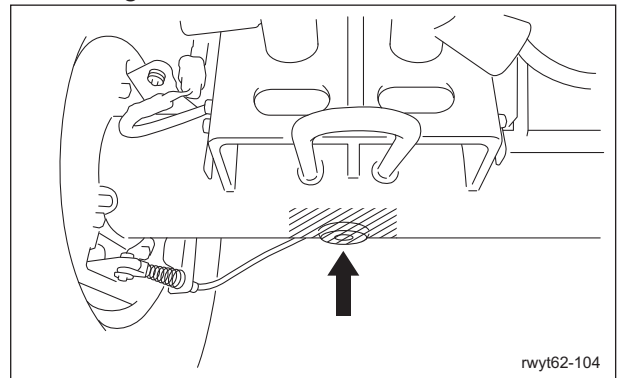

Jack-Up Points\_002



## 2. Front left frame

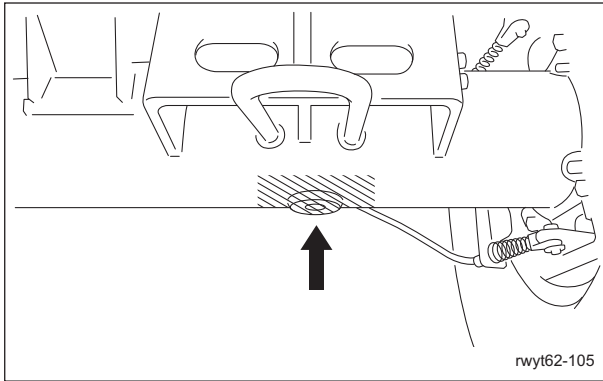

Jack-Up Points\_003

## 4. Left pivot

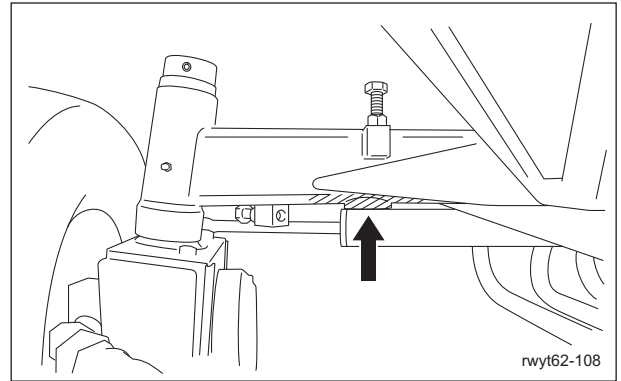

Jack-Up Points\_006

## 3. Right pivot

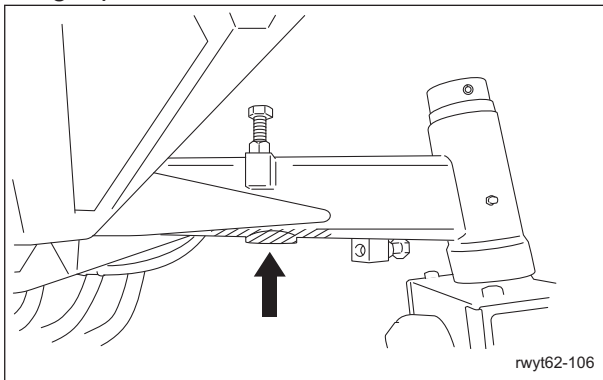

Jack-Up Points\_004

When jacking up the machine at the right pivot, place a block of wood between the right pivot and the frame.

**Note:**

Use a block of wood with a height of approximately 130 mm (5.12 in).

When jacking up the machine at the left pivot, place a block of wood between the left pivot and the frame.

**Note:**

Use a block of wood with a height of approximately 130 mm (5.12 in).

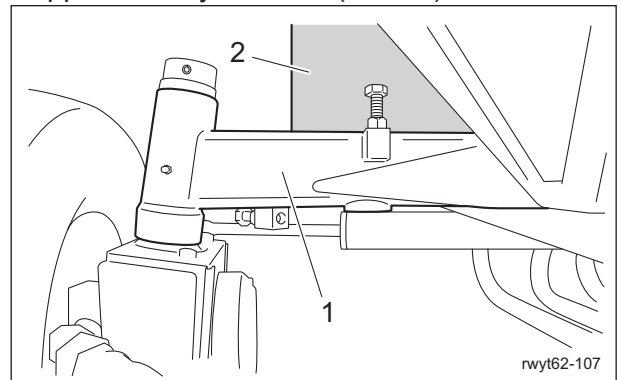

Jack-Up Points\_007

1	Pivot
2	Block of wood

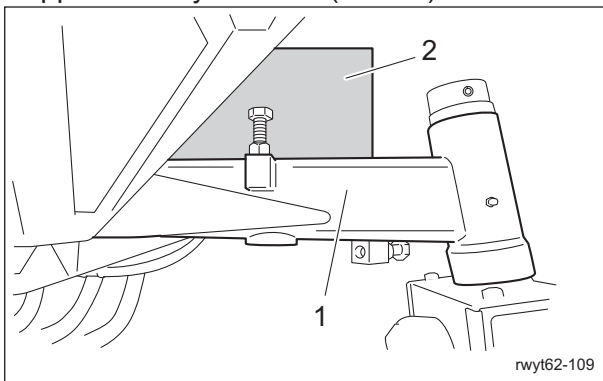

Jack-Up Points\_005

1	Pivot
2	Block of wood

# Maintenance

## Greasing

### About Greasing

Since there may be adhesion or damage due to lack of grease on moving parts, they must be greased.

Add urea-based No. 2 grease in accordance with the Maintenance Schedule.

Other locations where the specified grease or lubricant is used are indicated in "Greasing Points".

Add grease using the specified grease or lubricant.

### Greasing Points

Grease nipples are installed in the following locations.

Add grease every 50 hours of operation.

If specified locations, periods and grease are additionally described below, follow the instructions.

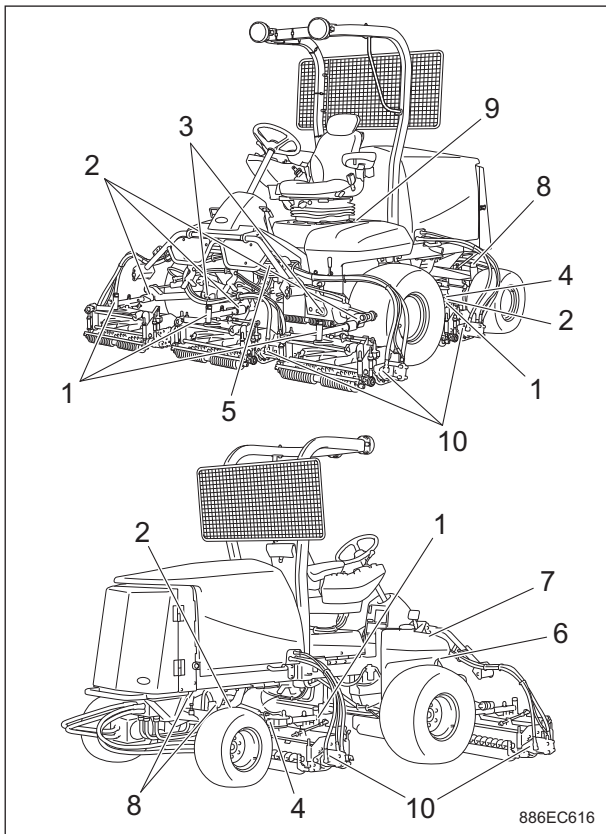

Greasing Points\_001

	Location	No. of greasing points
1	Mower arm fulcrum	5
2	Lift arm fulcrum	5
3	Lift arm fulcrum shaft	3
4	Swiveling bracket fulcrum	2
5	Brake pedal shaft fulcrum	1
6	Traveling pedal shaft fulcrum	1
7	Pedal stopper	1
8	Pivot	3
9	Joint	1
10	Reel motor shaft	5

#### 1. Mower arm fulcrum

There is one greasing point on each mower arm fulcrum.

##### Mower unit #1

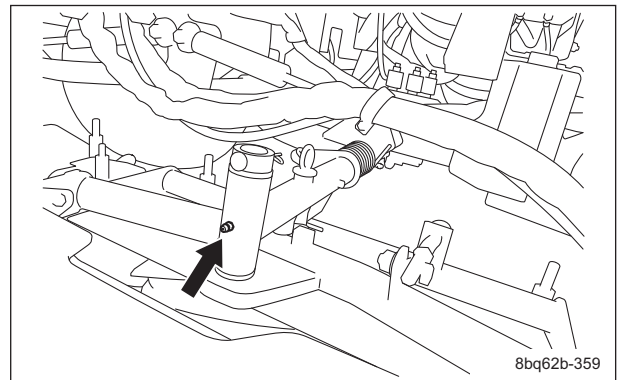

Greasing Points\_002

##### Mower unit #2

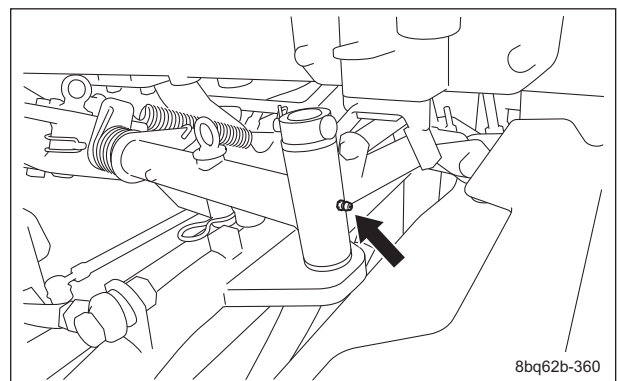

Greasing Points\_003

Mower unit #3

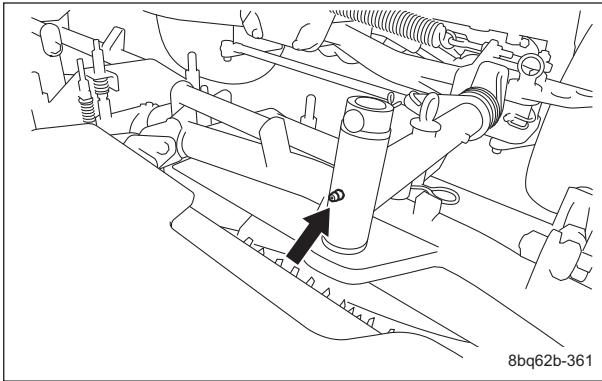

Greasing Points\_004

Mower unit #4

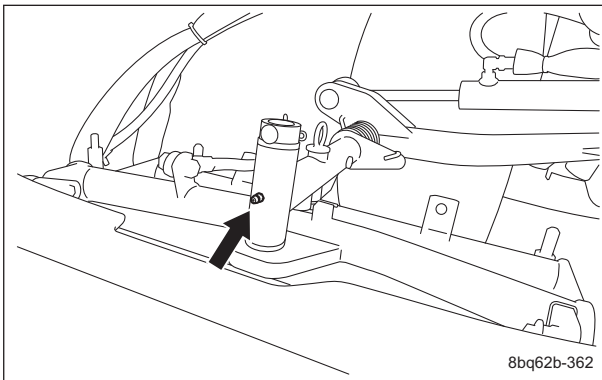

Greasing Points\_005

Mower unit #5

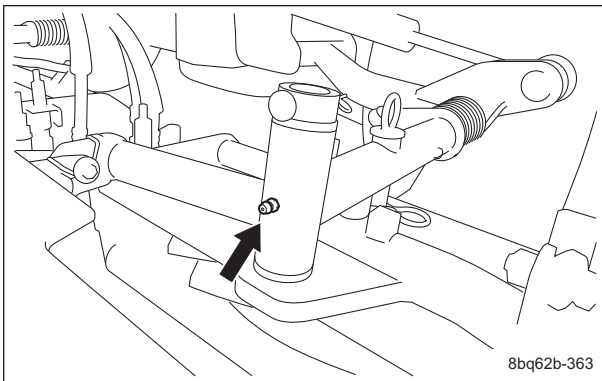

Greasing Points\_006

## 2. Lift arm fulcrum

There is one greasing point on each lift arm fulcrum connected to the mower unit.

Mower unit #1

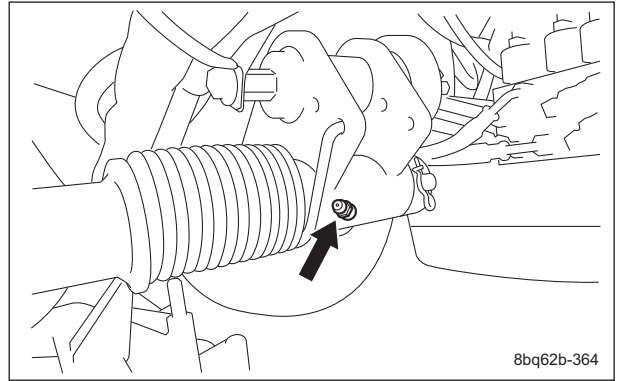

Greasing Points\_007

Mower unit #2

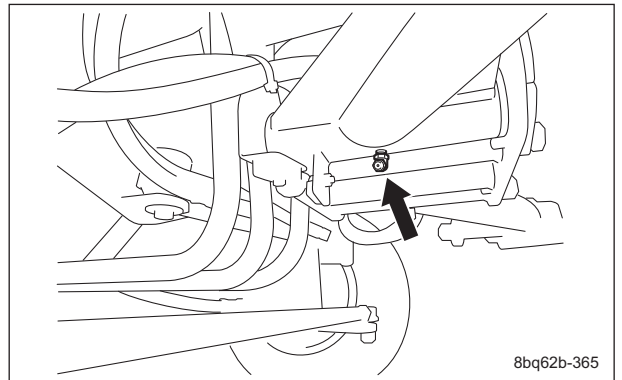

Greasing Points\_008

Mower unit #3

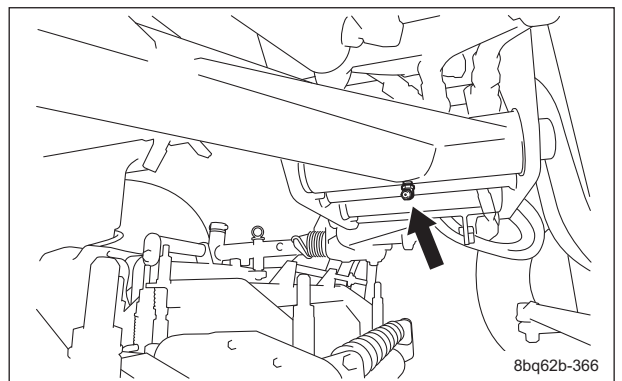

Greasing Points\_009

# Maintenance

Mower unit #4

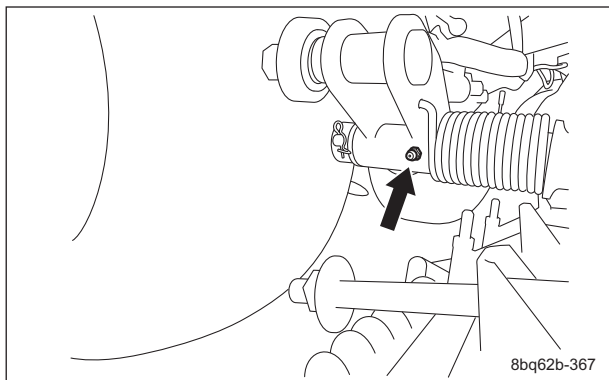

Greasing Points\_010

Mower unit #5

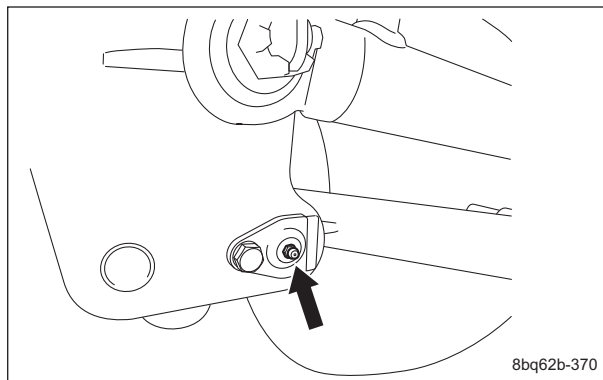

Greasing Points\_013

Mower unit #5

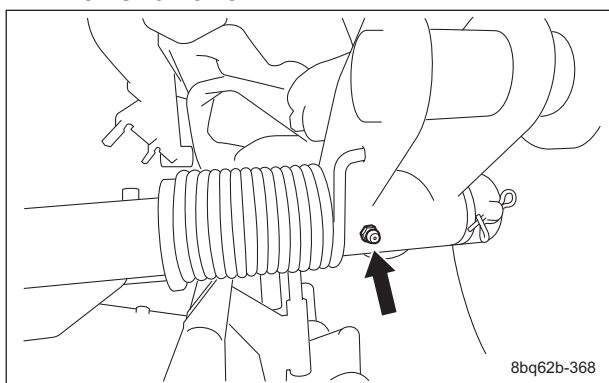

Greasing Points\_011

### 4. Swiveling bracket fulcrum

There is one greasing point on each swiveling bracket fulcrum connected to the mower unit.

Mower unit #2

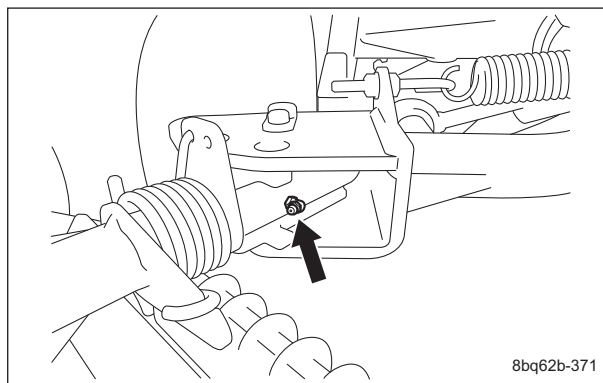

Greasing Points\_014

### 3. Lift arm fulcrum shaft

There is one greasing point on each lift arm fulcrum shaft connected to the mower unit.

Mower units #1 and #4

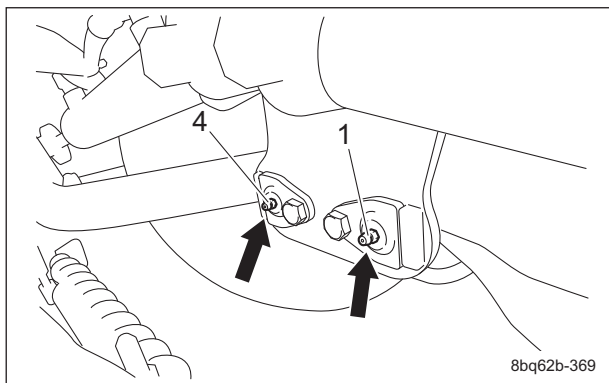

Greasing Points\_012

1	Mower unit #1
2	Mower unit #4

Mower unit #3

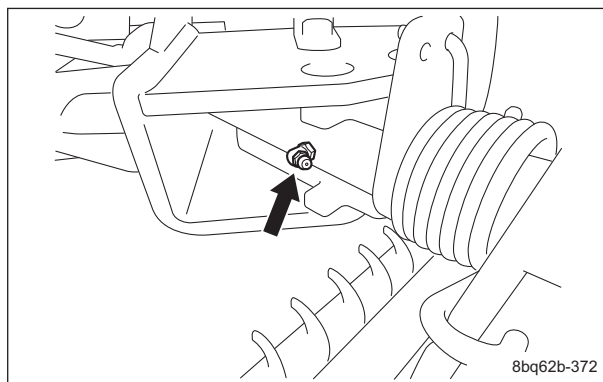

Greasing Points\_015

## 5. Brake pedal shaft fulcrum

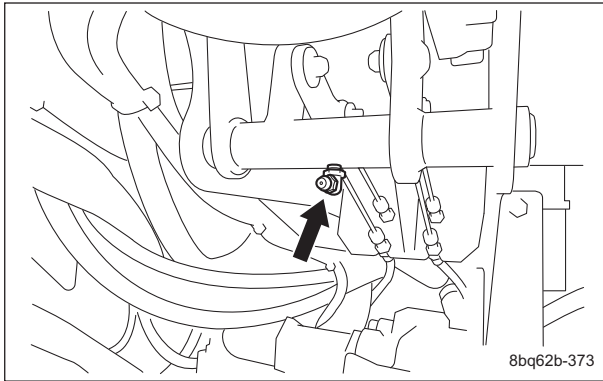

Greasing Points\_016

## Rear wheel Left

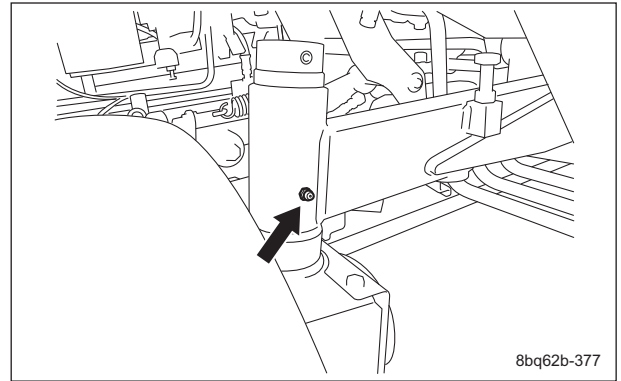

Greasing Points\_020

## 6. Traveling pedal shaft fulcrum

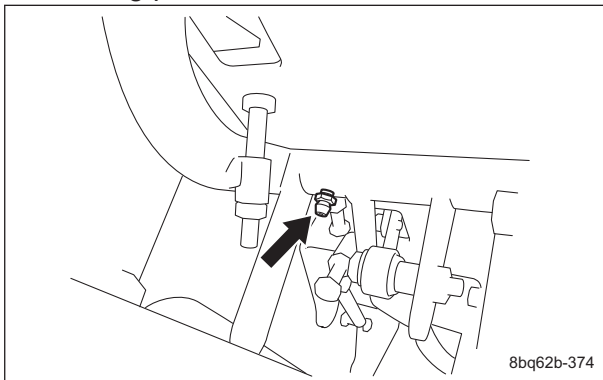

Greasing Points\_017

## Rear wheel Right

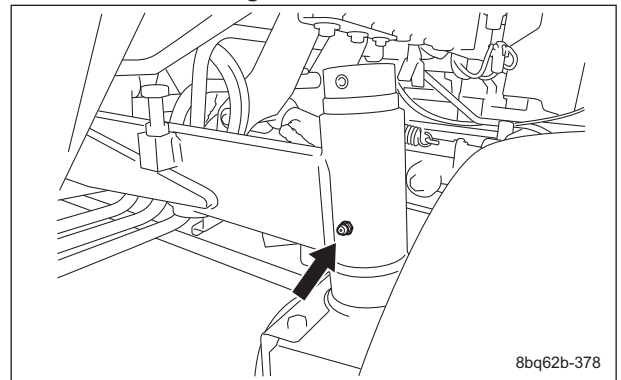

Greasing Points\_021

## 7. Pedal stopper

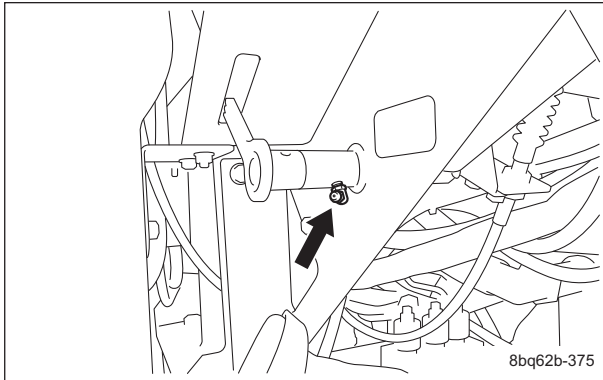

Greasing Points\_018

## 9. Joint

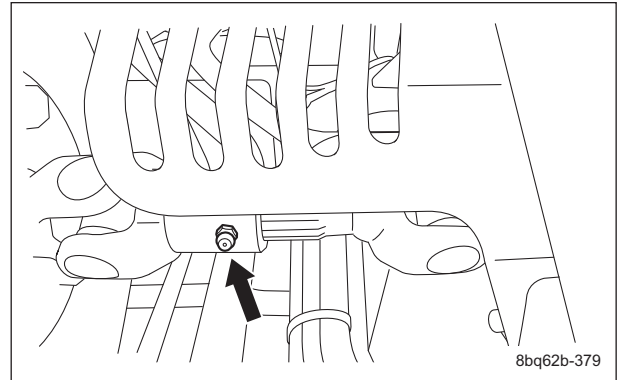

Greasing Points\_022

## 8. Pivot

### Rear wheel Middle

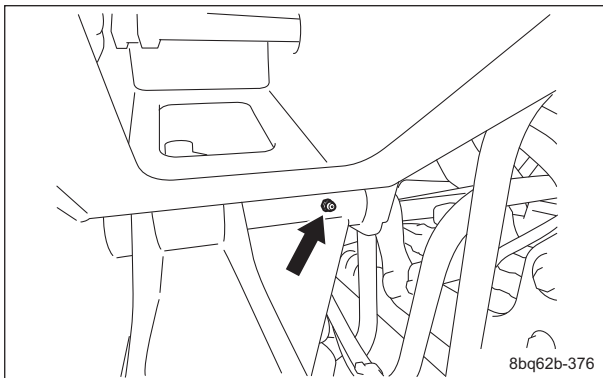

Greasing Points\_019

# Maintenance

## 10. Reel motor shaft

Apply 2 g (0.004 lb) of MORI SPEED GREASE NO.2 to the reel mower shaft mounted on each mower unit every 250 hours.

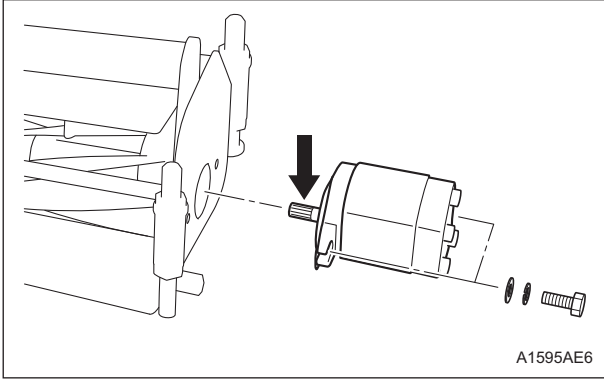

Greasing Points\_023

## Lubrication

### About Lubrication

It is necessary to lubricate moving parts so that they will not become stuck or damaged. The locations where lubricant is used are indicated in "Lubricating Points". Apply the lubricant.

## Lubricating Points

Apply lubricant at the following locations every 50 hours of operation.

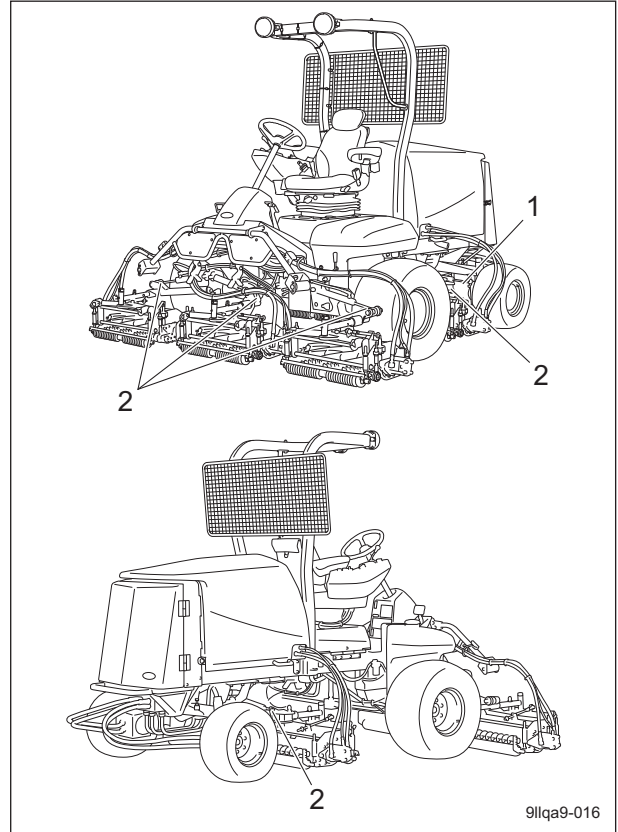

Lubricating Points\_001

	Location	No. of greasing points
1	Steering cylinder spherical bearing	2
2	Mower cylinder spherical bearing	10

### 1. Steering cylinder spherical bearing There are two locations.

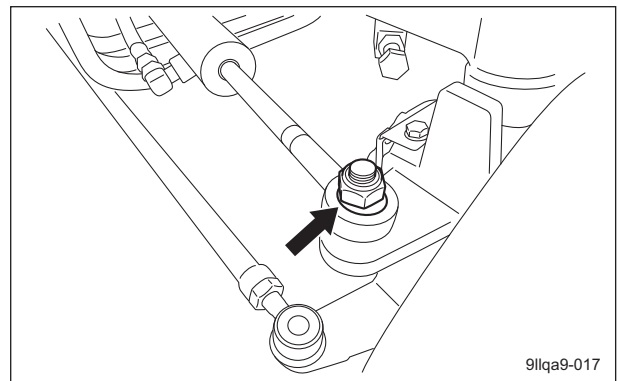

Lubricating Points\_002

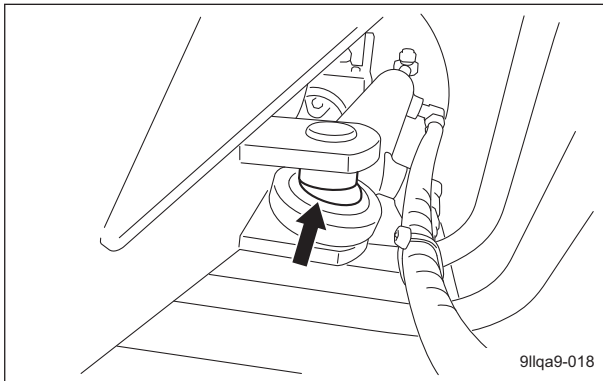

Lubricating Points\_003

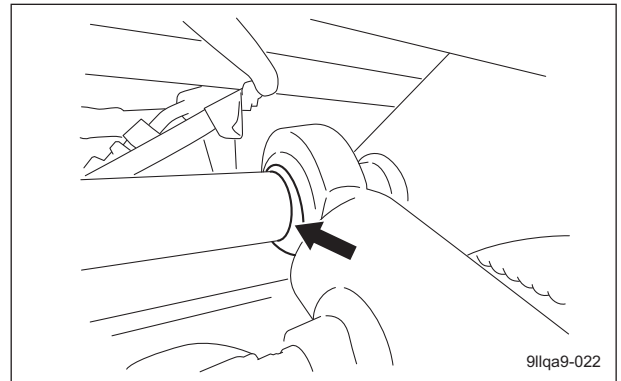

Lubricating Points\_007

2. Mower cylinder spherical bearing  
 There are two locations on each mower cylinder.

### Mower unit #1

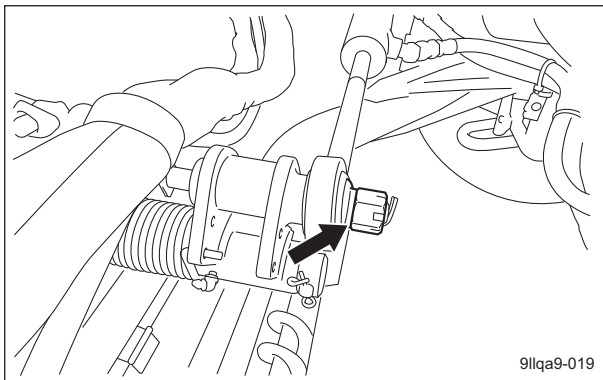

Lubricating Points\_004

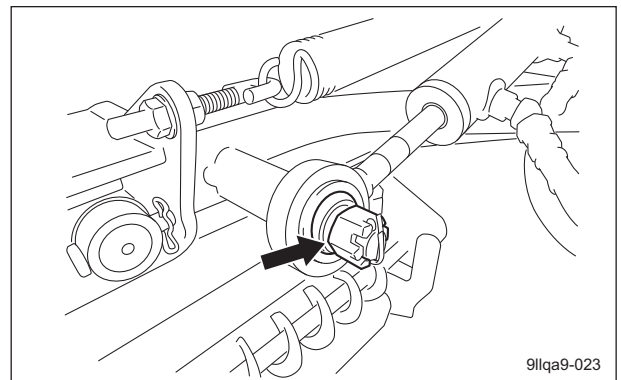

Lubricating Points\_008

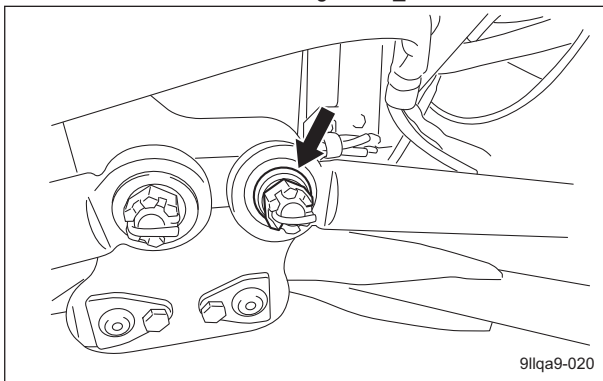

Lubricating Points\_005

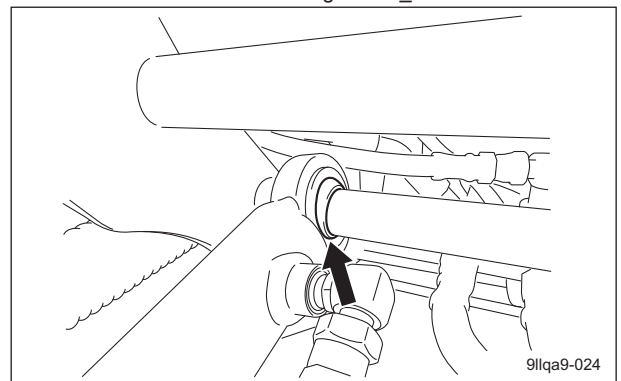

Lubricating Points\_009

### Mower unit #2

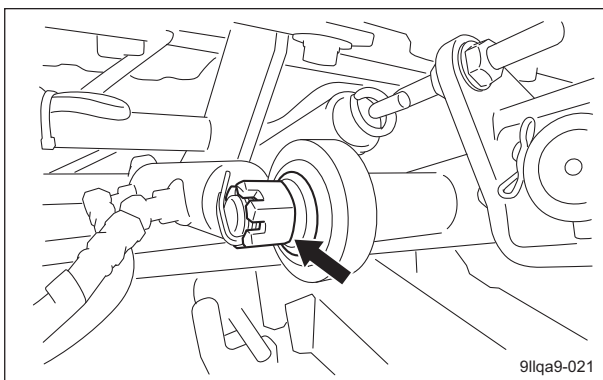

Lubricating Points\_006

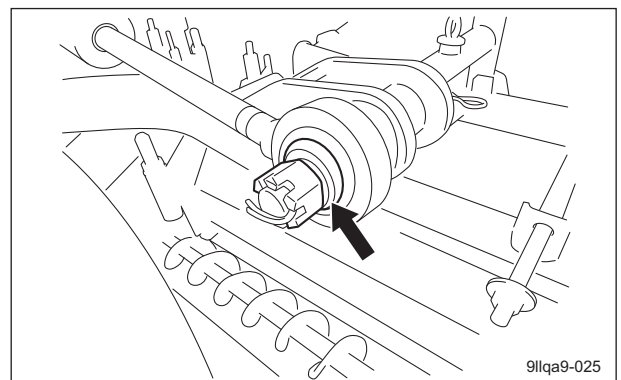

Lubricating Points\_010

# Maintenance

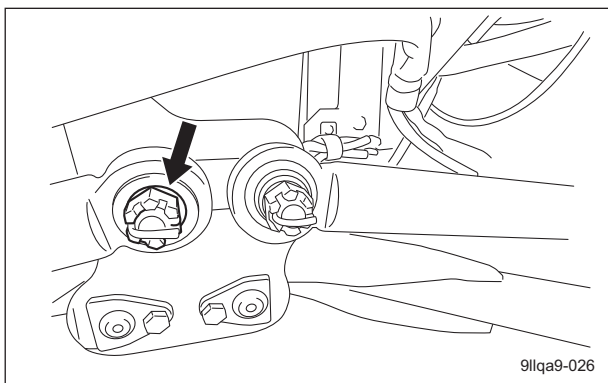

Lubricating Points\_011

## Mower unit #5

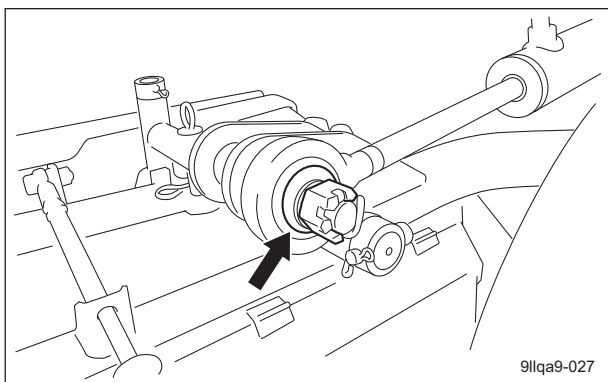

Lubricating Points\_012

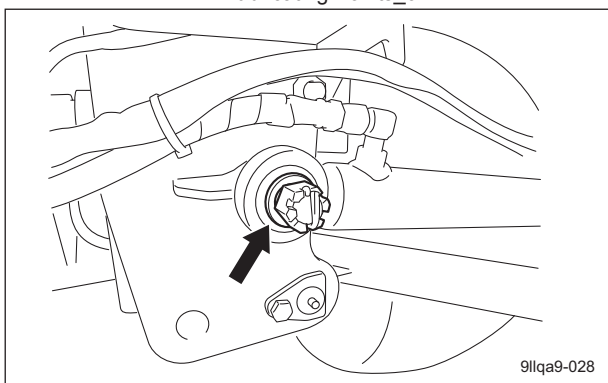

Lubricating Points\_013

## Maintenance Work

### Swiveling Mower Units #2 and #3

#### ⚠ Caution

Both the reel cutter (cutting cylinder) and the bed knife (bottom blade) are edged tools. Handle them carefully, since they could cut your hands or legs.

#### ⚠ Caution

Be careful not to inhale exhaust gas while swiveling the mower units.

#### Important

With the mower units LH66 installed, they can not swivel 90 degrees.

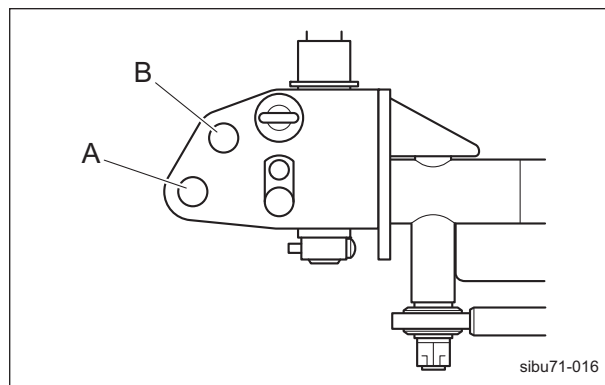

Swiveling Mower Units #2 and #3\_001

A	Mower unit swivel angle 90 °
B	Mower unit swivel angle 45 °

Maintenance can be performed more easily with mower units #2 and #3 swiveled.

1. Lower the mower units, and then stop the engine.



2. Remove the pipe pin, and then remove the grip pin.

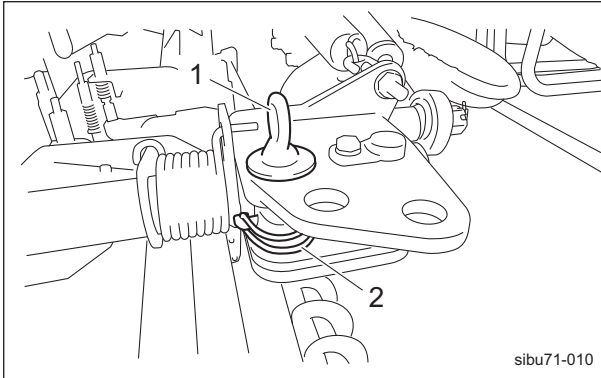

Swiveling Mower Units #2 and #3\_002

1	Grip pin
2	Pipe pin

3. Swivel the mower unit toward the outside of the main vehicle.

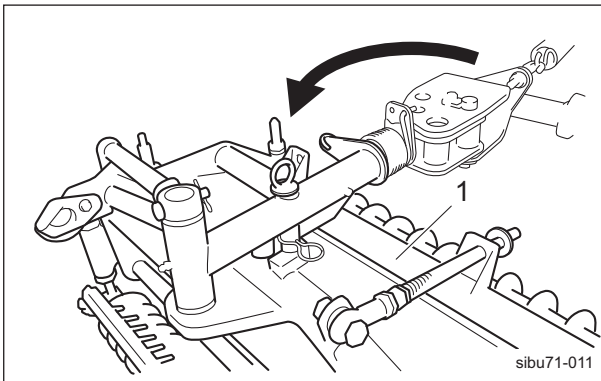

Swiveling Mower Units #2 and #3\_003

1	Mower unit
---	------------

4. Fully insert the grip pin into the locking hole for maintenance, and then install the pipe pin in the grip pin.

The installation location for the locking hole for maintenance differs depending on whether the mower unit is installed in the front or rear position.

Mower unit position: Front  
Use the rear locking hole (A) for maintenance.

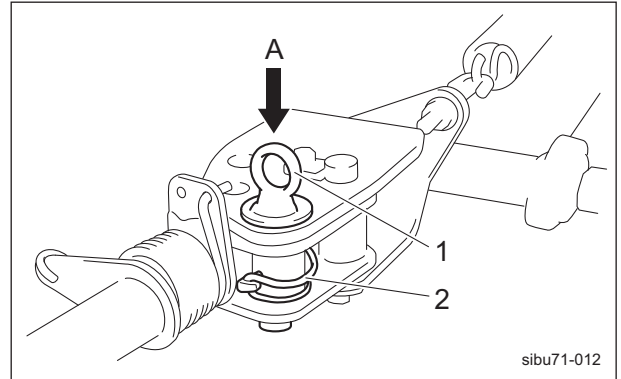

Swiveling Mower Units #2 and #3\_004

1	Grip pin
2	Pipe pin

Mower unit position: Rear  
Use the center locking hole (B) for maintenance.

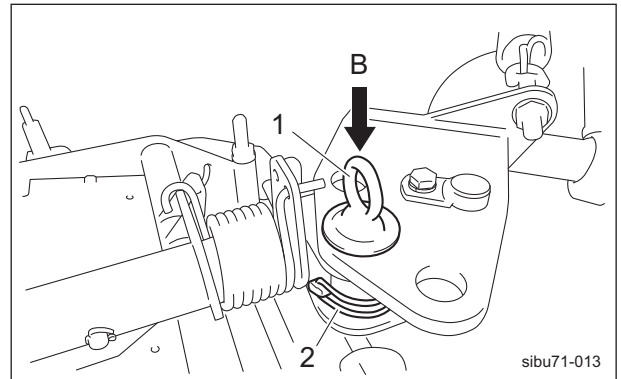

Swiveling Mower Units #2 and #3\_005

1	Grip pin
2	Pipe pin

# Maintenance

5. Start the engine, and then raise the mower units.

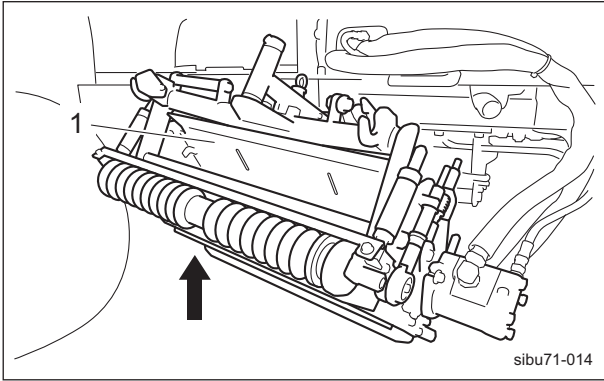

Swiveling Mower Units #2 and #3\_006

1	Mower unit
---	------------

6. After the maintenance is completed, reverse the procedure to return the machine to its original condition.

## Removing/Installing Tires

### Front Tires

Follow the steps below to remove the front tires:

1. Loosen the bolts.

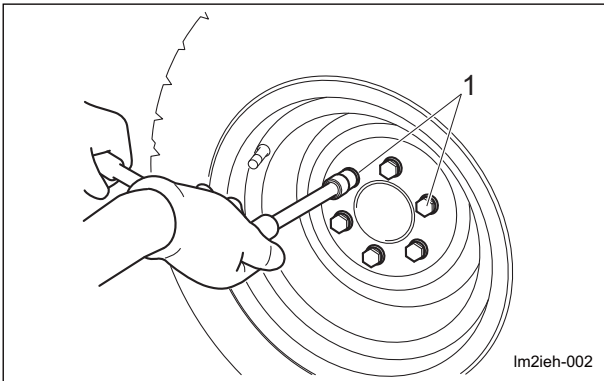

Front Tires\_001

1	Heat-treated bolt
---	-------------------

2. Securely place the jack beneath the jack-up point of the front left/right frame area, and then raise it until the tire lifts off the ground. "Jack-Up Points" (Page 5-22)
3. Remove the bolts.
4. Remove the tire from the wheel mounting seat.

**Important**

Tighten the bolts in the tightening order (diagonally).

For installing the front tires, reverse the removing procedure.

### Rear Tire

Follow the steps below to remove the rear tire.

1. Loosen the bolts.

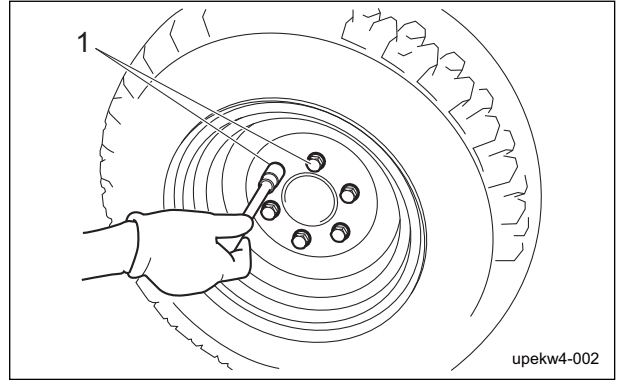

Rear Tire\_001

1	Bolt, heat-treated
---	--------------------

2. Securely place the jack beneath the jack-up point of the pivot, and then raise it until the tires lift off the ground. "Jack-Up Points" (Page 5-22)
3. Remove the bolts.
4. Remove the tire from the wheel mounting base.

**Important**

Tighten the bolts in the tightening order (diagonally).

For installing the rear tire, reverse the removing procedure.

## Adjustment of Belt Tension

**Warning**

Be sure to stop the engine before adjusting the belts.

**Important**

Before making sure of belt tension, rotate the belt several times.

If the belt becomes slack due to frequent use, it may jump or slip.

In addition, if it is overtightened, it may wear prematurely.

If necessary, adjust it, and always check the belt for appropriate tension.

### Fan Belt

1. Press the middle of the belt with your finger to check the belt tension.

The belt tension is appropriate when the belt slacks by approximately 10.0 mm (0.39 in) when you apply a force of 98 N (10 kgf) to the belt at the middle point between the pulleys.

2. If the belt tension is incorrect, loosen bolt A and bolt B (securing the alternator), and then move the alternator to adjust the tension.

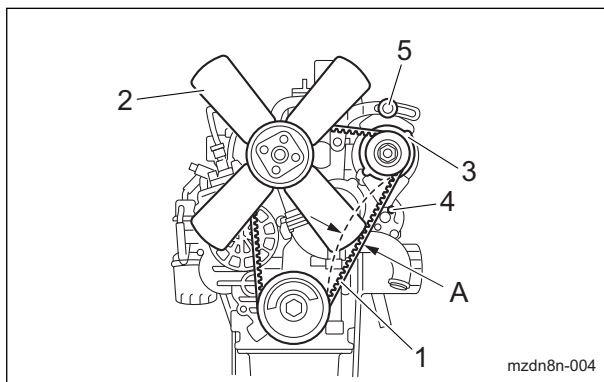

Fan Belt\_001

1	Fan Belt
2	Blade
3	Alternator
4	Bolt A
5	Bolt B
A	10 mm (0.39 in)

## Adjustment of Parking Brake

**Caution**

Make sure that the brake wire is not cracked or damaged.

**Important**

Make sure that the brake is effective on slopes and that it is not applied any longer when you release it.

Adjust the parking brake whenever there is any abnormality.

1. Stop the engine.
2. Remove the step cover.
3. Follow the steps below to adjust the parking brake.

- [1] Depress the locking pedal while firmly depressing the brake pedal to lock it and engage the latch in a notch.

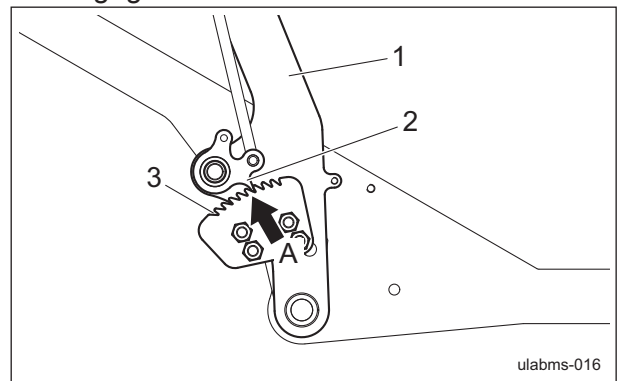

Adjustment of Parking Brake\_001

1	Brake pedal
2	Latch
3	Notch
A	Fourth or fifth notch

# Maintenance

[2] Adjust the adjustment bolt so that the latch is positioned in the fourth or fifth notch from the top.

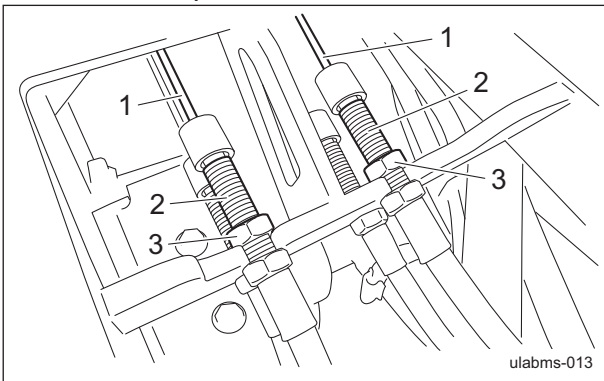

Adjustment of Parking Brake\_002

1	Brake wire
2	Adjustment bolt
3	Lock nut

3. Follow the steps below to adjust the brake. Adjust it so that the play of brake wire will be as small as possible with the latch positioned at the first notch from the top.

[1] Push the locking pedal while applying mild pressure to the brake pedal with a hand so that the brake pedal will be locked with the latch positioned at the first notch.

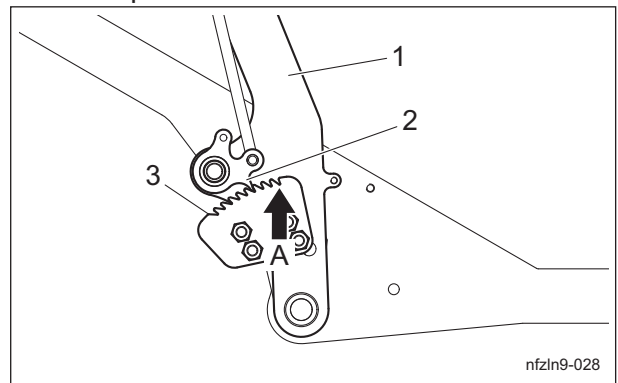

Adjustment of Brake\_002

1	Brake pedal
2	Latch
3	Notch
A	First notch

## Adjustment of Brake

### Caution

If the brake wire is cut, the machine will be unable to stop.  
If the brake wire is cracked or damaged, immediately replace it with a new one.  
If the brake is not sufficiently effective, adjust the brake wire.

### Important

Make sure that the brake is effective on slopes and that it is not applied any longer when you release it.  
Adjust the parking brake system whenever there is any abnormality.

1. Stop the engine.
2. Remove the step cover.

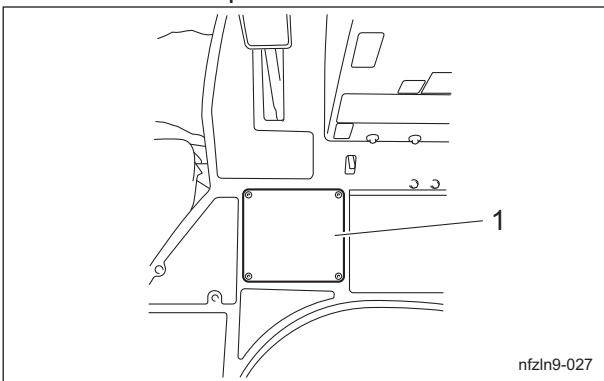

Adjustment of Brake\_001

1	Step cover
---	------------

[2] Adjust the travel of the brake pedal by tightening the brake wire adjustment bolt.

- If the brake pedal play is too large, the braking power will be decreased and the pedaling will be light.
- If the brake pedal play is too small, the braking power will be increased and the pedaling will be heavy.

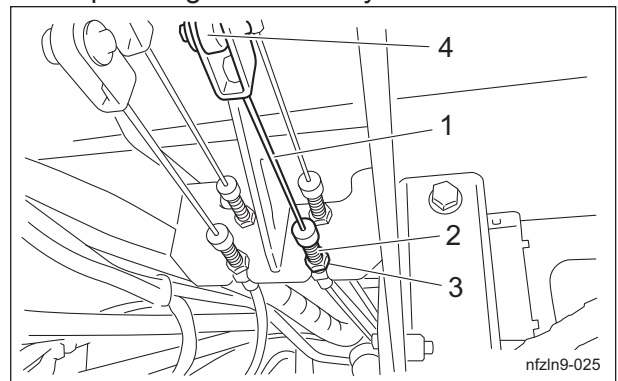

Adjustment of Brake\_003

1	Brake wire
2	Adjustment bolt
3	Lock nut
4	Brake pedal

4. Install the step cover.
5. Start the engine.

6. Drive the machine to check the following.
- Make sure that the brake is effective when depressing the brake pedal all the way firmly.
  - Make sure that heat is not generated in the brake area.
  - Make sure that the left and right brakes are equally effective.

 **Caution**

It would be extremely dangerous and may result in an unexpected accident if the left and right brakes are not equally effective.

7. If the left and right brakes are not equally effective, make fine adjustments with the adjustment bolt on the brake wire.

#### Break-In of Brakes

If the brake shoes or brake pads are worn, replace them with new ones. Immediately after replacement, drive to break in the brakes if the effectiveness of the brakes is low. While driving, lightly operate the brakes to break in the contact areas.

### Adjusting The Neutral Position of The Piston Pump

 **Caution**

Make sure not to touch rotating tires.

 **Caution**

While adjusting the neutral position, the machine may start to move. Securely place jacks beneath the jack-up points, and then raise the machine until all tires lift off the ground.

If the machine moves forward or backward while the traveling pedals are released, they are not set to the neutral position. Follow the steps below to make adjustments.

1. Stop the engine.
2. Securely place jacks beneath the jack-up points, and then lift the machine off the ground.  
"Jack-Up Points" (Page 5-22)
3. Make sure that no tires get contact with the jack stand.
4. Open the underseat cover.
5. Start the engine, and rev it up to the maximum rpm.
6. Adjust the neutral position.

**Note:**

The lock nut uses a 1/2 inch wrench, and the traction adjusting cam uses a 1/4 inch wrench.

Follow the steps below to adjust the neutral position.

[1] Loosen the lock nuts.

[2] Slowly rotate the traction adjusting cam until all tires stop.

- If the tires move in the direction of forward travel, rotate the traction adjusting cam clockwise.
- If the tires move in the direction of backward travel, rotate the traction adjusting cam counterclockwise.

Find the position where all tires stop, and then, while holding the traction adjusting cam in place, secure it with the lock nut.

# Maintenance

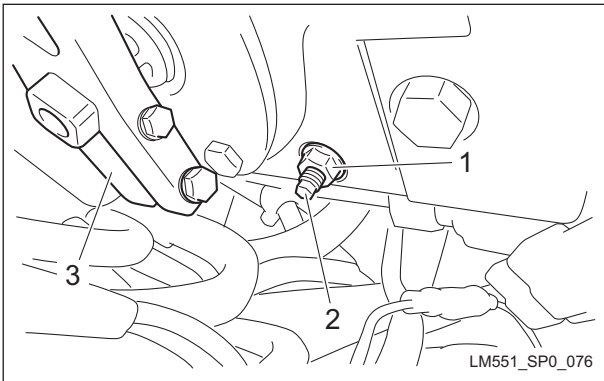

Adjusting The Neutral Position of The Piston Pump\_001

1	Lock nut
2	Traction adjusting cam
3	Cam lever

7. Check that the tires do not move.

## Adjustment of Control Arm

The control arm can be adjusted up or down and forward or backward. Adjust the position to fit the operator.

1. Loosen the nut.
2. Slide the control arm up or down and forward or backward to the appropriate position.
3. Tighten the nut.

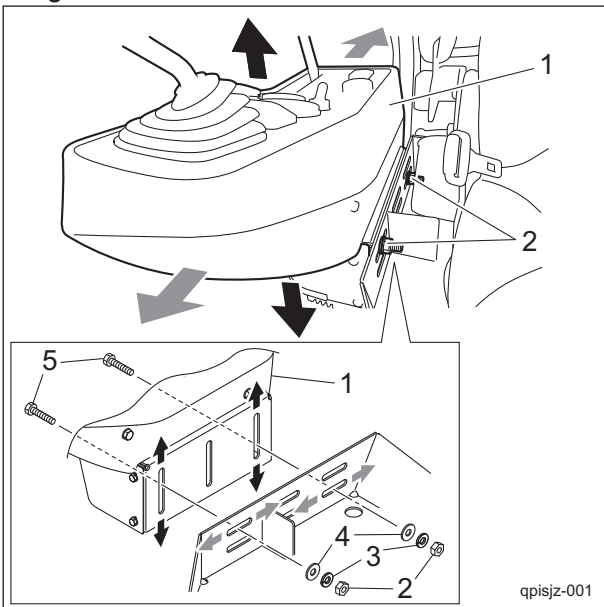

Adjustment of Control Arm\_001

1	Control arm
2	Nut
3	Spring washer
4	Washer
5	Bolt

## Adjustment of Stoppers

### Important

The installation method and installation position of the stoppers differ depending on the mower unit model.

The stopper is installed to prevent the mower arm from interfering with the frame when swiveling the mower units #2 and #3. Install in the appropriate position.

### Note:

The stopper is not used when the mower units LS66 installed.

The stopper installation position for each mower unit model is described below.

A: Installed at the lower position

- LS62
- LH52

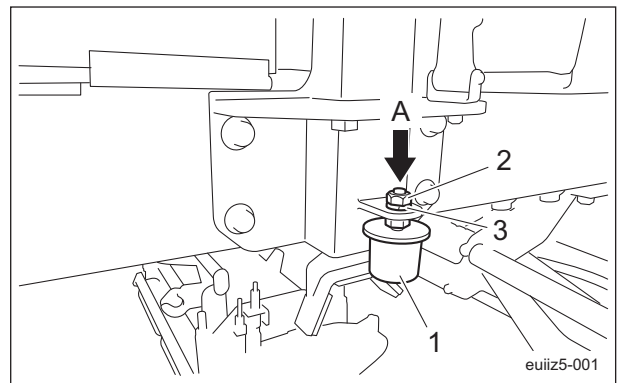

Adjustment of Stoppers\_001

1	Stopper
2	Nut
3	Spring washer

B: Installed at the upper position

- LH62

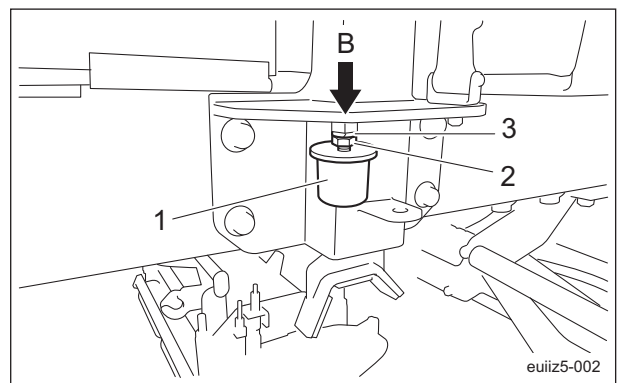

Adjustment of Stoppers\_002

1	Stopper
2	Nut
3	Spring washer

## Adjustment of Mower Locking Pin

The mower locking pin can prevent or allow tilting of the mower units.

Adjust according to the operating conditions.

Fixed:

- The mowing line while traveling straight ahead is a straight line. (The mowing line is easy to see.)
- The mower units do not tilt while operating on slopes, and incomplete mowing can be reduced.

Released:

- It is appropriate when turning while mowing or it is easy to follow undulations.

1. On a level surface, lower all mower units.
2. Apply the parking brake, and then stop the engine.
3. Adjust the position of the mower locking pin, and then insert the cotter pin.

To fix:

Insert the cotter pin into the upper hole in the mower locking pin.

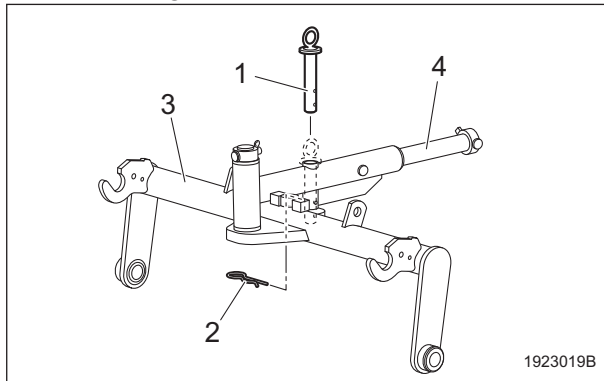

Adjustment of Mower Locking Pin\_001

1	Mower locking pin
2	Cotter pin
3	Mower arm
4	Mower coupling

To release:

Insert the cotter pin into the lower hole in the mower locking pin.

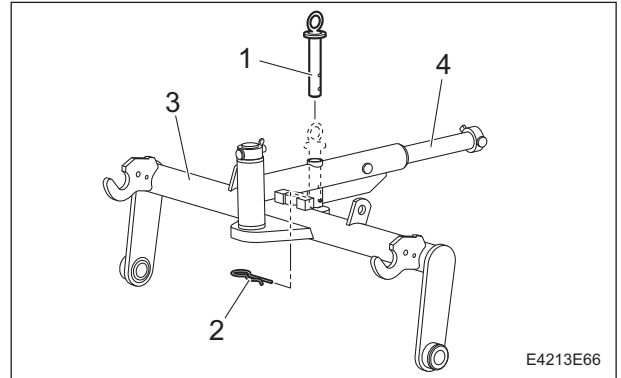

Adjustment of Mower Locking Pin\_002

1	Mower locking pin
2	Cotter pin
3	Mower arm
4	Mower coupling

## Adjustment of Mower Stabilizer

Note:

Depending on the specifications, this function may not be available.

### Important

After adjusting the cutting height, adjust the mower stabilizer.

The mower stabilizer stabilizes the mower units and prevents an undulating finish (a phenomenon called Marcelling).

1. On a level surface, lower all mower units.
2. Apply the parking brake, and then stop the engine.
3. Loosen the lock nut.
4. Tighten the nut to adjust the length of the spring (compression).
  - Mower #1 to #5: 140.0 mm (5.51 in)
5. Tighten the lock nut.

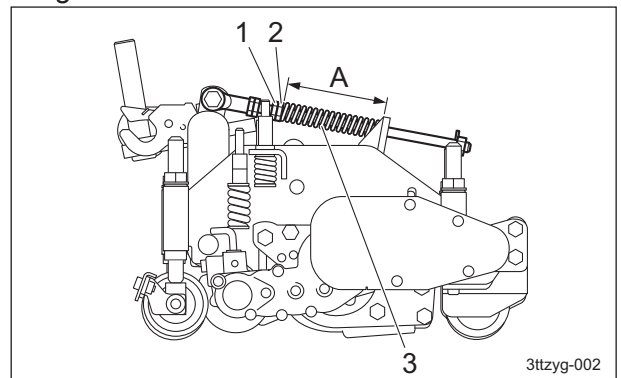

Adjustment of Mower Stabilizer\_001

# Maintenance

1	Lock nut
2	Nut
3	Spring
A	140.0 mm (5.51 in)

## Adjustment of Stopper Nuts

**Note:**

Depending on the specifications, this function may not be available.

The stopper nut adjusts the movement range of the mower unit.

1. Apply the parking brake, and then stop the engine.

**Important**

When a grass catcher is installed on LH52 (5-inch mower unit), a large movement range of the mower will cause the grass catcher to come into contact with the front roller when the mower unit is raised.

Exercise care in the position of the stopper nut.

2. Turn the nut to adjust the length of A.

- Mower #1, #4 and #5: 15.0 mm (0.59 in)
- Mower #2 and #3: 40.0 mm (1.57 in)

When a grass catcher is installed on LH52 (5-inch mower unit):

- Mower #1, #4 and #5: 30.0 mm (1.18 in)
- Mower #2 and #3: 40.0 mm (1.57 in)

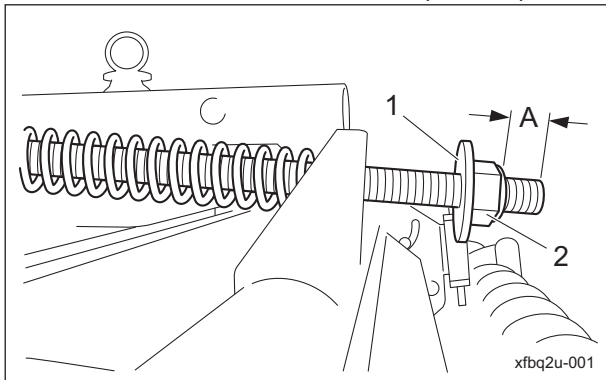

Adjustment of Stopper Nuts\_001

1	Washer
2	Nut
A	Length

## Adjustment of Mower Unit Leveling Spring

A coil spring is installed on the mower unit coupling.

This keeps the mower unit level.

Adjust the coil spring with the holes in the lift arm.

### Mower unit #1

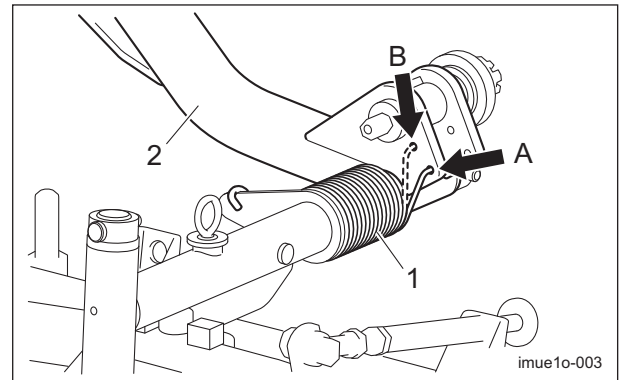

Adjustment of Mower Unit Leveling Spring\_001

1	Coil spring
2	Lift arm
A	22 in mower unit
B	26 in mower unit

### Mower unit #2

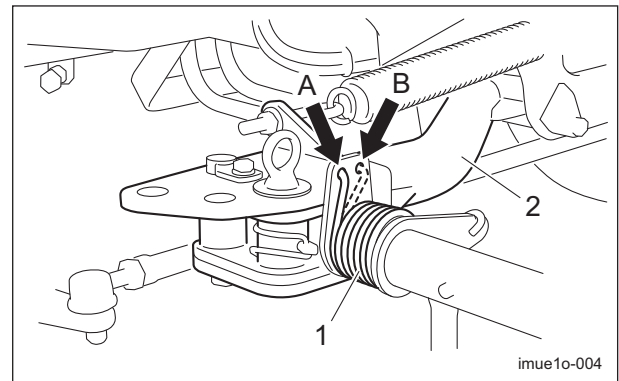

Adjustment of Mower Unit Leveling Spring\_002

1	Coil spring
2	Lift arm
A	22 in mower unit
B	26 in mower unit



### Mower unit #3

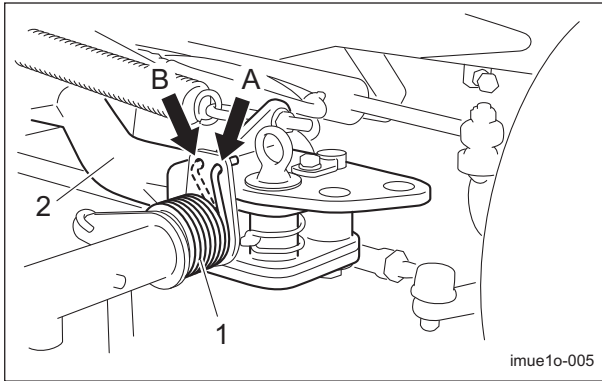

Adjustment of Mower Unit Leveling Spring\_003

1	Coil spring
2	Lift arm
A	22 in mower unit
B	26 in mower unit

1	Coil spring
2	Lift arm
A	Light spring load (standard position)
B	Heavy spring load

### Mower unit #5 22 in mower unit

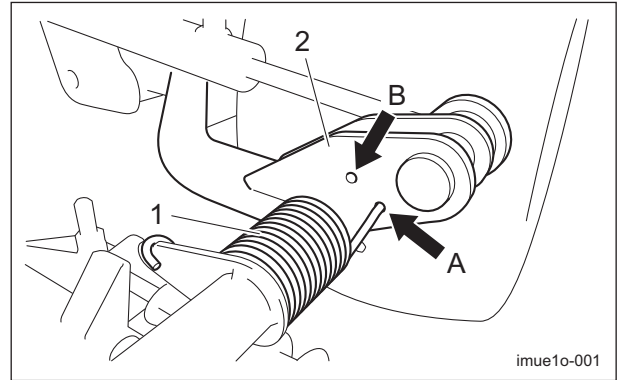

Adjustment of Mower Unit Leveling Spring\_006

1	Coil spring
2	Lift arm
A	Light spring load (standard position)
B	Heavy spring load

### Mower unit #4 22 in mower unit

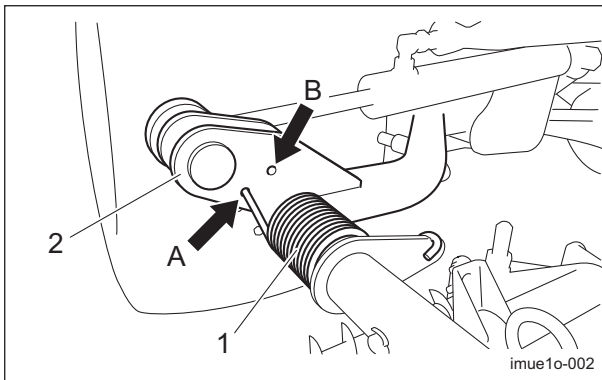

Adjustment of Mower Unit Leveling Spring\_004

1	Coil spring
2	Lift arm
A	Light spring load (standard position)
B	Heavy spring load

### 26 in mower unit

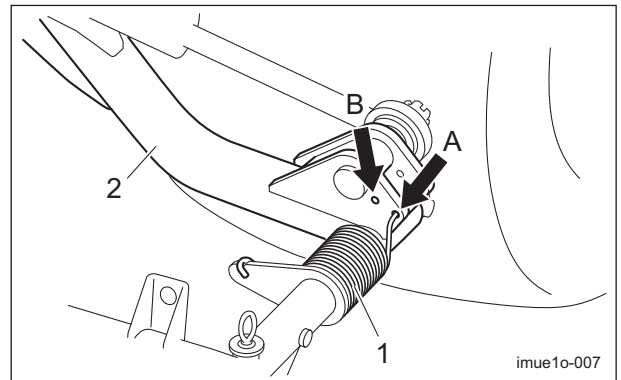

Adjustment of Mower Unit Leveling Spring\_007

1	Coil spring
2	Lift arm
A	Light spring load (standard position)
B	Heavy spring load

### 26 in mower unit

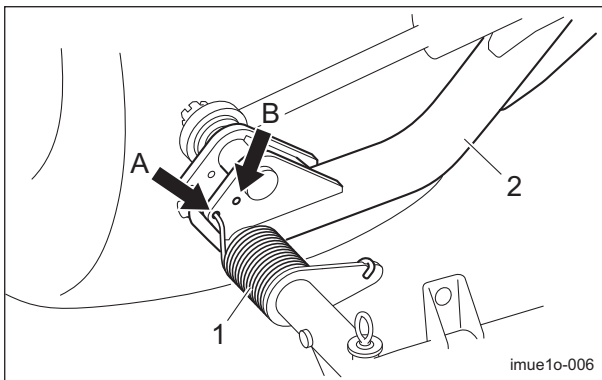

Adjustment of Mower Unit Leveling Spring\_005

Maintenance

# Maintenance

## Adjustment of Positions of Mower Units #2 and #3

**Important**

When the grass catcher is installed, move the mower units to the rear position.

Mower units #2 and #3 can be slid to the front position or rear position. The slide distance is 200 mm (7.87 in).

1. On a level surface, lower all mower units.
2. Move the mower unit up/down lever to the neutral position.
3. Depress the locking pedal while firmly depressing the brake pedal to lock it.
4. Stop the engine.
5. Remove the clamps from the mower unit up/down cylinder hoses.

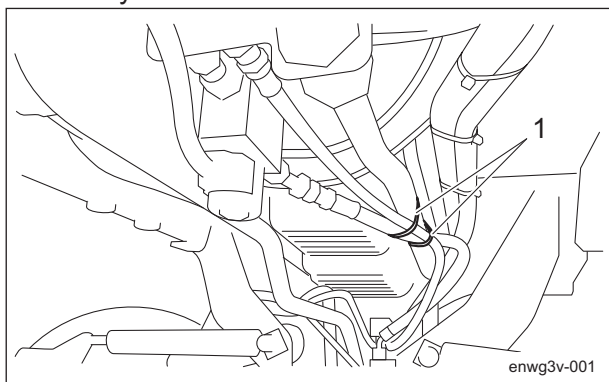

Adjustment of Positions of Mower Units #2 and #3\_001

1	Clamp
---	-------

**Important**

Since mower units #2 and #3 are connected, slide them at the same time.

6. Follow the steps below to slide the mower units.

· When moving to the front position:

- [1] Loosen bolt A of mower unit #3.
- [2] Remove bolts B of mower unit #3.

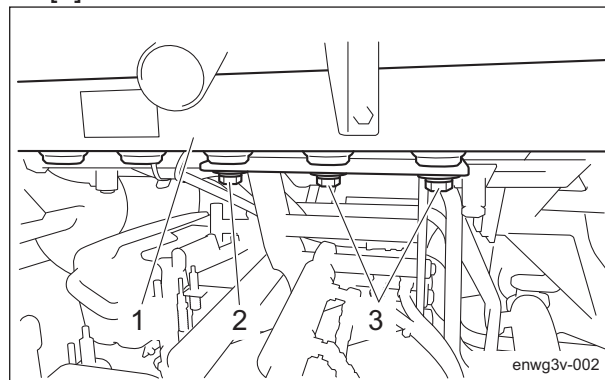

Adjustment of Positions of Mower Units #2 and #3\_002

1	Frame
2	Bolt A
3	Bolt B

[3] In the same way, loosen bolt A and remove bolts B of mower unit #2.

[4] Slide mower units #2 and #3 from the rear position to the front position.

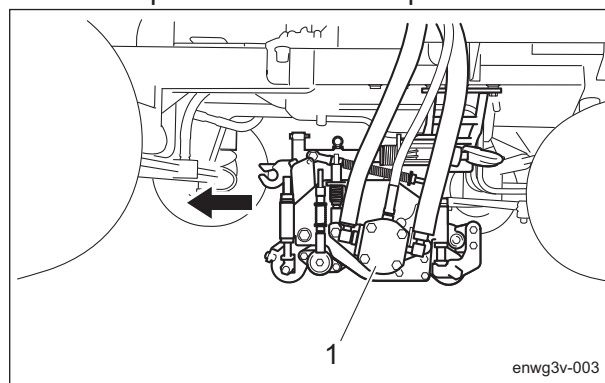

Adjustment of Positions of Mower Units #2 and #3\_003

1	Mower unit
---	------------

[5] Install bolts B of mower unit #3.

[6] In the same way, install bolts B of mower unit #2.

[7] Tighten bolt A and bolts B on both sides.

- When moving to the rear position:
- [1] Loosen bolt A of mower unit #3.
- [2] Remove bolts B of mower unit #3.

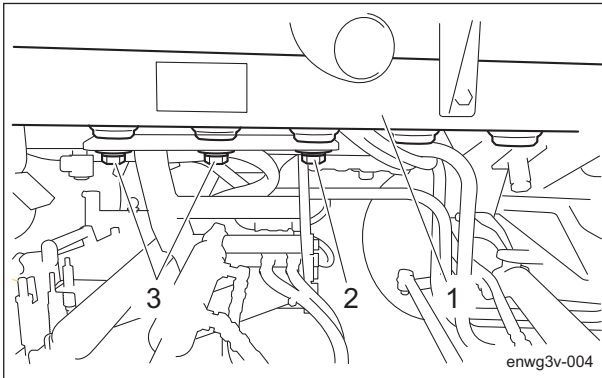

Adjustment of Positions of Mower Units #2 and #3\_004

1	Frame
2	Bolt A
3	Bolt B

- [3] In the same way, loosen bolt A and remove bolts B of mower unit #2.
- [4] Slide mower units #2 and #3 from the front position to the rear position.

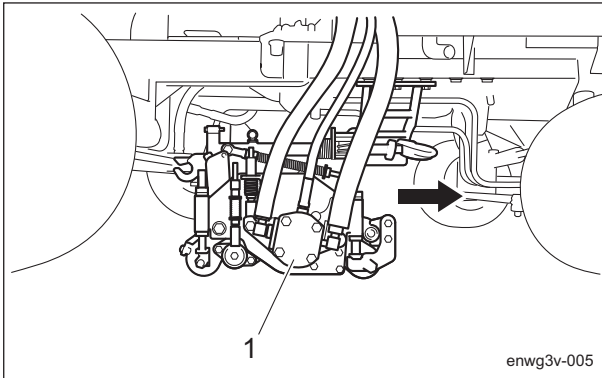

Adjustment of Positions of Mower Units #2 and #3\_005

1	Mower unit
---	------------

- [5] Install bolts B of mower unit #3.
- [6] In the same way, install bolts B of mower unit #2.
- [7] Tighten bolt A and bolts B on both sides.
- 7. Adjust the mower stoppers of mower units #2 and #3.
- "Adjustment of Mower Stoppers for Mower Unit #2 and #3" (Page 5-42)
- 8. Re-secure the mower unit up/down cylinder hoses with clamps.

## Adjustment of Mower Stopper

### Adjustment of Mower Stoppers for Mower Unit #1

The mower stopper is installed to prevent the mower unit from interfering with the frame. The attaching direction of the mower stopper for mower unit #1 differs according to the type of mower unit.

Install in the appropriate direction.

1. Loosen the nuts of the right and left mower stoppers.
2. Place the right and left mower stoppers to the highest position and attach them temporarily.
3. On a level surface, raise all mower units.
4. Depress the locking pedal while firmly depressing the brake pedal to lock it.
5. Stop the engine.
6. Tighten the nuts of the right and left mower stoppers in a position where the mower unit is leveled and the mower arm contacts the center of the mower stopper.

### LH62

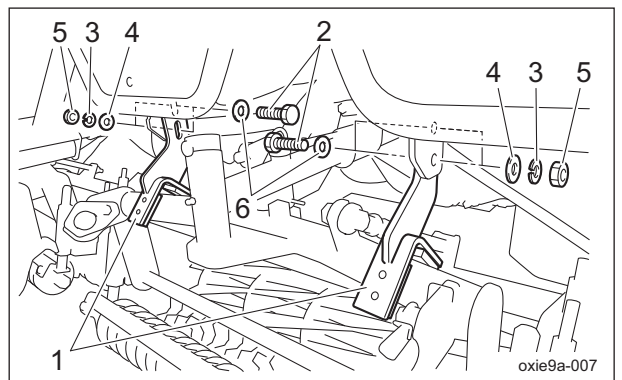

Adjustment of Mower Stoppers for Mower Unit #1\_001

1	Mower stopper
2	Bolt
3	Spring washer
4	Washer
5	Nut
6	Washer

# Maintenance

LH66 · LH52 · LS62 · LS66

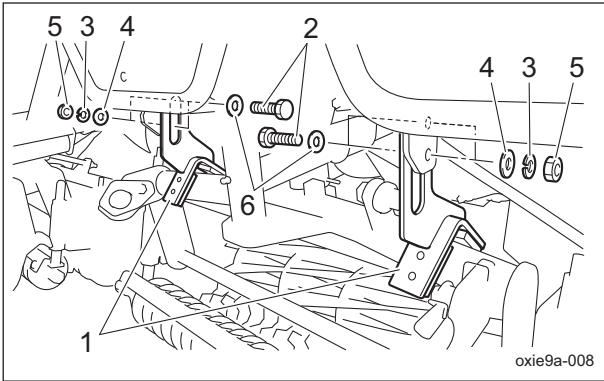

Adjustment of Mower Stoppers for Mower Unit #1\_002

1	Mower stopper
2	Bolt
3	Spring washer
4	Washer
5	Nut
6	Washer

## Adjustment of Mower Stoppers for Mower Unit #2 and #3

The mower stopper is installed to prevent the mower unit from interfering with the frame. The type and attaching direction of the mower stopper for mower unit #2 and #3 differ according to the type of mower unit. And adjust the attaching position of the mower stopper for mower unit #2 and #3 according to the attaching position (front or rear) of the mower unit. Install in the appropriate direction.

1. On a level surface, lower all mower units.
2. Depress the locking pedal while firmly depressing the brake pedal to lock it.
3. Stop the engine.
4. Open the hood.
5. Open the underseat cover.

## 6. Remove the nuts of the mower stopper.

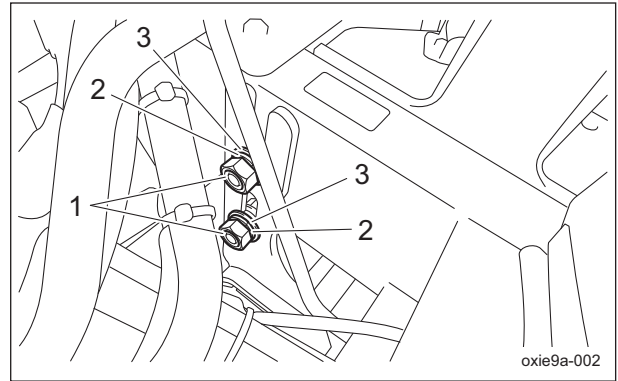

Adjustment of Mower Stoppers for Mower Unit #2 and #3\_001

1	Nut
2	Spring washer
3	Washer

## 7. Adjust the mower stopper position.

- To set the mower unit in the front position, attach the mower stopper in the "front position".
- To set the mower unit in the rear position, attach the mower stopper in the "rear position".

### Mower unit #2

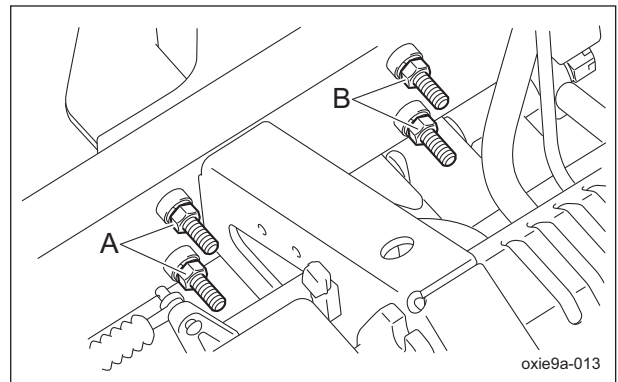

Adjustment of Mower Stoppers for Mower Unit #2 and #3\_002

A	Mower stopper front position
B	Mower stopper rear position

Mower unit #3

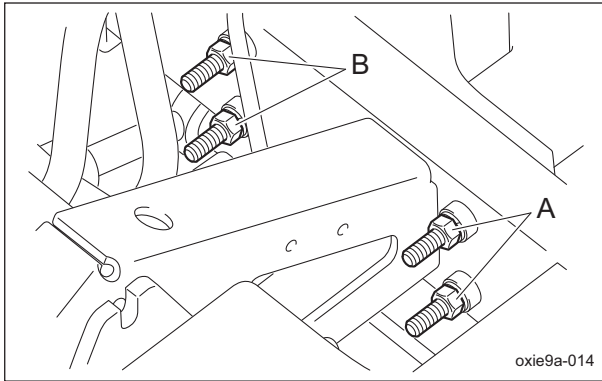

Adjustment of Mower Stoppers for Mower Unit #2 and #3\_003

A	Mower stopper front position
B	Mower stopper rear position

8. Attach the mower stoppers temporarily.
9. Start the engine.
10. Raise all mower units.
11. Tighten the mower stopper nuts previously attached in a position where the mower unit is leveled and the mower stopper contacts the mower arm.

Note:

The relationship between the mower unit type and the mower stopper is as follows.

LH62

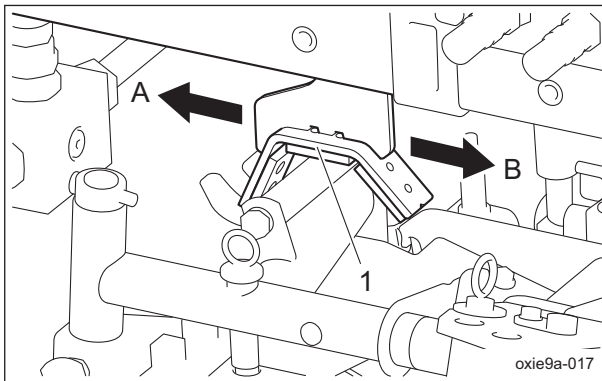

Adjustment of Mower Stoppers for Mower Unit #2 and #3\_004

1	Mower stopper
A	Front
B	Rear

LH66

Mower unit #2

After installing the mower stoppers, press the stopper auxiliary fitting COMP firmly against the bottom side of the frame and secure it with the bolts.

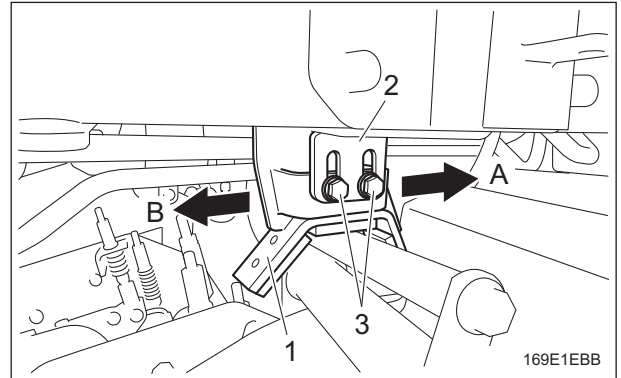

Adjustment of Mower Stoppers for Mower Unit #2 and #3\_005

1	Mower stopper
2	Stopper auxiliary fitting COMP
3	Bolt
A	Front
B	Rear

LH66

Mower unit #3

After installing the mower stoppers, press the stopper auxiliary fitting COMP firmly against the bottom side of the frame and secure it with the bolts.

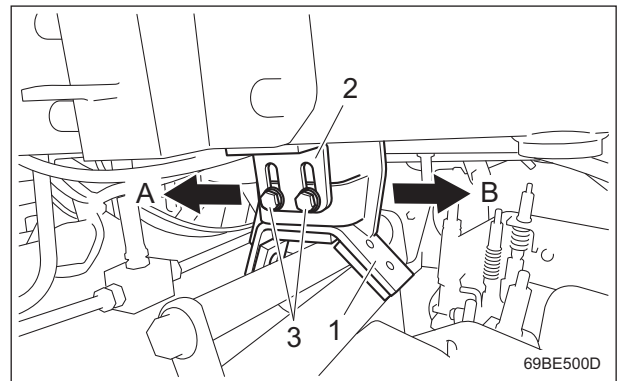

Adjustment of Mower Stoppers for Mower Unit #2 and #3\_006

1	Mower stopper
2	Stopper auxiliary fitting COMP
3	Bolt
A	Front
B	Rear

Maintenance

# Maintenance

## LH52 · LS62

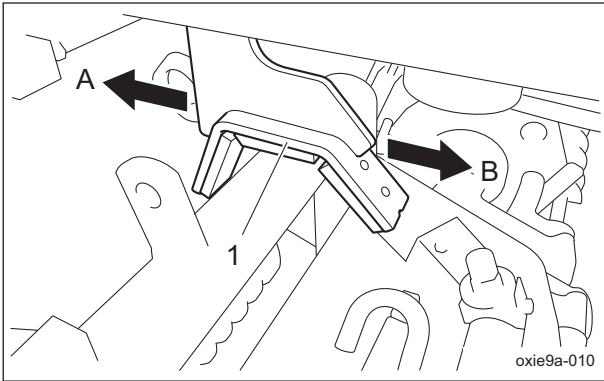

Adjustment of Mower Stoppers for Mower Unit #2 and #3\_007

1	Mower stopper
A	Front
B	Rear

## LS66

### Mower unit #2

After installing the mower stoppers, press the stopper auxiliary fitting COMP firmly against the bottom side of the frame and secure it with the bolts.

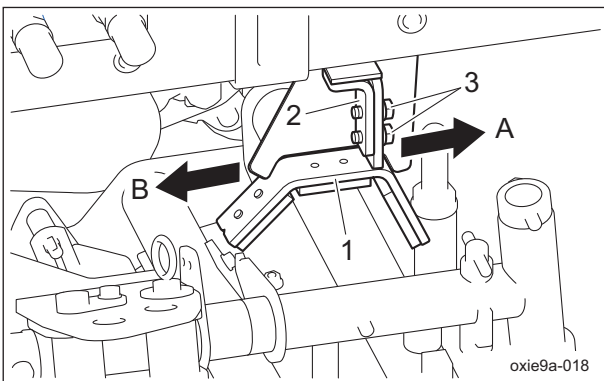

Adjustment of Mower Stoppers for Mower Unit #2 and #3\_008

1	Mower stopper
2	Stopper auxiliary fitting COMP
3	Bolt
A	Front
B	Rear

## LS66

### Mower unit #3

After installing the mower stoppers, press the stopper auxiliary fitting COMP firmly against the bottom side of the frame and secure it with the bolts.

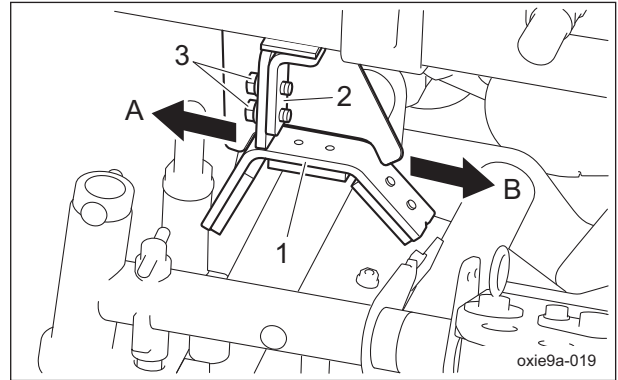

Adjustment of Mower Stoppers for Mower Unit #2 and #3\_009

1	Mower stopper
2	Stopper auxiliary fitting COMP
3	Bolt
A	Front
B	Rear

## Adjustment of Mower Stoppers for Mower Unit #4 and #5

The mower stopper is installed to prevent the mower unit from interfering with the frame.

The attaching position of the mower stopper for mower unit #4 and #5 differs according to the type of mower unit.

Install in the appropriate direction.

The relationship between the mower unit type and the mower stopper attaching position.

## LH62

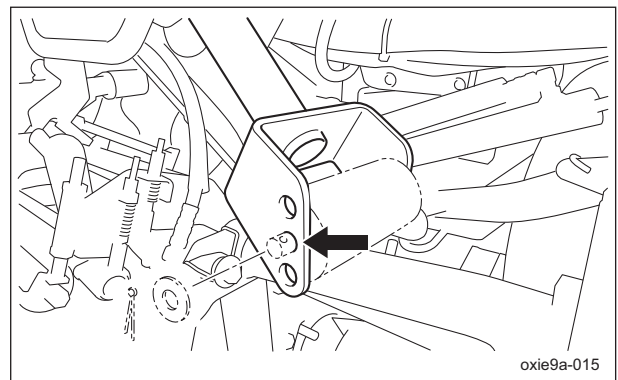

Adjustment of Mower Stoppers for Mower Unit #4 and #5\_001

## LH52 • LS62

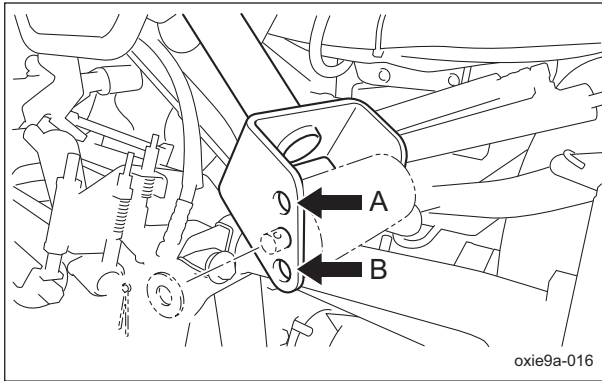

Adjustment of Mower Stoppers for Mower Unit #4 and #5\_002

A	LS62
B	LH52

1. On a level surface, lower all mower units.
2. Depress the locking pedal while firmly depressing the brake pedal to lock it.
3. Stop the engine.
4. Follow the steps below to adjust the mower stopper position.

[1] Remove the cotter pin and washer.

[2] Install the roller shaft and rubber roller in the specified position.

[3] Attach the cotter pin and washer.

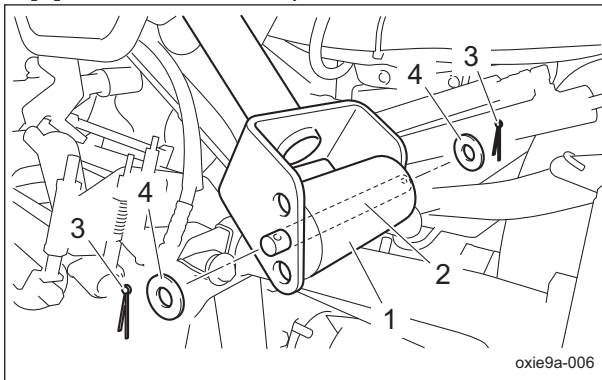

Adjustment of Mower Stoppers for Mower Unit #4 and #5\_003

1	Rubber roller
2	Roller shaft
3	Cotter pin
4	Washer

## LH66 • LS66

For the mower unit LH66 • LS66, the adjustment is not required.

## Change of Coolant

### ⚠ Caution

Do not touch the radiator or coolant during engine operation or immediately after the engine has been turned off. Otherwise, you may get burned.

### ⚠ Caution

Change coolant after the engine has well cooled down.

### ⚠ Caution

The radiator cap is pressurized. If you remove the radiator cap while the engine is overheated, hot steam will burst out, possibly resulting in burns. Make sure that the water temperature and pressure are reduced, and then grab the cap with a thick cloth and gradually open the cap.

### Important

When changing the coolant, be sure to drain it into a container and discard it in accordance with local laws and regulations.

### Important

When changing the coolant, be sure to mix clean water and antifreeze (long-life coolant), and then pour it into the radiator and reserve tank.

### Important

Tightly close the radiator cap. If the cap is loose or incorrectly installed, the engine will be overheated due to water leakage, resulting in engine damage.

When mixing antifreeze and clean water, refer to "Relationship between concentration of long-life coolant (LLC) and freezing temperature" below for the mixing ratio.

# Maintenance

Relationship between concentration of long-life coolant (LLC) and freezing temperature

Freezing temperature	LLC concentration (volume %)
Down to -10 °C (14 °F)	20 %
Down to -15 °C (5 °F)	30 %
Down to -20 °C (-4 °F)	35 %
Down to -25 °C (-13 °F)	40 %

1. Stop the engine, and then allow the radiator to cool.
2. Open the hood.
3. Follow the steps below to drain the coolant.

[1] Position a container to drain the coolant into.

[2] Remove the drain plug from the radiator.

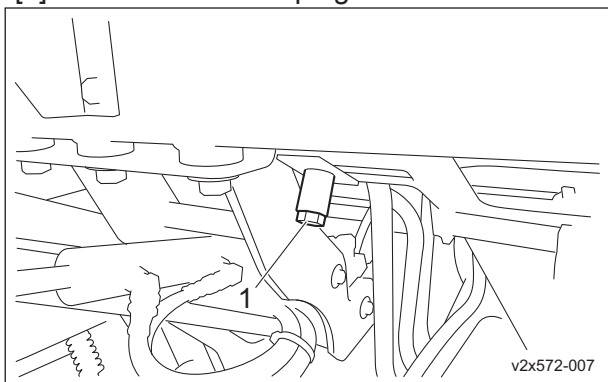

Change of Coolant\_001

1	Radiator drain plug
---	---------------------

[3] Remove the radiator cap.

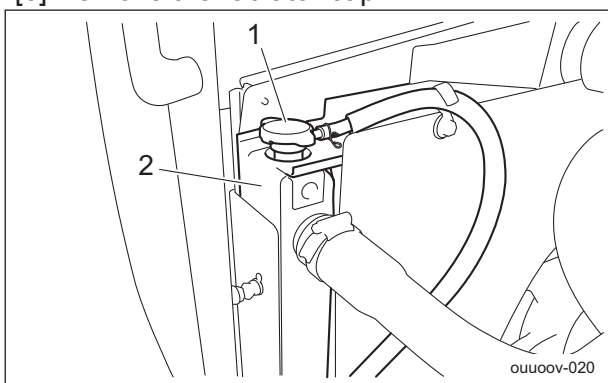

Change of Coolant\_002

1	Radiator cap
2	Radiator

[4] Remove the reserve tank.

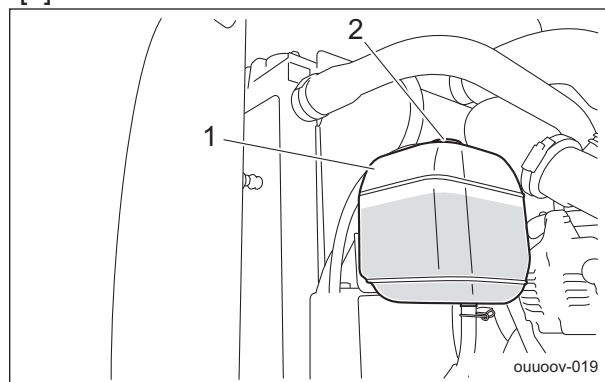

Change of Coolant\_003

1	Reserve tank
2	Reserve tank cap

[5] Open the reserve tank cap, and then drain the coolant.

4. Install the reserve tank.
5. Clean the radiator with clean water to remove any debris or rust.
6. Drain all water from the radiator.
7. Follow the steps below to fill with coolant. The coolant quantity, including the reserve tank, is 12.0 dm<sup>3</sup> (12.0 L).
- [1] Install the drain plug.
- [2] Supply clean water and antifreeze into the radiator up to the radiator cap opening.
- [3] Close the radiator cap.
- [4] Supply clean water and antifreeze into the reserve tank up to the "FULL" mark.
- [5] Close the reserve tank cap.
8. Start the engine, and then idle for several minutes to bleed air from the system.
9. Stop the engine, and then allow the radiator to cool.
10. Check if the coolant level in the reserve tank is between "FULL" and "LOW", and then supply coolant if necessary.
11. Close the hood.



## Change of Hydraulic Oil

**⚠ Caution**

Be careful with hot oil, which could cause burns if it contacts your skin.

**Important**

When you change the hydraulic oil, be sure to drain it into a container and discard it in accordance with local laws and regulations.

**Important**

If the hydraulic oil emulsifies or if it becomes even slightly less transparent, change the oil immediately.

**Important**

Use Shell Tellus S2M46 (or equivalent) as hydraulic oil. In case of an equivalent, consult Characteristics of Hydraulic Oil and use hydraulic oil whose characteristics are superior to those of the specific hydraulic oil. Especially regarding kinematic viscosity and viscosity index, use of hydraulic oil whose figures are less than those of the specified hydraulic oil will cause a malfunction in the hydraulic circuit.

**Note:**

**Characteristics of Hydraulic Oil**

Specified Hydraulic Oil		Shell Tellus S2M46
ISO Viscosity Grade		ISO VG46
Density	15 °C (59 °F)	0.873 g/cm <sup>3</sup> (0.0315 lb/in <sup>3</sup> )
API Gravity		30.6
Flash Point (Open Cup)		230 °C (446 °F)
Pour Point		-30 °C (-22 °F)
Kinematic	40 °C (104 °F)	46 mm <sup>2</sup> /s (46 cSt)
Viscosity	100 °C (212 °F)	7 mm <sup>2</sup> /s (7 cSt)
Viscosity Index		109

- Follow the steps below to remove the old oil.
  - Start and run the engine to warm up the oil.
  - On a level surface, lower the mower units, and then stop the engine.

- Remove the drain plug of the hydraulic tank and drain the old oil into a bowl.
- Install the drain plug.

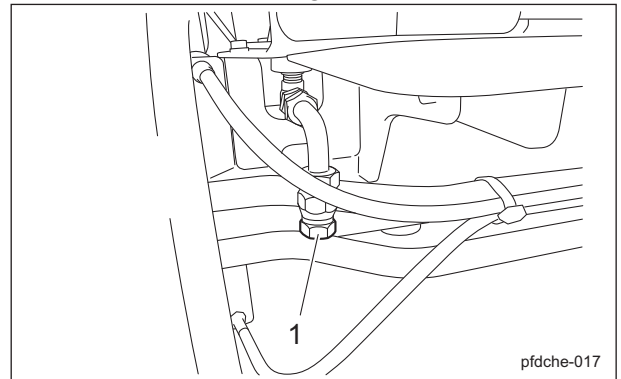

Change of Hydraulic Oil\_001

1	Drain plug
---	------------

- Remove the tank cover.
- Open the tank cap, and then pour new oil from the fill port until the oil level reaches the middle of the oil gauge on the hydraulic tank. The hydraulic tank capacity is approximately 30.3 dm<sup>3</sup> (30.3 L).

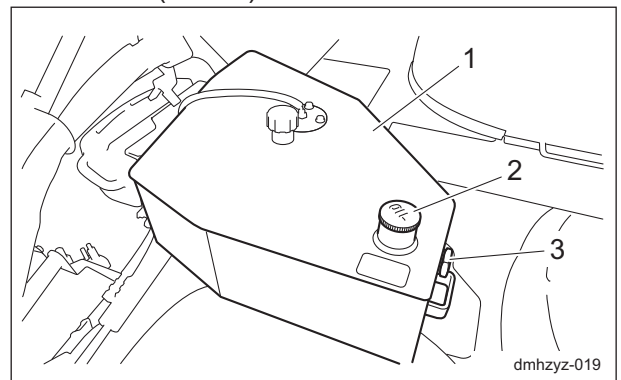

Change of Hydraulic Oil\_002

1	Hydraulic tank
2	Tank cap
3	Oil gauge

- Tighten the tank cap securely.
- Start the engine, raise and lower the mower units, and turn the steering wheel left and right. Move forward and reverse repeatedly several times.
- Raise the mower units and maintain that position on a level surface, and then check to see if the oil level is at the middle of the oil gauge. If necessary, supply oil.
- Check underneath the machine for hydraulic oil leakage.
- Install the tank cover.

# Maintenance

## Change of Hydraulic Oil Filter

### Change of Hydraulic Oil Line Filter

**Caution**

Be careful with hot oil, which could cause burns if it contacts your skin.

**Important**

When replacing the hydraulic oil filter, be sure to drain the oil into a container and discard it in accordance with local laws and regulations.

**Important**

If the hydraulic oil emulsifies or if it becomes even slightly less transparent, change the oil immediately.

**Important**

Use Shell Tellus S2M46 (or equivalent) as hydraulic oil.

1. On a level surface, lower the mower units, and then stop the engine.
2. Loosen the filter case and remove it.  
Note:  
Use a 24 mm socket wrench.

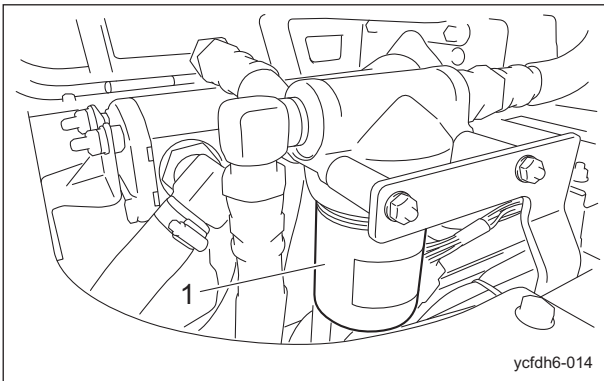

Change of Hydraulic Oil Line Filter\_001

1	Filter case
---	-------------

3. Remove the old filter cartridge.

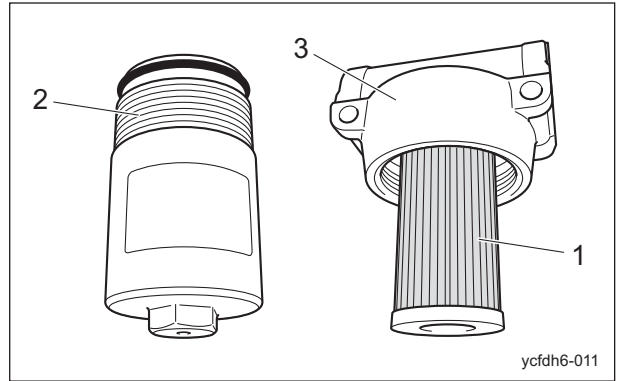

Change of Hydraulic Oil Line Filter\_002

1	Filter cartridge
2	Filter case
3	Body

4. Lightly coat the O-ring of the new filter cartridge with hydraulic oil, and then install the cartridge.

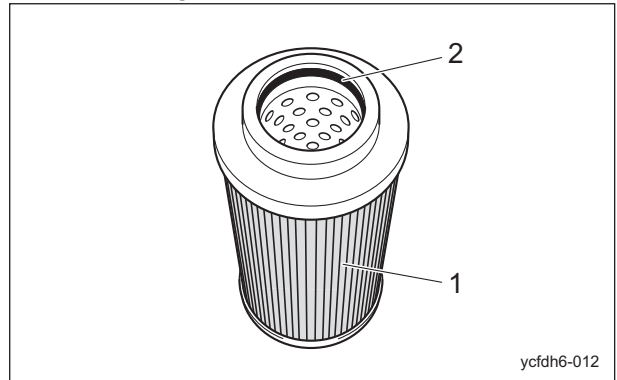

Change of Hydraulic Oil Line Filter\_003

1	Filter cartridge
2	O-ring

5. Clean the inside of the filter case.
6. Make sure that there is no damage to the O-ring of the filter case, and then lightly coat the O-ring with hydraulic oil.

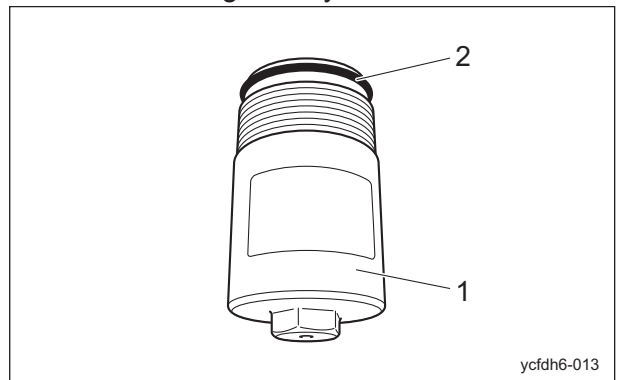

Change of Hydraulic Oil Line Filter\_004

1	Filter case
2	O-ring

7. Install the filter case onto the body, firmly hand-tighten it, and then tighten it to 25 to 35 N·m (254.93 to 356.90 kgf-cm).

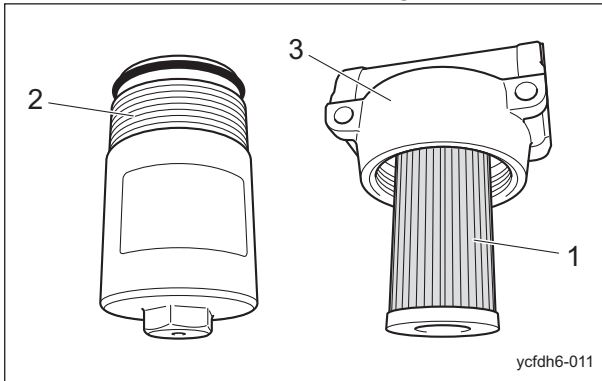

Change of Hydraulic Oil Line Filter\_005

1	Filter cartridge
2	Filter case
3	Body

8. Supply hydraulic oil until it reaches the specified level.  
"Supply of Hydraulic Oil" (Page 4-7)
9. Start the engine, and then after the hydraulic oil has warmed up, stop the engine.
10. Check underneath the machine for hydraulic oil leakage.

## Change of Hydraulic Suction Filter

**Caution**

Be careful with hot oil, which could cause burns if it contacts your skin.

**Important**

When replacing the hydraulic oil filter, be sure to drain the oil into a container and discard it in accordance with local laws and regulations.

**Important**

If the hydraulic oil emulsifies or if it becomes even slightly less transparent, change the oil immediately.

**Important**

Use Shell Tellus S2M46 (or equivalent) as hydraulic oil.

1. On a level surface, lower the mower units, and then stop the engine.
2. Remove the filter protection plate.

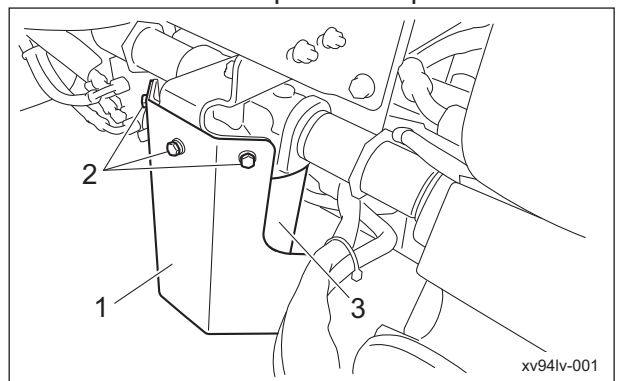

Change of Hydraulic Suction Filter\_001

1	Filter protection plate
2	Bolt
3	Filter cartridge

3. Remove the old filter cartridge.
4. Lightly coat the packing of the new filter cartridge with hydraulic oil, and then install the cartridge.

# Maintenance

5. Firmly tighten the filter cartridge by hand so that the packing contacts the mounting surface.

Then, tighten it an additional 1/2 turn.

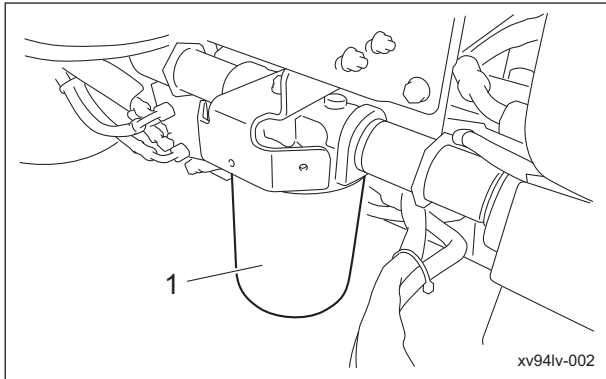

Change of Hydraulic Suction Filter\_002

1	Cartridge filter
---	------------------

6. Supply hydraulic oil until it reaches the specified level.  
"Supply of Hydraulic Oil" (Page 4-7)
7. Start the engine, and then after the hydraulic oil has warmed up, stop the engine.
8. Check underneath the machine for hydraulic oil leakage.
9. Install the filter protection plate.

## Change of Air Cleaner

A contaminated air cleaner element may cause malfunction of the engine.

To maximize the life of the engine, replace the air cleaner element at the appropriate times.

- The timing for replacing the air cleaner element is described below.
  - Replace the air cleaner element in accordance with the Maintenance Schedule.
  - If it is significantly contaminated, replace it, even if the hours of operation do not exceed the specified time.
- Replace the air cleaner element by following the same steps as for cleaning the air cleaner.  
"Cleaning of Air Cleaner" (Page 4-9)

## Change of Engine Oil

### ⚠ Caution

Be careful with hot oil, which could cause burns if it contacts your skin.

### Important

When changing the engine oil, be sure to drain it into a container and discard it in accordance with local laws and regulations.

### Important

Be sure to use engine oil that is classified as JASO DH-2 or API Service Grade CJ-4, with an SAE Viscosity that is appropriate for the operating environment (ambient temperature).

### Important

Securely tighten the oil level gauge and oil filler cap.

Change the engine oil more frequently if it is contaminated and especially if you use the machine in dusty areas or operate the engine at high loads or in high temperatures.

- Follow the steps below to remove the old engine oil.
  - Start and run the engine to warm up the engine oil.
  - With the machine on a level surface, stop the engine.
  - Remove the drain plug, and then drain the old engine oil into a container.

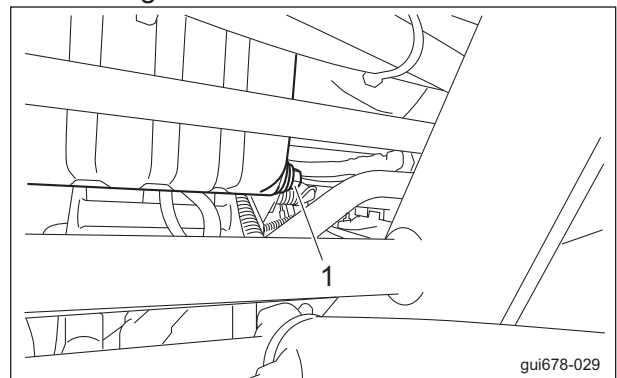

Change of Engine Oil\_001

1	Drain plug
---	------------

- Re-place the drain plug.

- Remove the oil filler cap, and then supply new engine oil until the oil reaches a level in between the upper and lower limit lines on the oil level gauge.  
The engine oil quantity is approximately 6.7 dm<sup>3</sup> (6.7 L).
- Securely install the oil filler cap.

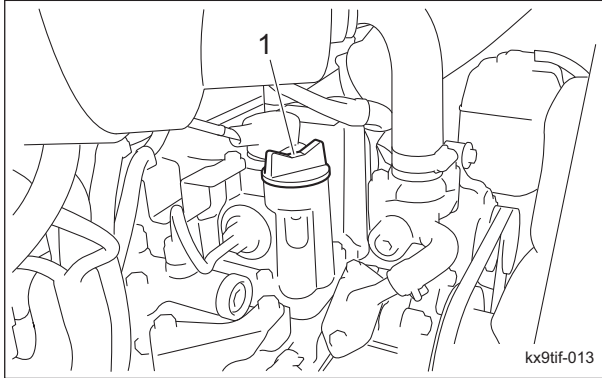

Change of Engine Oil\_002

1	Oil filler cap
---	----------------

- It will take a while for the supplied engine oil to descend into the oil pan.  
Check the oil level again 10 to 20 minutes after replenishment.
- Check underneath the machine for oil leakage.

### Change of Engine Oil Filter

#### ⚠ Caution

Be careful with hot oil, which could cause burns if it contacts your skin.

#### Important

When replacing the engine oil filter, be sure to drain the engine oil into a container and discard it in accordance with local laws and regulations.

#### Important

Be sure to use engine oil that is classified as JASO DH-2 or API Service Grade CJ-4, with an SAE Viscosity that is appropriate for the operating environment (ambient temperature).

#### Important

Securely tighten the oil level gauge and oil filler cap.

- With the filter wrench, remove the old filter cartridge.

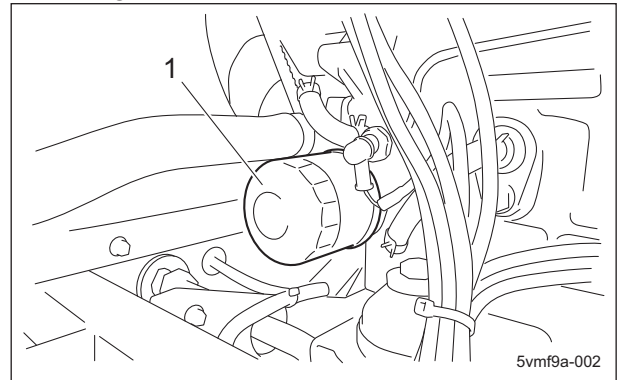

Change of Engine Oil Filter\_001

1	Filter cartridge
---	------------------

- Lightly coat the packing of the new filter cartridge with engine oil.
- Hand-tighten the filter cartridge until the packing contacts the sealing surface, and then firmly hand-tighten (without using a filter wrench).
- Supply engine oil until it reaches the specified level.  
"Supply of Engine Oil" (Page 4-12)
- Start the engine, and then stop it after 10 to 20 minutes.
- Make sure that there is no oil leakage at the sealing surface of the filter cartridge.
- Check the engine oil level.  
If it is low, supply engine oil until it reaches the specified level.

# Maintenance

## Change of Fuel Filter

### Important

During installation, prevent contamination with dirt or dust.

If the fuel is contaminated with dirt, dust, etc., the fuel injection pump and injection nozzle will become worn.

Since the fuel filter is a cartridge, it cannot be disassembled or cleaned.

If dust or dirt accumulates in the fuel filter, the fuel flow will become insufficient.

Replace the fuel filter at the appropriate times.

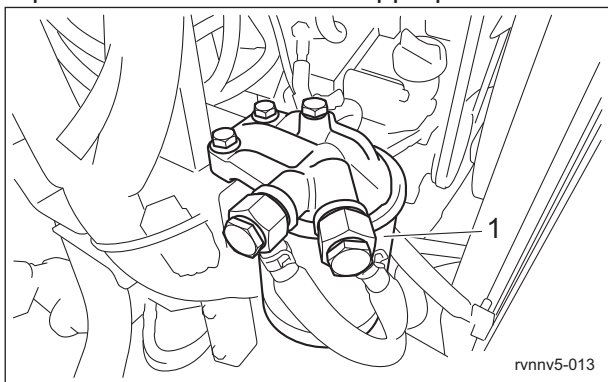

Change of Fuel Filter\_001

1	Fuel filter
---	-------------

1. Follow the steps below to replace the fuel filter.

[1] Using a filter wrench, remove the fuel filter cartridge.

[2] Lightly coat the packing of the new cartridge with fuel, and then firmly hand-tighten the cartridge, without using the filter wrench.

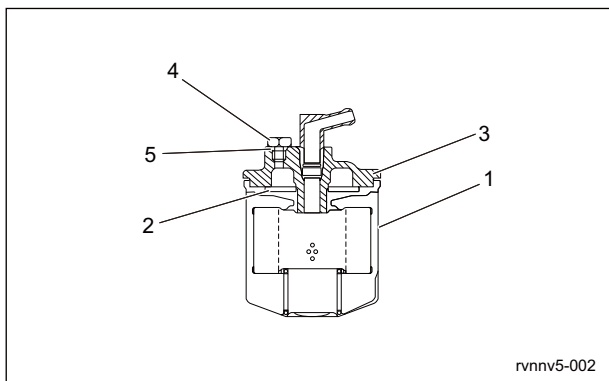

Change of Fuel Filter\_002

1	Cartridge
2	Packing
3	Cover
4	Air-bleeding plug
5	O-ring

2. When the ignition key is set to the "ON" position and the fuel pump is operated after replacement, air bleeding will occur automatically.

If the automatic air bleeding is not available, remove air manually.

## Change of Fuse

**Important**

When performing maintenance on the electrical system, be sure to remove the negative battery wire.

**Important**

If a fuse blows, a short may have occurred within the electrical circuit. Check for the cause, such as faulty terminal connections, damaged wiring or terminals, or incorrect wiring.

**Important**

For fuse replacement, clean the fuse mounting area with use of compressed air before mounting the fuse.

### Fuse Box

The fuse box includes spare fuses and tools.

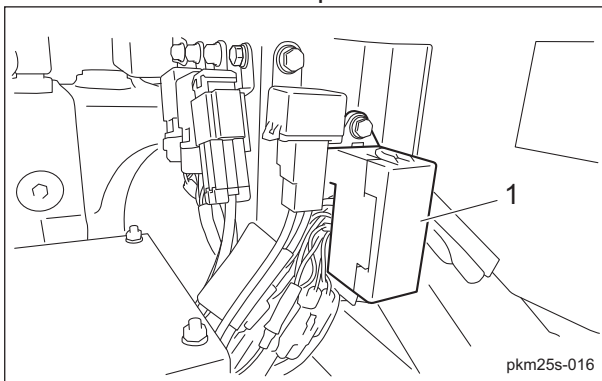

Fuse Box\_001

1	Fuse box
---	----------

The machine uses a mini fuse for automobiles. Replace an old fuse with a new fuse of the specified capacity.

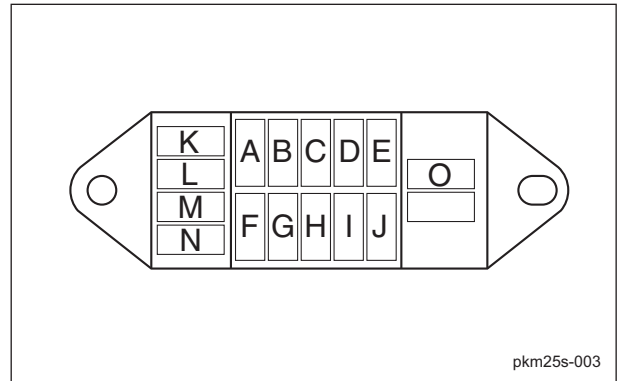

pkm25s-003

Fuse Box\_002

A	5 A	Starter relay (CB1a-12V), alternator
B	5 A	Ignition SW (to E/G ECU)
C	5 A	Water temperature warning buzzer, DPF auto regeneration inhibit SW, DPF parked regeneration SW, initial reset board, warning lamp, DPF regeneration lamp, CAN monitor
D	15 A	#2 · #3 up/down SOL relay, #4 down detection relay, #4 proximity sensor, #5 proximity sensor, operation lever proximity sensor (UP), operation lever proximity sensor (DOWN), traveling pedal position detection proximity sensor, engine stop signal (to E/G ECU), relay box L, #2 · #3 up/down SOL, #2 · #3 up/down delay timer, overload detection relay, UP delay off relay
E	15 A	Oil level warning buzzer, P brake SW signal (to E/G ECU), starter relay (MR5A411A1K), #2 proximity sensor, #1 proximity sensor, neutral proximity sensor, P brake SW relay, P brake proximity sensor, relay box R
F	-	(Unused)
G	5 A	Start signal (to E/G ECU)
H	-	(Unused)
I	5 A	Reel rotation SW relay, rotation detection relay, lapping SW relay, oil level SW, engine stop relay, seat OFF delay timer
J	5 A	Diagnostic connector
K	5 A	Spare
L	5 A	
M	15 A	
N	15 A	
O		Tool

# Maintenance

## Fusible Link

Fuse capacities of the fusible links are 30 A, 50 A and 80 A.

- 30 A: ECU
- 50 A: accessories
- 80 A: Battery, Heater relay

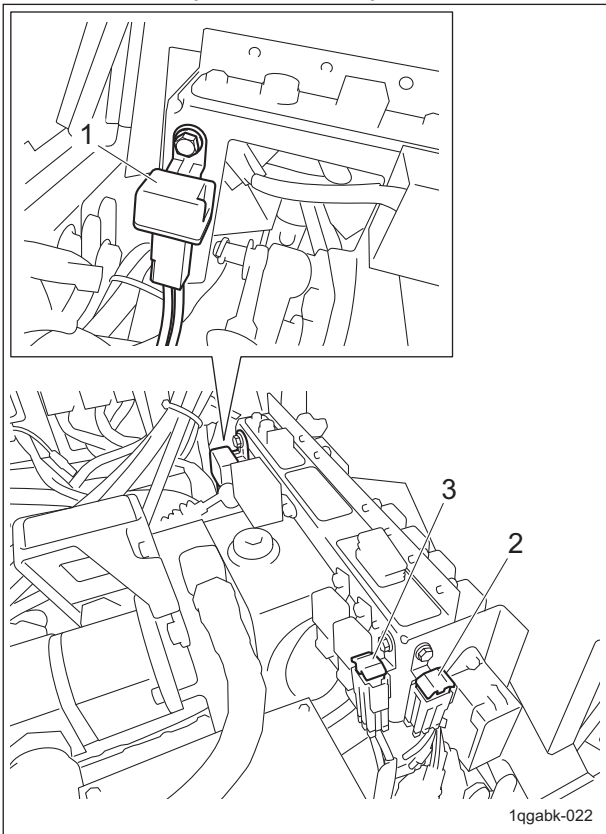

Fusible Link\_001

1	Fusible link (30 A)
2	Fusible link (50 A)
3	Fusible link (80 A)

## Fuse

The fuse in the main harness is for USB socket and LED work lamp. Depending on the specifications, the LED work lamp may not be available. The capacity of the mini blade fuse is 15 A.

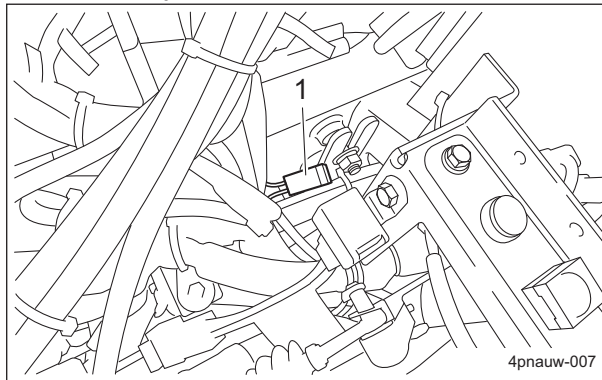

Fuse\_001

1	Mini blade fuse
---	-----------------

The fuse in the heater relay harness is for intake heater. The capacity of the MIDI fuse is 125 A.

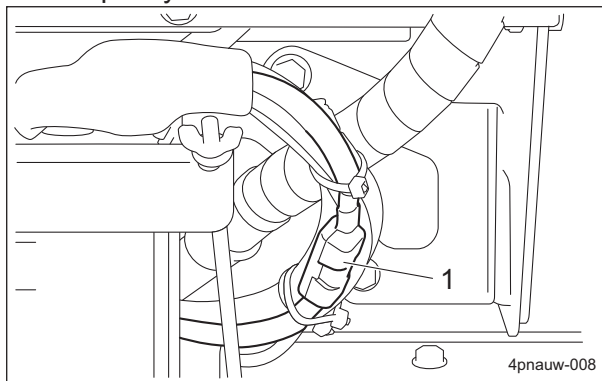

Fuse\_002

1	MIDI fuse
---	-----------



## EU Declaration of Conformity

### Product Identification

Product : Lawnmower  
Brand-Name : BARONESS  
Type : LM551B  
Starting Serial No. : **30028**  
Measured Sound Power Level : LWA 101.66 dB  
Guaranteed Sound Power Level : LWA 103 dB  
Manufacturer Name : Kyoeshisa Co., Ltd.  
Address : 1-26 Miyuki-cho, Toyokawa, Aichi-pref., Japan

### Conforms to the following Directives

2006/42/EC Machinery (MD)  
2014/30/EU Electromagnetic compatibility (EMC)  
2000/14/EC Noise emissions from outdoor equipment

### We have been designed and manufactured under the following specifications

ISO 12100 : 2010 (2006/42/EC)  
ISO 5395-1 : 2013 (2006/42/EC)  
ISO 5395-3 : 2013 (2006/42/EC)  
ISO 14982 : 1998 (2014/30/EU)

### Keeper of Technical Documentation

Name : Kyoeshisa Co., Ltd.  
Address : 1-26 Miyuki-cho, Toyokawa, Aichi-pref., Japan

### Compiler of the technical file (2006/42/EC)

Name : Friedrich E. Barthels Nachf. Glockzin KG (GmbH & Co.)  
Address : Gerhard-Falk-Str. 1 21035 Hamburg Germany

### Conformity assessment procedures

Internal production control : Module A (2006/42/EC)  
EC-type examination : Module B (2014/30/EU)  
Internal control of production with assessment of technical documentation and periodical checking (2000/14/EC)

### Involved Notified Body (2000/14/EC)

Name : TÜV SÜD Industrie Service GmbH  
Address : Westendstraße 199 80686 München  
Certificate : Notified Body NB0036 according 2000/14/EC

Place : Japan

Date : 18 November 2021 (18 / 11/ 2021)

Signature :

Name : Akio Hayashi

Position : Quality Dept. Director

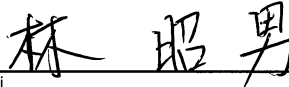

Traduction de la Déclaration de Conformité originale (fr)

## Déclaration de conformité UE

### Identification du produit

Produit : Tondeuse à gazon  
Fabriquant : BARONESS  
Type : LM551B  
Numéro de série de début : **30028**  
Niveau de puissance acoustique mesuré : LwA 101.66 dB  
Niveau de puissance acoustique garanti : LwA 103 dB  
Fabricant Nom : Kyoeshisa Co., Ltd.  
Adresse : 1-26, Miyuki-cho, Toyokawa, préfecture d'Aichi, Japon

### Conforme aux directives suivantes :

2006/42/CE Machine (MD)  
2014/30/UE Compatibilité électromagnétique (CEM)  
2000/14/CE Émissions sonores de l'équipement de plein air

### Conception et fabrication en respect des spécifications suivantes :

ISO 12100 : 2010 (2006/42/CE)  
ISO 5395-1 : 2013 (2006/42/CE)  
ISO 5395-3 : 2013 (2006/42/CE)  
ISO 14982 : 1998 (2014/30/UE)

### Fiche technique

Marque : Kyoeshisa Co., Ltd.  
Adresse de la marque : 1-26, Miyuki-cho, Toyokawa, préfecture d'Aichi, Japon

### Compilateur de la fiche technique (2006/42/CE)

Nom : Friedrich E. Barthels Nachf. Glockzin KG (GmbH & Co.)  
Adresse : Gerhard-Falk-Str. 1 21035 Hambourg Allemagne

### Procédures d'évaluation de la conformité

Contrôle de production interne : module A (2006/42/CE)  
Examen de type CE : module B (2014/30/UE)  
Contrôle interne de la production avec évaluation de la fiche technique et vérification périodique (2000/14/CE)

### Organisme notifié impliqué (2000/14/CE)

Nom : TÜV SÜD Industrie Service GmbH  
Adresse : Westendstraße 199 80686 München  
N° de certificat : Notified Body NB0036 according 2000/14/EC

**Declaración de conformidad de la UE**

## Identificación del producto

Producto: Cortacésped  
 Marca: BARONESS  
 Tipo: LM551B  
 N.º de serie inicial: **30028**  
 Nivel de potencia sonora medido: LWA 101.66 dB  
 Nivel de potencia sonora garantizado: LWA 103 dB  
 Fabricante Nombre: Kyoisha Co., Ltd.  
 Dirección: 1-26 Miyuki-cho, Toyokawa, Aichi-pref., Japón

## Cumple las siguientes Directivas

2006/42/CE Maquinaria (MD)  
 2014/30/UE Compatibilidad electromagnética (EMC)  
 2000/14/CE Emisiones sonoras de máquinas de uso al aire libre

## Se ha diseñado y fabricado utilizando las siguientes especificaciones

ISO 12100 : 2010 (2006/42/CE)  
 ISO 5395-1 : 2013 (2006/42/CE)  
 ISO 5395-3 : 2013 (2006/42/CE)  
 ISO 14982 : 1998 (2014/30/UE)

## Documentación técnica

Nombre del responsable: Kyoisha Co., Ltd.  
 Dirección del responsable: 1-26 Miyuki-cho, Toyokawa, Aichi-pref., Japón

## Compilador del archivo técnico (2006/42/CE)

Nombre: Friedrich E. Barthels Nachf. Glockzin KG (GmbH & Co.)  
 Dirección: Gerhard-Falk-Str. 1 21035 Hamburgo Alemania

## Procedimientos de evaluación de conformidad

Control de fabricación interno: Módulo A (2006/42/CE)  
 Examen de tipo CE: Módulo B (2014/30/UE)  
 Control interno de fabricación con evaluación de documentación técnica y comprobaciones periódicas (2000/14/CE)

## Organismo notificado implicado (2000/14/CE)

Nombre: TÜV SÜD Industrie Service GmbH  
 Dirección: Westendstraße 199 80686 München  
 Certificado: Notified Body NB0036 according 2000/14/EC

**EU-Konformitätserklärung**

## Produktbeschreibung

Produkt: Rasenmäher  
 Marke: BARONESS  
 Modell: LM551B  
 Startseriennummer: **30028**  
 Gemessener Schalleistungspegel: LWA 101.66 dB  
 Garantierter Schalleistungspegel: LWA 103 dB  
 Hersteller Name: Kyoisha Co., Ltd.  
 Adresse: 1-26 Miyuki-cho, Toyokawa, Aichi-pref., Japan

## Entspricht den folgenden Richtlinien

2006/42/EG Maschinenrichtlinie  
 2014/30/EU Elektromagnetische Verträglichkeit (EMV)  
 2000/14/EG Geräuschemission von im Freien betriebenen Geräten

## Unter Anwendung der folgenden Bestimmungen entwickelt und hergestellt

ISO 12100 : 2010 (2006/42/EG)  
 ISO 5395-1 : 2013 (2006/42/EG)  
 ISO 5395-3 : 2013 (2006/42/EG)  
 ISO 14982 : 1998 2014/30/EU)

## Technische Dokumentation

Name des Halters: Kyoisha Co., Ltd.  
 Adresse des Halters: 1-26 Miyuki-cho, Toyokawa, Aichi-pref., Japan

## Technische Unterlagen erstellt von (2006/42/EG)

Name: Friedrich E. Barthels Nachf. Glockzin KG (GmbH & Co.)  
 Adresse: Gerhard-Falk-Str. 1 21035 Hamburg Deutschland

## Konformitätsbewertungsverfahren

Interne Produktionskontrolle : Modul A (2006/42/EG)  
 EG-Baumusterprüfung : Modul B (2014/30/EU)  
 Interne Produktionskontrolle mit Bewertung der technischen Unterlagen und regelmäßiger Überprüfung (2000/14/EG)

## Beteiligte benannte Stelle (2000/14/EG)

Name: TÜV SÜD Industrie Service GmbH  
 Adresse: Westendstraße 199 80686 München  
 Bescheinigung: Notified Body NB0036 according 2000/14/EC

**EU-försäkran om överensstämmelse**

## Produktidentifikation

Produkt : Gräsklippare  
 Märke: BARONESS  
 Typ: LM551B  
 Serienummer startar på: **30028**  
 Uppmätt ljudeffektnivå: LWA 101.66 dB  
 Garanterad ljudeffektnivå: LWA 103 dB  
 Tillverkare Namn: Kyoisha Co., Ltd.  
 Adress: 1-26 Miyuki-cho, Toyokawa, Aichi-pref., Japan

## Uppfyller följande direktiv

2006/42/EG Maskindirektivet  
 2014/30/EU Elektromagnetisk kompatibilitet (EMC)  
 2000/14/EG Bulleremission från utomhusutrustning

## Följande kravspecifikationer har följts vid konstruktion och tillverkning

ISO 12100 : 2010 (2006/42/EG)  
 ISO 5395-1 : 2013 (2006/42/EG)  
 ISO 5395-3 : 2013 (2006/42/EG)  
 ISO 14982 : 1998 (2014/30/EU)

## Teknisk dokumentation

Innehavarens namn: Kyoisha Co., Ltd.  
 Innehavarens adress: 1-26 Miyuki-cho, Toyokawa, Aichi-pref., Japan

## Den tekniska filen(2006/42/EG) har tagits fram av

Namn: Friedrich E. Barthels Nachf. Glockzin KG (GmbH & Co.)  
 Adress: Gerhard-Falk-Str. 1 21035 Hamburg Tyskland

## Förfarande för bedömning av överensstämmelse

Intern produktionskontroll: Modul A (2006/42/EG)  
 EG-typprovning: Modul B (2014/30/EU)  
 Intern kontroll av produktion med fastställande av teknisk dokumentation och periodiska kontroller (2000/14/EG)

## Anmält organ (2000/14/EG)

Namn: TÜV SÜD Industrie Service GmbH  
 Adress: Westendstraße 199 80686 München  
 Certifikat : Notified Body NB0036 according 2000/14/EC

**EU-overensstemmelseserklæring**

## Produktidentificering

Produkt : Plæneklipper  
 Mærkenavn: BARONESS  
 Type: LM551B  
 Startende serienr.: **30028**  
 Målt lydtekniveau: LWA 101.66 dB  
 Garanteret lydtekniveau: LWA 103 dB  
 Producent Navn: Kyoisha Co., Ltd.  
 Adresse: 1-26 Miyuki-cho, Toyokawa, Aichi-præf.,Japan

## Er i overensstemmelse med følgende direktiver

2006/42/EF Maskineri (MD)  
 2014/30/EU Elektromagnetisk kompatibilitet (EMC)  
 2000/14/EF Støjmissioner fra udendørs udstyr

## Vi har designet og produceret under følgende specifikationer

ISO 12100 : 2010 (2006/42/EF)  
 ISO 5395-1 : 2013 (2006/42/EF)  
 ISO 5395-3 : 2013 (2006/42/EF)  
 ISO 14982 : 1998 (2014/30/EU)

## Indehaver af teknisk dokumentation

Navn: Kyoisha Co., Ltd.  
 Adresse: 1-26 Miyuki-cho, Toyokawa, Aichi-præf.,Japan

## Kompilator af den tekniske fil (2006/42/EF)

Namn: Friedrich E. Barthels Nachf. Glockzin KG (GmbH & Co.)  
 Adresse: Gerhard-Falk-Str. 1 21035 Hamborg Tyskland

## Procedurer for overensstemmelsesvurdering

Intern produktionskontrol : Modul A (2006/42/EF)  
 EF-typeafprøvning : Modul B (2014/30/EU)  
 Intern fabrikkationskontrol med vurdering af teknisk dokumentation og periodisk kontrol (2000/14/EF)

## Berørt bemyndiget organ (2000/14/EF)

Navn: TÜV SÜD Industrie Service GmbH  
 Adresse: Westendstraße 199 80686 München  
 Certifikat: Bemyndiget organ NB0036 ifølge 2000/14/EF

**BARONESS**<sup>®</sup>  
Quality on Demand

 **KYOEISHA CO., LTD.**  
Head Office 1-26, Miyuki-cho, Toyokawa-city, Tel :+81-533-84-1390  
Aichi-pref, 442-8530 JAPAN Fax:+81-533-84-1220