

FS900

Riding Sweeper

Owner's Operating Manual

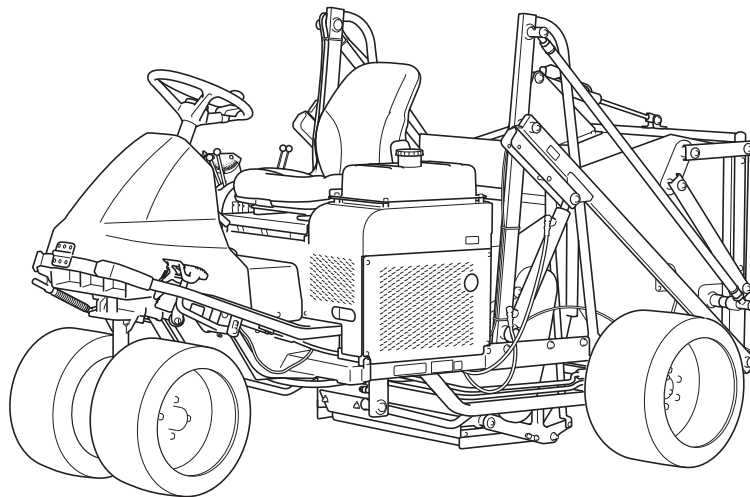

Serial No. FS900 : 11059-

"Required reading"
Read this manual before using the machine.

BARONESS[®]
Quality on Demand

Ver.2.2

Greeting

Thank you for purchasing the Baroness product.
This manual describes the proper handling,
adjustment, and inspection of your product.
We hope you will use the product safely, and take
advantage of its best performance.

Read this manual carefully to ensure that you thoroughly understand how to properly operate and maintain the product, and to avoid causing injury to yourself or others.

The operator is responsible for operating the product properly and safely.

Maintenance service for this machine should be performed by a mechanic with expertise.

If you have any questions concerning maintenance or genuine parts, please contact a Baroness dealer or Kyoisha.





When making inquiries about the product, please specify the product's model designation and serial number.

When loaning or transferring the product, please also provide this manual together with the product.

Kyoisha Co., Ltd.

Warning Symbols

This manual uses the following warning symbols for handling precautions that are important for your safety.

 <p style="text-align: center;">696cq5-001</p>	<p>Warning symbol</p>
<p>This symbol indicates the articles regarding “Danger,” “Warning,” or “Caution.” Those articles describe important safety precautions and so read them carefully to understand completely before operating the machine. Failure to adequately follow these safety precautions may cause an accident.</p>	
<p> Danger</p> <p>This symbol indicates that serious injury or death will occur if the warning is ignored.</p> <p> Warning</p> <p>This symbol indicates that serious injury or death may occur if the warning is ignored.</p> <p> Caution</p> <p>This symbol indicates that injury or damage to property may occur if the warning is ignored.</p> <p>Important</p> <p>This symbol indicates precautions on the mechanism of the machine.</p>	

Introduction

Precautionary Statement

 **Caution**

The information described in this manual is subject to change for improvement without prior notice.

When replacing parts, be sure to use genuine Baroness parts or parts designated by Kyoisha.

Note that the Baroness product warranty may not apply to defects caused by the use of parts from other companies.

Prior to use, carefully read the following manuals to thoroughly understand the contents for safe and correct operation.

- Baroness Owner's Operating Manual
- The Engine's Owner's Manual
- The Battery's Owner's Manual

Purpose

This product is intended for sweeping at golf courses.

Do not use this product in any way other than its intended purpose, and do not modify this product.

Operating this product for other purposes and modifying it may be very dangerous and may cause damage to the product.

In addition, this product is not authorized for operation as a special motor vehicle. Do not operate it on public roads.

Safety	Page 1-1
Safe Operating Practices	Page 1-2
Disposal	Page 2-1
Recycle and Waste Disposal	Page 2-2
Product Overview	Page 3-1
Specifications	Page 3-2
Names of Each Section	Page 3-4
Regulation Decals	Page 3-4
Safety Signs and Instruction Signs	Page 3-5
Handling Instructions	Page 4-1
Inspections	Page 4-2
Daily Check List	Page 4-2
Tightening Torques	Page 4-11
Adjustment before Work	Page 4-15
Procedure to Start/Stop Engine	Page 4-17
Operation Method	Page 4-18
Instruments	Page 4-29
Angle Meter	Page 4-29
Move	Page 4-29
Operations	Page 4-31
Transporting	Page 4-33
Storage	Page 4-33
Maintenance	Page 5-1
Maintenance Precautions	Page 5-2
Maintenance Schedule	Page 5-3
Jacking Up The Machine	Page 5-5
Greasing	Page 5-6
Lubrication	Page 5-9
Maintenance Work	Page 5-10

FS900

Contents

Safe Operating Practices Page 1-2

Training Page 1-2

Preparation Page 1-2

Operation Page 1-3

Maintenance Page 1-4

Storage Page 1-4

Safety

Failure to adequately follow these safety precautions may cause an accident resulting in injury or death.

Danger

This product is designed to ensure safe operation and has been tested and inspected thoroughly before shipment from the factory. The product is equipped with safety devices to prevent accidents.

However, whether the product demonstrates its original performance level depends on the manner in which it is operated and handled, as well as the manner in which it is managed on a daily basis.

Inappropriate use or management of the product may result in injury or death.

Observe the following safety instructions to ensure safe operation.

Safe Operating Practices

Training

1. Read this manual and other training material carefully.

Be familiar with the controls, safety signs, and the proper use of the equipment.

2. If the operator or mechanic can not read the language used in this manual, it is the owner's responsibility to explain this material to them.

3. All operators and mechanics should seek and obtain professional and practical instruction.

The owner is responsible for training the users.

Such instruction should emphasize:

- [1] The need for care and concentration when working with ride-on machines.

- [2] Control of a ride-on machine sliding on a slope will not be regained by the application of the brake.

The main reasons for loss of control are

- Insufficient wheel grip
- Being driven too fast
- Inadequate braking
- The type of machine is unsuitable for its task
- Lack of awareness of the effect of ground conditions, especially slopes
- Incorrect hitching and load distribution

4. Never allow children or people unfamiliar with these instructions to use or service the machine.

Local regulations may restrict the age of the operator.

5. The owner/user can prevent and is responsible for accidents or injuries occurring to themselves, other people, or property.
6. Keep in mind that the owner, operator, and mechanic are responsible for accidents or hazards occurring to other people or their property.
7. You can find additional safety information where needed throughout this manual.
8. Determine the left and right sides of the machine from the normal operating position.

Preparation

1. Evaluate the terrain to determine what accessories and attachments are needed to properly and safely perform the job. Only use accessories and attachments approved by the manufacturer.
2. While operating, always wear substantial footwear, long trousers, hard hat, safety glasses, mask, and ear protection. Long hair, loose clothing, or jewelry may get tangled in moving parts. Do not operate the equipment when barefoot or wearing open sandals.
3. Inspect the area where the equipment is to be used and remove all objects such as rocks, toys and wire which can be thrown by the machine.
4. Keep children out of the operating area and under the watchful care of a responsible adult other than the operator.
5. Exercise care in the handling of fuel.

Warning

Fuel is highly flammable.

Take the following precautions:

- [1] Store fuel in containers specifically designed for this purpose.
- [2] Add fuel before starting the engine. Never remove the cap of the fuel tank or add fuel while the engine is running or when the engine is hot.
- [3] Refuel outdoors only and do not smoke while refueling.

- [4] If fuel is spilled, do not attempt to start the engine but move the machine away from the area of spillage and avoid creating any source of ignition until petrol vapours have dissipated;
- [5] Replace all fuel tanks and container caps securely.
- 6. Check that operator's presence controls, safety switches and shields are attached and functioning properly.
Do not operate unless they are functioning properly.
- 7. If the brake operation is faulty, be sure to adjust or repair them before operating the machine.
- 8. Replace faulty mufflers.

Operation

- 1. Do not operate the machine under the influence of alcohol or drugs.
- 2. Do not operate the engine in a confined space where dangerous carbon monoxide fumes can collect.
- 3. Be sure all drives and shift are in neutral and parking brake is engaged before starting engine.
Only start engine from the operator's position.
Use seat belts if provided.
- 4. Do not change the engine governor settings or overspeed the engine.
Operating the engine at excessive speed may increase the hazard of personal injury.
- 5. Never operate the machine with damaged guards, shields, or without safety protective devices in place.
Be sure all interlocks are attached, adjusted properly, and functioning properly.
- 6. Keep hands and feet away from the rotating parts.
- 7. Do not carry passengers.
- 8. Never operate while people, especially children, or pets are nearby.
- 9. Only operate in good light, keeping away from holes and hidden hazards.
- 10. Do not operate the machine when there is the risk of lightning.
- 11. Do not stop or start suddenly.
- 12. Look behind and down before backing up to be sure of a clear path.

- 13. Slow down and use caution when making turns and crossing roads and sidewalks.
- 14. Use care when approaching blind corners, shrubs, trees, or other objects that may obscure vision.
- 15. Do not take your eyes off the road ahead.
Do not operate the machine with no hands.
- 16. Remember there is no such thing as a safe slope.
Travel on grass slopes requires particular care.
To guard against overturning, follow these instructions.
 - [1] Do not stop or start suddenly when going up or downhill.
 - [2] Engage clutch slowly, always keep machine in gear, especially when traveling downhill.
 - [3] Machine speeds should be kept low on slopes and during turns.
 - [4] Stay alert for humps and hollows and other hidden hazards.
- 17. Never use the machine on a slope with an angle of gradient that is greater than that specified or in a place where there is a danger of the machine slipping.
- 18. Disengage drive to the mechanical equipment section, when other than operating.
- 19. Do the following before leaving the operator's position.
 - [1] Stop on level ground.
 - [2] Disengage the all drives.
 - [3] Lower the bucket.
 - [4] Set the parking brake.
 - [5] Stop the engine.
 - [6] Remove the ignition key.
- 20. Stop the engine in the following conditions.
 - [1] Before refuelling.
 - [2] Before making height or depth adjustment unless adjustment can be made from the operator's position.
 - [3] Before clearing blockages.
 - [4] Before checking, cleaning or working on the machine.
 - [5] After striking a foreign object or if an abnormal vibration occurs.
Inspect the machine for damage and make repairs before restarting and operating the equipment.

Safety

21. Reduce the throttle setting during engine run-out.
22. Take care when loading or unloading the machine into a trailer or a truck.
Load or unload the machine in a flat and safe place.
Before loading or unloading, set the parking brake on the truck or trailer, stop the engine, and chock the wheels.
When transporting the machine on a truck or a trailer, set the parking brake, stop the engine, and fasten the machine to the truck with a rope or other suitable restraining device that has sufficient strength.
When using a running board, select one with sufficient strength, length, and width and that will not cause the machine to slip.
23. Close the fuel valve before transporting the machine.
8. Keep hands and feet away from moving parts.
If possible, do not make adjustments with the engine running.
9. Make sure that parts such as wires are not touching each other and that their covers have not come off.
10. Keep all parts in good working condition and all hardware tightened.
Replace all worn or damaged decals.
11. Keep all nuts, bolts and screws tight to be sure the equipment is in safe working condition.
12. Carefully release pressure from components with stored energy.
13. Be sure to depressurize the hydraulic system before performing maintenance operations on it such as removing hydraulic equipment.
14. Check whether line connectors in the hydraulic system are properly tightened.
Before applying hydraulic pressure, check the connections of the hydraulic pressure lines and the condition of the hoses.
15. When checking the hydraulic circuit for pinhole leaks or oil leakage from nozzles, do not use your hands.
Use items such as paper or corrugated cardboard to find leakage points.
Be extremely careful with high-pressure oil as it may pierce your skin, resulting in an injury.
If fluid is injected into the skin it must be surgically removed within a few hours by a doctor familiar with this form of injury or gangrene may result.

Maintenance

1. Never allow untrained personnel to service machine.
2. Implement the following work before adjusting, cleaning or repairing.
 - [1] Stop the machine on level ground.
 - [2] Disengage drive to the mechanical equipment section.
 - [3] Lower the brush section and the bucket.
 - [4] Set the parking brake.
 - [5] Stop the engine.
 - [6] Remove the ignition key.
 - [7] Wait for all movement to stop.
3. Allow the engine/muffler to cool before checking/maintenance.
4. To reduce the fire hazard, keep hot parts such as the engine and silencer/muffler, battery compartment and fuel storage area free of grass, leaves, or excessive grease.
Clean up oil or fuel spillage.
5. Appropriately manage and correctly use the tools necessary for servicing or adjusting the machine.
6. Disconnect battery before making any repairs.
Disconnect the negative terminal first and the positive last.
Reconnect positive first and negative last.
7. Use jack stands to support components when required.

Storage

16. Charge batteries in an open well ventilated area, away from spark and flames.
Unplug charger before connecting or disconnecting from battery.
Wear protective clothing and use insulated tools.
17. If the fuel tank has to be drained, do this outdoors.
1. When machine is to be parked, stored, or left unattended, lower brush section and bucket.
2. Allow the engine to cool before storing in any enclosure.
3. Only cover the machine with a sheet after hot parts have sufficiently cooled down.

4. Never store the equipment with fuel in the tank inside a building where fumes may reach an open flame or spark.
5. If the engine is provided with a shut-off valve, shut off valve while storing or transporting.
6. Do not store fuel near flames.

Recycle and Waste Disposal Page 2-2

About RecyclePage 2-2

About Waste Disposal Page 2-2



Disposal

Disposal

Recycle and Waste Disposal

About Recycle

Recycling battery etc. is recommended for environmental conservation and economical use of resources.

It may be required by local laws.

About Waste Disposal

Make sure that waste generated when servicing or repairing the machine is disposed of in accordance with local regulations. (e.g. waste oil, antifreeze, rubber products, and wires etc.)

Specifications Page 3-2

- SpecificationsPage 3-2
- Sound Pressure Level Page 3-3
- Sound Power Level Page 3-3
- Vibration LevelPage 3-3

Names of Each Section Page 3-4

Regulation DecalsPage 3-4

- Positions of Regulation Decals Page 3-4
- Description of Regulation Decals Page 3-4

Safety Signs and Instruction Signs Page 3-5

- About Safety Signs and Instruction
SignsPage 3-5
- Positions of Safety Decals and
Instruction Decals Page 3-5
- Description of Safety Decals and
Instruction Decals Page 3-6

Product Overview

Specifications

Specifications

Model		FS900 (Type: Urethane tires)	FS900 (Type: Rubber tires)
Dimensions	Total length	258 cm	257 cm
	Total width	177 cm	173 cm
	Total height	Bucket Frame	149 cm
Bottom of discharge opening (when bucket raised to the highest level)		150 cm	149 cm
Weight	Machine (empty fuel tank)	762 kg	710 kg
Minimum turning radius		275 cm	
Engine	Model	Vanguard 356447	
	Type	Air-cooled 4-cycle gasoline engine	
	Total displacement	570 cm ³ (0.57 L)	
	Maximum output	13.2 kW (18.0 PS)/3,600 rpm	
Fuel tank capacity		Gasoline 20.0 dm ³ (20.0 L)	
Fuel consumption		310 g/kW · h (rated output)	
Engine oil capacity		1.6 dm ³ (1.6 L)	
Coolant volume		-	
Hydraulic tank capacity		17.0 dm ³ (17.0 L)	
Operating width		81 cm	
Operating height		-	
Bucket capacity		414 dm ³ (414 L)	
Drive	Traveling	HST (2WD)	
	Sweeping section	Hydraulic, Mechanical	
Speed (HST)	Forward	0 - 16.0 km/h	
	Reverse	0 - 5.0 km/h	
Speed (Mechanical)		-	
Efficiency		5,184 m ² /h (8.0 km/h x operating width x 0.8)	
Maximum inclination for operation		10 degrees	
Tire size	Front wheel	φ450 x 250 mm	18 x 9.50 - 8
	Rear wheel	φ500 x 300 mm	20 x 10.00 - 10
Tire pneumatic pressure	Front wheel	-	80 kPa (0.8 kgf/cm ²)
	Rear wheel	-	120 kPa (1.2 kgf/cm ²)
Battery		40B19L	
Engine plug		PLUG, CHAMPION XC92YC	

* The factory default maximum engine rpm is 3,000 rpm.

Sound Pressure Level

Sound pressure level

This machine was confirmed to have a continuous A-weighted sound pressure level of 82 dB by measuring identical machines in accordance with the procedure specified in ISO5395-1:2013.

Sound Power Level

Sound Power Level

This machine was confirmed to have a sound power level of 98 dB by measuring identical machines in accordance with the procedure specified in ISO5395-1:2013.

Vibration Level

Hand-Arm Vibration

This machine was confirmed not to exceed a vibration level of 2.5 m/s^2 to hands and arms by measuring identical machines in accordance with the procedure specified in ISO 5395-1:2013.

Uncertainty $K = 0.7 \text{ m/s}^2$

Whole Body Vibration

This machine was confirmed not to exceed a vibration level of 0.5 m/s^2 to the whole body by measuring identical machines in accordance with the procedure specified in ISO 5395-1:2013.

Uncertainty $K = 0.2 \text{ m/s}^2$

Product Overview

Names of Each Section

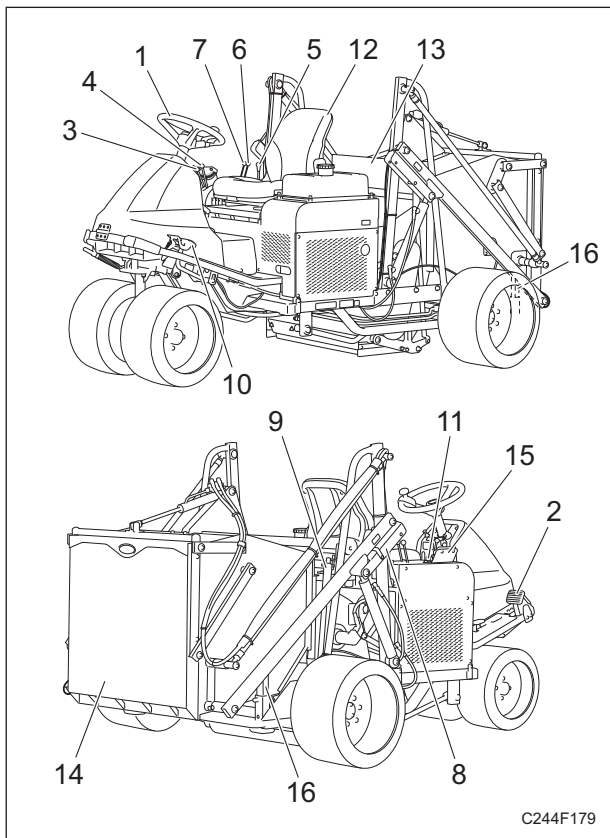

Names of Each Section_001

1	Handle
2	Traveling pedal
3	Brush rotation lever
4	Brush up/down lever
5	Roller presser lever
6	Bucket up/down lever
7	Bucket open/close lever
8	Cylinder lock
9	Brush adjusting lever
10	Brake pedal
11	Throttle lever
12	Seat
13	Brush frame
14	Bucket
15	Angle Meter
16	Outrigger

Regulation Decals

Positions of Regulation Decals

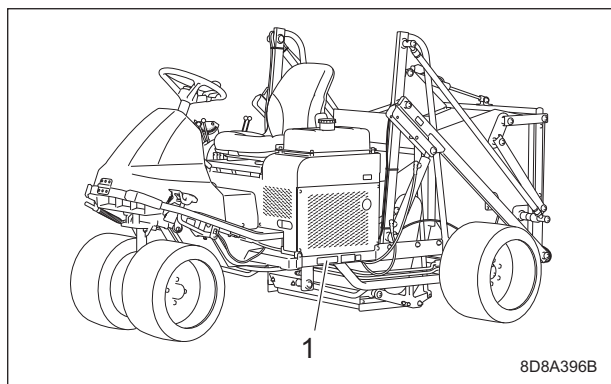

Positions of Regulation Decals_001

A	Serial number plate
---	---------------------

Description of Regulation Decals

Serial Number Plate

The serial number plate indicates the model and serial number of the machine.

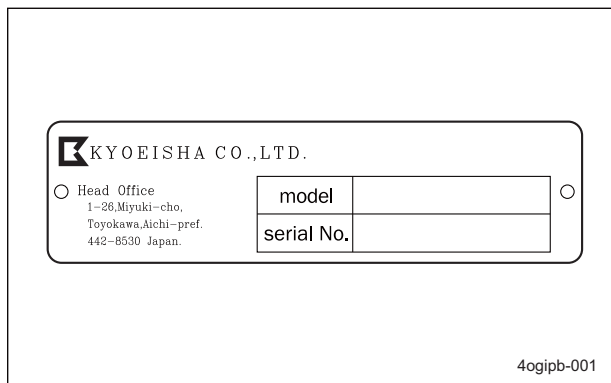

Serial Number Plate_001

Safety Signs and Instruction Signs

About Safety Signs and Instruction Signs

Important

Safety decals and instruction decals are attached to this product. Make sure that they are preserved in their entirety. If they are damaged, become dirty, or peel off, replace them with new ones.

Part numbers for decals that need to be replaced are listed in the parts catalog. Order them from a Baroness dealer or Kyoisha.

Positions of Safety Decals and Instruction Decals

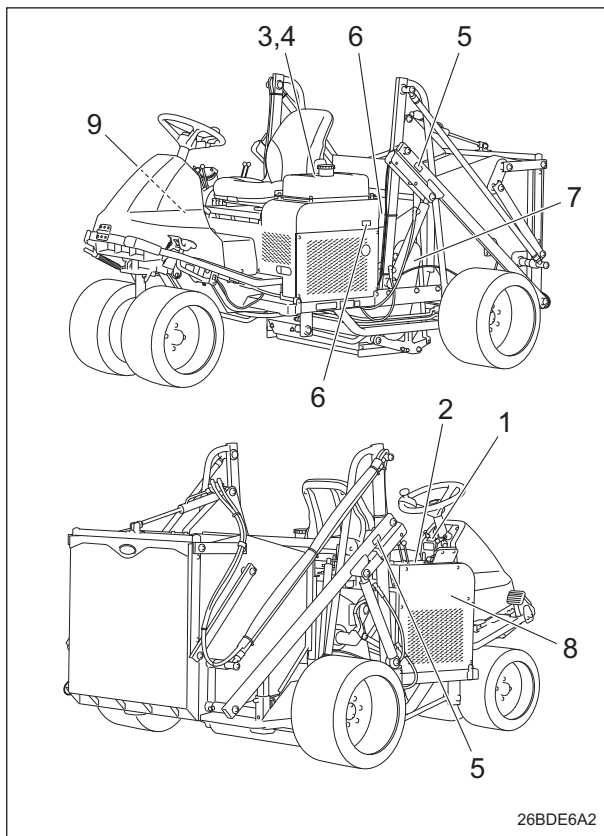

Positions of Safety Decals and Instruction Decals_001

1	Operation decal
2	Operation decal
3	Lead-free gasoline decal
4	Fire prohibited decal
5	Locking attention decal
6	Caution for high temperatures decal
7	Caution to getting entangled decal
8	Hydraulic oil icon
9	Prohibited drive at public road decal

Product Overview

Description of Safety Decals and Instruction Decals

Operation Decal

FS900--0512Z0
Decal, operation

1.



Warning

Read the Owner's Operating Manual.

2.



Warning

Apply the parking brake, stop the engine, remove the ignition key, and then leave the machine.

3.

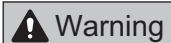

Warning

Rollover - Do not work on slopes of 10 degrees or more.

4.

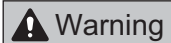

Warning

Never perform high dumping while traveling since the machine will become unbalanced.

5.



Warning

Never operate while obstacles, such as people or animals, are in the operating area.

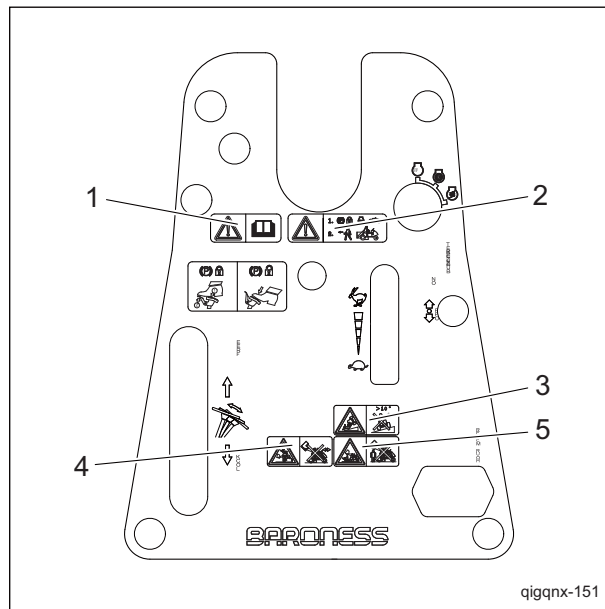

Operation Decal_001

Product Overview

Operation Decal

FS900--0514Z0
Decal, operation

1.

Caution

Caution for flying object - When the brushes are rotating, keep away from the machine.

2.

Warning

While performing inspections or maintenance, make sure that the locking mechanism is lowered onto the cylinder.

3.

Warning

Read the Owner's Operating Manual.

4.

Caution

Hands and feet getting caught - Stop the brush rotation and engine. Otherwise you may be injured.

5.

Warning

Caution for exhaust gas

6.

Caution

When the seat is raised, there is a possibility of being pinched if the seat is not locked.

7.

Warning

Do not perform high dumping on a slope. Otherwise the machine may roll over.

8.

Warning

Do not perform high dumping near obstacles, such as trees or overhead power lines.

9.

Danger

Do not perform high dumping in dangerous areas, such as near cliffs.

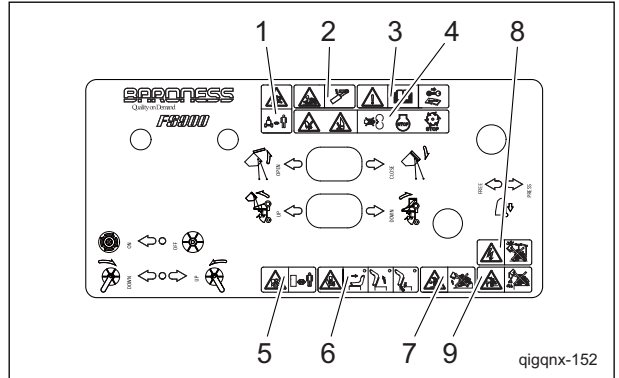

Operation Decal_001

Lead-Free Gasoline Decal

K4209001310
Decal, lead-free gasoline
Use lead-free gasoline.



Lead-Free Gasoline Decal_001

Product Overview

Fire Prohibited Decal

K4205001940
Decal, fire prohibited

Warning
Keep away from fire.



Fire Prohibited Decal_001

Caution for High Temperatures Decal

K4205001920
Decal, caution for high temperatures

Caution
High temperature - Do not touch. Otherwise, you will get burned.



Caution for High Temperatures Decal_001

Locking Attention Decal

K4205001980
Decal, caution locking

Warning
Before inspection and maintenance, be sure to apply the locking device to the cylinder.

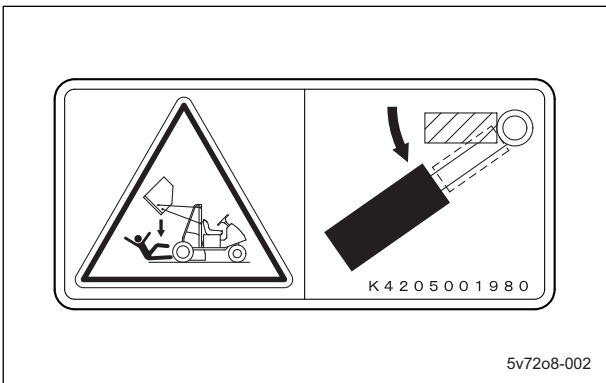

Locking Attention Decal_001

Caution to Getting Entangled Decal

K4205001910
Decal, caution to getting entangled

Warning
Watch for rotating parts - Keep your hands away from the belts while the engine is running.

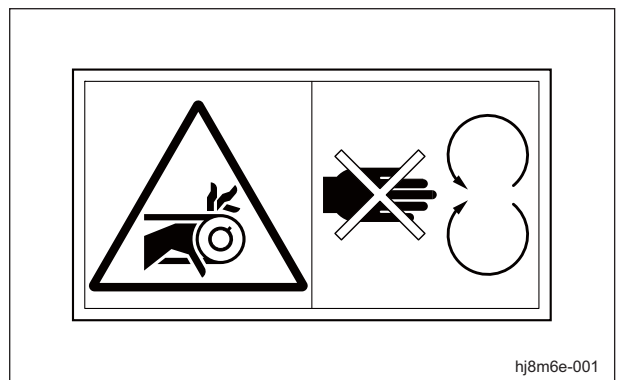

Caution to Getting Entangled Decal_001

Hydraulic Oil Icon

K4209000980

Hydraulic oil icon

Read the Owner's Operating Manual.

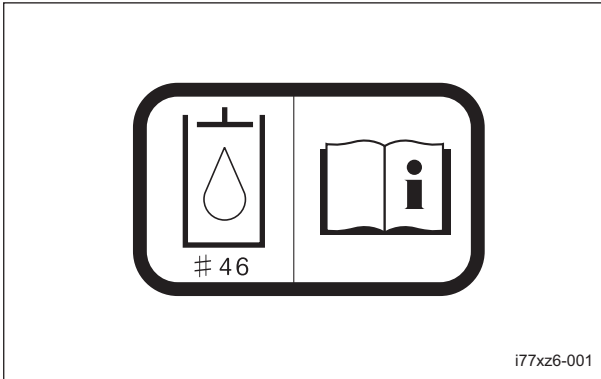

Hydraulic Oil Icon_001

Prohibited Drive at Public Road Decal

K4205001660

Decal, not to drive at public road



Prohibited Drive at Public Road Decal_001

Product Overview

Handling Instructions

Inspections	Page 4-2	Traveling Pedal	Page 4-22
Daily Check List	Page 4-2	Brake Pedal	Page 4-22
Bucket	Page 4-3	Throttle Lever	Page 4-22
Outrigger	Page 4-3	Choke Lever	Page 4-23
Cover	Page 4-3	Brush Up/Down Lever	Page 4-23
Hydraulic Oil	Page 4-3	Brush Rotation Lever	Page 4-23
Hydraulic Hoses	Page 4-5	Bucket Up/Down Lever	Page 4-24
Air Cleaner	Page 4-5	Bucket Open/Close Lever	Page 4-25
Battery	Page 4-6	Roller Press Lever	Page 4-25
Electrical Wiring	Page 4-7	Urethane Tires	Page 4-26
Tire	Page 4-7	Outrigger	Page 4-26
Brake	Page 4-7	Cylinder Lock	Page 4-27
Belt	Page 4-7	Underseat Cover	Page 4-28
Wire	Page 4-8	Warning Buzzer Switch	Page 4-28
Safety Device	Page 4-8	Instruments	Page 4-29
Around The Engine	Page 4-8	Instruments on the Operation Panel	Page 4-29
Engine Oil	Page 4-8	Warning Lamp	Page 4-29
Fuel	Page 4-9	Hour Meter	Page 4-29
Fuel Filter	Page 4-10	Angle Meter	Page 4-29
Fuel Strainer	Page 4-10	Move	Page 4-29
Oil Leakage	Page 4-10	Traveling Operation	Page 4-29
Tightening Torques	Page 4-11	Towing the Machine	Page 4-30
Standard Tightening Torques	Page 4-11	Operations	Page 4-31
Principal Tightening Torques	Page 4-14	Collecting Operation	Page 4-31
Adjustment before Work	Page 4-15	Dumping Operation	Page 4-32
Adjustment of Steering Wheel	Page 4-15	Transporting	Page 4-33
Adjustment of Seat	Page 4-15	Transporting Procedure	Page 4-33
Adjustment of Speed Adjusting Plate ..	Page 4-15	Storage	Page 4-33
Adjustment of Brush Operation		Before Long-Term Storage	Page 4-33
Height	Page 4-16		
Procedure to Start/Stop Engine	Page 4-17		
Start/Stop of Engine	Page 4-17		
Safety Mechanisms	Page 4-18		
Operation Method	Page 4-18		
Cautions for when You Leave The			
Machine	Page 4-18		
Positions of Operation Decals	Page 4-18		
Description of Operation Decals	Page 4-19		

Handling Instructions

Inspections

Inspect the machine according to the daily check list so that you will be able to take advantage of its optimum performance for a long period of time.

Daily Check List

- . . . Inspect, adjust, supply, clean
- . . . Replace (first time)
- △ . . . Replace

Maintenance Item		Before Work	After Work	Remarks
*1	Check engine oil level and contamination	○		
	Check fuel level	○		
	Check contamination, looseness and damage of air cleaner	○		
	Check hydraulic oil level	○		
	Check tire pressures and condition	○		
	Check cover condition	○		
	Check bucket damage	○		
	Check bucket lid damage	○		
	Check outrigger condition	○		
	Check actuation of traveling pedal	○		
	Check brake function	○		
	Check play of brake pedal	○		
	Check actuation of handle	○		
	Adjust brush operation height	○		
	Check leakage of oil and fuel	○		
	Check damaged parts	○		
	Check tightening bolts and nuts	○		
	Check turning on the lights	○		
	Check actuation of interlocking system	○		
	Clean machine exterior		○	
	Clean engine area		○	
	Clean brush area		○	
	Clean inside of bucket		○	

*1: Refer to the Engine's Owner's Manual.

Handling Instructions

Bucket

Inspection of Bucket

The bucket may become damaged due to frequent use, objects picked up while sweeping, or transportation. Inspect the bucket, and if necessary, replace it.

1. Make sure that there are no cracks, etc.
2. Make sure that the rubber frame is not peeling off.

Inspection of Bucket Lid

The bucket lid may become damaged due to frequent use, objects picked up while sweeping, or transportation. Inspect the bucket lid, and if necessary, replace it.

1. Make sure that the lid closes securely.
2. Make sure that there are no cracks, etc.

Outrigger

Inspection of Outrigger

The outriggers may happen to be damaged during traveling, etc. Inspect and, if necessary, repair or replace.

1. Make sure that there is no bend or deformation.
2. Make sure that there is not damage or deterioration.
3. Make sure that the pin is not missing.

Cover

Inspection of Covers

⚠ Caution

If you have removed a protective cover during inspection, be sure to securely install it in its original position.

If a protective cover remains removed, foreign objects may fly off, possibly resulting in injuries.

1. Make sure that there is no wear or deterioration of protective covers.
2. Make sure that there is no damage to protective covers.
3. Make sure that there is no interference with moving parts due to deformation of protective covers.

4. Make sure that protective covers are installed in their appropriate positions.

Hydraulic Oil

Inspection of Hydraulic Oil

1. On a level surface, lower the brush frame and the bucket and maintain that position.
2. Make sure that the oil level is at the middle of the oil gauge.

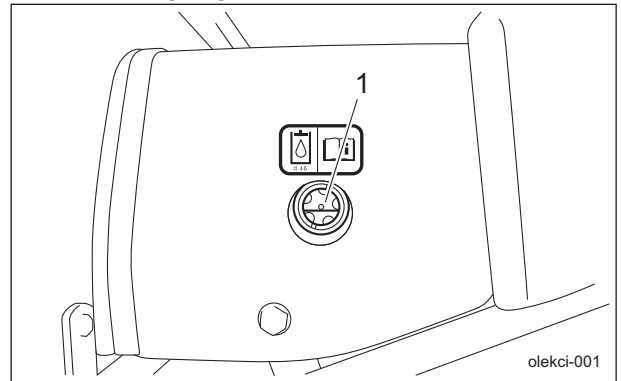

Inspection of Hydraulic Oil_001

1	Oil gauge
---	-----------

3. Check underneath the machine for oil leakage.

Handling Instructions

Hydraulic Oil Supply

Important

Do not mix different types of oil.

Important

Use Shell Tellus S2M46 (or equivalent) as hydraulic oil. In case of an equivalent, consult Characteristics of Hydraulic Oil and use hydraulic oil whose characteristics are superior to those of the specific hydraulic oil. Especially regarding kinematic viscosity and viscosity index, use of hydraulic oil whose figures are less than those of the specified hydraulic oil will cause a malfunction in the hydraulic circuit.

Note:

Characteristics of Hydraulic Oil

Specified Hydraulic Oil	Shell Tellus S2M46	
ISO Viscosity Grade	ISO VG46	
Density	15 °C (59 °F)	0.873 g/cm ³ (0.0315 lb/in ³)
API Gravity	30.6	
Flash Point (Open Cup)	230 °C (446 °F)	
Pour Point	-30 °C (-22 °F)	
Kinematic	40 °C (104 °F)	46 mm ² /s (46 cSt)
Viscosity	100 °C (212 °F)	7 mm ² /s (7 cSt)
Viscosity Index	109	

1. Remove the knobs, and then open the front cover.

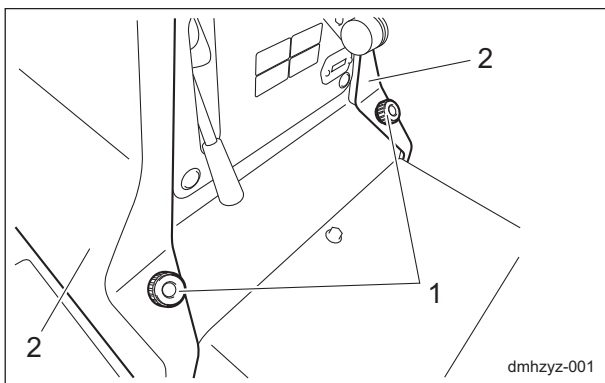

Hydraulic Oil Supply_001

1	Knobs
2	Front cover

2. Remove the bolts, and then open the cover.

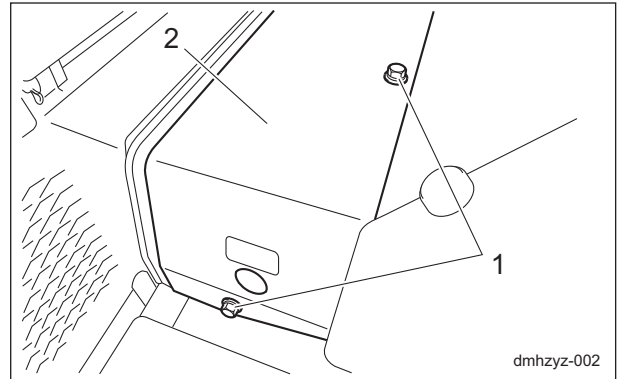

Hydraulic Oil Supply_002

1	Bolt
2	Cover

3. If the hydraulic oil level is low, follow the steps below to supply oil.

[1] Open the tank cap, and then supply hydraulic oil through the oil filling port until the oil level reaches the middle of the oil gauge on the hydraulic tank.

[2] Tighten the tank cap securely.

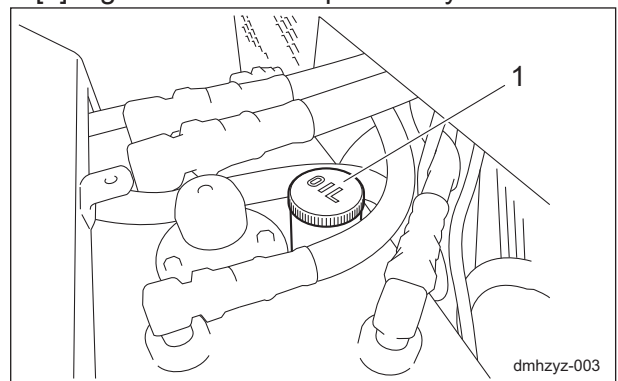

Hydraulic Oil Supply_003

1	Tank cap
---	----------

4. Start the engine, raise and lower the brush frame and the bucket, and then drive the machine forward and in reverse repeatedly several times.

5. On a level surface, lower the brush frame and the bucket and maintain that position, and then check to see if the oil level is at the middle of the oil gauge. If necessary, supply oil.

6. Check underneath the machine for oil leakage.

7. Install the cover.

8. Close the front cover.

Handling Instructions

Hydraulic Hoses

Inspection of Hydraulic Hoses

Warning

When checking the hydraulic circuit for pinhole leaks or oil leakage from nozzles, do not use your hands. Use items such as paper or corrugated cardboard to find leakage points.

Be extremely careful with high-pressure oil as it may pierce your skin, resulting in personal accidents.

If fluid is injected into the skin it must be surgically removed within a few hours by a doctor familiar with this form of injury or gangrene may result.

Check the pipes and hoses to make sure that there is no oil leakage, circuit damage, looseness, wear, connector looseness, weather deterioration and chemical deterioration.

Make any necessary repairs before operating the machine.

Air Cleaner

Inspection of Air Cleaner

1. Open the underseat cover.
2. Make sure that there is no damage to the air cleaner.
3. Make sure that the air cleaner element is not contaminated.

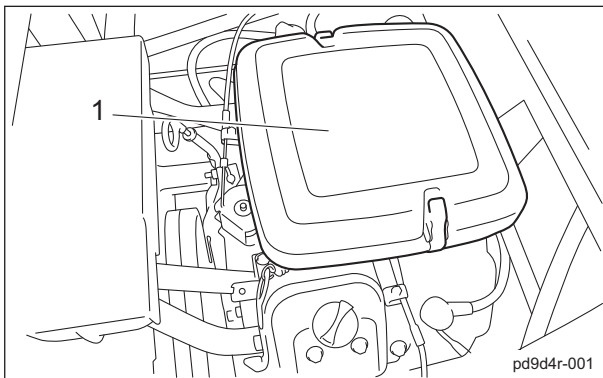

Inspection of Air Cleaner_001

1	Air cleaner
---	-------------

4. Close the underseat cover.

Cleaning of Air Cleaner

A contaminated air cleaner element may cause malfunction of the engine. To maximize the life of the engine, clean the air cleaner properly.

1. Open the underseat cover.

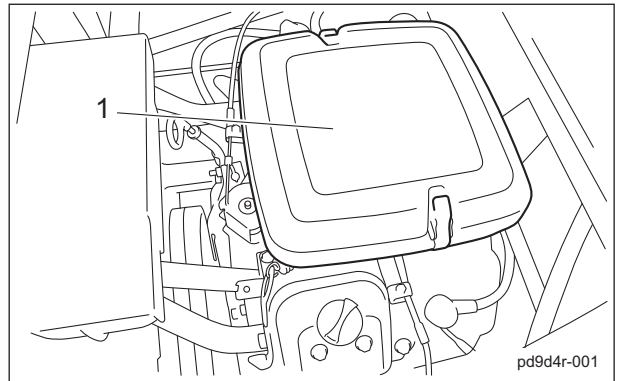

Cleaning of Air Cleaner_001

1	Air cleaner
---	-------------

2. Remove the clip, and then remove the cover.
3. Remove the knob and plate, and then remove the air cleaner element.
4. Remove the pre-cleaner from the air cleaner element.

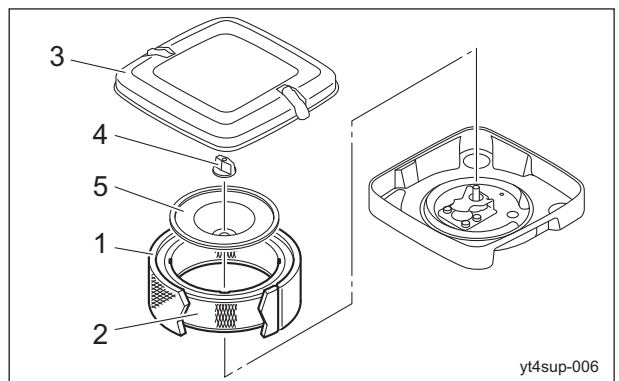

Cleaning of Air Cleaner_002

1	Pre-cleaner
2	Air cleaner element
3	Cover
4	Knob
5	Plate

Handling Instructions

Important

When cleaning the air cleaner element, do not use a petroleum solvent.
 When cleaning and drying the air cleaner element, do not use compressed air.
 Do not infiltrate oil with the pre-cleaner.

5. Rinse the pre-cleaner with liquid detergent and dry it out by pressing with clean cloth.
6. While paying close attention not to damage the air cleaner element, tap a solid portion of the air cleaner element to remove dust and dirt.
 If the air cleaner element is damaged or dirty, replace it.
7. Install the air cleaner element and pre-cleaner.
8. Install the plate and knob.
9. Install the cover, and then fix it securely using the clip.
10. Close the underseat cover.

Battery

Inspection of Battery

⚠ Danger

Keep fire away while inspecting or charging the battery.
 The battery may explode.

⚠ Warning

Do not allow the battery fluid level to become lower than the LOWER LEVEL (minimum fluid level line).
 The battery may explode if it is used or charged while the battery fluid level is at the LOWER LEVEL (minimum fluid level line).

⚠ Caution

Implement after the engine and muffler etc. have well cooled down.
 Otherwise you may get burned.

1. Clean the areas around the battery fluid level lines using a cloth dampened with water.

2. Make sure that the battery fluid level is between the UPPER LEVEL (maximum fluid level line) and the LOWER LEVEL (minimum fluid level line).

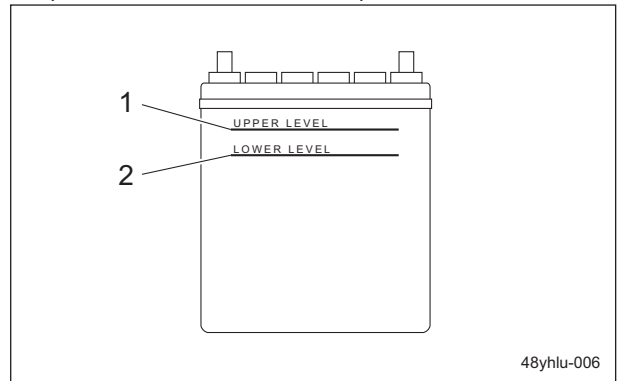

Inspection of Battery_001

1	UPPER LEVEL
2	LOWER LEVEL

Supply of Battery Fluid

⚠ Danger

Be careful not to let your skin, eyes or clothes, etc., come into contact with the battery fluid or accidentally swallow the fluid.
 Should your skin or clothes come into contact with the battery fluid, immediately wash them away with water.

⚠ Danger

When you supply battery fluid, wear protective garments and safety glasses, etc.

⚠ Caution

Implement after the engine and muffler etc. have well cooled down.
 Otherwise you may get burned.

1. If the battery fluid level is lower than halfway between the UPPER LEVEL (maximum) line and LOWER LEVEL (minimum) line, add purified water up to the UPPER LEVEL (maximum) line.

Handling Instructions

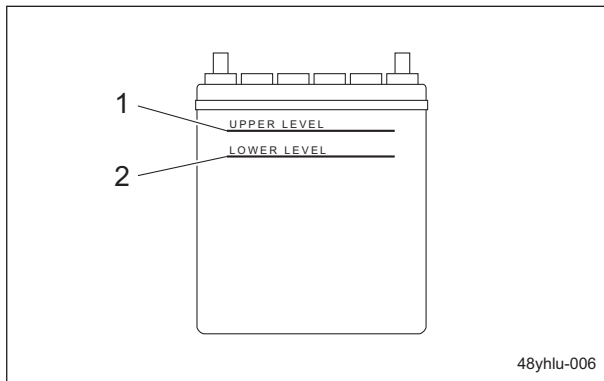

Supply of Battery Fluid_001

1	UPPER LEVEL
2	LOWER LEVEL

Electrical Wiring

Inspection of Electrical Wiring

Important

Electrical short circuit will cause fire, electrical leakage and malfunction of electrical equipments.

Inspect electrical wiring for poor terminal connections, damaged wiring or terminals, loose connections, weather-related deterioration and chemical-related deterioration.

If necessary, repair before operating the machine.

Tire

Inspection of Tires

1. Check the pneumatic pressure of the tires.
2. Make sure that there are no cracks, damage or abnormal wear.

Type: Rubber tires

Tire size	Pneumatic pressure
Front wheel (18 x 9.50 - 8)	80 kPa (0.8 kgf/cm ²)
Rear wheel (20 x 10.00 - 10)	120 kPa (1.2 kgf/cm ²)

Brake

Inspection of Brake Pedal

1. When depressing the brake pedal fully, make sure that there is appropriate clearance between the floorboard and the pedal or pedal reserve distance.
2. When depressing the brake pedal fully, make sure that the pedal reaction is not spongy and that there is no noise.
3. When depressing the brake pedal during traveling, make sure that the machine stops smoothly and the braking is sufficiently effective.

Inspection of Parking Brake

1. Depress the locking pedal while firmly depressing the brake pedal to lock it and check that the brake is applied effectively.
2. Firmly depress the brake pedal and release the locking pedal to release the brake pedal, and then check that the brake is not applied.

Belt

Inspection of Belts

Warning

Be sure to stop the engine before inspecting the belts.

Warning

If you have removed any covers, etc., during inspection, make sure that you securely re-attach them in their original positions. If covers, etc., remain removed, the operator may come into contact with rotating parts or belts, and foreign objects may fly off, possibly resulting in injuries.

1. Press the middle of the belt with your finger to check the belt tension.
2. Make sure that there are no cracks, damage or abnormal wear.

Handling Instructions

Wire

Inspection of Wire

1. Make sure that the wire is not cracked or damaged.
2. If the wire is cracked or damaged, replace it with a new one immediately.

Safety Device

Inspection of Safety Device

Make sure that the safety device operates correctly.
 "Safety Mechanisms" (Page 4-18)

Around The Engine

Inspection of Engine-Associated Parts

1. Check the fuel system parts for loosened or cracked joints and leakage. Replace the parts if necessary.
2. Blow compressed air to clean any grass or flammable materials that may be attached on or around the muffler.

Engine Oil

Inspection of Engine Oil

Important

Securely tighten the oil level gauge and oil filler cap.

1. Open the underseat cover.
2. Stop the engine, wait for 10 to 20 minutes for the engine to cool down, and then check the oil level.
3. Position the machine so that the engine will be level, then insert the oil gauge all the way to check the oil level.

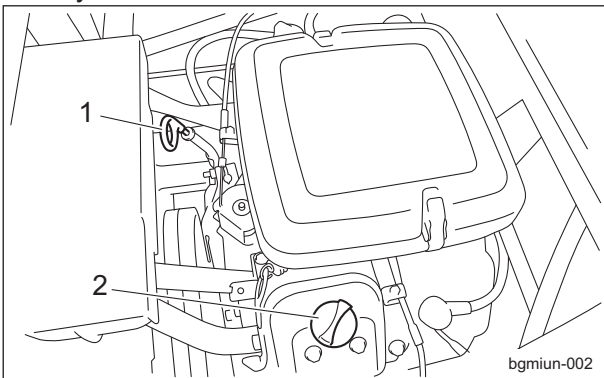

Inspection of Engine Oil_001

1	Oil level gauge
2	Oil filler cap

4. The appropriate oil level should be between the upper and lower limit lines on the gauge.

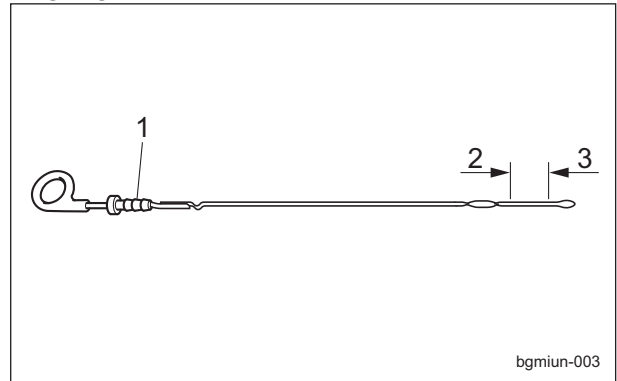

Inspection of Engine Oil_002

1	Oil level gauge
2	Upper limit
3	Lower limit

5. Close the underseat cover.

Handling Instructions

Supply of Engine Oil

Important

Do not fill too much engine oil. Otherwise, the engine may be damaged.

Important

Do not mix different types of engine oil.

Important

Be sure to use engine oil that is classified as API Service Grade SF or higher, with an SAE Viscosity that is appropriate for the operating environment (ambient temperature).

Important

Securely tighten the oil level gauge and oil filler cap.

1. Open the underseat cover.
2. Through the oil filling port, supply the engine oil.
Remove the oil filler cap, and then supply new engine oil until the oil reaches a level in between the upper and lower limit lines on the oil level gauge.
3. Re-place the oil filler cap.

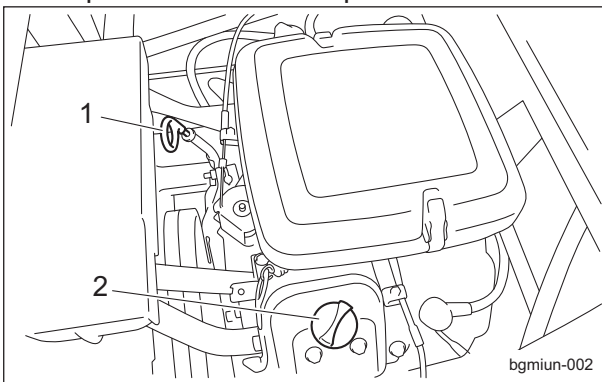

Supply of Engine Oil_001

1	Oil level gauge
2	Oil filler cap

4. It will take a while for the supplied engine oil to descend into the oil pan.
Check the oil level again 10 to 20 minutes after supplying the oil.
5. Close the underseat cover.

Fuel

Inspection of Fuel Quantity

With the machine on a level surface, observe the fuel gauge on the fuel tank to check the fuel level.

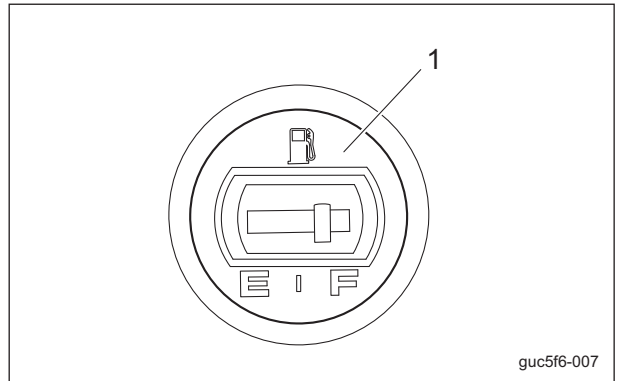

Inspection of Fuel Quantity_001

1	Fuel gauge
---	------------

Fuel Supply

Warning

Keep fire away while refueling.
Do not smoke while refueling.

Warning

Do not supply fuel above F (FULL) level of the fuel gauge.
If you supply too much fuel, it might overflow from the tank cap when you travel or work on a slope.

If the fuel gauge located on the fuel tank indicates a level close to E (EMPTY), supply lead-free gasoline for automobiles at your earliest convenience.

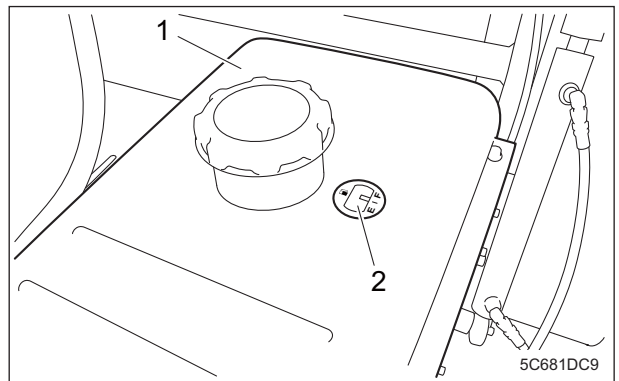

Fuel Supply_001

Handling Instructions

1	Fuel tank
2	Fuel gauge

The fuel tank capacity up to the red ring of strainer is approximately 20.0 dm³ (20.0 L).

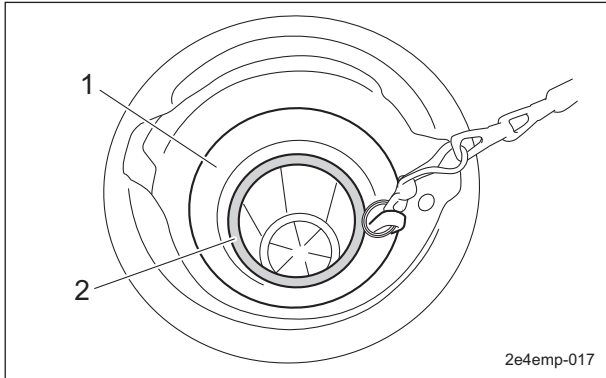

Fuel Supply_002

1	Strainer
2	Red ring

Fuel Filter

Inspection of Fuel Filter

The fuel filter works to remove foreign objects mixed into the fuel.

When the fuel flow becomes insufficient, replace the fuel filter if necessary.

1. Make sure that there is no fuel leakage.
2. Make sure that the fuel filter is not damaged or dirty.

Fuel Strainer

Inspection of Fuel Strainer

The fuel strainer is installed near the fuel tank and cleans the fuel that enters the carburetor. If the fuel flow is insufficient, clean or replace the fuel strainer as necessary.

1. Make sure that there is no fuel leakage.
2. Make sure that the fuel strainer is not damaged or dirty.

Cleaning of Fuel Strainer

If the fuel strainer becomes clogged with dust and dirt, the fuel flow will become insufficient. Periodically clean it.

Important

Shut off the fuel valve, and then clean the fuel strainer in a clean location, free of dust and dirt.

1. Open the underseat cover.
2. Remove the filter pot, wash the filter and inside of the filter pot using a solvent, such as a hardly flammable kerosene, and then blow compressed air to dry them.

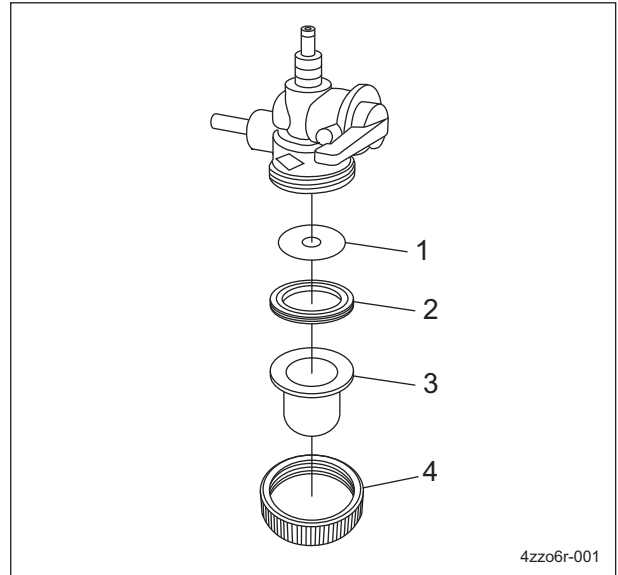

Cleaning of Fuel Strainer_001

1	Filter
2	Packing
3	Filter pot
4	Ring

3. Make sure that there is no fuel leakage after it is installed.
4. Close the underseat cover.

Oil Leakage

Inspection of Oil Leakage

Caution

When performing maintenance on the hydraulic system, lower the brush frame and the bucket.

After approximately 50 hours of operation, some tightened portions may be loosened and oil and grease may leak. Be sure to retighten the parts. Check the bottom of the machine for oil and grease leakage.

Tightening Torques

Important

Refer to the Tightening Torque table.
Note that the Baroness product warranty may not apply to defects caused by incorrect or overtorque tightening, etc.

Standard Tightening Torques

Bolts and Nuts

Important

A number of bolts are used in each part of this machine.
Be sure to re-tighten the bolts and nuts, because they may be loosened at the earlier stage of the use.

As to the bolts and nuts without any special instruction, tighten them in appropriate tightening torque with proper tool.

Too much tightening may cause the looseness or damage of the screw.

The strength of tightening is determined by types of screws, strength, the friction of thread face or base face and others.

The table below is for the galvanized or parkerized bolts.

In case that the strength of internal thread is weak, it is not applied.

Do not use rusty or sand attached "screw."

Otherwise, it may cause insufficient tightening even if you apply the specified tightening torque.

The friction of the screw face becomes higher and the tightening torque is canceled out by the friction, therefore sufficient tightening cannot be applied.

If "screw" is wet by water or oil, do not tighten it with normal tightening torque.

If the screw is wet, the torque coefficient will get smaller and it may result in too much tightening.

Too much tightening may cause looseness by the screw stretched or result in damage.



Do not use a bolt experienced too much burden.

Using the impact wrench requires the skill.

Do exercise as much as possible for steady tightening.

Handling Instructions

Nominal diameter	General bolt		
	Strength classification 4.8		
	 tib3yb-001		
	N-m	kgf-cm	lb-in
M5	3 - 5	30.59 - 50.99	26.55 - 44.26
M6	7 - 9	71.38 - 91.77	61.96 - 79.66
M8	14 - 19	142.76 - 193.74	123.91 - 168.17
M10	29 - 38	295.71 - 387.49	256.68 - 336.34
M12	52 - 67	530.24 - 683.20	460.25 - 593.02
M14	70 - 94	713.79 - 958.52	619.57 - 831.99
M16	88 - 112	897.34 - 1142.06	778.89 - 991.31
M18	116 - 144	1,182.85 - 1,468.37	1,026.72 - 1,274.54
M20	147 - 183	1,498.96 - 1,866.05	1,301.10 - 1,619.73
M22	295	3,008.12	2,611.05
M24	370	3,772.89	3,274.87
M27	550	5,608.35	4,868.05
M30	740	7,545.78	6,549.74

Nominal diameter	Heat-treated bolt					
	Strength classification 8.8			Strength classification 10.9		
	 tib3yb-002			 tib3yb-003		
	N-m	kgf-cm	lb-in	N-m	kgf-cm	lb-in
M5	5 - 7	50.99 - 71.38	44.26 - 61.96	7 - 10	71.38 - 101.97	61.96 - 88.51
M6	8 - 11	81.58 - 112.17	70.81 - 97.36	14 - 18	142.76 - 183.55	123.91 - 159.32
M8	23 - 29	234.53 - 295.71	203.57 - 256.68	28 - 38	285.52 - 387.49	247.83 - 336.34
M10	45 - 57	458.87 - 581.23	398.30 - 504.51	58 - 76	591.43 - 774.97	513.36 - 672.68
M12	67 - 85	683.20 - 866.75	593.02 - 752.34	104 - 134	1,060.49 - 1,366.40	920.50 - 1186.03
M14	106 - 134	1,080.88 - 1,366.40	938.21 - 1,186.03	140 - 188	1,427.58 - 1,917.04	1,239.14 - 1,663.99
M16	152 - 188	1,549.94 - 1,917.04	1,345.35 - 1,663.99	210 - 260	2,141.37 - 2,651.22	1,858.71 - 2,301.26
M18	200 - 240	2,039.40 - 2,447.28	1,770.20 - 2,124.24	280 - 340	2,855.16 - 3,466.98	2,478.28 - 3,009.34
M20	245 - 295	2,498.27 - 3,008.12	2,168.50 - 2,611.05	370 - 450	3,772.89 - 4,588.65	3,274.87 - 3,982.95
M22	-	-	-	530	5,404.41	4,691.03
M24	-	-	-	670	6,831.99	5,930.17
M27	-	-	-	1,000	10,197.00	8,851.00
M30	-	-	-	1,340	14,628.78	11,860.34

Note:
The same values are applied to "fine screw thread."

Handling Instructions

Hydraulic Hose

The tightening torques for union joints and union adaptors with parallel pipe threads (G, PF) are shown in the table below.

A union joint or adaptor will not become loose or leak as long as it is tightened by the specified torque.

If fluid leaks from the sealed portion, do not attempt to tighten the union joint or adaptor forcibly. Examine whether any foreign matter or scratches are present on the seat surface.

Tightening a union joint or adaptor forcibly could damage the connection of the joints.

When tightening a union joint or adaptor, use a torque wrench where possible and firmly tighten it by an appropriate torque.

Nominal diameter of the hose size	Nominal diameter of the parallel pipe threads (G, PF)	Tightening torque		
		N-m	kgf-cm	lb-in
6	1/4	24.50	250	221.28
9	3/8	49.03	500	564.91
12	1/2	58.84	600	677.89
15	3/4	117.68	1200	1,355.78
19	3/4	117.68	1200	1,355.78
25	1	137.30	1400	1,581.74
32	1-1/4	166.72	1700	1,920.69
38	1-1/2	205.94	2100	2,372.61
50	2	245.17	2500	2,824.54

Fittings with Parallel Threads (O-Ring Seal Type)

The tightening torques for fittings with parallel threads (O-ring seal method) are shown in the table below.

Tightening the fitting forcibly with a spanner or other such tool to secure it to a set position could damage the fitting, its washers, and other parts. Be sure to tighten the fitting to the torque appropriate to its size.

Nominal diameter of thread	Tightening torque		
	N-m	kgf-cm	lb-in.
1/4	34.32 - 49.03	350 - 500	309.79 - 442.55
3/8	68.65 - 78.45	700 - 800	619.57 - 708.08
1/2	98.07 - 117.68	1000 - 1200	885.10 - 1,062.12
3/4	147.10 - 176.52	1500 - 1800	1,327.65 - 1,593.18
1	245.17 - 274.59	2500 - 2800	2,212.75 - 2,478.28
1-1/4	294.20	3000	2,655.30
1-1/2	294.20	3000	2,655.30
2	392.27	4000	3,540.40

Handling Instructions

Principal Tightening Torques

Tightening Torque by Model

FS900

Tighten the following bolts and nuts at the torque specified in the table.

For thread locking adhesive, apply a middle strength thread locker (ThreeBond 1322 or equivalent anaerobic sealant).

Location		Code	Part name	Tightening torque			Thread locking adhesive
				N-m	kgf-cm	lb-in	
Front wheel	Front wheel housing	K0011120252	Bolt, heat-treated M12-25P1.5	67 - 85	683.20 - 866.75	593.02 - 752.34	—
	Wheel	K0010100302	Bolt, heat-treated M10-30	58 - 76	591.43 - 774.97	513.36 - 672.68	—
Rear wheel	Wheel	K0011120302	Bolt, heat-treated M12-30P1.5	67 - 85	683.20 - 866.75	593.02 - 752.34	—
	Wheel mounting base	K0160000492	24 special nut P1.5	180 - 200	1,835.46 - 2,039.40	1,593.18 - 1,770.20	○
Front wheel arm		K0010100252	Bolt, heat-treated M10-25	45 - 76	458.87 - 774.97	398.30 - 672.68	—
Bucket mounting frame		K0010120602	Bolt, heat-treated M12-60	67 - 85	683.20 - 866.75	593.02 - 752.34	—
Orbit motor		YT40243M2	Connector, port RC3/8	45 - 50	458.87 - 509.86	398.30 - 442.55	—

Adjustment before Work

Adjustment of Steering Wheel

Warning

Since it is dangerous, do not adjust while traveling.

Use the tilt lever to adjust the steering wheel up or down.
 Adjust the position according to the operator's body size.
 Shift the tilt lever to the "FREE" position, move the steering wheel to the position that suits your work requirements, and then shift the tilt lever to the "LOCK" position to secure the steering wheel in place.
 The tilt lever is located at the center (in front of the driver's seat).

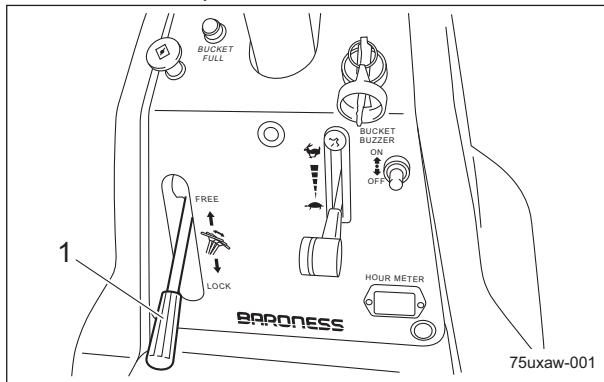

Adjustment of Steering Wheel_001

1	Tilt lever
---	------------

Adjustment of Seat

Warning

Since it is dangerous, do not adjust while traveling.

Use the adjustment lever to adjust the seat back and forth.
 Adjust the position according to the operator's body size.
 The adjustment lever is located on the left front part of the seat.

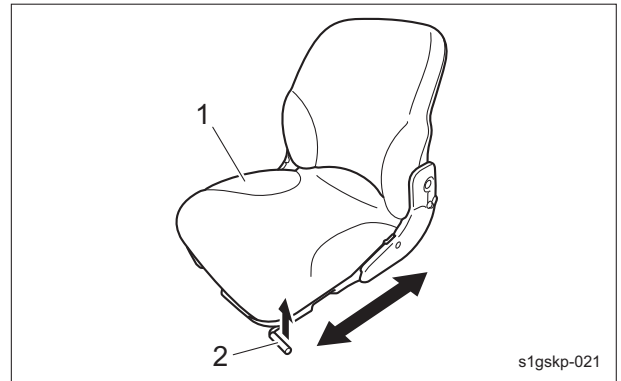

Adjustment of Seat_001

1	Seat
2	Adjustment lever

Adjustment of Speed Adjusting Plate

Warning

Since it is dangerous, do not adjust while traveling.

The bolts can be used to adjust the height of the speed adjusting plate.
 The speed adjusting plate is used to maintain a fixed operation speed.

1. Loosen the bolts.
2. Determine the operation speed, adjust the height of the speed adjusting plate, and then tighten the bolts.

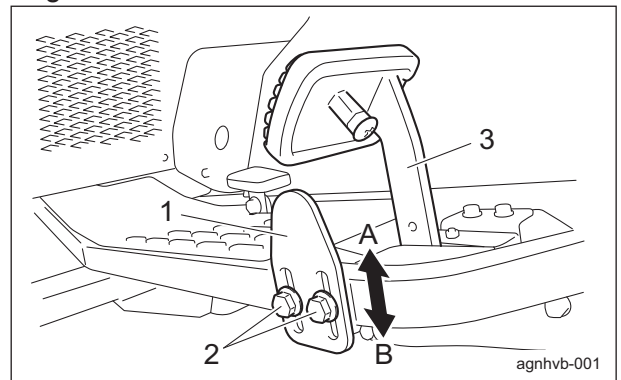

Adjustment of Speed Adjusting Plate_001

1	Speed adjusting plate
2	Bolt
3	Traveling pedal
A	Slower
B	Faster

Handling Instructions

Adjustment of Brush Operation Height

Warning

Be sure to stop the engine before adjusting the height of the brushes.

Important

If the brush operation height is inadequate, cores will not be properly collected.

Important

If the left and right sides of the brushes are at different heights, the cores will not be uniformly collected, and the brushes will wear unevenly.

Important

Adjust the height of the brushes according to the core size and quantity.

1. Move the machine to level ground, and then apply the parking brake.
2. Stop the engine.
3. Shift the brush up/down lever to the "DOWN" position to lower the brush frame.

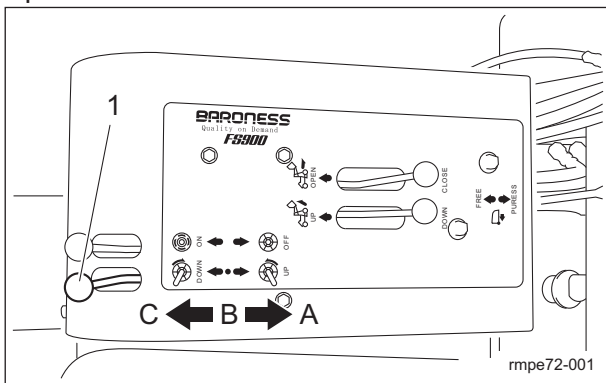

Adjustment of Brush Operation Height_001

1	Brush up/down lever
A	Up
B	Neutral
C	Down

4. Manually rotate the brushes until a brush is at its lowest point.

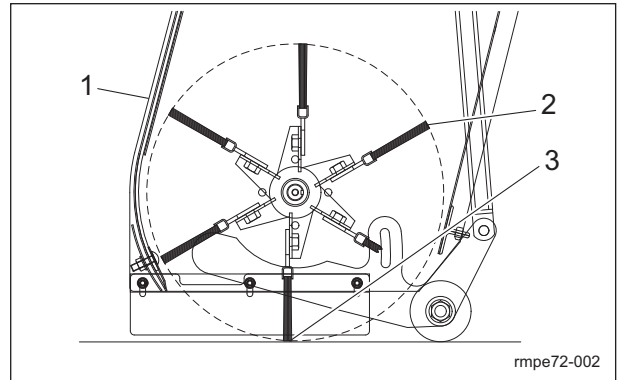

Adjustment of Brush Operation Height_002

1	Brush frame
2	Brush
3	Lowest point

5. Remove the retaining pin and locking pin.

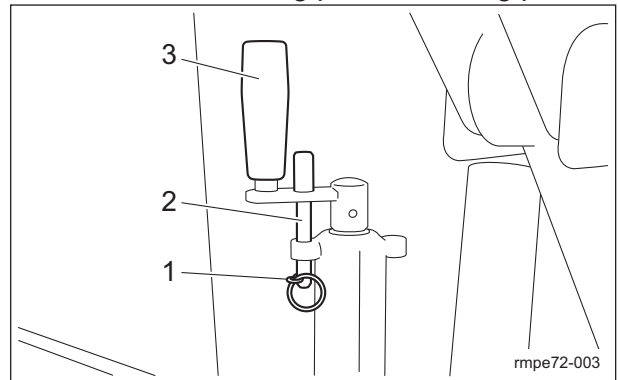

Adjustment of Brush Operation Height_003

1	Retaining pin
2	Locking pin
3	Brush adjusting handle

Important

Adjust the brush so that the left and right sides are even.

6. Turn the brush adjusting handle to raise the brush to approximately 6 mm (0.24 in) [cutting height+3 mm (0.12 in)]. Turning the handle to the right (clockwise) lowers the brush. Turning the handle to the left (counterclockwise) raises the brush.

Handling Instructions

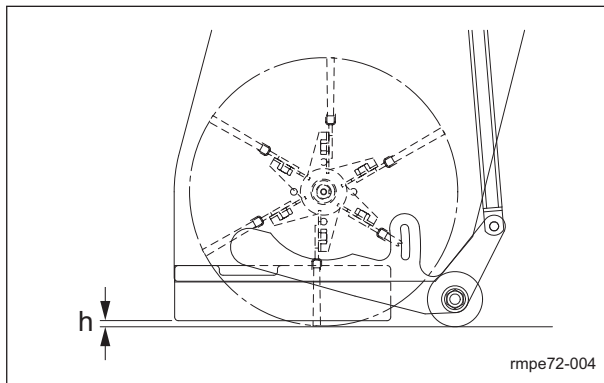

Adjustment of Brush Operation Height_004

h	Brush height
---	--------------

7. Re-place the locking pin and retaining pin.
8. Perform actual work, and gradually adjust the brushes to the appropriate collection position.
Check with an adjustment at every half turn.

Procedure to Start/Stop Engine

Start/Stop of Engine

Procedure to Start Engine

⚠ Caution

Do not start the engine in a building with insufficient ventilation.

⚠ Caution

Before starting the engine, make sure that there are no other people or obstacles around the machine.

⚠ Caution

Make sure that the covers are correctly in place and are not damaged.

Important

Starter operation must take 15 seconds or less. If the engine does not start, stop using the battery for 30 to 60 seconds to avoid exhausting the battery.

1. Open the fuel cock.
This is near the fuel tank.
2. Sit on the seat.
3. Make sure that the parking brake is applied.
4. Make sure that the traveling pedal is in neutral position.

5. Move the throttle lever to the middle position between "High" and "Low".
6. Pull the choke knob.
Pull the choke knob half way for restarting, as necessary.
7. Switch the ignition key to the "START" position.

Important

Quickly returning the ignition key from the "START" position to the "ON" position may result in damage to the machine.

8. When the starter starts rotating and the engine starts, slowly return the ignition key to the "ON" position.
9. Check that the engine has started, and then return the choke knob to its original position.
10. Shift the throttle lever to "Low", and then warm up the engine for 1-2 minutes.
11. Gradually move the throttle lever to "High".

Procedure to Stop Engine

1. Lower the bucket to its lowest position.
2. Lower the brush frame.
3. Set the traveling pedal in neutral position.
4. Apply the parking brake.
5. Move the throttle lever to "Low", and continue idling for 1-2 minutes.
6. Switch the ignition key to the "OFF" position.
7. Make sure that the engine has stopped.
8. Remove the ignition key.
9. Leave the driver's seat.
10. Close the fuel cock.
The fuel cock is located near the fuel tank.

Handling Instructions

Safety Mechanisms

This machine features a safety device for starting/stopping the engine.

1. As for starting the engine, the safety device prevents the engine from starting unless it meets each of the following three conditions.

- An operator is sitting on the seat.
- The parking brake is applied.
- The traveling pedal is set to the neutral position.

2. In the event the operator leaves the seat with the engine running, the safety device will be activated and will stop the engine under any of the following conditions:

- The operator leaves the seat without applying the parking brake.
- The traveling pedal is operated after the parking brake is applied and the operator leaves the seat.

Operation Method

Cautions for when You Leave The Machine

⚠ Caution

If the brakes are not sufficiently effective, use the wheel stoppers to secure the machine.

⚠ Caution

Never park the machine on a slope.

1. Park the machine on level ground.
2. Apply the parking brake.
3. Stop the engine.
4. Remove the ignition key.
5. Leave the machine.

Positions of Operation Decals

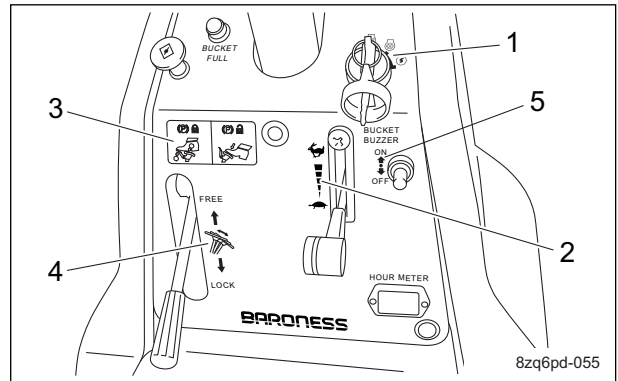

Positions of Operation Decals_001

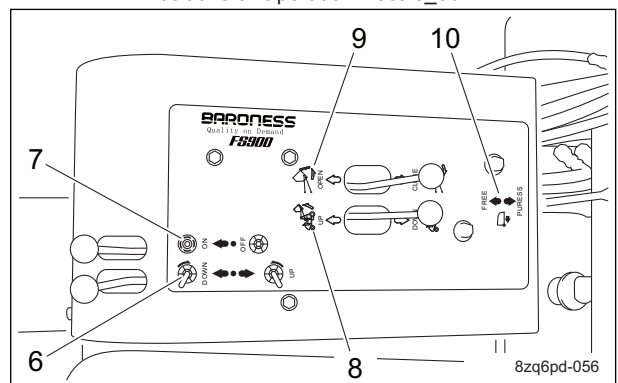

Positions of Operation Decals_002

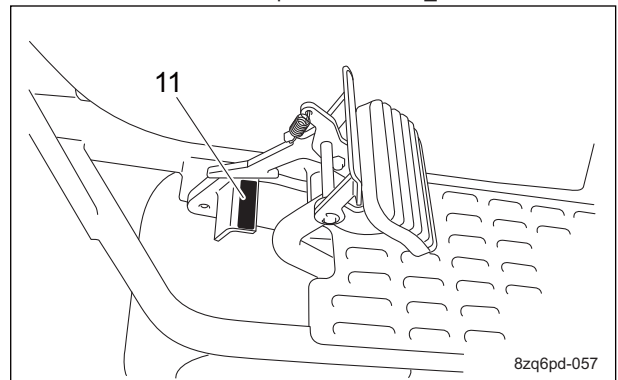

Positions of Operation Decals_003

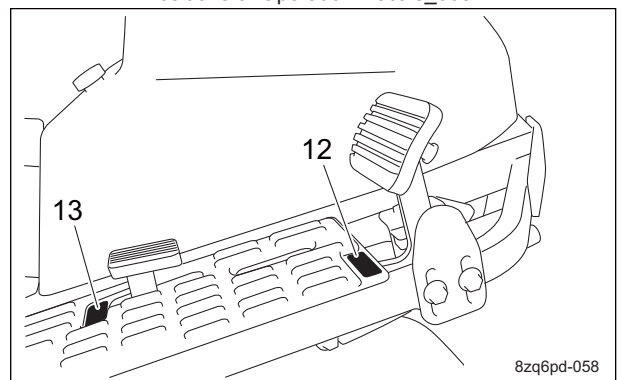

Positions of Operation Decals_004

Handling Instructions

1	Key switch mark
2	Engine rotation mark
3	Parking brake mark
4	Tilt steering mark
5	Bucket buzzer mark
6	Brush up/down mark
7	Brush rotation mark
8	Bucket up/down mark
9	Bucket open/close mark
10	Roller press mark
11	Brake decal
12	Forward decal
13	Backward decal

Description of Operation Decals

Key Switch Mark

Key switch mark
It illustrates the position of the key switch.

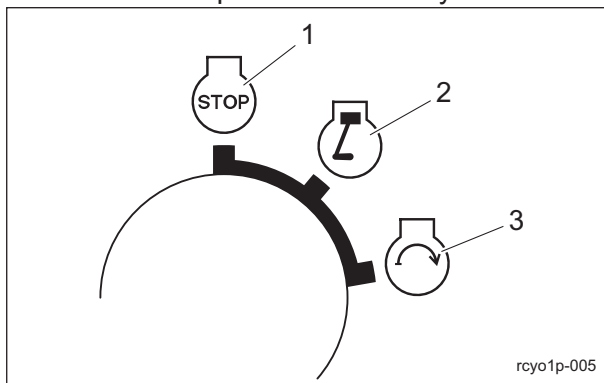

Key Switch Mark_001

1	OFF
2	ON
3	START

Engine Rotation Mark

Engine rotation mark
This indicates low/high speed of engine rotation.

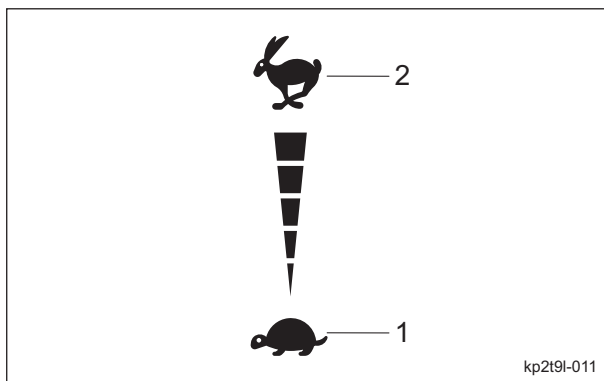

Engine Rotation Mark_001

1	Low speed
2	High speed

Parking Brake Mark

Parking brake mark
This indicates lock/release of the parking brake.

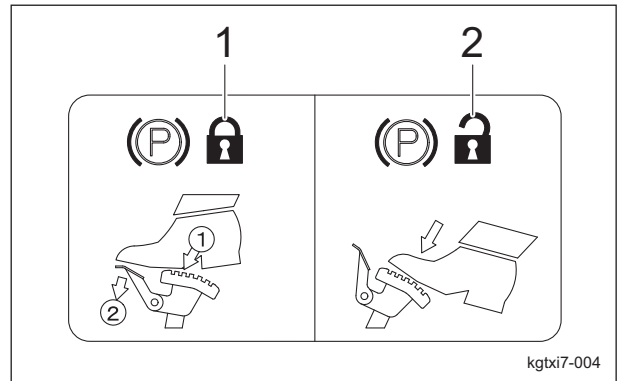

Parking Brake Mark_001

1	Lock
2	Release

Tilt Steering Mark

Tilt steering mark
This indicates the direction of tilt steering and lock/free of the position.

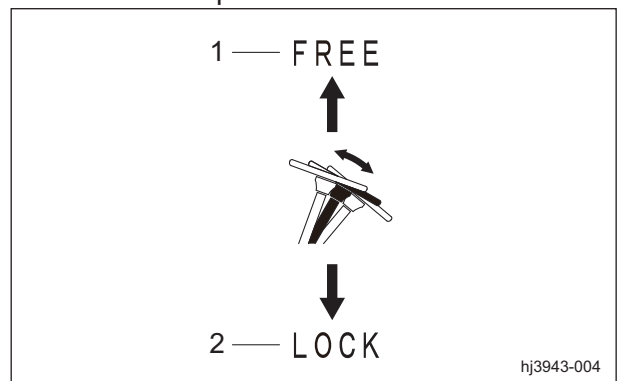

Tilt Steering Mark_001

1	FREE
2	LOCK

Handling Instructions

Bucket Buzzer Mark

Bucket buzzer mark
This indicates ON/OFF of bucket buzzer function.

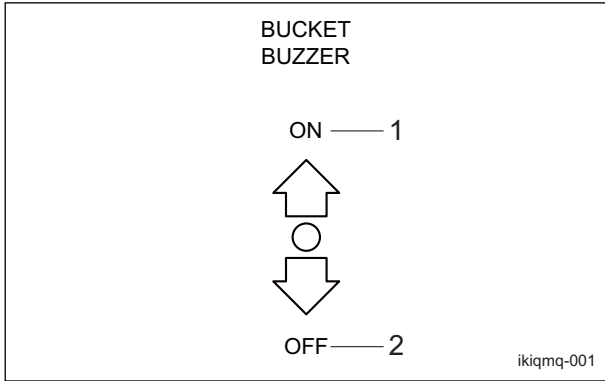

Bucket Buzzer Mark_001

1	ON
2	OFF

Brush Rotation Mark

Brush rotation mark
This indicates rotation/stop of the brush.

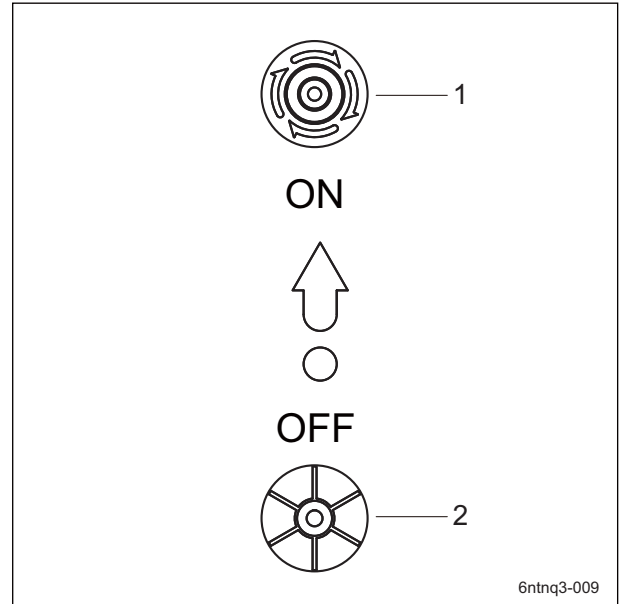

Brush Rotation Mark_001

1	Rotation
2	Stop

Brush Up/Down Mark

Brush up/down mark
This indicates Up/Down positions of the brush.

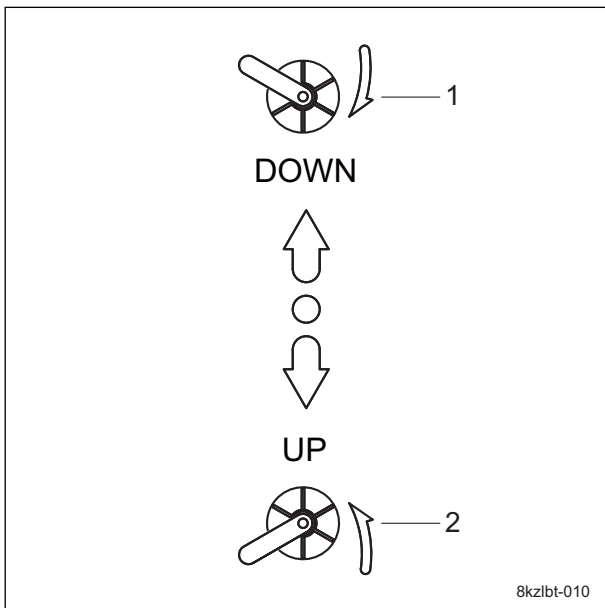

Brush Up/Down Mark_001

1	DOWN
2	UP

Bucket Up/Down Mark

Bucket up/down mark
This indicates up/down positions of the bucket.

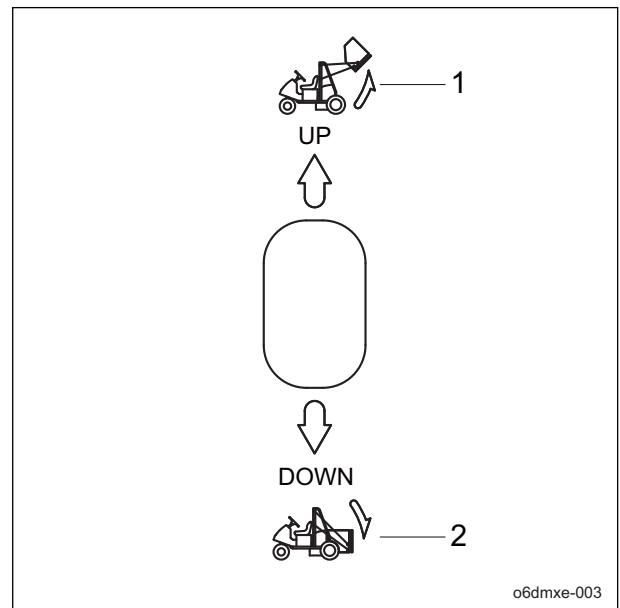

Bucket Up/Down Mark_001

1	Up
2	Down

Handling Instructions

Bucket Open/Close Mark

Bucket open/close mark
This indicates open/close positions of the bucket.

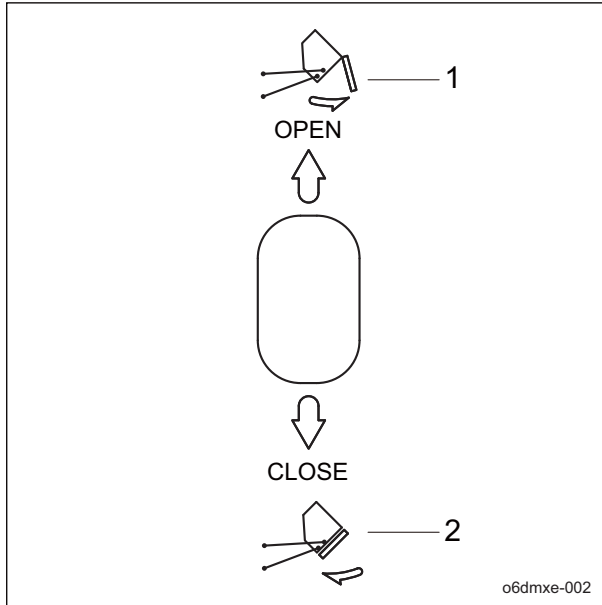

Bucket Open/Close Mark_001

1	Open
2	Close

Roller Press Mark

Roller press mark
This indicates statuses of roller functions.

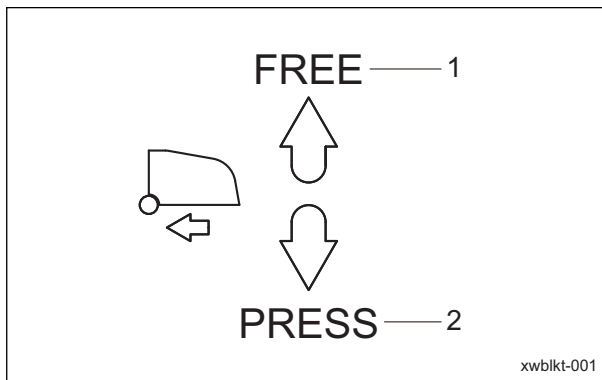

Roller Press Mark_001

1	Free
2	Press

BRAKE Decal

K4203001450
Decal, BRAKE
This indicates brake.



BRAKE Decal_001

FORWARD Decal

K4203001430
Decal, FORWARD
This indicates forward travel.



FORWARD Decal_001

BACKWARD Decal

K4203001440
Decal, BACKWARD
This indicates backward travel.

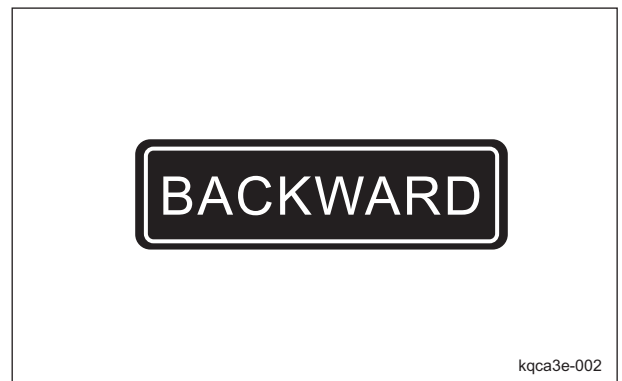

BACKWARD Decal_001

Handling Instructions

Traveling Pedal

The traveling pedal is located in the right foot area.

When depressed "Forward", the machine travels forward. When depressed "Backward", the machine travels in reverse.

If the pedal is secured with the speed adjustment plate during operation, the machine can be operated at a constant speed.

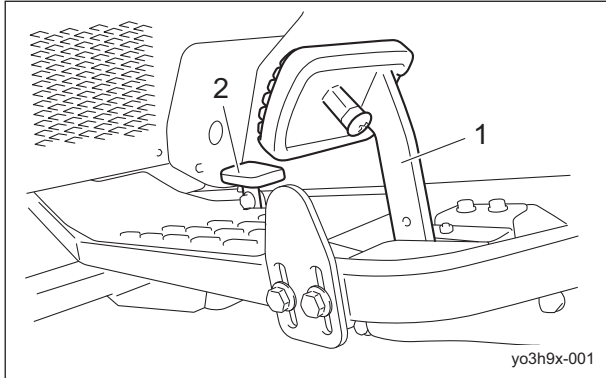

Traveling Pedal_001

1	Forward
2	Backward

Brake Pedal

Caution

Do not park the machine on a slope.

Caution

In case of the hydraulic brake malfunction, stop with the foot brake.

The brake pedal is located in the left foot area. To stop the machine, depress the brake pedal all the way firmly.

When parking, depress the locking pedal while firmly depressing the brake pedal to lock it.

To release the brake pedal, firmly depress the brake pedal to release the locking pedal.

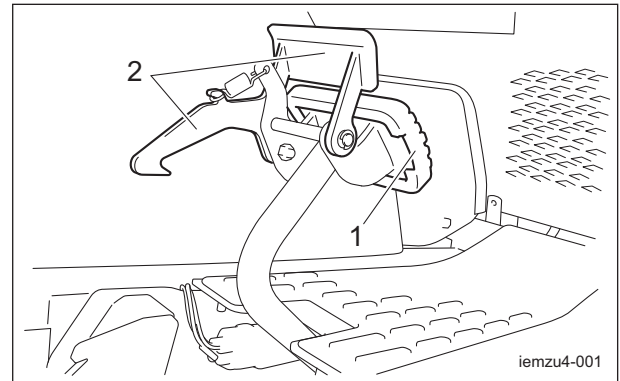

Brake Pedal_001

1	Brake pedal
2	Locking pedal

Throttle Lever

The throttle lever is located below the steering wheel, on the right, and enables you to adjust the engine rpm.

Move the throttle lever toward "High speed" to increase the engine rpm, and toward "Low speed" to decrease the rpm.

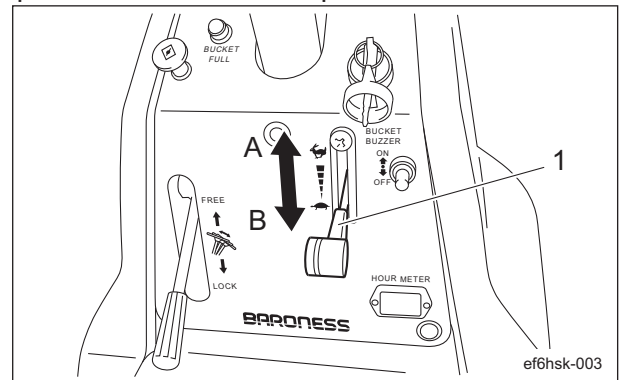

Throttle Lever_001

1	Throttle lever
A	High speed
B	Low speed

Handling Instructions

Choke Lever

The choke lever is located on the left side below the steering wheel and its knob is to be pulled when starting the engine. Pull the knob half way for restarting, as necessary.

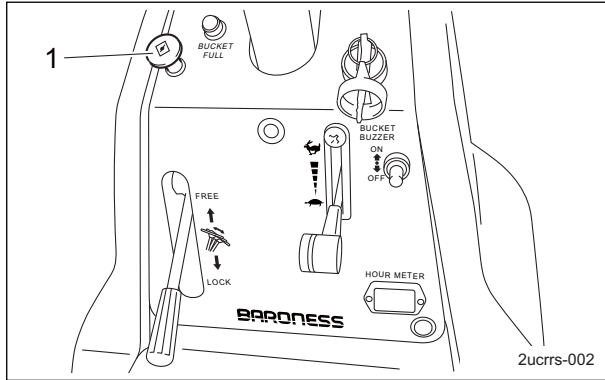

Choke Lever_001

1	Choke lever
---	-------------

Brush Up/Down Lever

The brush up/down lever is located to the right of the driver's seat and is used when performing core collection and sweeping.

- When the brush up/down lever is shifted to the "UP" position, the brush frame is raised. It stops when you release the lever. However, the brush frame can not be raised while the brush is rotated.
- When the brush up/down lever is shifted to the "DOWN" position, the lever is held in place, and the brush frame is lowered into the free position.
- When the brush up/down lever is returned to the neutral position, the up/down movement of the brush frame stops.

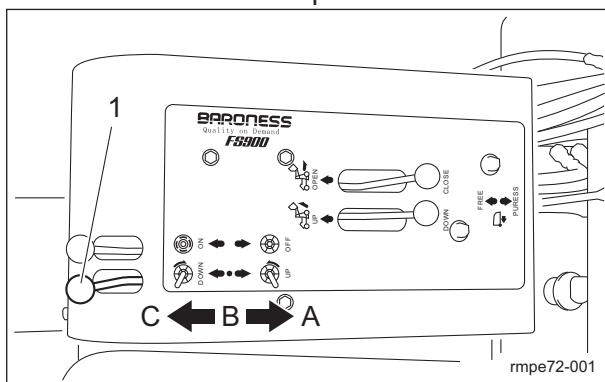

Brush Up/Down Lever_001

1	Brush up/down lever
A	Up
B	Neutral
C	Down

Brush Rotation Lever

The brush rotation lever is located to the right of the driver's seat and is used when performing core collection and sweeping.

- When the brush rotation lever is shifted to the "ON" position, the brushes and rotary plates are rotated.
- When the brush rotation lever is shifted to the "OFF" position, rotation is stopped.

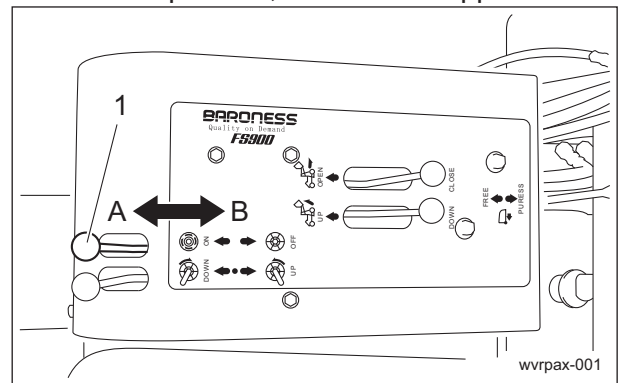

Brush Rotation Lever_001

1	Brush rotation lever
A	Rotate
B	Stop

Handling Instructions

Bucket Up/Down Lever

Warning

Do not raise the bucket on soft ground, an uneven surface or a slope. Otherwise, the main vehicle will become unbalanced and fall down.

Warning

Before raising the bucket, stop the machine with the front and rear wheels directed straight forward. Otherwise, the main vehicle will become unbalanced, and may fall down.

Warning

Before raising the bucket, fix the outriggers in the positions for raising the bucket. Otherwise, the main vehicle will become unbalanced, and may fall down.

Warning

Do not travel with the bucket raised. Otherwise, the main vehicle will become unbalanced and fall down.

Warning

Do not repeat shifting the bucket up/down lever abruptly. Otherwise, the main vehicle will become unbalanced, and may fall down.

Caution

Do not raise and lower the bucket while people or obstacles are nearby. Otherwise, injuries may result.

Caution

Sit on the seat when raising or lowering the bucket.

The bucket up/down lever is located to the right of the driver's seat and is used when dumping collected material into a truck, etc. When the bucket up/down lever is shifted to the "UP" position, the bucket is raised. Release the lever after the bucket rises to its highest position and stops.

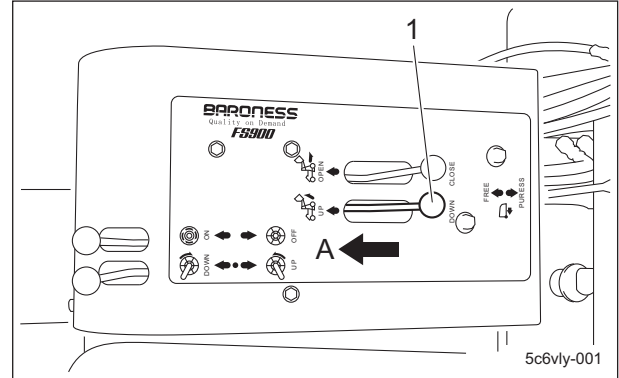

Bucket Up/Down Lever_001

1	Bucket up/down lever
A	Up

When the bucket up/down lever is shifted to the "DOWN" position, the bucket is lowered. Release the lever after the bucket lowers to its lowest position and stops.

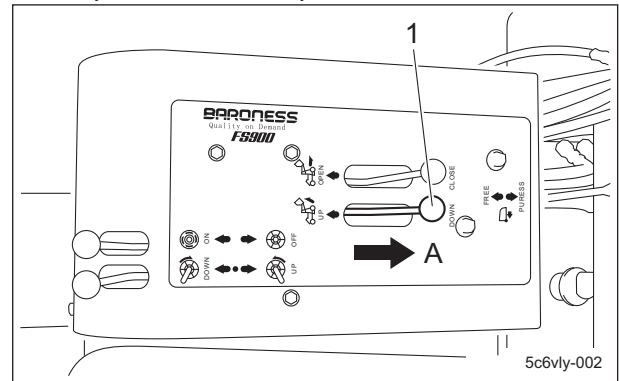

Bucket Up/Down Lever_002

1	Bucket up/down lever
A	Down

Handling Instructions

Bucket Open/Close Lever

The bucket open/close lever is located to the right of the driver's seat and is used when dumping collected material from the bucket.

1. When the bucket open/close lever is shifted to the "OPEN" position, the bucket is opened.
Release the lever when the bucket opens.

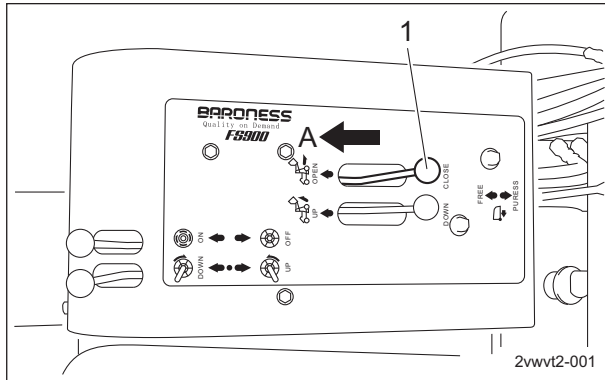

Bucket Open/Close Lever_001

1	Bucket open/close lever
A	Open

2. When the bucket open/close lever is shifted to the "CLOSE" position, the bucket is closed.

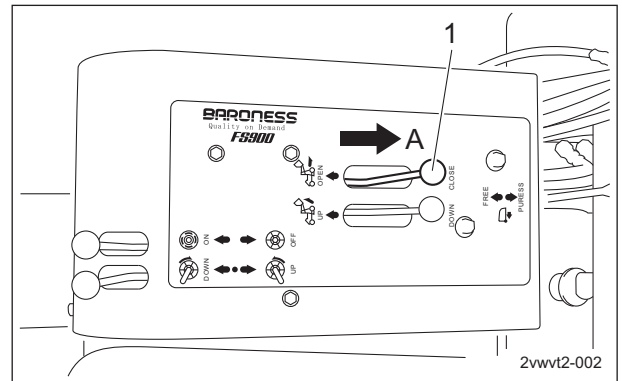

Bucket Open/Close Lever_003

1	Bucket open/close lever
A	Close

Roller Press Lever

The roller press lever is located to the right of the driver's seat and is used when performing core collection and compaction rolling.

Note:

If pressure is applied to the brush frame without the brushes being rotated, the machine can be used as a compaction roller.

- If the roller press lever is shifted to the "FREE" position, pressure is not applied to the brush frame and it is in the free position.
- If the roller press lever is shifted to the "PRESS" position, pressure is applied to the brush frame.

Important

To close the bucket lid, shift the bucket open/close lever to the "CLOSE" position and hold the lever position for 2 to 3 seconds. If the lever is released soon after shifted to the "CLOSE" position, the bucket lid will open and the collected cores, etc. will slip out.

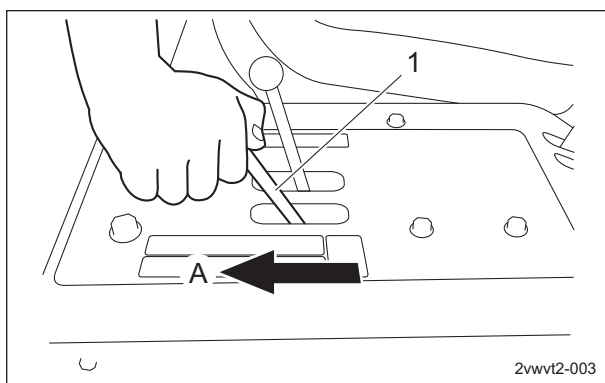

Bucket Open/Close Lever_002

1	Bucket open/close lever
A	Close

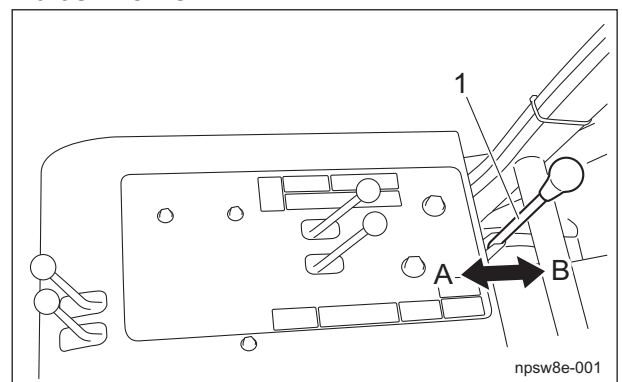

Roller Press Lever_001

1	Roller press lever
A	Free
B	Press

Handling Instructions

Urethane Tires

Note:
Depending on the specifications, this function may not be available.

Important

Travel slowly on bumpy or uneven ground. Otherwise cracks will develop in the urethane tires.

Important

Sudden acceleration, sudden braking or abrupt handling while traveling on paved roads will result in cracks, etc., in the urethane tires.

Important

Driving over curbs or tree roots will result in cracks, etc., in the urethane tires.

The front and rear wheels are equipped with urethane tires.
By utilizing the restoring characteristic of urethane foam, the pressure applied to lawns can be reduced by half, compared with the regular air-filled tires.

Outrigger

The outriggers are located behind the right and left wheels and used in the following cases. When using the outriggers, choose the appropriate position of hole for the purpose.

		Hole position	
		Bumper	Outrigger
1	For traveling and collecting	High	Low
2	For raising the bucket	High	Middle
3	For storage	Low	High

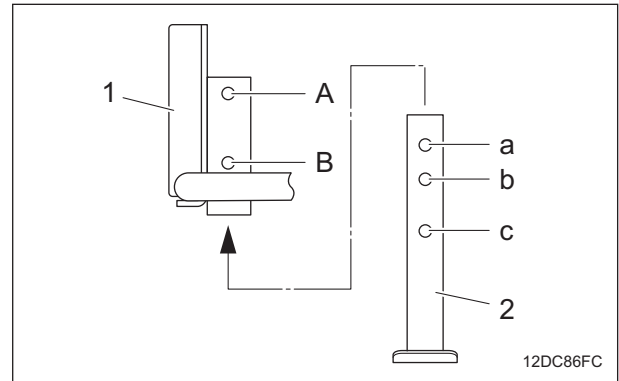

Outrigger_001

1	Bumper
2	Outrigger
A	High
B	Low
a	High
b	Middle
c	Low

1. For traveling and collecting :
 - [1] Pull out the clip pin and remove the pin.
 - [2] Align the holes of the outrigger and bumper on both sides.
 - [3] Insert the pin and attach the clip pin.
 - [4] Make sure that the outriggers are fixed and not in contact with the ground.

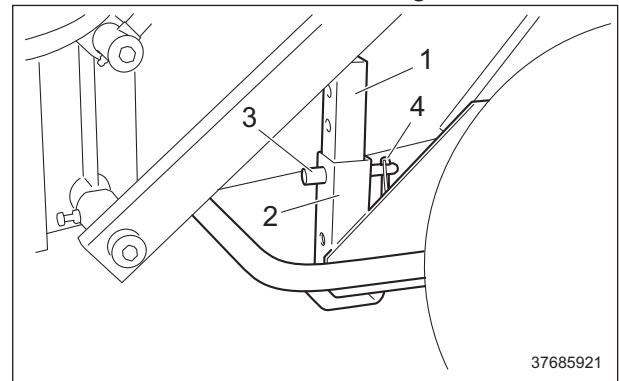

Outrigger_002

1	Outrigger
2	Bumper
3	Pin
4	Clip pin

Handling Instructions

2. For raising the bucket :

Important

Be sure to extend the outriggers on both sides.
The outriggers increase stability of the main vehicle to prevent its rollover when raising the bucket.

- [1] Pull out the clip pin and remove the pin.
- [2] Align the holes of the outrigger and bumper on both sides.
- [3] Insert the pin and attach the clip pin.
- [4] Make sure that the outriggers are fixed.

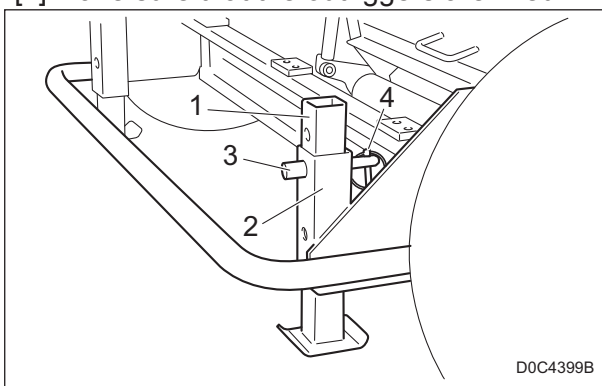

Outrigger_003

1	Outrigger
2	Bumper
3	Pin
4	Clip pin

3. For storage:

Important

When urethane tires are installed, storing the machine without the tires lifted off the ground will result in the tires becoming deformed.

- [1] Place the jacks beneath the right rear frame area and the left rear frame area, and then lift the machine off the ground. "Jack-up Points" (Page 5-5)
- [2] Pull out the clip pin and remove the pin.
- [3] Align the holes of the outrigger and bumper on both sides.
- [4] Insert the pin and attach the clip pin.
- [5] Slowly lower the jacks.

- [6] Make sure that the outriggers are fixed and that the rear tires are off the ground.

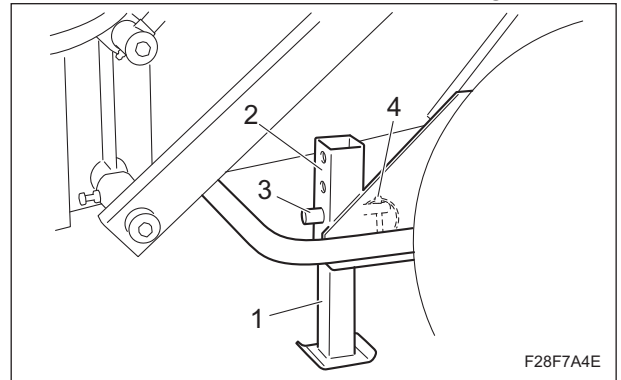

Outrigger_004

1	Outrigger
2	Bumper
3	Pin
4	Clip pin

Cylinder Lock

The cylinder lock is used for working under the raised bucket.

Warning

To keep the position of raised bucket, be sure to lock it with the cylinder lock.

- 1. Remove the cotter pin and round head pin, and then lower the cylinder lock.

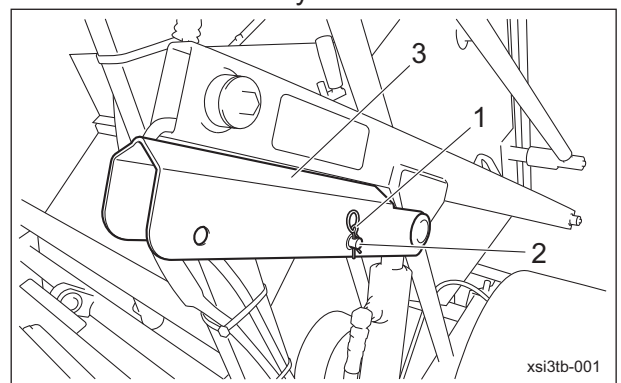

Cylinder Lock_001

1	Cotter pin
2	Round head pin
3	Cylinder lock

Handling Instructions

2. Insert the round head pin through the holes in the cylinder lock, and then install the cotter pin.

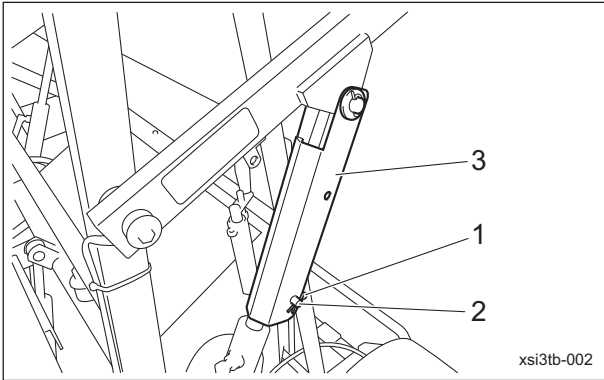

Cylinder Lock_002

1	Cotter pin
2	Round head pin
3	Cylinder lock

2. Raise the seat and make sure that the underseat cover stay is applied for locking. Make sure that the underseat cover remains open and then release your hand.

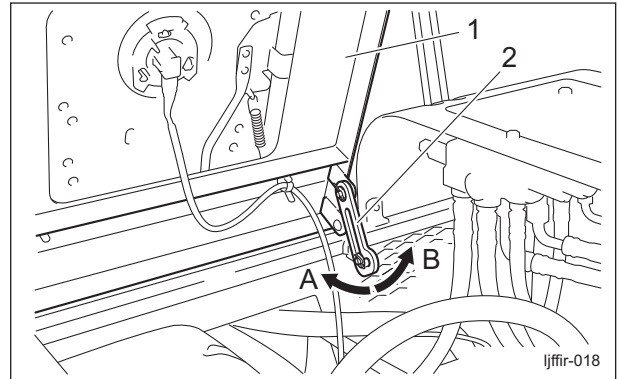

Underseat Cover_002

1	Underseat cover
2	Underseat cover stay
A	Lock
B	Release

Underseat Cover



Caution

Do not open the underseat cover in strong winds.



Caution

Be careful not to pinch your fingers when you open or close the underseat cover.

1. Remove the bolt.

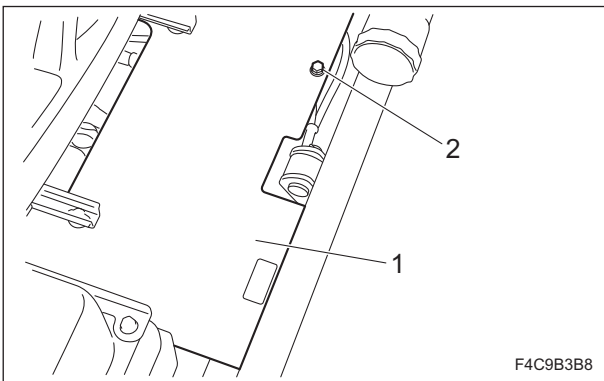

Underseat Cover_001

1	Underseat cover
2	Bolt

3. Release locking by the underseat cover stay and then close the underseat cover slowly.

Warning Buzzer Switch

The warning buzzer switch is located in the upper-right corner of the operation panel and is set to the "ON" position when the machine is operated.

When set to the "ON" position, a buzzer sounds and a warning lamp is turned on if the collections reach the bucket capacity.

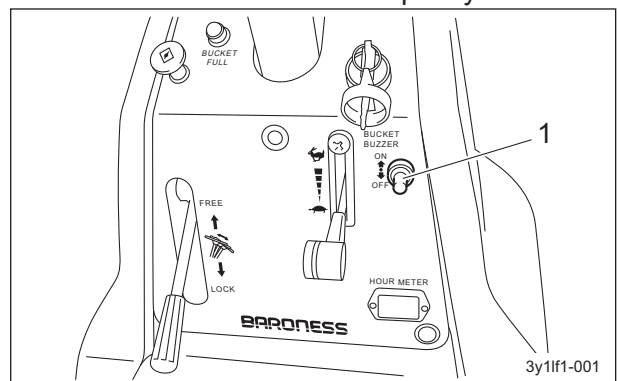

Warning Buzzer Switch_001

1	Warning buzzer switch
---	-----------------------

Handling Instructions

Instruments

Instruments on the Operation Panel

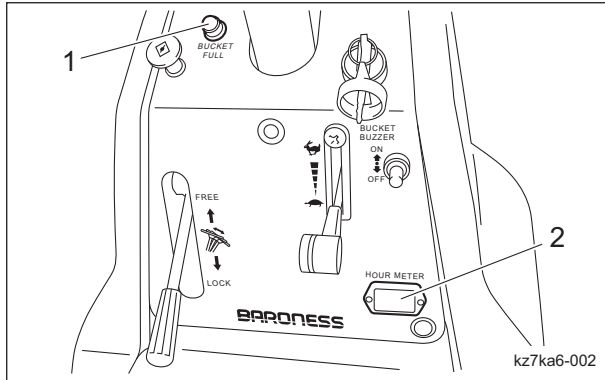

Instruments on the Operation Panel_001

1	Warning lamp
2	Hour meter

Warning Lamp

The warning lamp is located in the upper-left corner of the operation panel.

The lamp will light up in red if the collections reach the bucket capacity.

Hour Meter

The hour meter indicates the accumulated operation time of the engine.

The number in red figures on a white background is incremented every thirty-six seconds.

The number in white figures on a black background is incremented every hour.
1/100 wheel ... red figures on a white background

Hour wheel ... white figures on a black background

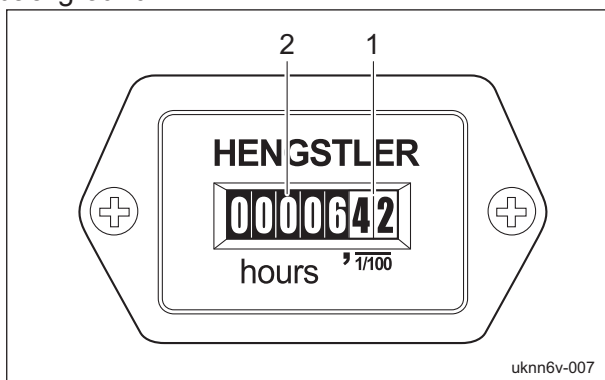

Hour Meter_001

1	1/100 wheel
2	Hour wheel

Angle Meter

The angle meter is located in the operation panel.

This instrument indicates the angle of the machine position.

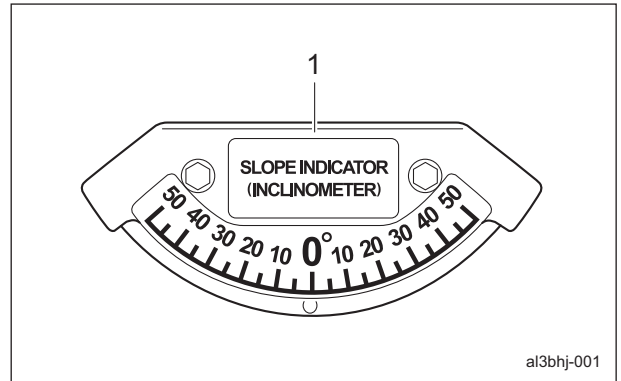

Angle Meter_001

1	Angle meter
---	-------------

Move

Traveling Operation

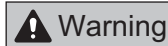

Warning

Do not travel with the bucket raised.



Caution

Under any circumstances drive the machine at such a speed that you can stop it immediately for emergencies.



Important

Do NOT start to move or stop the machine abruptly.
It will damage the hydraulic system or result in oil leakage.

- Before starting the engine, check the following points.
 - An operator must be sitting on the seat.
 - The parking brake lever must be applied.
 - The traveling pedal must be set to the neutral position.
- Start the engine.
- Raise the brush frame.
- Firmly depress the brake pedal to release the locking pedal to release parking brake.
- Slowly depress the traveling pedal.
- The machine starts traveling.

Handling Instructions

- The machine stops slowly when the foot leaves the traveling pedal.

Towing the Machine

If the machine does not travel due to engine trouble, etc., you can move it in the following ways:

- Pushing by hand
- Towing (See the following instruction.)

Caution

Unless you plan to tow the machine, raise the bolts so they do not contact the unload valve operating pins, and then tighten the lock nuts firmly.

Caution

Before restarting the engine, be sure to close the unload valve.

Important

When towing the machine, travel at a speed no more than 3.0 km/h. In addition, do not tow the machine for more than 3 minutes. If the towing speed is too fast or the machine is towed too much, the pump or motor will be damaged.

- Stop the engine.
- Apply the parking brake.
- Chock the wheels.
- Secure the rope to the front part of the frame.

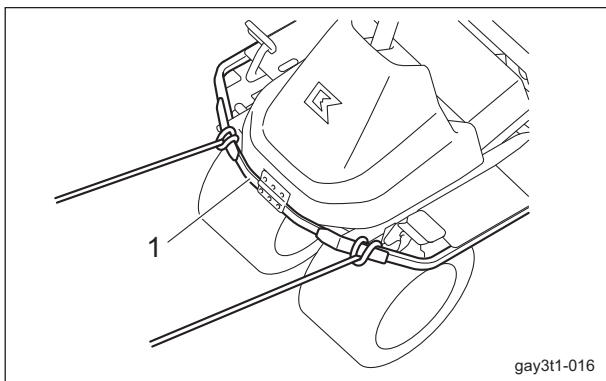

Towing the Machine_001

1	Frame
---	-------

- Open the underseat cover.

- Loosen the lock nut.

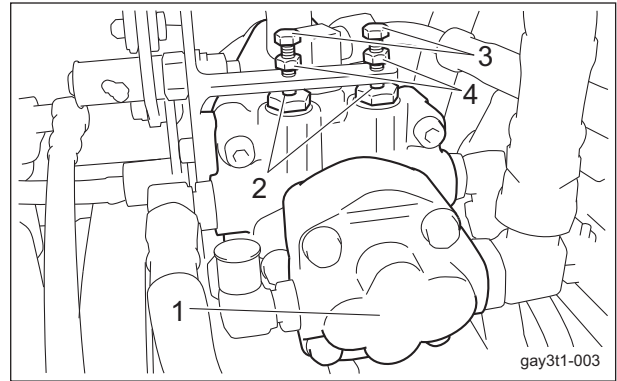

Towing the Machine_002

1	Piston pump
2	Unload valve operating pin
3	Bolt
4	Lock nut

Important

When compressing the unload valve operating pins, be careful not to overtighten the bolts. Otherwise, the unload valve operating pins will be damaged.

- Tighten the bolts to compress the unload valve operating pins and open the unload valves.

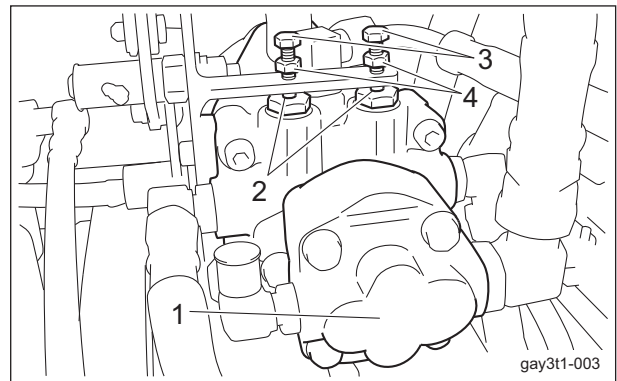

Towing the Machine_003

1	Piston pump
2	Unload valve operating pin
3	Bolt
4	Lock nut

Important

Before towing, be sure to open the unload valves at the two locations.

- Close the underseat cover.
- Release the chocks.

Handling Instructions

10. Release the parking brake.

Warning

While towing, always keep your foot on the brake pedal and depress the brake pedal at any time to stop.

11. Tow the machine slowly.

Operations

Collecting Operation

Caution

Make sure that the bucket lid is closed.

Caution

Collection work must be performed at an appropriate speed for the site and location. When collecting over bumpy surfaces, keep the engine rpm steady, and slow down the speed.

Caution

Before beginning collection work, be sure to perform a safety check of the intended work area.

Important

Do NOT start to move or stop the machine abruptly. It will damage the hydraulic system or result in oil leakage.

1. Before starting the engine, check the following points.
 - An operator must be sitting on the seat.
 - The parking brake lever must be applied.
 - The traveling pedal must be set to the neutral position.
2. Start the engine.
3. Raise the brush frame.
4. Firmly depress the brake pedal to release the locking pedal to release parking brake.
5. Shift the throttle lever to the "High speed" position, and rev up the engine to MAX.

Caution

If the full bucket warning buzzer sounds and the warning lamp is turned on, immediately stop collection work.

6. Set the warning buzzer switch to the "ON" position.

Important

When working on a lawn, rotating the brushes with the brush frame lowered while the machine is stopped may damage the lawn since it continues to be hit by the brushes.

7. Shift the brush rotation lever to the "ON" position to rotate the brushes.
8. Depress the traveling pedal to start traveling.
9. At the area where the operation is started, shift the brush up/down lever to the "DOWN" position.

Note:
During collection work, the lever is held in the "DOWN" position, and the brush frame is in the free position.
10. At the area where the operation is finished, shift the brush rotation lever to the "OFF" position to stop the brushes.
11. Shift the brush up/down lever to the "UP" position.
12. Repeat steps 7. to 11. to perform the collection work.
13. After finishing the collection work, shift the brush rotation lever to the "OFF" position to stop the brushes.

Handling Instructions

Dumping Operation

Danger

Do not perform dumping operation in dangerous areas, such as near cliffs.

Warning

Do not raise the bucket on soft ground, an uneven surface or a slope. Otherwise, the main vehicle will become unbalanced and fall down.

Warning

Before raising the bucket, stop the machine with the front and rear wheels directed straight forward. Otherwise, the main vehicle will become unbalanced, and may fall down.

Warning

Before raising the bucket, fix the outriggers in the positions for raising the bucket. Otherwise, the main vehicle will become unbalanced, and may fall down.

Warning

Do not travel with the bucket raised. Otherwise, the main vehicle will become unbalanced and fall down.

Warning

Do not repeat shifting the bucket up/down lever abruptly. Otherwise, the main vehicle will become unbalanced, and may fall down.

Warning

Before working under the bucket, stop the engine and lock the bucket with the cylinder lock.

Caution

Do not raise and lower the bucket and do not open and close the bucket lid while people or obstacles are nearby.

Otherwise, injuries may result.

1. Move the vehicle to a dumping area, and then back up to the dumping spot and park at a position to raise the bucket.
2. Apply the parking brake.
3. Fix the outriggers in the positions for raising the bucket.
4. Shift the bucket up/down lever to the "UP" position to raise the bucket. Release the lever after the bucket rises to its highest position and stops.
5. Release the parking brake.
6. Slowly back up to a position where the collected trash cannot slip out.
7. Apply the parking brake.
8. Shift the bucket open/close lever to the "OPEN" position to open the bucket. Release the lever when the bucket opens.
9. Make sure that the collected trash has been dumped.

Important

To close the bucket lid, shift the bucket open/close lever to the "CLOSE" position and hold the lever position for 2 to 3 seconds. If the lever is released soon after shifted to the "CLOSE" position, the bucket lid will open and the collected cores, etc. will slip out.

10. Shift the bucket open/close lever to the "CLOSE" position to close the bucket.
11. Release the parking brake.
12. Travel forward slowly to a position where the bucket can be lowered if needed.
13. Shift the bucket up/down lever to the "DOWN" position to lower the bucket. Release the lever after the bucket drops to its lowest position and stops.
14. Apply the parking brake.
15. Fix the outriggers in the position for traveling and collecting.

Handling Instructions

Transporting

Transporting Procedure

Important

When loading or unloading the machine, raise the bucket 10 cm (3.94 in). Otherwise, the bucket lid may hit a loading ramp etc.

When loading this machine into a trailer or a truck to transport it, drive the machine in reverse. When unloading, drive the machine forward.

After loading or unloading, lower the bucket to the lowest position.

Storage

Before Long-Term Storage

1. Cleaning
 - Remove dirt, grass clippings, oil stains etc. completely from the main vehicle and engine.
2. Replacing oil
 - Inspect and replace the engine oil, hydraulic oil and element.
3. Greasing and lubricating
 - Supply oil and apply grease to appropriate parts.
4. Battery
 - Remove the negative battery wire.
5. Fuel
 - Remove the fuel from the fuel tank.
6. Tire pneumatic pressure
 - Set the tire air pressure slightly higher than normal, and then place the machine on a board to avoid humidity.
7. Storage location
 - Cover the machine and store it in a dry place where it will not be exposed to rain.

Storage with Urethane Tires Installed

Important

When urethane tires are installed, storing the machine without the tires lifted off the ground will result in the tires becoming deformed.

- If the rear tires are urethane tires, use the supplied outriggers to raise the rear tires.

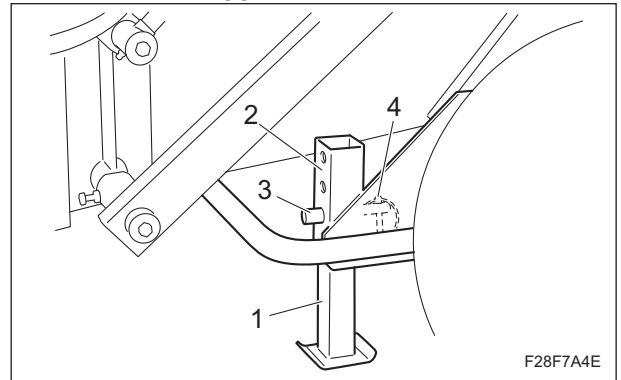

Storage with Urethane Tires Installed_001

1	Outrigger
2	Bumper
3	Pin
4	Clip pin

- If the front tires are urethane tires, use a block of wood to raise the front tires.

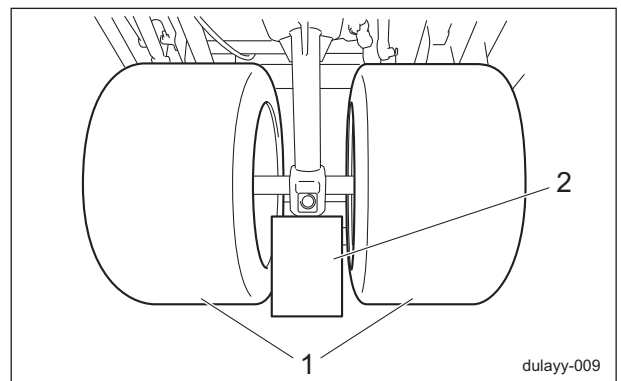

Storage with Urethane Tires Installed_002

1	Front tire
2	Block of wood

Handling Instructions

Maintenance Precautions	Page 5-2
Maintenance Schedule	Page 5-3
Adjusted Values	Page 5-4
Jacking Up The Machine	Page 5-5
About Jacking Up The Machine	Page 5-5
Jack-up Points	Page 5-5
Greasing	Page 5-6
About Greasing	Page 5-6
Greasing Points	Page 5-6
Lubrication	Page 5-9
About Lubrication	Page 5-9
Lubricating Points	Page 5-9
Maintenance Work	Page 5-10
Cleaning Sweeper Section	Page 5-10
Removing/Installing Tires	Page 5-10
Adjustment of Belt Tension	Page 5-11
Adjustment of Brake	Page 5-12
Adjusting the Neutral Position of the Piston Pump	Page 5-13
Adjustment of Front Apron	Page 5-14
Adjustment of Brushes	Page 5-15
Change of Brushes	Page 5-16
Adjustment of Rotary Plates	Page 5-17
Change of Rotary Plates	Page 5-19
Change of Hydraulic Oil	Page 5-20
Change of Hydraulic Oil Filter	Page 5-21
Change of Air Cleaner	Page 5-23
Change of Engine Oil	Page 5-24
Change of Engine Oil Filter	Page 5-25
Change of Fuel Filter	Page 5-25
Change of Fuse	Page 5-26

Maintenance

Maintenance Precautions

Warning

The chapter "Maintenance" in this manual describes practical measures which should be performed by a mechanic with expertise. The owner should instruct the mechanic with expertise to perform maintenance service for this machine.

Caution

First, learn well the maintenance operations you plan to perform.

Important

Use tools appropriate for each maintenance operation.

Important

For the safe and best performance of your machine, use Baroness genuine parts for replacement and accessories. Please note that our product warranty may be void if you use non-genuine parts for replacement or accessories.

Maintain the machine according to the maintenance schedule so that you will be able to take advantage of its optimum performance for a long period of time.

Maintenance Schedule

FS900

Follow the maintenance schedule below.

○ . . . Inspect, adjust, supply, clean

● . . . Replace (first time)

△ . . . Replace

Maintenance Item	Before Work	After Work	Every 50 hrs.	Every 100 hrs.	Every 250 hrs.	Every 400 hrs.	Every 500 hrs.	Every month	Every year	Every 2 years	Every 4 years	When Required	Remarks
Check hydraulic hoses (Moving part)	○												
Check V-belt damage	○												
Check brake wire	○												
Adjust front apron	○												
Grease and Lubricate all moving parts			○										
Check electrical wiring condition (Damage, defacement and joint looseness)			○	○									50 hours first change, every 100 hours thereafter
Check looseness of wheel mounting bolt			○	○									50 hours first change, every 100 hours thereafter
*1 Clean air cleaner element				○									Air cleaner should be cleaned more often in dusty conditions than in normal conditions
Clean fuel strainer				○									
*1 Change engine oil				△									
*1 Change engine oil filter				△									
*1 Change spark plug				△									
Change hydraulic oil				●			△						100 hours first change, every 500 hours thereafter
Change hydraulic suction filter				●			△						100 hours first change, every 500 hours thereafter
Change hydraulic oil line filter				●			△						100 hours first change, every 500 hours thereafter
*2 Check exterior of battery				○				○					Check every 100 hours or every month whichever comes earlier
*2 Clean exterior of battery				○				○					Check every 100 hours or every month whichever comes earlier
*2 Check mounting bracket of battery				○				○					Check every 100 hours or every month whichever comes earlier

Maintenance

Maintenance Item		Before Work	After Work	Every 50 hrs.	Every 100 hrs.	Every 250 hrs.	Every 400 hrs.	Every 500 hrs.	Every month	Every year	Every 2 years	Every 4 years	When Required	Remarks
*2	Check looseness and corrosion of battery terminals				○				○					Check every 100 hours or every month whichever comes earlier
*2	Check battery fluid level				○				○					Check every 100 hours or every month whichever comes earlier
	Check hydraulic hoses (Fixed part)				○				○					Check every 100 hours or every month whichever comes earlier
*1	Check valve clearance					○								
*1	Change air cleaner element						△			△				Change every 400 hours or every year whichever comes earlier
*1	Change fuel filter						△			△				Change every 400 hours or every year whichever comes earlier
*1	Change fuel hose and clamps										△			
*2	Change battery										△			
	Change hydraulic hoses (Moving part)										△			
	Change hydraulic hoses (Fixed part)											△		
	Change V-belt												△	
	Change traveling cable												△	
	Change brake shoe												△	
	Change brake wire												△	

- *1: Refer to the Engine's Owner's Manual.
- *2: Refer to the Battery's Owner's Manual.
- The values for consumables are not guaranteed.

Adjusted Values

Belt slack	Pump drive belt	Approx. 10 mm (0.39 in)	When belt pressed with 98 N (10 kgf) at the middle point between pulleys.
	Brush belt	Approx. 10 mm (0.39 in)	When belt pressed with 98 N (10 kgf) at the middle point between pulleys.

Jacking Up The Machine

About Jacking Up The Machine

Warning

When replacing a tire or beginning any other maintenance or repairs, be sure to chock the wheels to prevent the machine from moving. Before jacking up the machine, park it on a hard, flat surface such as a concrete floor and remove any obstacles that could prevent you from performing the work safely. When necessary, use an appropriate chain block, hoist, or jack. Support the machine securely with jack stands or appropriate blocks. Failure to do so may cause the machine to move or fall, resulting in injury or death.

Important

Only place a jack under the jack-up points specified. Placing a jack at any other point will result in damage to the frame or other parts.

Use the jack-up points identified in this manual when jacking up the machine.

Jack-up Points

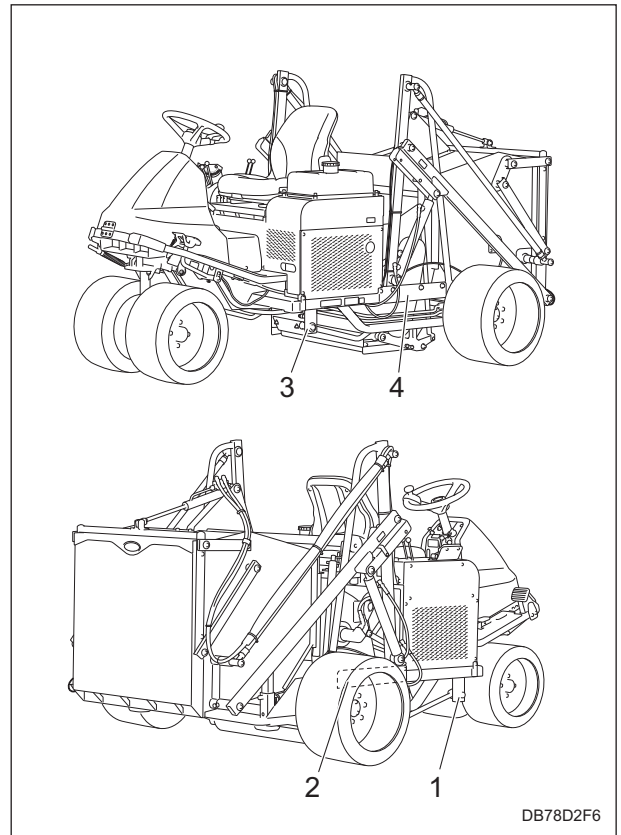

Jack-up Points_001

1	Right front brush frame mount area
2	Right rear frame area
3	Left front brush frame mount area
4	Left rear frame area

1. Right front brush frame mount area

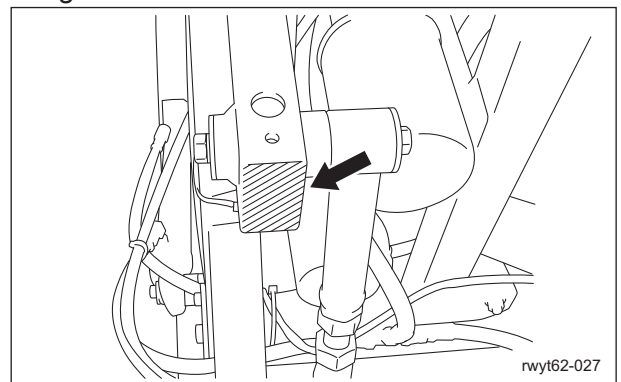

Jack-up Points_002

Maintenance

2. Right rear frame area

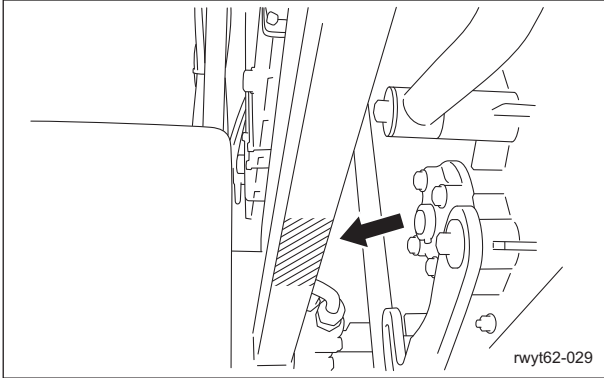

Jack-up Points_003

3. Left front brush frame mount area

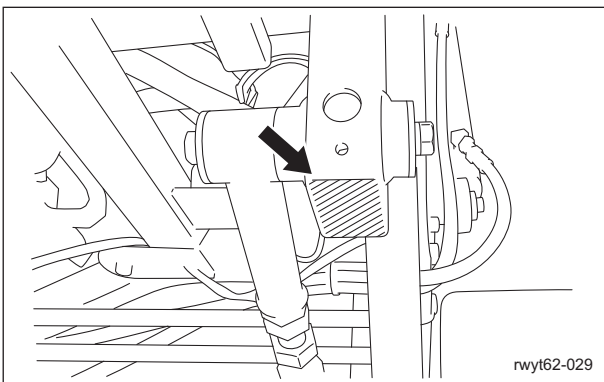

Jack-up Points_004

4. Left rear frame area

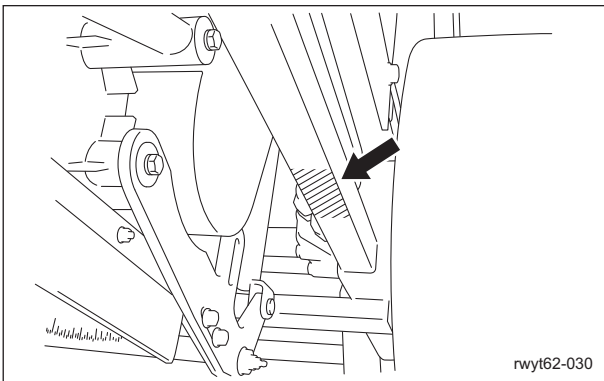

Jack-up Points_005

Greasing Points

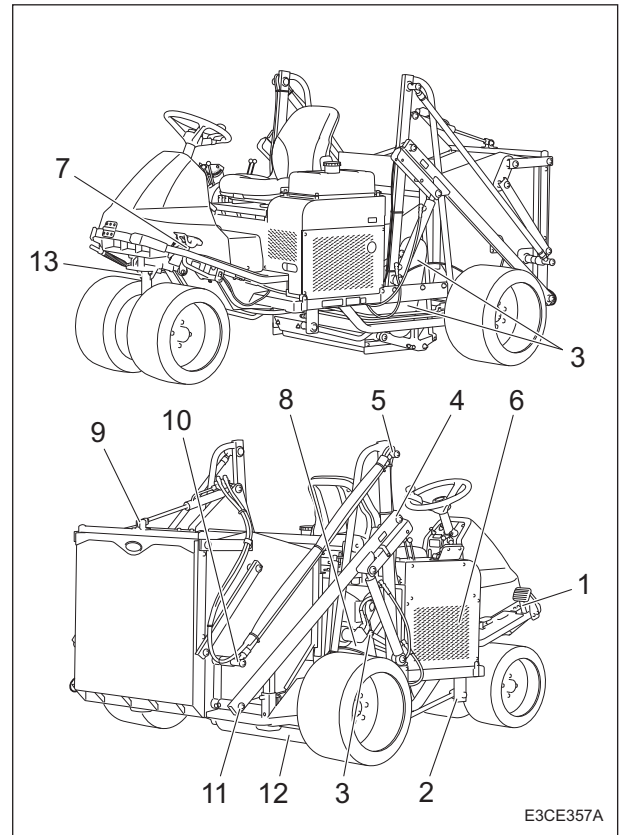

Greasing Points_001

	Location	No. of Greasing Points
1	Traveling pedal fulcrum	1
2	Brush frame fulcrum	2
3	Flange bearing	3
4	Upper connecting pipe	2
5	Upper adjusting pipe	2
6	Belt tension lever fulcrum (lower pulley for pump)	1
7	Brake pedal fulcrum	1
8	Pump neutral lever fulcrum (upper piston pump)	1
9	Bucket lid cylinder	1
10	Lower adjusting pipe	2
11	Lower connecting pipe	2
12	Rear roller	2
13	Front wheel arm	1

Greasing

About Greasing

Since there may be adhesion or damage due to lack of grease on moving parts, they must be greased.

Add urea-based No. 2 grease in accordance with the Maintenance Schedule.

Other locations where the specified grease or lubricant is used are indicated in "Greasing Points".

Add grease using the specified grease or lubricant.

1. Traveling pedal fulcrum

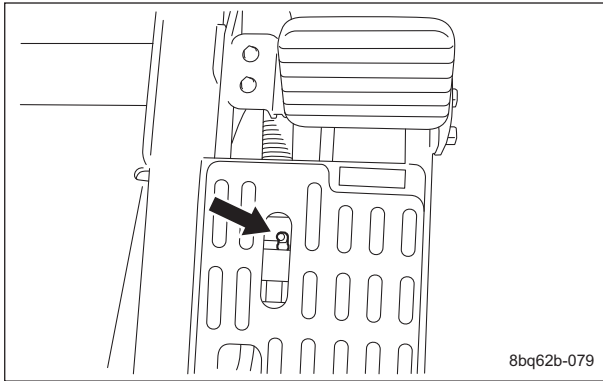

8bq62b-079

Greasing Points_002

Upper left

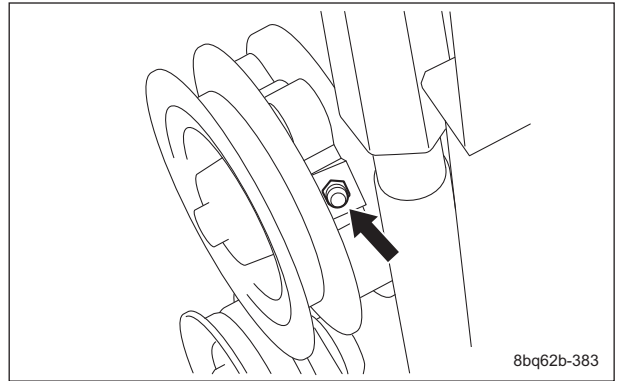

8bq62b-383

Greasing Points_005

2. Brush frame fulcrum

There is one point each on the left and right.

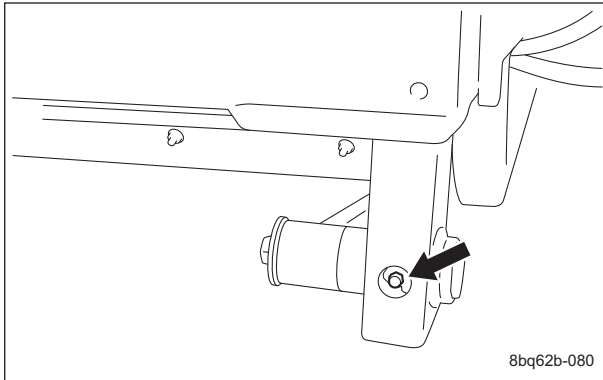

8bq62b-080

Greasing Points_003

Lower left

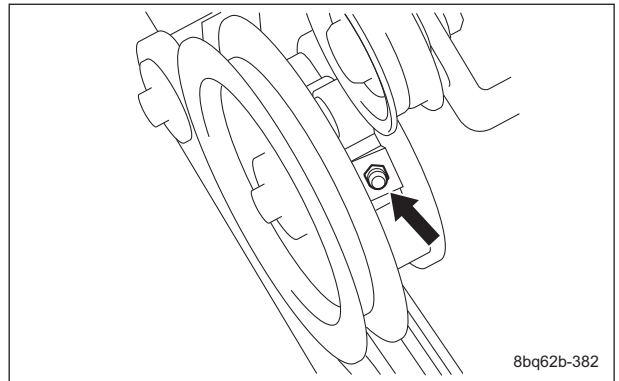

8bq62b-382

Greasing Points_006

3. Flange bearing

There are three points on the left and right.
Right

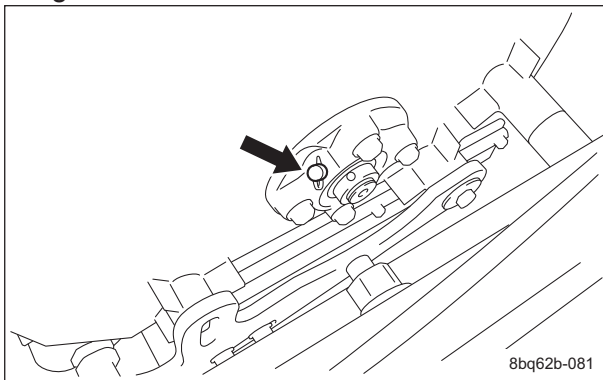

8bq62b-081

Greasing Points_004

4. Upper connecting pipe

There is one point each on the left and right.

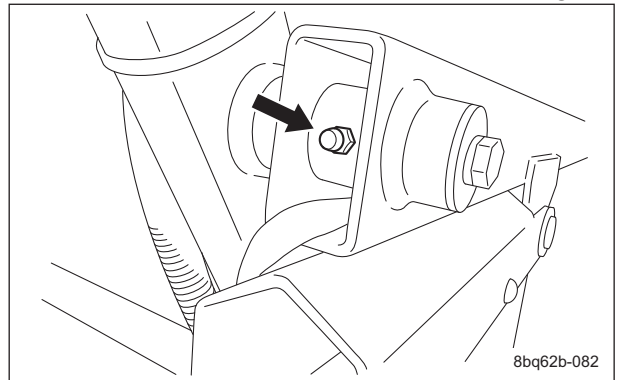

8bq62b-082

Greasing Points_007

Maintenance

5. Upper adjusting pipe
There is one point each on the left and right.

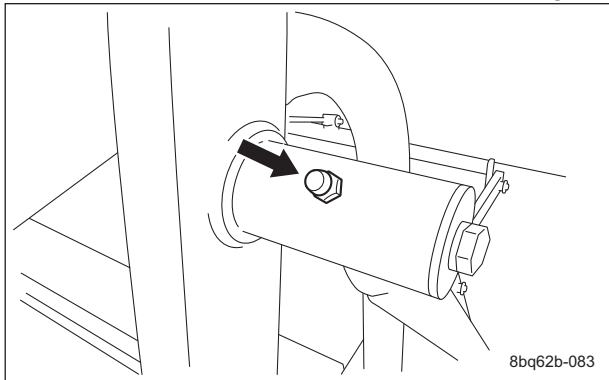

8bq62b-083

Greasing Points_008

8. Pump neutral lever fulcrum (upper piston pump)

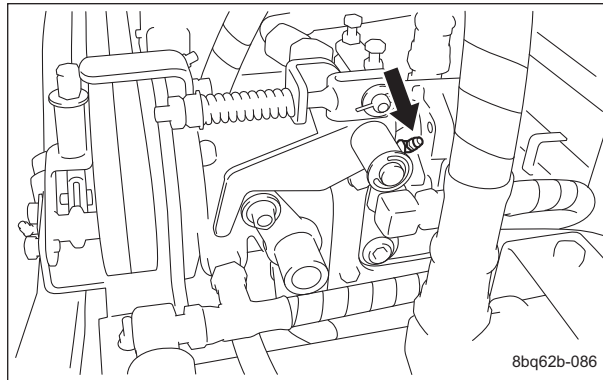

8bq62b-086

Greasing Points_011

6. Belt tension lever fulcrum (lower pulley for pump)

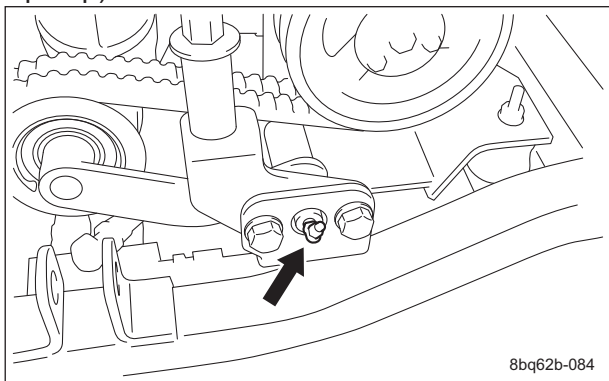

8bq62b-084

Greasing Points_009

9. Bucket lid cylinder

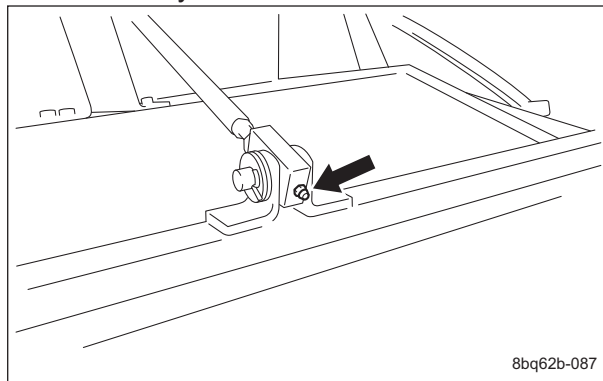

8bq62b-087

Greasing Points_012

7. Brake pedal fulcrum

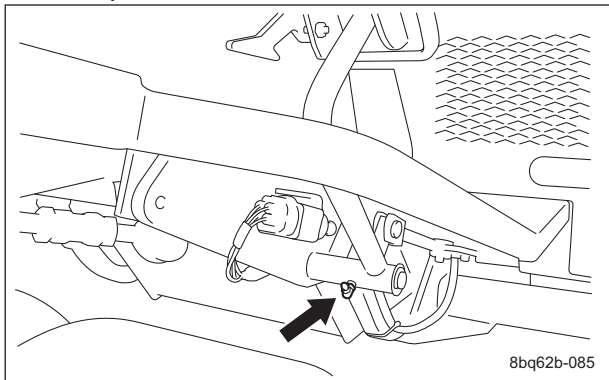

8bq62b-085

Greasing Points_010

10. Lower adjusting pipe
There is one point each on the left and right.

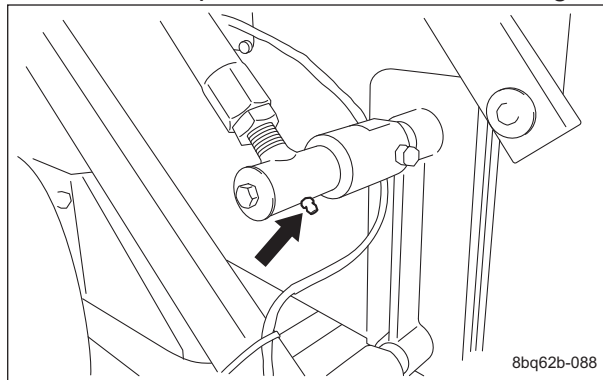

8bq62b-088

Greasing Points_013

11. Lower connecting pipe
There is one point each on the left and right.

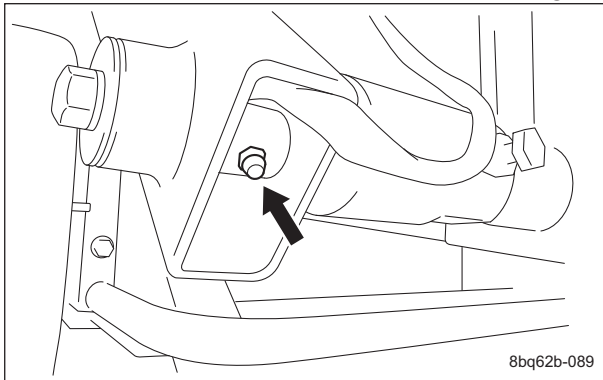

Greasing Points_014

12. Rear roller
There is one point each on the left and right.

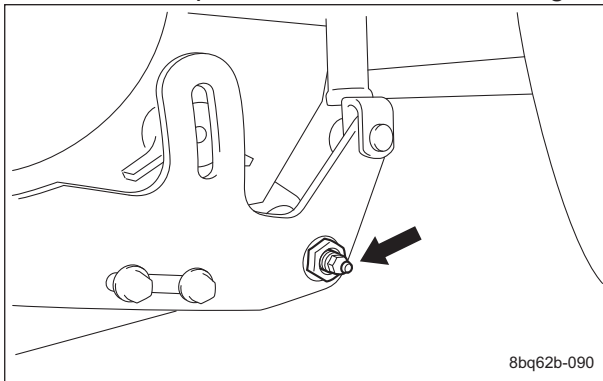

Greasing Points_015

13. Front wheel arm

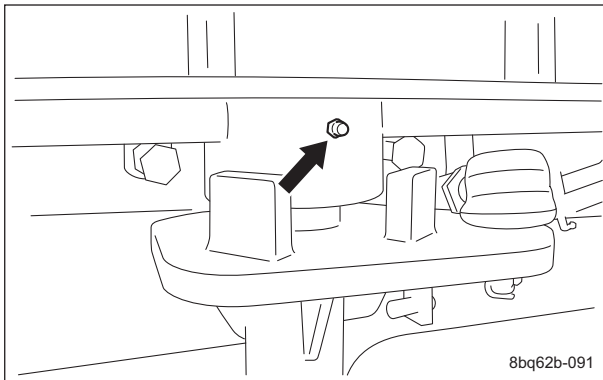

Greasing Points_016

Lubrication

About Lubrication

It is necessary to lubricate moving parts so that they will not become stuck or damaged. The locations where lubricant is used are indicated in "Lubricating Points". Apply the lubricant.

Lubricating Points

Apply lubricant at the following locations every 50 hours of operation.

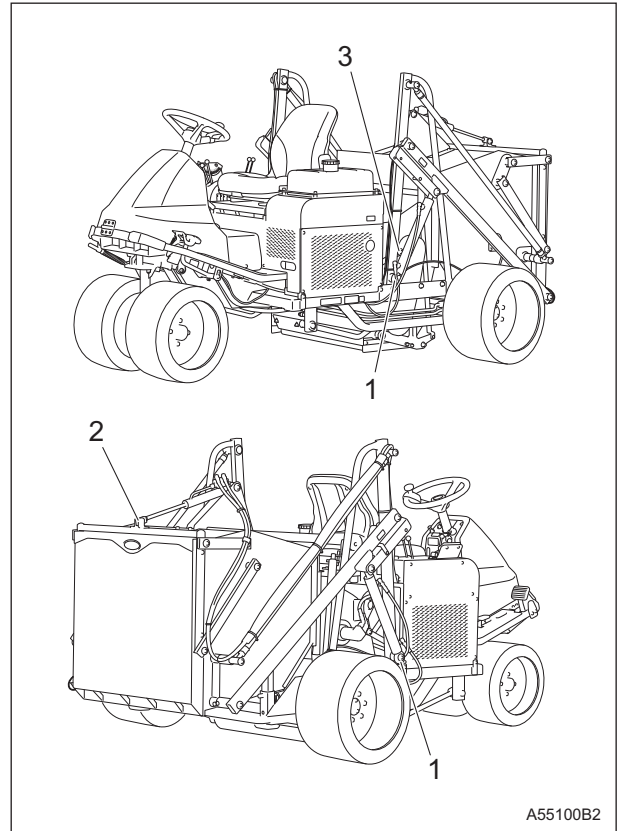

Lubricating Points_001

	Location	No. of lubricating points
1	Bucket up/down cylinder spherical bearing	2
2	Bucket lid open/close cylinder spherical bearing	1
3	Brush frame up/down cylinder spherical bearing	1

1. Bucket up/down cylinder spherical bearing
There is one point each on the left and right.

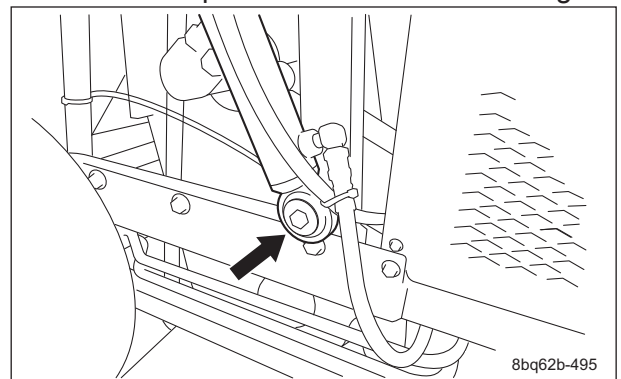

Lubricating Points_002

Maintenance

- Bucket lid open/close cylinder spherical bearing
There is one point.

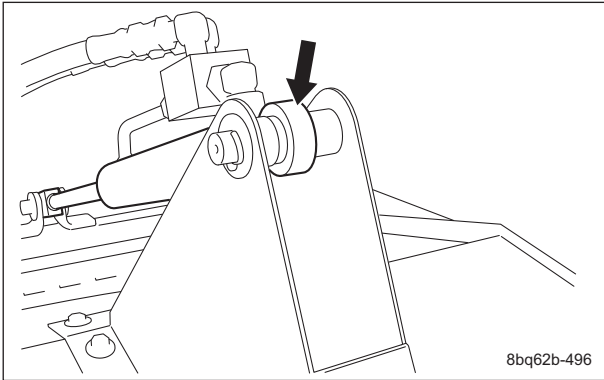

Lubricating Points_003

- Brush frame up/down cylinder spherical bearing
There is one point.

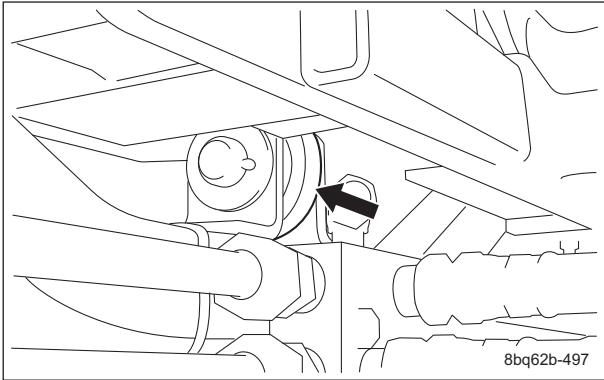

Lubricating Points_004

Maintenance Work

Cleaning Sweeper Section

Important

Dirty inside of the brush frame may reduce the collection capacity, causing premature wear of parts and abnormal vibration or damage due to high loads.
Be sure to wash parts with water.

Important

Do not wash the engine area, hydraulic section or battery area with water.

- Immediately after finishing work or on operation days, be sure to wash each part with water and dry them thoroughly.
- Be sure to supply oil to each of the greasing points.

Removing/Installing Tires

Front Tires

Follow the steps below to remove the front tires:

- Loosen the bolts.

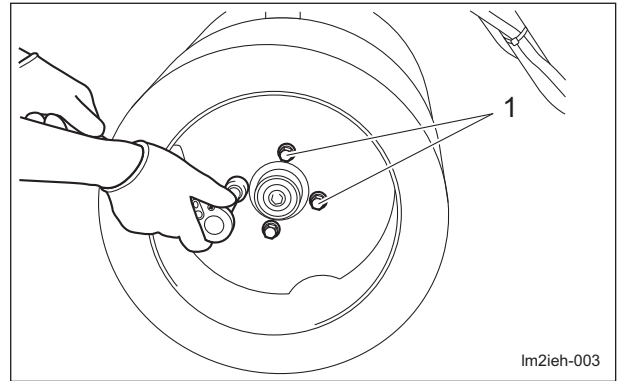

Front Tires_001

1	Heat-treated bolt
---	-------------------

- Securely place the jacks beneath the jack-up points of the left/right front brush frame mount areas, and then raise them until the tires lift off the ground.
"Jack-up Points" (Page 5-5)
- Remove the bolts.
- Remove the tire from the wheel mounting seat.

Important

Tighten the bolts in the tightening order (diagonally).

For installing the front tires, reverse the removing procedure.

Rear Tires

Follow the steps below to remove the rear tires:

- Loosen the bolts.

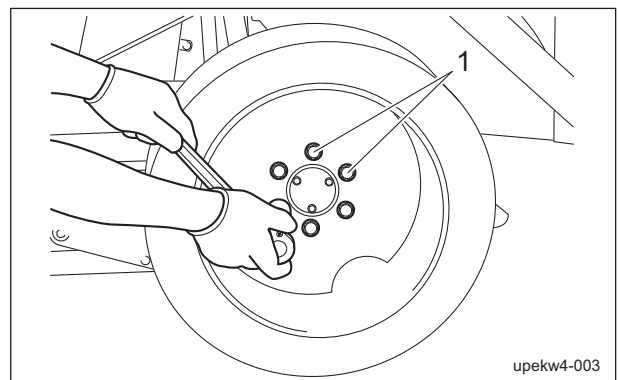

Rear Tires_001

1	Heat-treated bolt
---	-------------------

2. Securely place the jacks beneath the jack-up points of the rear left/right frame areas, and then raise them until the tires lift off the ground.
"Jack-up Points" (Page 5-5)
3. Remove the bolts.
4. Remove the tire from the wheel mounting seat.

Important

Tighten the bolts in the tightening order (diagonally).

For installing the rear tires, reverse the removing procedure.

Adjustment of Belt Tension

Warning

Be sure to stop the engine before adjusting the belts.

Important

Before making sure of belt tension, rotate the belt several times.

If the belt becomes slack due to frequent use, it may jump or slip.
In addition, if it is overtightened, it may wear prematurely.
If necessary, adjust it, and always check the belt for appropriate tension.

Adjustment of Pump Drive Belt

1. The belt tension is appropriate when there is approximately 10 mm (0.39 in) of slack when the belt is pressed lightly by finger at 98 N (10 kgf) around the center section between the belt pulleys (arrow in the diagram).

2. Tighten the high nut until there is no clearance between the spring cover and the tension fulcrum fitting, and then lock it in place with the nut.

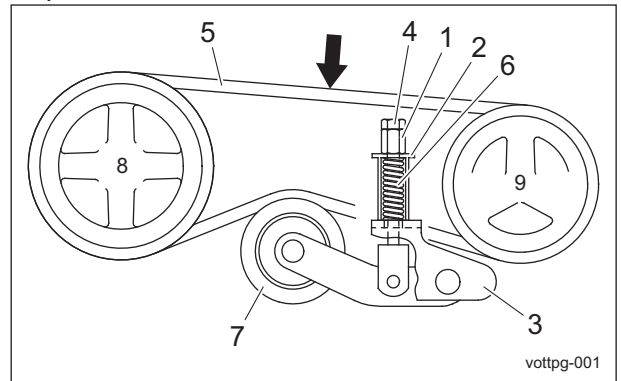

Adjustment of Pump Drive Belt_001

1	High nut
2	Spring cover
3	Tension fulcrum fitting
4	Nut
5	Belt
6	Spring
7	Tension pulley
8	Engine pulley
9	Pump pulley

Adjusting the Brush Belt

Important

If the brush belt is incorrectly adjusted, the brushes will not rotate properly.

1. Move the machine to level ground.
2. Depress the locking pedal while firmly depressing the brake pedal to lock it.
3. Lower the brush frame and the bucket.
4. Stop the engine.
5. Remove the four bolts, and then remove the belt cover.

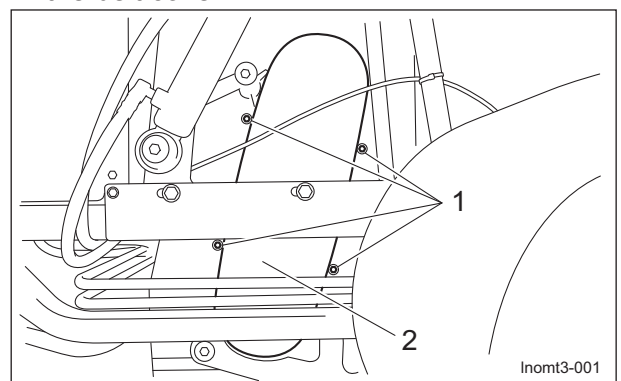

Adjusting the Brush Belt_001

Maintenance

1	Bolt
2	Belt cover

6. Loosen the bolt, and then tighten the nut to adjust the tension pulley.

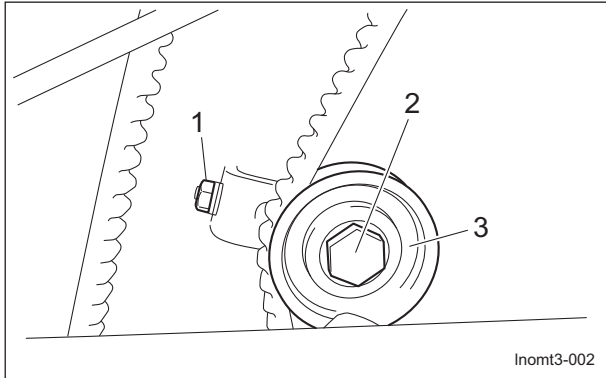

Adjusting the Brush Belt_002

1	Nut
2	Bolt
3	Tension pulley

7. The V-belt tension is appropriate when the belt slacks by approximately 10.0 mm (0.39 in) when you apply a force of 98 N (10 kgf) with your finger to the belt at the middle point.

8. Install the belt cover after adjustment.

Adjustment of Brake

⚠ Caution

If the brake wire is cut, the machine will be unable to stop.
 If the brake wire is cracked or damaged, replace it with a new one immediately.
 If the brake is not sufficiently effective, adjust the brake wire.

Important

Adjust to reduce the play in the brake lever as much as possible so that the brake does not drag when the lever is released.

1. Adjust the brake by tightening the brake wire adjustment bolt.

- If there is too much play in the brake lever, the braking power is reduced and the brake pedal feel is light.

- If there is too little play in the brake lever, the braking power is increased and the brake pedal feel is heavy.

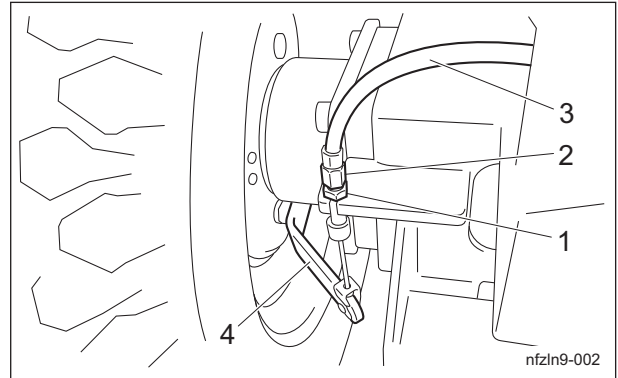

Adjustment of Brake_001

1	Lock nut
2	Adjustment bolt
3	Brake wire
4	Brake lever

2. Start the engine and drive to check the following.

- Make sure that heat is not generated in the brake area.
- Make sure that the left and right brakes are equally effective.

⚠ Caution

It may result in an unexpected accident if the left and right brakes are not equally effective.

3. If the left and right brakes are not equally effective, make fine adjustments with the adjustment bolt on the brake wire.

Break-In of Brakes

If the brake shoes or brake pads are worn, replace them with new ones.

Immediately after replacement, drive to break in the brakes if the effectiveness of the brakes is low.

While driving, lightly operate the brakes to break in the contact areas.

Adjusting the Neutral Position of the Piston Pump

Warning

When adjusting the neutral position, exercise care so that the hand does not get entangled in the rotating parts.

Caution

Make sure not to touch rotating tires.

Caution

When adjusting the neutral position, pay close attention to abrupt start of the machine. Place the jacks beneath the jack-up points, and then lift the machine until all the tires get off the ground.

If the machine moves forward or backward while the traveling pedals are released, they are not set to the neutral position.

Follow the steps below to make adjustments.

1. Stop the engine.
2. Remove the cotter pin and washer from the pedal end, and then disconnect the end of the push-pull cable.

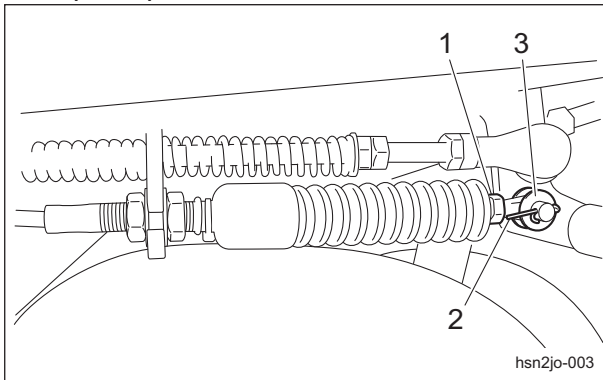

Adjusting the Neutral Position of the Piston Pump_001

1	Push-pull cable
2	Cotter pin
3	Washer

3. Place the jacks beneath the jack-up points, and then lift the machine off the ground. Use stable jack stands, and raise the machine until the tires lift off the ground. "Jack-up Points" (Page 5-5)
4. Start the engine, and rev it up to the maximum rpm.
5. Loosen the nut on the camshaft.

6. Slowly rotate the camshaft until the rear wheels stop, and then lock the camshaft with the nut at the stopped position.

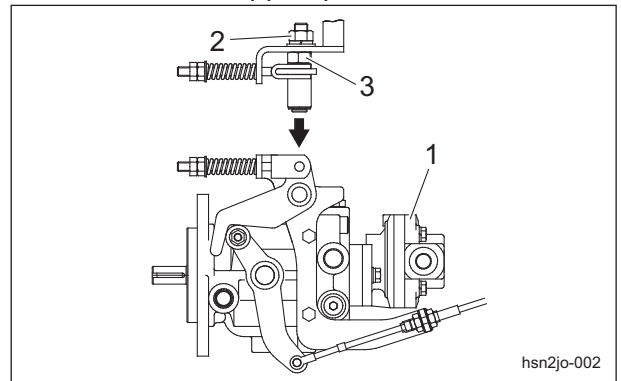

Adjusting the Neutral Position of the Piston Pump_002

1	Piston pump
2	Nut
3	Camshaft

7. Loosen the adjuster nuts.

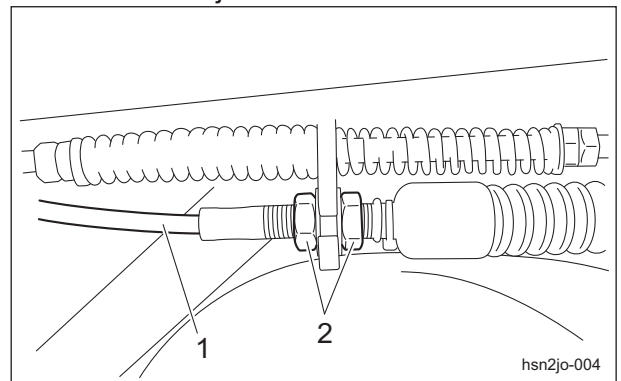

Adjusting the Neutral Position of the Piston Pump_003

1	Push-pull cable
2	Adjuster nuts

8. Adjust the nuts until the end of the push-pull cable of the pedal side attaches to the pedal mount, and then tighten the adjuster nuts.

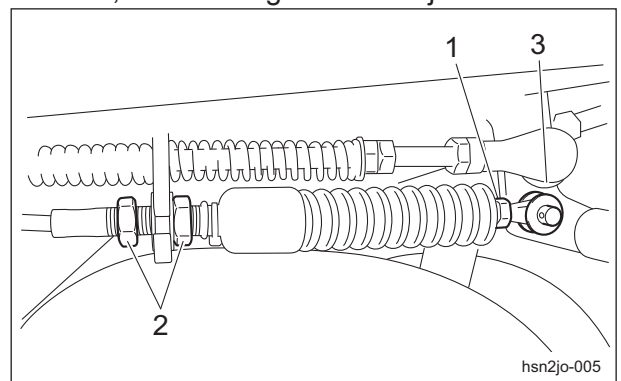

Adjusting the Neutral Position of the Piston Pump_004

Maintenance

1	Push-pull cable
2	Adjuster nuts
3	Pedal mount

9. Insert the push-pull cable, and then install the washer and cotter pin.

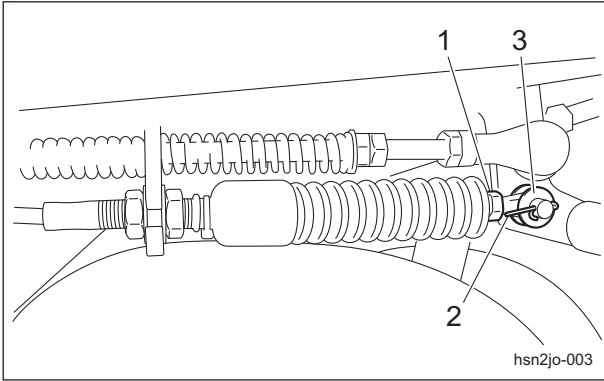

Adjusting the Neutral Position of the Piston Pump_005

1	Push-pull cable
2	Cotter pin
3	Washer

Adjustment of Front Apron

⚠ Caution

Be sure to stop the engine before adjusting the front apron.

Important

Check that the front apron and front apron adjusting plate are installed straight, with the left and right sides at the same height.

Important

Adjust the height of the front apron according to the core size and quantity.

1. Loosen the flange nut.

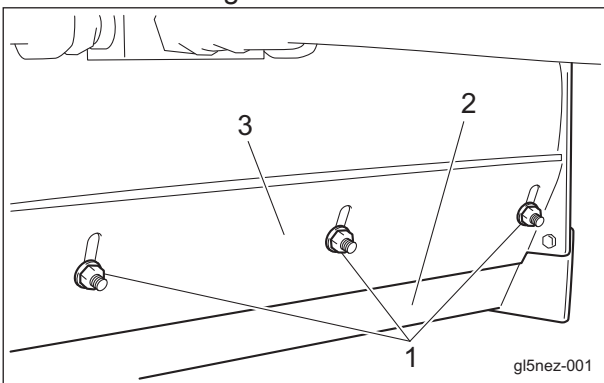

Adjustment of Front Apron_001

1	Flange nut
2	Front apron
3	Front apron adjusting plate

Important

Tighten the nut until 3 or 4 bolt threads are visible.

2. Adjust the front apron and front apron adjusting plate, and then tighten the flange nut.

[1] When to lower the apron

- Small cores
- Small quantity
- Cores fly out in front of the front apron.

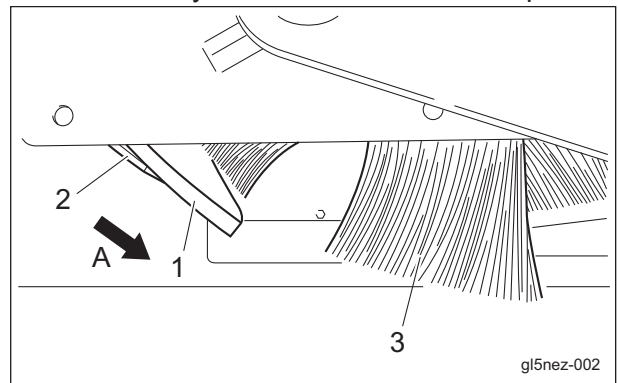

Adjustment of Front Apron_002

1	Front apron
2	Front apron adjusting plate
3	Brush
A	Lower

[2] When to raise the apron

- Large cores
- Large quantity
- Cores are pressed down by the apron.

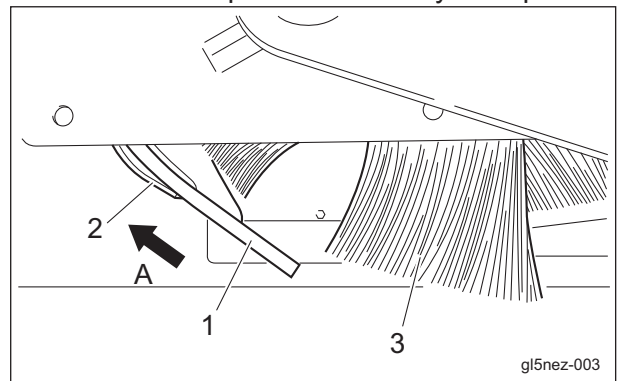

Adjustment of Front Apron_003

1	Front apron
2	Front apron adjusting plate
3	Brush
A	Raise

Adjustment of Brushes

Caution

For maintenance service, raise the empty bucket.

Important

If the brush operation height is inadequate, cores will not be properly collected.

Important

If the left and right sides of the brushes are at different heights, the cores will not be uniformly collected, and the brushes will wear unevenly.

If the rotary brush becomes too short, adjust the positions of the brush tips.

1. Move the machine to level ground.
2. Depress the locking pedal while firmly depressing the brake pedal to lock it.
3. Shift the bucket up/down lever to the "UP" position to raise the bucket.
4. Stop the engine.

Warning

To keep the position of raised bucket, be sure to lock it with the cylinder lock.

5. Lock the bucket with the cylinder lock.
6. Disengage the left and right slide latches.

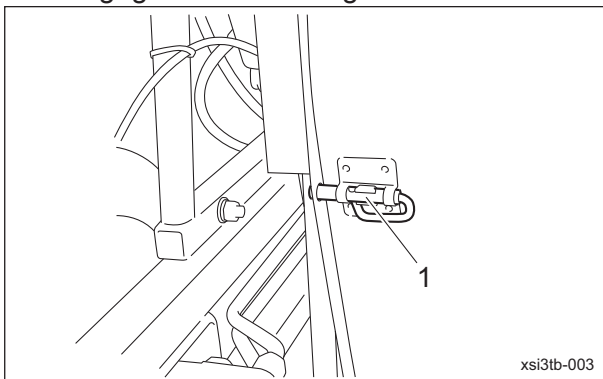

Adjustment of Brushes_001

1	Slide latch
---	-------------

7. Remove the brush cover.

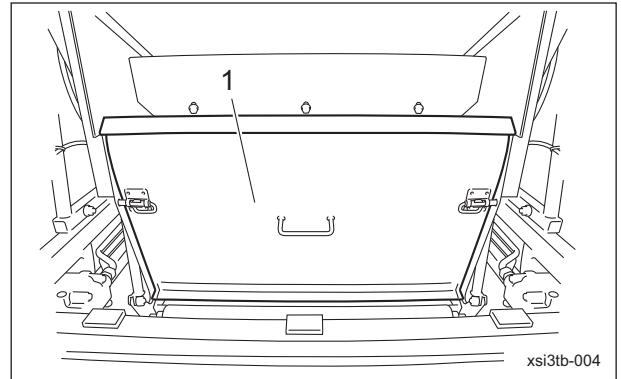

Adjustment of Brushes_002

1	Brush cover
---	-------------

8. Loosen the bolts securing the brush.

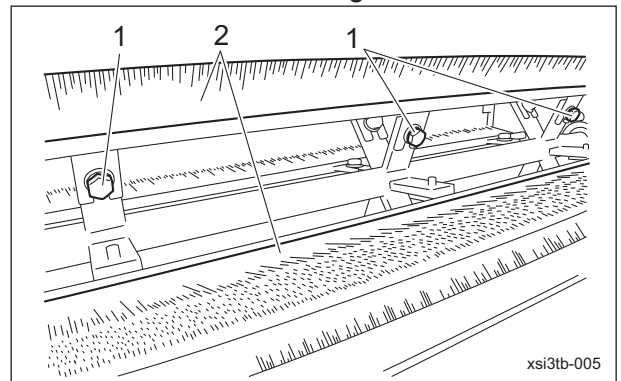

Adjustment of Brushes_003

1	Bolt
2	Brush

Maintenance

Important

Evenly install the brush.

- Adjust the brush so that there is a clearance of approximately 5.0 mm (0.20 in) between its tip and the brush frame, and then temporarily tighten the bolts.

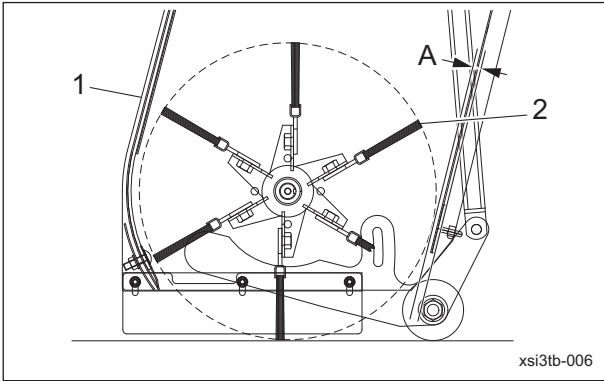

Adjustment of Brushes_004

1	Brush frame
2	Tip of rotary brush
A	5.0 mm (0.20 in)

- Slowly rotate the rotary brushes by hand, and then follow the same steps to adjust the remaining brushes and temporarily tighten the bolts.
- Slowly rotate the rotary brushes by hand, check the clearance again and tighten the bolts.
- After making adjustments and tightening the bolts, tighten all bolts firmly.
- Install the brush cover.
- Start the engine, rotate the brushes, and then check that there is no contact between or vibration in the brushes and brush frame.

Change of Brushes

Caution

During maintenance service, raise the empty bucket.

Important

If the brush operation height is inadequate, cores will not be properly collected.

Important

If the left and right sides of the brushes are at different heights, the cores will not be uniformly collected, and the brushes will wear unevenly.

Important

Replace all brushes. Otherwise the weight will become unbalanced and vibration may occur.

If the clearance between the rotary brush tips and the brush frame cannot be adjusted to approximately 5.0 mm (0.20 in) due to brush wear, replace the brushes.

- Move the machine to level ground.
- Depress the locking pedal while firmly depressing the brake pedal to lock it.
- Shift the bucket up/down lever to the "UP" position to raise the bucket.
- Stop the engine.

Warning

To keep the position of raised bucket, be sure to lock it with the cylinder lock.

- Lock the bucket with the cylinder lock.
- Disengage the left and right slide latches.

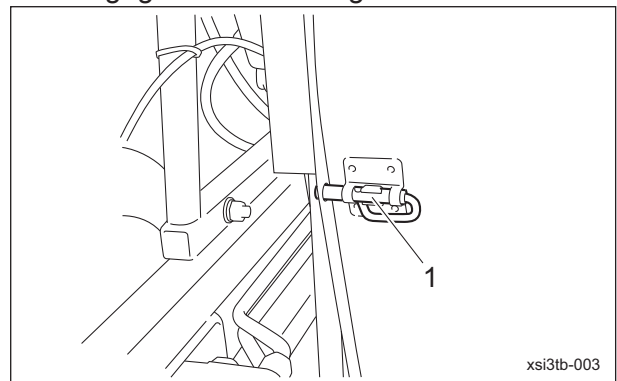

Change of Brushes_001

1	Slide latch
---	-------------

7. Remove the brush cover.

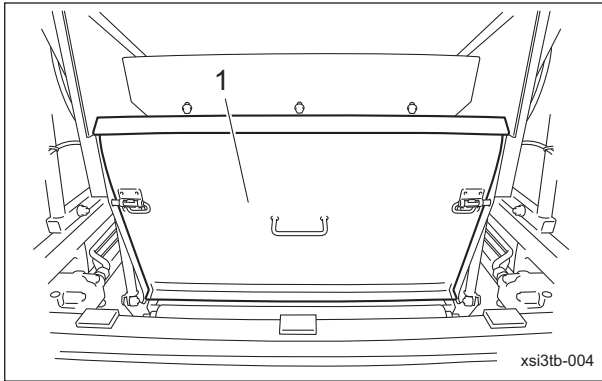

Change of Brushes_002

1	Brush cover
---	-------------

8. Remove the bolts securing the brush.

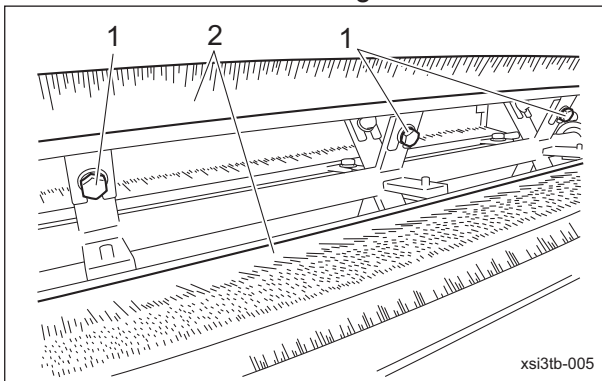

Change of Brushes_003

1	Bolt
2	Brush

9. Remove the rotary brush.

10. Install a new rotary brush.

Important

Evenly install the brush.

11. Adjust the brush so that there is a clearance of approximately 5.0 mm (0.20 in) between its tip and the brush frame, and then temporarily tighten the bolts.

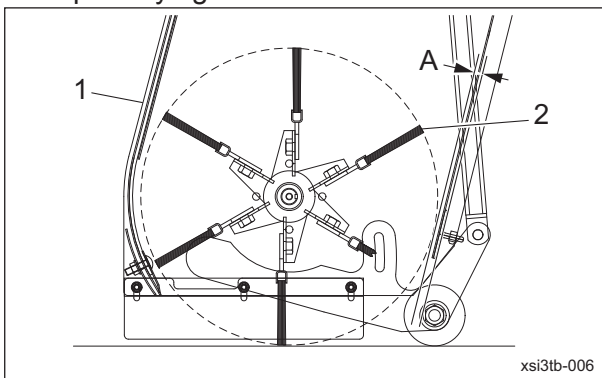

Change of Brushes_004

1	Brush frame
2	Tip of rotary brush
A	5.0 mm (0.20 in)

12. Slowly rotate the rotary brushes by hand, and then follow the same steps to adjust the remaining brushes and temporarily tighten the bolts.
13. Slowly rotate the rotary brushes by hand, check the clearance again and tighten the bolts.
14. After making adjustments and tightening the bolts, tighten all bolts firmly.
15. Install the brush cover.
16. Start the engine, rotate the brushes, and then check that there is no contact between or vibration in the brushes and brush frame.

Adjustment of Rotary Plates

Caution

For maintenance service, raise the empty bucket.

Important

Adjust all rotary plates properly. Otherwise vibration may occur, causing damage or an accident.

Important

If the gap between the rotary plates and brush frame is not appropriate, cores will not be properly collected.

1. Move the machine to level ground.
2. Depress the locking pedal while firmly depressing the brake pedal to lock it.
3. Shift the bucket up/down lever to the "UP" position to raise the bucket.
4. Stop the engine.

Warning

To keep the position of raised bucket, be sure to lock it with the cylinder lock.

5. Lock the bucket with the cylinder lock.

Maintenance

6. Disengage the left and right slide latches.

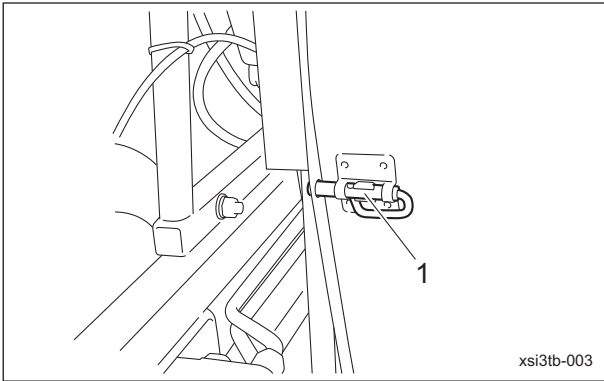

Adjustment of Rotary Plates_001

1	Slide latch
---	-------------

7. Remove the brush cover.

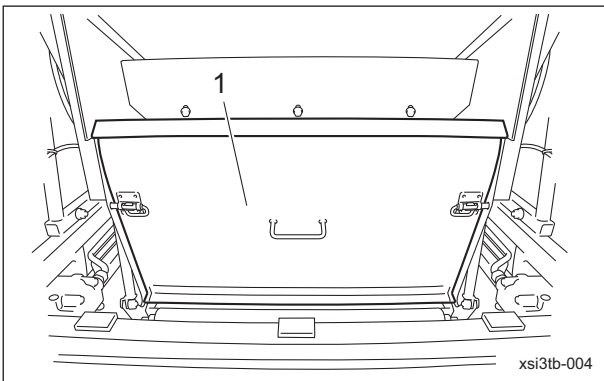

Adjustment of Rotary Plates_002

1	Brush cover
---	-------------

8. Loosen the bolts securing the rotary plate.

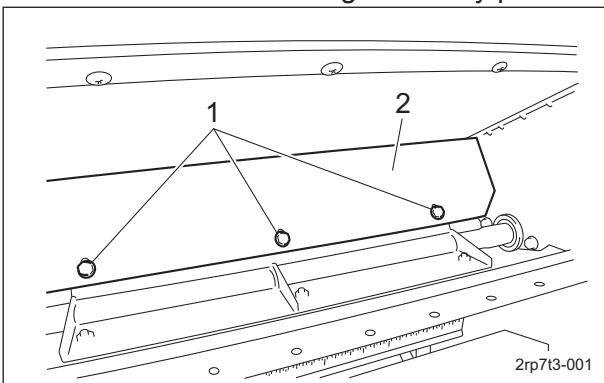

Adjustment of Rotary Plates_003

1	Bolt
2	Rotary plate

9. Adjust the rotary plate so that there is a clearance of approximately 5.0 mm (0.20 in) between it and the brush frame, and then temporarily tighten the bolts.

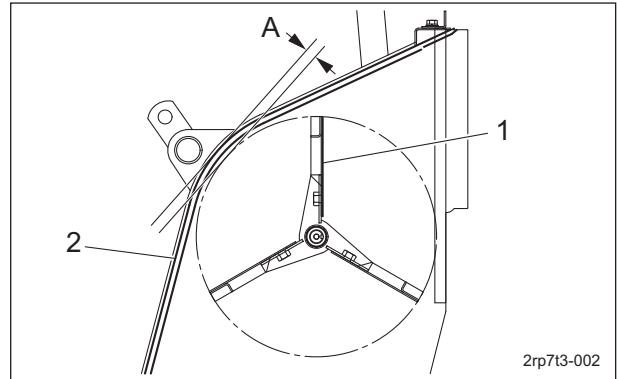

Adjustment of Rotary Plates_004

1	Rotary Plates
2	Brush frame
A	5.0 mm (0.20 in)

10. Slowly rotate the rotary plates by hand, and then follow the same steps to adjust the remaining rotary plates and temporarily tighten the bolts.
11. Slowly rotate the rotary plates by hand, check the clearance again and tighten the bolts.
12. After making adjustments and tightening the bolts, tighten all bolts firmly.
13. Install the brush cover.
14. Start the engine, rotate the rotary plates, and then check that there is no contact between or vibration in the rotary plates and brush frame.

Important

Evenly install the rotary plate.

Change of Rotary Plates

⚠ Caution

During maintenance service, raise the empty bucket.

Important

If the rotary plates are worn, cores will not be properly collected.

Important

Replace all rotary plates. Otherwise the weight will become unbalanced and vibration may occur.

If wear of the rotary plates exceeds 5.0 mm (0.20 in) or if they are deformed or cracked, replace the rotary plates.

1. Move the machine to level ground.
2. Depress the locking pedal while firmly depressing the brake pedal to lock it.
3. Shift the bucket up/down lever to the "UP" position to raise the bucket.
4. Stop the engine.

⚠ Warning

To keep the position of raised bucket, be sure to lock it with the cylinder lock.

5. Lock the bucket with the cylinder lock.
6. Disengage the left and right slide latches.

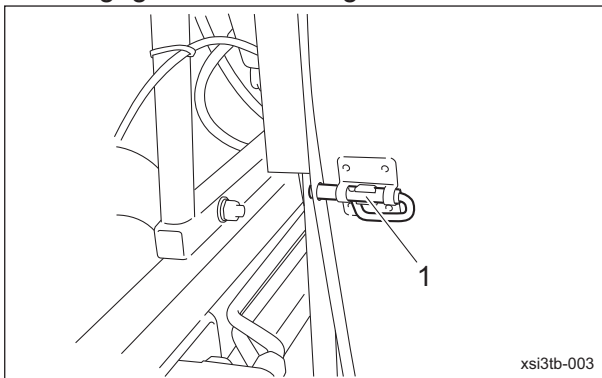

Change of Rotary Plates_001

1	Slide latch
---	-------------

7. Remove the brush cover.

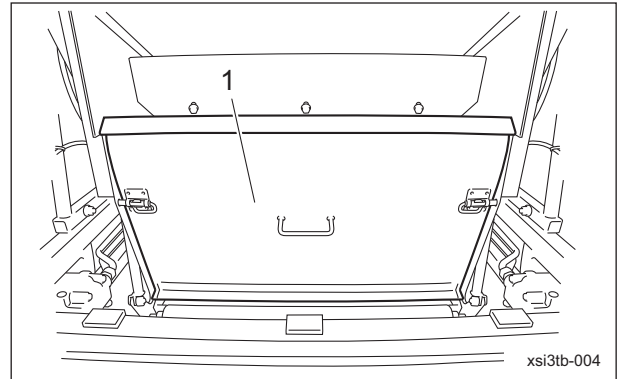

Change of Rotary Plates_002

1	Brush cover
---	-------------

8. Remove the bolts securing the rotary plate.

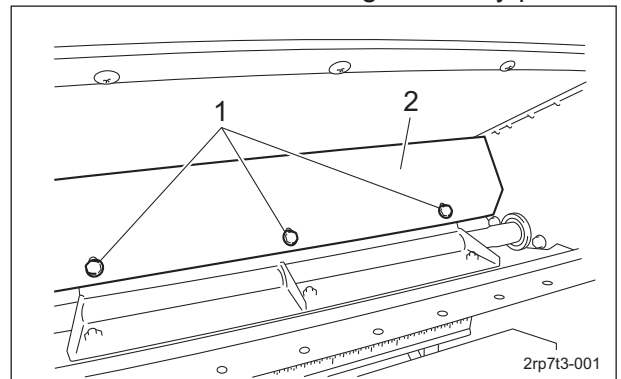

Change of Rotary Plates_003

1	Bolt
2	Rotary plate

9. Remove the rotary plate.
10. Install a new rotary plate.

Maintenance

Important

Evenly install the rotary plate.

- Adjust the rotary plate so that there is a clearance of approximately 5.0 mm (0.20 in) between it and the brush frame, and then temporarily tighten the bolts.

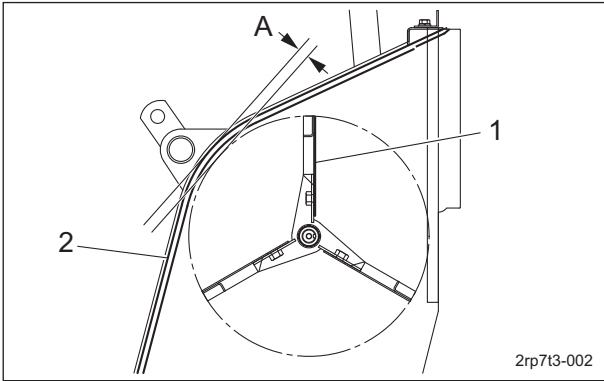

Change of Rotary Plates_004

1	Rotary Plates
2	Brush frame
A	5.0 mm (0.20 in)

- Slowly rotate the rotary plates by hand, and then follow the same steps to adjust the remaining rotary plates and temporarily tighten the bolts.
- Slowly rotate the rotary plates by hand, check the clearance again and tighten the bolts.
- After making adjustments and tightening the bolts, tighten all bolts firmly.
- Install the brush cover.
- Start the engine, rotate the rotary plates, and then check that there is no contact between or vibration in the rotary plates and brush frame.

Change of Hydraulic Oil

Caution

Be careful with hot oil, which could cause burns if it contacts your skin.

Important

When you change the hydraulic oil, be sure to drain it into a bowl and discard it in accordance with local laws and regulations.

Important

If the oil emulsifies or if it becomes even slightly less transparent, change the oil immediately.

Important

Use Shell Tellus S2M46 (or equivalent) as hydraulic oil. In case of an equivalent, consult Characteristics of Hydraulic Oil and use hydraulic oil whose characteristics are superior to those of the specific hydraulic oil. Especially regarding kinematic viscosity and viscosity index, use of hydraulic oil whose figures are less than those of the specified hydraulic oil will cause a malfunction in the hydraulic circuit.

Note:

Characteristics of Hydraulic Oil

Specified Hydraulic Oil		Shell Tellus S2M46
ISO Viscosity Grade		ISO VG46
Density	15 °C (59 °F)	0.873 g/cm ³ (0.0315 lb/in ³)
API Gravity		30.6
Flash Point (Open Cup)		230 °C (446 °F)
Pour Point		-30 °C (-22 °F)
Kinematic	40 °C (104 °F)	46 mm ² /s (46 cSt)
Viscosity	100 °C (212 °F)	7 mm ² /s (7 cSt)
Viscosity Index		109

- Follow the steps below to remove the old oil.
 - Start and run the engine to warm up the oil.
 - On a level surface, lower the brush frame and the bucket, and then stop the engine.
 - Remove the drain plug of the hydraulic tank, and then drain the old oil into a container.

[4] Wind new sealing tape on the drain plug, and then attach it to the hydraulic tank.

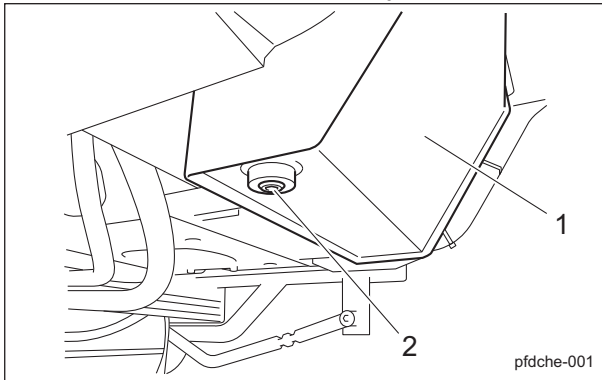

Change of Hydraulic Oil_001

1	Hydraulic tank
2	Drain plug

- Open the tank cap, and then pour new oil from the fill port until the oil level reaches the middle of the oil gauge on the hydraulic tank. The hydraulic tank capacity is approximately 17.0 dm³ (17.0 L).

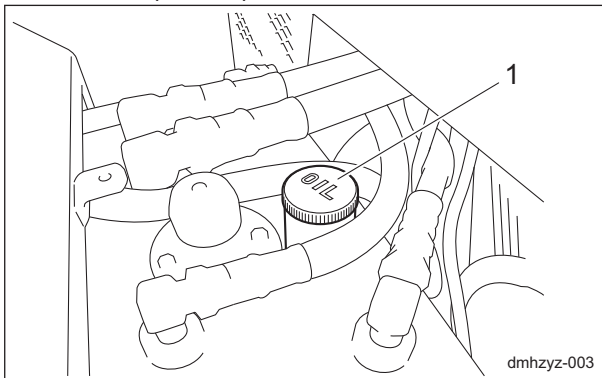

Change of Hydraulic Oil_002

1	Tank cap
---	----------

- Tighten the tank cap securely.
- Start the engine, raise and lower the brush frame and the bucket, and then drive the machine forward and in reverse repeatedly several times.
- On a level surface, lower the brush frame and the bucket and maintain that position, and then check to see if the oil level is at the middle of the oil gauge. If necessary, supply oil.
- Check underneath the machine for oil leakage.

Change of Hydraulic Oil Filter

Change of Hydraulic Oil Line Filter

Caution

Be careful with hot oil, which could cause burns if it contacts your skin.

Important

When replacing the hydraulic oil filter, be sure to drain the oil into a container and discard it in accordance with local laws and regulations.

Important

If the hydraulic oil emulsifies or if it becomes even slightly less transparent, change the oil immediately.

Important

Use Shell Tellus S2M46 (or equivalent) as hydraulic oil.

- Remove the cover on the right side of the seat.
- On a level surface, lower the brush frame and the bucket, and then stop the engine.
- Loosen the filter case and remove it.

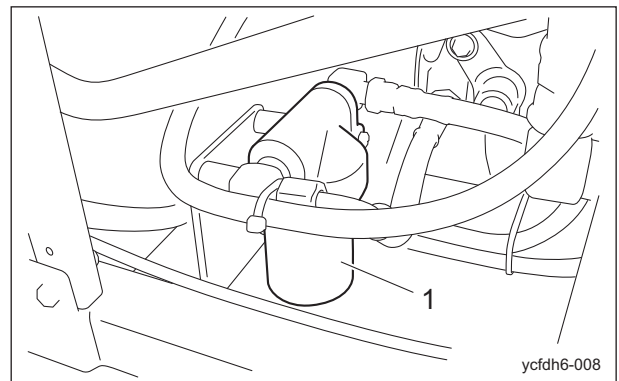

Change of Hydraulic Oil Line Filter_001

1	Filter case
---	-------------

Maintenance

4. Remove the old filter cartridge.

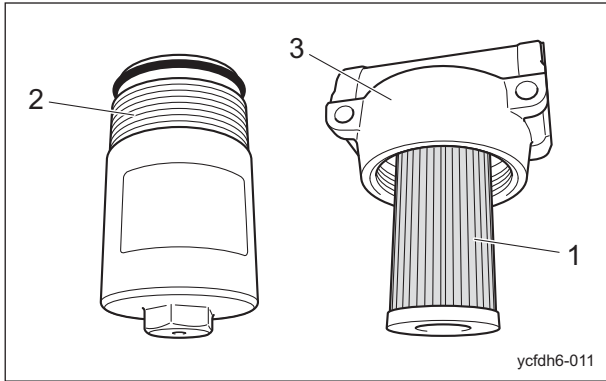

Change of Hydraulic Oil Line Filter_002

1	Filter cartridge
2	Filter case
3	Body

5. Lightly coat the O-ring of the new filter cartridge with hydraulic oil, and then install the cartridge.

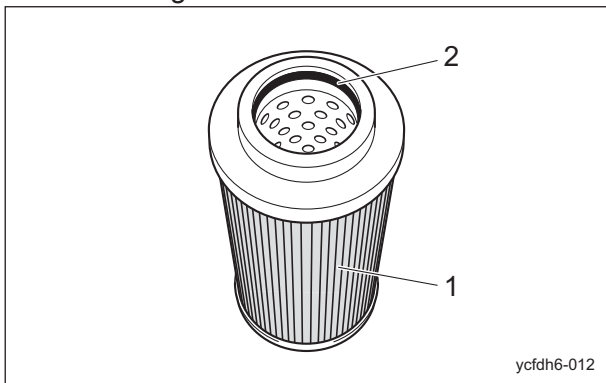

Change of Hydraulic Oil Line Filter_003

1	Filter cartridge
2	O-ring

6. Clean the inside of the filter case.

7. Make sure that there is no damage to the O-ring of the filter case, and then lightly coat the O-ring with hydraulic oil.

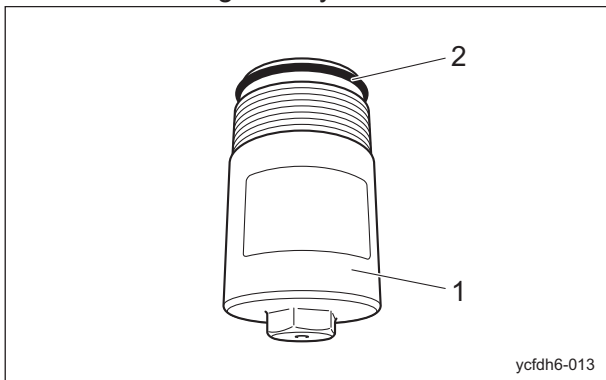

Change of Hydraulic Oil Line Filter_004

1	Filter case
2	O-ring

8. Install the filter case onto the body, firmly hand-tighten it, and then tighten it to 25 to 35 N·m (254.93 - 356.90 kgf-cm).

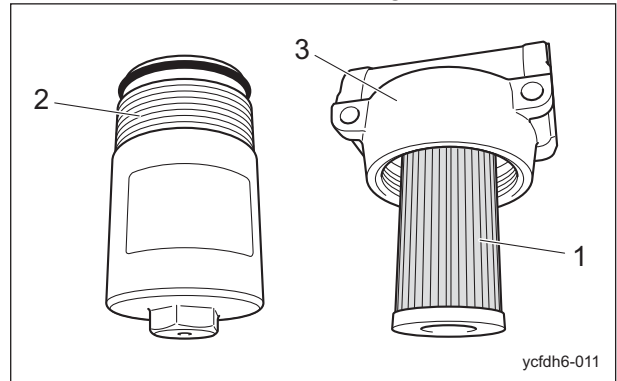

Change of Hydraulic Oil Line Filter_005

1	Filter cartridge
2	Filter case
3	Body

9. Supply hydraulic oil until it reaches the specified level.

"Hydraulic Oil Supply" (Page 4-4)

10. Start the engine and stop it after hydraulic oil warmed.

11. Check underneath the machine for hydraulic oil leakage.

12. Install the cover on the right side of the seat.

Change of Hydraulic Suction Filter

Caution

Be careful with hot oil, which could cause burns if it contacts your skin.

Important

When replacing the hydraulic oil filter, be sure to drain the oil into a container and discard it in accordance with local laws and regulations.

Important

If the hydraulic oil emulsifies or if it becomes even slightly less transparent, change the oil immediately.

Important

Use Shell Tellus S2M46 (or equivalent) as hydraulic oil.

1. Remove the cover on the right side of the seat.
2. On a level surface, lower the brush frame and the bucket, and then stop the engine.
3. Remove the old filter cartridge.
4. Lightly coat the packing of the new filter cartridge with hydraulic oil, and then install the cartridge.
5. Firmly tighten the filter cartridge by hand so that the packing contacts the mounting surface.
Then, tighten it an additional 1/2 turn.

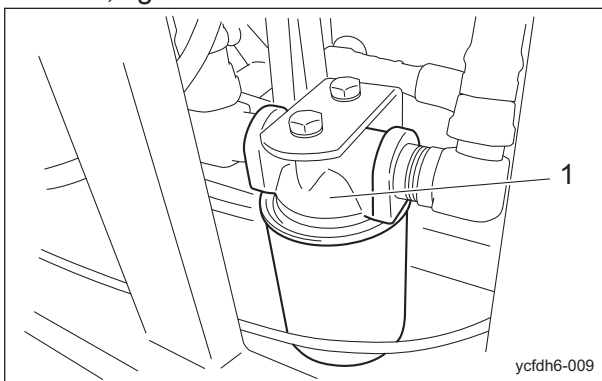

Change of Hydraulic Suction Filter_001

1	Cartridge filter
---	------------------

6. Supply hydraulic oil until it reaches the specified level.
"Hydraulic Oil Supply" (Page 4-4)

7. Start the engine, and then after the hydraulic oil has warmed up, stop the engine.
8. Check underneath the machine for hydraulic oil leakage.
9. Install the cover on the right side of the seat.

Change of Air Cleaner

A contaminated air cleaner element may cause malfunction of the engine.

To maximize the life of the engine, replace the air cleaner element at the appropriate times.

1. The timing for replacing the air cleaner element is described below.
 - [1] Replace the air cleaner element in accordance with the Maintenance Schedule.
 - [2] If it is significantly contaminated, replace it, even if the hours of operation do not exceed the specified time.
2. Replace the air cleaner element by following the same steps as for cleaning the air cleaner.
"Cleaning of Air Cleaner" (Page 4-5)

Maintenance

Change of Engine Oil

Caution

Be careful with hot oil, which could cause burns if it contacts your skin.

Important

When you change the engine oil, be sure to drain it into a bowl and discard it in accordance with local laws and regulations.

Important

Be sure to use engine oil that is classified as API Service Grade SF or higher, with an SAE Viscosity that is appropriate for the operating environment (ambient temperature).

Important

Securely tighten the oil level gauge and oil filler cap.

Change the engine oil more frequently, if the engine oil is contaminated, and especially if you use the machine in dusty areas or operate the engine at high loads or in high temperatures.

1. Move the machine onto a level surface, stop the engine, remove the drain plug while the engine oil is warm, and then drain the oil into a bowl.
2. Wind new sealing tape on the drain plug, and then re-place it in the engine..

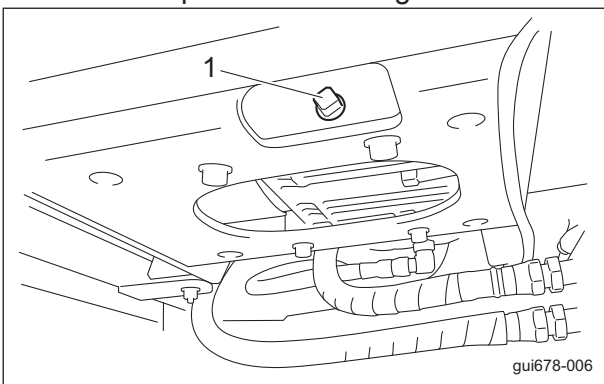

Change of Engine Oil_001

1	Drain plug
---	------------

3. Open the underseat cover.

4. Remove the oil filler cap, and then supply new engine oil through the oil filling port until the oil reaches a level in between the upper and lower limit lines on the oil level gauge.
5. Supply 1.0 dm³ (1.0 L) of engine oil, remove the oil level gauge, and then insert the oil level gauge all the way to check the oil level.
6. After checking the level with the oil level gauge, supply more engine oil if it is insufficient.
The engine oil quantity (including the oil filter) is approximately 1.6 dm³ (1.6 L).
7. Replace the oil filler cap.

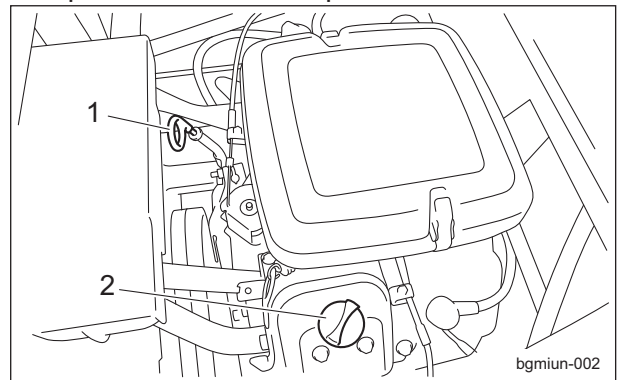

Change of Engine Oil_002

1	Oil level gauge
2	Oil filler cap

8. It will take a while for the supplied engine oil to descend into the oil pan.
Check the oil level again 10 to 20 minutes after supplying the oil.
9. Close the underseat cover.
10. Check underneath the machine for oil leakage.

Change of Engine Oil Filter

Caution

Be careful with hot oil, which could cause burns if it contacts your skin.

Important

When replacing the engine oil filter, be sure to drain the engine oil into a container and discard it in accordance with local laws and regulations.

Important

Be sure to use engine oil that is classified as API Service Grade SF or higher, with an SAE Viscosity that is appropriate for the operating environment (ambient temperature).

Important

Securely tighten the oil level gauge and oil filler cap.

1. With the filter wrench, remove the old filter cartridge.

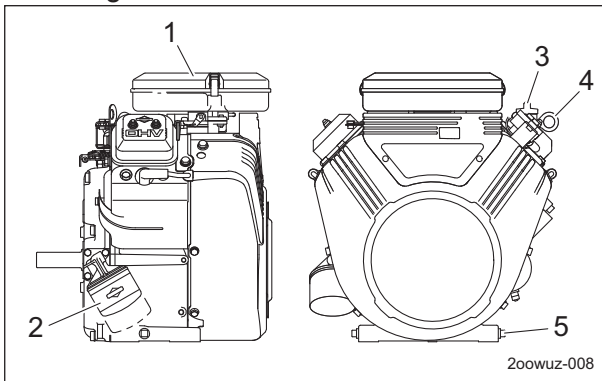

Change of Engine Oil Filter_001

1	Engine
2	Filter cartridge
3	Oil filler cap
4	Oil level gauge
5	Drain plug

2. Lightly coat the packing of the new filter cartridge with engine oil.
3. Hand-tighten the filter cartridge until the packing contacts the mounting surface, and then hand-tighten additional 1/2 turn.

4. Supply engine oil until it reaches the specified level.
"Supply of Engine Oil" (Page 4-9)
5. Start the engine, and then stop it after 10 to 20 minutes.
6. Make sure that there is no oil leakage at the sealing surface of the filter cartridge.
7. Check the engine oil level.
If it is low, supply engine oil until it reaches the specified level.
8. Check underneath the machine for oil leakage.

Change of Fuel Filter

Important

While installing the fuel filter, prevent contamination with dirt or dust. The fuel contaminated with dirt or dust will cause engine failure.

- Since the fuel filter is a cartridge, it cannot be disassembled or cleaned. If dust or dirt accumulates in the fuel filter, the fuel flow will become insufficient. Replace the fuel filter at the appropriate times.
1. Remove the old fuel filter.
 2. Install a new fuel filter with the arrow marked on it pointing toward the engine.

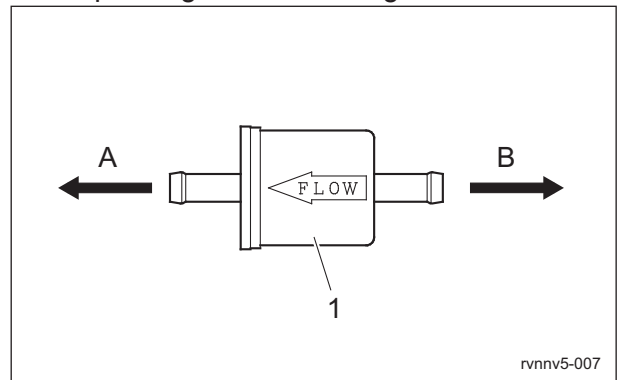

Change of Fuel Filter_001

1	Fuel filter
A	Engine
B	Fuel cock

Maintenance

Change of Fuse

Important

When performing maintenance on the electrical system, be sure to remove the negative battery wire.

Important

If a fuse blows, a short may have occurred within the electrical circuit. Check for the cause, such as faulty terminal connections, damaged wiring or terminals, or incorrect wiring.

Important

For fuse replacement, clean the fuse mounting area with use of compressed air before mounting the fuse.

Fuses

Fuses are located in the lower right corner behind the front cover and consist of the main harness fuse for the entire circuit. It is a mini blade fuse 20 A.

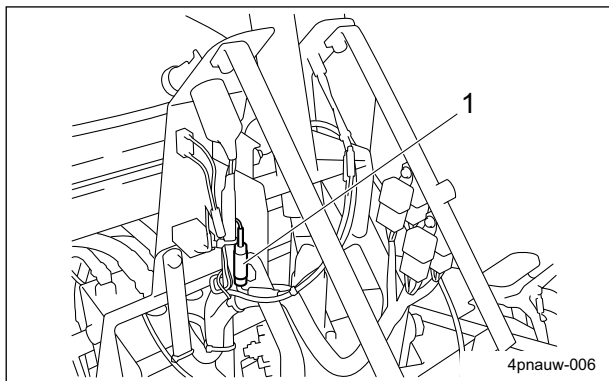

Fuses_001

1	Main harness fuse
---	-------------------

BARONESS[®]
Quality on Demand

 **KYOEISHA CO., LTD.**
Head Office 1-26, Miyuki-cho, Toyokawa-city, Tel :+81-533-84-1390
Aichi-pref, 442-8530 JAPAN Fax:+81-533-84-1220