

LM315GC

Riding Greens Mower (Diesel Model)

Owner's Operating Manual

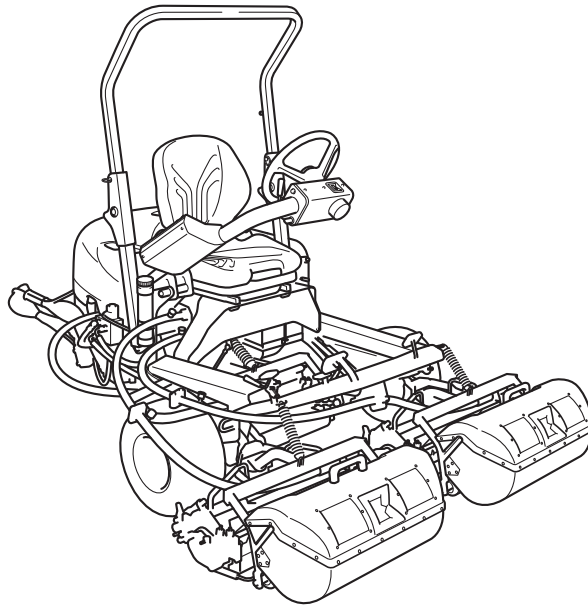

Serial No. LM315GC : 31318-

"Required reading"
Read this manual before using the machine.

BARONESS[®]
Quality on Demand

Original Instructions Ver.3.5

Regulations

California Proposition 65

(For California, USA)

WARNING:

Operating, servicing and maintaining a passenger vehicle or off-road vehicle can expose you to chemicals including engine exhaust, carbon monoxide, phthalates, and lead, which are known to the State of California to cause cancer and birth defects or other reproductive harm. To minimize exposure, avoid breathing exhaust, do not idle the engine except as necessary, service your vehicle in a well-ventilated area and wear gloves or wash your hands frequently when servicing your vehicle. For more information go to www.P65Warnings.ca.gov/passenger-vehicle.

318yi8-005

California Proposition 65_001

California Spark Arrester

(For California, USA)

Warning

Operation of this equipment may create sparks that can start fires around dry vegetation.

A spark arrester may be required.

The operator should contact local fire agencies for laws or regulations relating to fire prevention requirements.

The engine of this machine is not equipped with a spark arrester.

In some areas there are local, state, or federal regulations requiring that a spark arrester be used on the engine of this machine.

The recommended spark arrester for this machine is Part No.49025N Spark Arrester made by Nelson Global Products.

Thank you for purchasing the Baroness product.
This manual describes the proper handling,
adjustment, and inspection of your product.
We hope you will use the product safely, and take
advantage of its best performance.

Keeping The Owner's Operating Manual

Keep this manual in the box on the right side of
the seat.

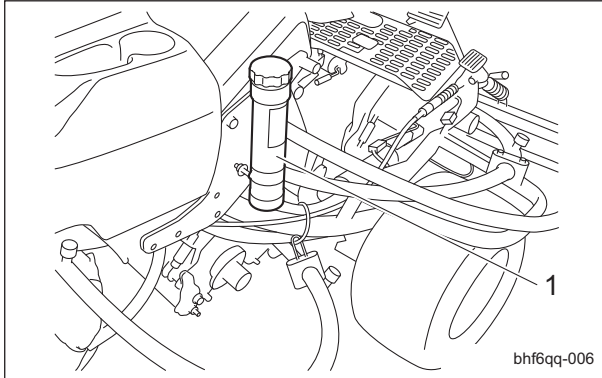

Keeping The Owner's Operating Manual_001

1	Box
---	-----

Introduction

Read this manual carefully to ensure that you thoroughly understand how to properly operate and maintain the product, and to avoid causing injury to yourself or others.

The operator is responsible for operating the product properly and safely.

Maintenance should only be performed by a certified specialist.

If you have any questions concerning maintenance or genuine parts, please contact a Baroness dealer or Kyoisha.

When making inquiries about the product, please specify the product's model designation and serial number.

When loaning or transferring the product, please also provide this manual together with the product.

Kyoisha Co., Ltd.

Warning Symbols

This manual uses the following warning symbols for handling precautions that are important for your safety.



696cq5-001

Warning symbol

This symbol indicates the articles regarding “Danger,” “Warning,” or “Caution.”

Those articles describe important safety precautions and so read them carefully to understand completely before operating the machine.

Failure to adequately follow these safety precautions may cause an accident.

Danger

This symbol indicates that serious injury or death will occur if the warning is ignored.

Warning

This symbol indicates that serious injury or death may occur if the warning is ignored.

Caution

This symbol indicates that injury or damage to property may occur if the warning is ignored.

Important

This symbol indicates precautions on the mechanism of the machine.

Precautionary Statement

Caution

The information described in this manual is subject to change for improvement without prior notice.

When replacing parts, be sure to use genuine Baroness parts or parts designated by Kyoeshia.

Note that the Baroness product warranty may not apply to defects caused by the use of parts from other companies.

Prior to use, carefully read the following manuals to thoroughly understand the contents for safe and correct operation.

- Baroness Owner's Operating Manual
- The Engine's Owner's Manual
- The Battery's Owner's Manual

Purpose

For greens/for tees: This product is intended for cutting turf grass at golf courses.

For fields: This product is intended for cutting turf grass on soccer and baseball fields.

Do not use this product in any other way than its intended purpose, and do not modify this product.

Operating this product for other purposes and modifying it may be very dangerous and may cause damage to the product.

In addition, this product is not authorized for operation as a special motor vehicle. Do not operate it on public roads.

LM315GC

Introduction

Safety	Page 1-1
Safe Operating Practices	Page 1-2
Disposal	Page 2-1
Recycle and Waste Disposal	Page 2-2
Product Overview	Page 3-1
Specifications	Page 3-2
Names of Each Section	Page 3-4
Regulation Decals	Page 3-4
Safety Signs and Instruction Signs	Page 3-7
Handling Instructions	Page 4-1
Inspections	Page 4-3
Tightening Torques	Page 4-13
Adjustment before Work	Page 4-17
Procedure to Start/Stop Engine	Page 4-24
Operation Method	Page 4-26
Instruments	Page 4-37
Travel of Machine	Page 4-39
Cutting Work	Page 4-40
Transporting	Page 4-42
Storage	Page 4-42
Maintenance	Page 5-1
Maintenance Precautions	Page 5-2
Maintenance Schedule	Page 5-2
Jacking Up The Machine	Page 5-9
Greasing	Page 5-10
Lubrication	Page 5-14
Maintenance Work	Page 5-15

LM315GC

Contents

Safe Operating Practices Page 1-2

Training Page 1-2

Preparation Page 1-2

Operation Page 1-3

Maintenance and Storage Page 1-4



Safety

Failure to adequately follow these safety precautions may cause an accident resulting in injury or death.

Danger

This product is designed to ensure safe operation and has been tested and inspected thoroughly before shipment from the factory. The product is equipped with safety devices to prevent accidents.

However, whether the product demonstrates its original performance level depends on the manner in which it is operated and handled, as well as the manner in which it is managed on a daily basis.

Inappropriate use or management of the product may result in injury or death.

Observe the following safety instructions to ensure safe operation.

Safe Operating Practices

Training

1. Read this manual and other training material carefully. Be familiar with the controls, safety signs, and the proper use of the equipment.
2. If the operator or mechanic can not read English it is the owner's responsibility to explain this manual to them.
3. All operators and mechanics should seek and obtain professional and practical instruction.
The owner is responsible for training the users.
Such instruction should emphasize.
 - [1] The need for care and concentration when working with ride-on machines.
 - [2] Control of a ride-on machine sliding on a slope will not be regained by the application of the brake.
The main reasons for loss of control are
 - Insufficient wheel grip
 - Being driven too fast
 - Inadequate braking
 - The type of machine is unsuitable for its task
 - Lack of awareness of the effect of ground conditions, especially slopes
 - Incorrect hitching and load distribution

4. Never allow children or people unfamiliar with these instructions to use or service the machine.
Local regulations may restrict the age of the operator.
5. The owner/user can prevent and is responsible for accidents or injuries occurring to themselves, other people, or property.
6. Keep in mind that the owner, operator, and mechanic are responsible for accidents or hazards occurring to other people or their property.
7. The ROPS is an integral and effective safety device.
Do not remove or alter the ROPS.
8. Replace a damaged ROPS.
Do not repair or alter.
9. You can find additional safety information where needed throughout this manual.
10. Determine the left and right sides of the machine from the normal operating position.

Preparation

1. Evaluate the terrain to determine what accessories and attachments are needed to properly and safely perform the job. Only use accessories and attachments approved by the manufacturer.
2. While operating, always wear substantial footwear, long trousers, hard hat, safety glasses, and ear protection. Long hair, loose clothing, or jewelry may get tangled in moving parts. Do not operate the equipment when barefoot or wearing open sandals.
3. Inspect the area where the equipment is to be used and remove all objects such as rocks, toys and wire which can be thrown by the machine.
4. Keep children out of the operating area and under the watchful care of a responsible adult other than the operator.
5. Exercise care in the handling of fuel.

Warning

Warning-Fuel is highly flammable. Take the following precautions.

- [1] Store fuel in containers specifically designed for this purpose.

- [2] Add fuel before starting the engine. Never remove the cap of the fuel tank or add fuel while the engine is running or when the engine is hot.
- [3] Refuel outdoors only and do not smoke while refueling.
- [4] If fuel is spilled, do not attempt to start the engine but move the machine away from the area of spillage and avoid creating any source of ignition until petrol vapours have dissipated.
- [5] Replace all fuel tanks and container caps securely.
6. Check that operator's presence controls, safety switches and shields are attached and functioning properly. Do not operate unless they are functioning properly.
7. If the brake operation is faulty or the parking brake lever has noticeable play, be sure to adjust or repair them before operating the machine.
8. Replace faulty mufflers.
9. On multi-cylinder/multi-reel machines take care as rotating one cylinder/reel can cause other cylinder/reels to rotate.
- [5] Never operate across the face of the slope, unless the machine is designed for this purpose.
- [6] Never drive the machine on a slope with an angle of gradient that is greater than that specified or in a place where there is a danger of the machine slipping.
5. Use extra care while operating machine with a grass catcher or other attachments. They can affect the stability of the machine.
6. Never operate the machine with damaged guards, shields, or without safety protective devices in place. Be sure all interlocks are attached, adjusted and functioning properly.
7. Do not change the engine governor settings or overspeed the engine. Operating the engine at excessive speed may increase the hazard of personal injury.
8. Do the following before leaving the operator`s position.
 - [1] Stop on level ground.
 - [2] Disengage the power take-off and lower the attachments.
 - [3] Change into neutral and set the parking brake.
 - [4] Stop the engine and remove the key.

Operation

1. Do not operate the engine in a confined space where dangerous carbon monoxide fumes can collect.
2. Only operate in good light, keeping away from holes and hidden hazards.
3. Before attempting to start the engine, disengage all attachments, shift into neutral, and engage the parking brake. Only start engine from the operator`s position. Use seat belts if provided.
4. Remember there is no such thing as a safe slope. Travel on grass slopes requires particular care. To guard against overturning:
 - [1] Do not stop or start suddenly when going up or downhill.
 - [2] Engage clutch slowly, always keep machine in gear, especially when traveling downhill.
 - [3] Machine speeds should be kept low on slopes and during tight turns.
 - [4] Stay alert for humps and hollows and other hidden hazards.
9. Disengage the drive to attachments, stop the engine, and remove the ignition key in the following conditions.
 - [1] Before refueling.
 - [2] Before removing the grass catcher/ catchers.
 - [3] Before making height adjustment unless adjustment can be made from the operator's position.
 - [4] Before cleaning blockages.
 - [5] Before checking, cleaning, or working the machine.
 - [6] After striking a foreign object or if an abnormal vibration occurs. Inspect the machine for damage and make repairs before restarting and operating the equipment.
10. Keep hands and feet away from the cutting units and the rotating parts.
11. Do not mow in reverse unless absolutely necessary. Always look down and behind before and while backing.
12. Do not carry passengers.

Safety

13. Never operate while people, especially children, or pets are nearby.
14. Slow down and use caution when making turns and crossing roads and sidewalks.
15. Stop the blades rotating before crossing surfaces other than grass.
16. Disengage drive to attachments when transporting or not in use.
17. When using any attachments, never direct discharge of material toward bystanders nor allow anyone near the machine while in operation.
18. Do not operate the machine under the influence of alcohol or drugs.
19. Take care when loading or unloading the machine into a trailer or a truck. Load or unload the machine in a flat and safe place. Before loading or unloading, set the parking brake on the truck or trailer, stop the engine, and chock the wheels.
When transporting the machine on a truck or a trailer, set the parking brake, stop the engine, and fasten the machine to the truck with a rope or other suitable restraining device that has sufficient strength.
When using a loading ramp, select one with sufficient strength, length, and width and that will not cause the machine to slip.
20. Close the fuel valve before transporting the machine.
21. Use care when approaching blind corners, shrubs, trees, or other objects that may obscure vision.
22. Do not take your eyes off the road ahead. Do not operate the machine with no hands.
23. Reduce the throttle setting during engine run-out and, if the engine is provided with a shut-off valve, turn the fuel off at the conclusion of operation.
24. Do not operate the machine when there is the risk of lightning.
25. Keep a folding ROPS in the raised and locked position and use the seat belt when operating the machine.
26. Lower a folding ROPS temporarily only when absolutely necessary.
Do not wear the seat belt when folded down. There is no rollover protection when a folding ROPS is in the down position.

Maintenance and Storage

1. Disengage drives on level ground, lower the attachments, set parking brake, stop engine and remove key from ignition. Wait for all movement to stop before adjusting, cleaning or repairing.
2. When machine is to be parked, stored, or left unattended, lower the cutting units unless a positive mechanical lock is provided.
3. To reduce the fire hazard, keep the engine, silencer/muffler, battery compartment fuel storage area, cutting unit and drives free of grass, leaves, or excessive grease. Clean up oil or fuel spillage.
4. Allow the engine to cool before storing in any enclosure.
5. Only cover the machine with a sheet after hot parts have sufficiently cooled down.
6. Never store the equipment with fuel in the tank inside a building where fumes may reach an open flame or spark.
7. If the engine is provided with a shut-off valve, shut off valve while storing or transporting.
8. Do not store fuel near flames.
9. Never allow untrained personnel to service machine.
10. Allow the engine/muffler to cool before checking/maintenance.
11. Appropriately manage and correctly use the tools necessary for servicing or adjusting the machine.
12. Use jack stands to support components when required.
13. Carefully release pressure from components with stored energy.
14. Be sure to depressurize the hydraulic system before performing maintenance operations on it such as removing hydraulic equipment.
15. Check whether line connectors in the hydraulic system are properly tightened. Before applying hydraulic pressure, check the connections of the hydraulic pressure lines and the condition of the hoses.

16. When checking the hydraulic circuit for pinhole leaks or oil leakage from nozzles, do not use your hands. Use items such as paper or corrugated cardboard to find leakage points. Be extremely careful with high-pressure oil as it may pierce your skin, resulting in an injury.
If fluid is injected into the skin it must be surgically removed within a few hours by a doctor familiar with this form of injury or gangrene may result.
17. Disconnect battery before making any repairs. Disconnect the negative terminal first and the positive last. Reconnect positive first and negative last.
18. Make sure that parts such as wires are not touching each other and that their covers have not come off.
19. Use care when checking the cylinders/reels and bed knives.
 - [1] Wear gloves and use caution when servicing them.
 - [2] Be careful during adjustment of the machine to prevent entrapment of the fingers between moving blades and fixed parts of the machine.
20. On multi-cylinder/multi-reel machines take care as rotating one cylinder/reel can cause other cylinder/reels to rotate.
21. Keep hands and feet away from moving parts. If possible, do not make adjustments with the engine running.
22. Charge batteries in an open well ventilated area, away from spark and flames. Unplug charger before connecting or disconnecting from battery. Wear protective clothing and use insulated tools.
23. Keep all parts in good working condition and all hardware tightened. Replace all worn or damaged decals.
24. Keep all nuts, bolts and screws tight to be sure the equipment is in safe working condition.
25. Check the grass catcher frequently for wear or deterioration.
26. If the fuel tank has to be drained, do this outdoors.
27. Swallowing engine coolant can cause injury or death; keep out of reach from children and pets.

Recycle and Waste Disposal Page 2-2

About RecyclePage 2-2

About Waste Disposal Page 2-2

Disposal

Recycle and Waste Disposal

About Recycle

Recycling battery etc. is recommended for environmental conservation and economical use of resources.

It may be required by local laws.

About Waste Disposal

Make sure that waste generated when servicing or repairing the machine is disposed of in accordance with local regulations. (e.g. waste oil, antifreeze, rubber products, and wires etc.)

Specifications Page 3-2

SpecificationsPage 3-2

Sound Pressure Level Page 3-3

Sound Power Level Page 3-3

Vibration LevelPage 3-3

Carbon Dioxide (CO₂) Emissions
MeasurementPage 3-4**Names of Each Section Page 3-4****Regulation DecalsPage 3-4**

Positions of Regulation Decals Page 3-4

Description of Regulation Decals Page 3-5

Safety Signs and Instruction Signs Page 3-7About Safety Signs and Instruction
SignsPage 3-7Positions of Safety Decals and
Instruction Decals Page 3-7Description of Safety Decals and
Instruction Decals Page 3-8

Product Overview

Specifications

Specifications

Model		LM315GC (for greens)		LM315GC (for tees)		LM315GC (for fields)		
Dimensions	Total length		84.65 in	215 cm	←		←	
	Total width		79.92 in	203 cm	←		←	
	Total height	Steering wheel	51.97 - 55.51 in	132 - 141 cm	←		←	
Weight	2WD (empty fuel tank)	with ROPS and without Grass catcher, Groomer	1452.82 lb	659 kg	←		←	
	3WD (empty fuel tank)	with ROPS and without Grass catcher, Groomer	1507.94 lb	684 kg	←		←	
	Grass catcher (for one machine)		26.46 lb	12 kg	←		←	
	Groomer (for one machine)		22.05 lb	10 kg	←		←	
Minimum turning radius			354.94 in	161 cm	←		←	
Engine	Model		Kubota D722-E4B		←		←	
	Type		Vertical water-cooled 4- cycle diesel engine		←		←	
	Total displacement		43.87 cu.in.	719 cm ³ (0.719 L)	←		←	
	Maximum output		12.4 kW (16.9 PS)/ 3,000 rpm		←		←	
Fuel tank capacity			Diesel 5.28 U.S.gals	Diesel 20.0 dm ³ (20.0 L)	←		←	
Fuel consumption			210 g/PS · h (rated output)	286 g/kW · h (rated output)	←		←	
Engine oil capacity			0.74 U.S.gals	2.8 dm ³ (2.8 L)	←		←	
Coolant volume			0.79 U.S.gals	3.0 dm ³ (3.0 L)	←		←	
Hydraulic tank capacity			4.23 U.S.gals	16.0 dm ³ (16.0 L)	←		←	
Operating width (Mowing width)			59.84 in	152 cm	←		←	
Operating height (Mowing height)			0.059 - 0.709 in	1.5 - 18.0 mm	0.236 - 0.787 in	6.0 - 20.0 mm	0.394 - 1.575 in	10.0 - 40.0 mm
Blades			9 or 11		7		7	
Drive	Traveling		HST 2WD [3WD (2WD/3WD selectable)]		←		←	
	Mowing		Mechanical		←		←	
Speed (HST)	Forward		0 - 9.32 mph	0 - 15.0 km/h	←		←	

Product Overview

Speed (HST)	Reverse	0 - 3.73 mph [2WD selection of 3WD model: 0 - 5.59 mph]	0 - 6.0 km/h [2WD selection of 3WD model : 0 - 9.0 km/h]	←	←		
Speed (Mechanical)		-		←	←		
Efficiency		1.8 acres/hour (3.73 mph x mowing width x 0.8)	7,296 m ² /h (6.0 km/h x mowing width x 0.8)	←	←		
Maximum inclination for operation		15 degrees		←	←		
Tire size	Front wheel	Smooth 18 x 9.50-8 2P		Pillow Dia 18 x 8.50-8 4P	Smooth 18 x 9.50-8 2P		
	Rear wheel	Smooth 18 x 9.50-8 2P		Pillow Dia 18 x 8.50-8 4P	Smooth 18 x 9.50-8 2P		
Tire pneumatic pressure	Front wheel	11.60 psi	80 kPa (0.8 kgf/cm ²)	14.50 psi	100 kPa (1.0 kgf/cm ²)	11.60 psi	80 kPa (0.8 kgf/cm ²)
	Rear wheel	11.60 psi	80 kPa (0.8 kgf/cm ²)	14.50 psi	100 kPa (1.0 kgf/cm ²)	11.60 psi	80 kPa (0.8 kgf/cm ²)
Battery		55B24L (BCI GROUP SIZE 51R: Recommended equivalent product EXIDE 51R-60)		←	←		
Engine plug		-		←	←		

The factory default maximum engine rpm is 3,000 rpm.

Sound Pressure Level

Sound Pressure Level

This machine was confirmed to have a continuous A-weighted sound pressure level of 87 dB by measuring identical machines in accordance with the procedure specified in ISO 5395-1:2013.

Sound Power Level

Sound Power Level

This machine was confirmed to have a sound power level of 103 dB by measuring identical machines in accordance with the procedure specified in directive 2000/14/EC.

Vibration Level

Hand-Arm Vibration

This machine was confirmed not to exceed a vibration level of 2.5 m/s² to hands and arms by measuring identical machines in accordance with the procedure specified in ISO 5395-1:2013.

Whole Body Vibration

This machine was confirmed to transmit a vibration level of 0.61 m/s² to the whole body by measuring identical machines in accordance with the procedure specified in ISO 2631-1:1997, ISO 2631-2:2003.

Product Overview

Carbon Dioxide (CO₂) Emissions Measurement

For CO₂ emissions measurement on the engine of this machine, refer to the engine's owner's manual.

Names of Each Section

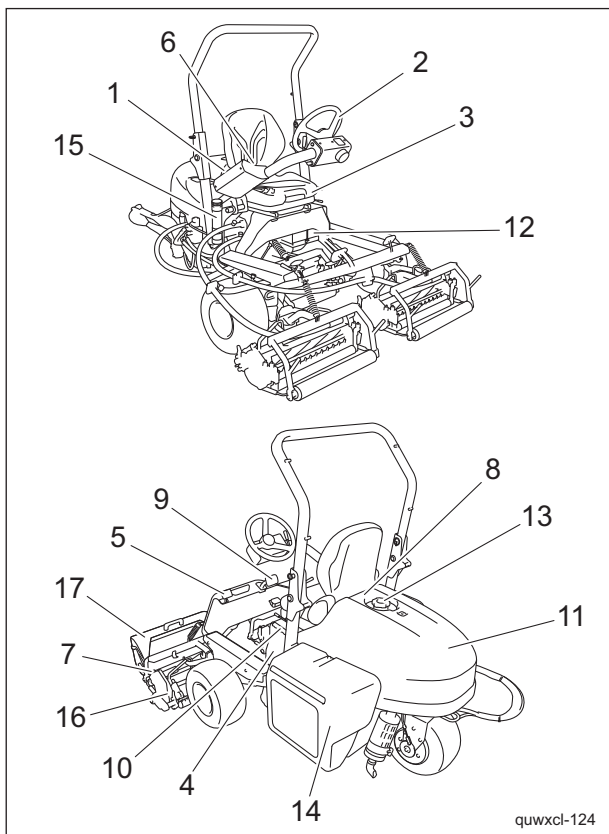

Names of Each Section_001

1	Operation panel
2	Steering wheel
3	Seat
4	Underseat cover
5	Mower pedal
6	Reel rotation switch
7	Reel reverse lever
8	Transmission selector lever
9	Traveling pedal
10	Parking brake lever
11	Hood
12	Battery
13	Fuel tank
14	Radiator cover
15	Box
16	Mower unit
17	Grass catcher

Regulation Decals

Positions of Regulation Decals

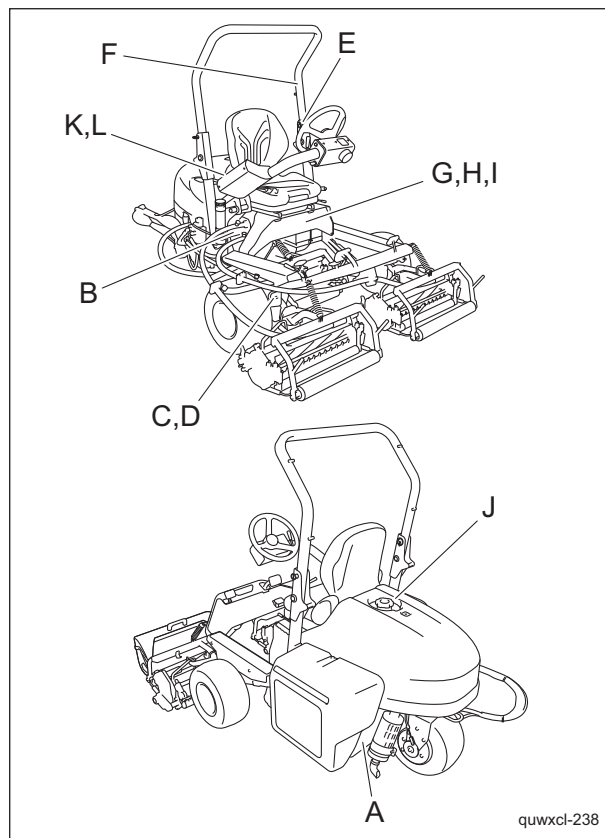

Positions of Regulation Decals_001

A	Serial number plate
B	Specification decal
C	Noise emission decal
D	Year of manufacture decal
E	ROPS compliance decal
F	ROPS caution decal
G	Battery capacity decal
H	Recycle decal
I	Battery danger decal
J	Indicating diesel fuel decal
K	California proposition 65 decal (riding type)
L	Spark arrester warning decal

Description of Regulation Decals

Serial Number Plate

The serial number plate indicates the model and serial number of the machine.

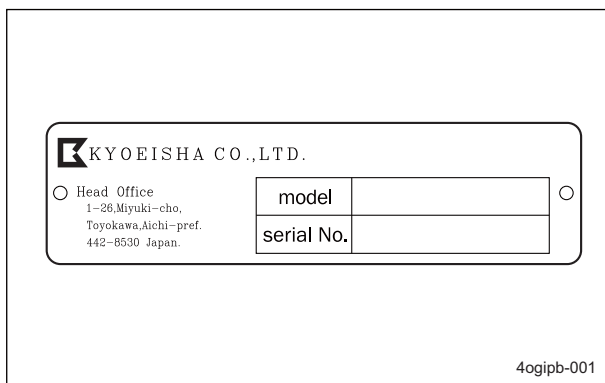

Serial Number Plate_001

Year of Manufacture Decal

(For Europe)

The year of manufacture decal indicates the year when this machine was manufactured.

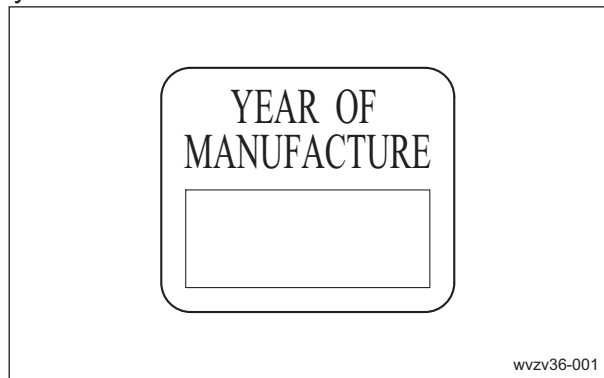

Year of Manufacture Decal_001

Specification Decal

(For Europe)

The Specification decal indicates the CE marking, model, and weight, etc.

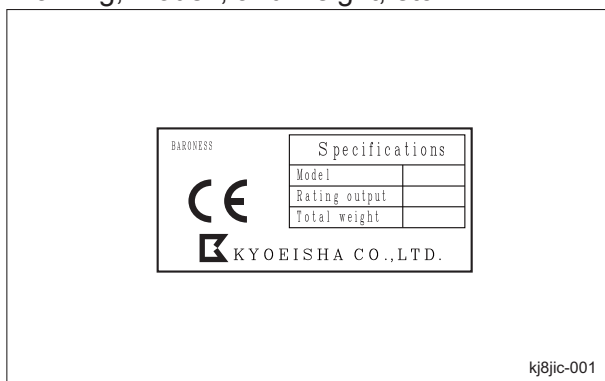

Specification Decal_001

ROPS Compliance Decal

The ROPS compliance decal indicates the manufacturer, model, etc., in accordance with International Standard ISO 21299:2009.

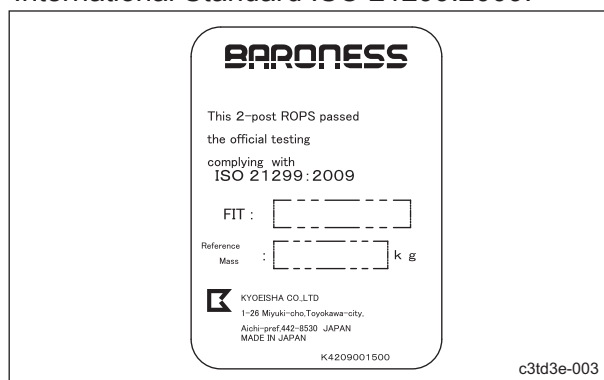

ROPS Compliance Decal_001

Noise Emission Decal

(For Europe)

The noise emission decal indicates the sound power level determined by measuring identical machines in accordance with the procedure specified in the EC directives.

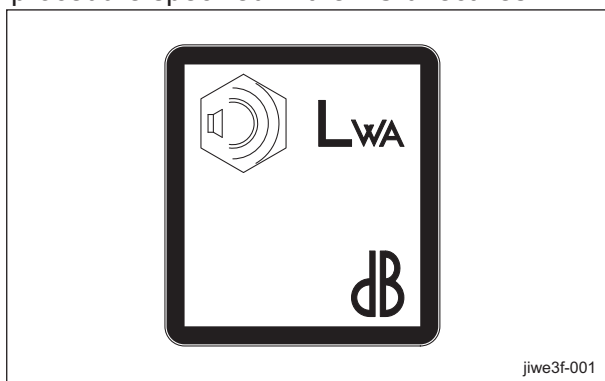

Noise Emission Decal_001

ROPS Caution Decal

ROPS caution decal describes the following caution messages.

- Replace damaged ROPS.
- Do not repair or revise.

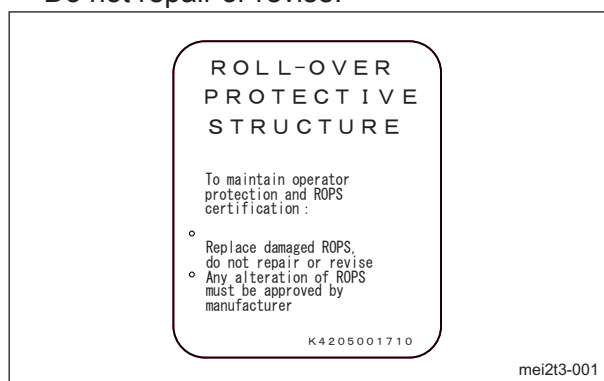

ROPS Caution Decal_001

Product Overview

Battery Capacity Decal

(For Europe)
The battery capacity decal indicates the capacity by 20HR and CCA.

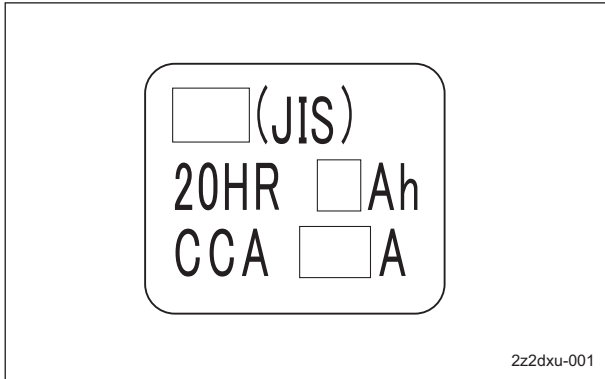

Battery Capacity Decal_001

Battery Danger Decal

(For USA)
Battery Danger Decal describes handling precautions for battery.

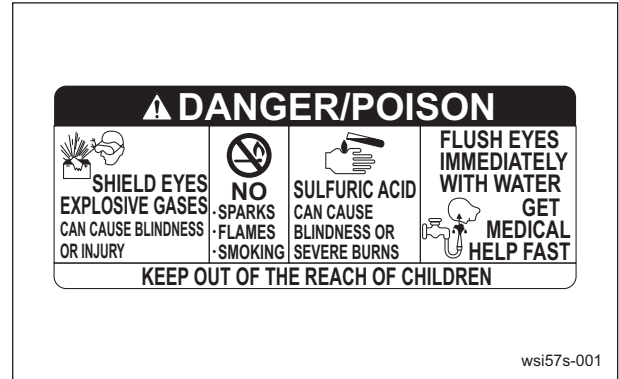

Battery Danger Decal_001

Recycle Decal

Recycle Decal illustrates Recycle Mark in accordance with local regulation.
(For Europe)

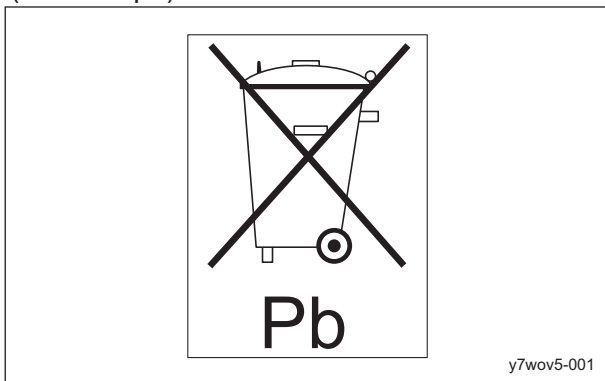

Recycle Decal_001

Indicating Diesel Fuel Decal

(for USA)
It indicates the fuel to be used.
Use low sulfur or ultra-low sulfur diesel fuel (sulfur-free diesel fuel).

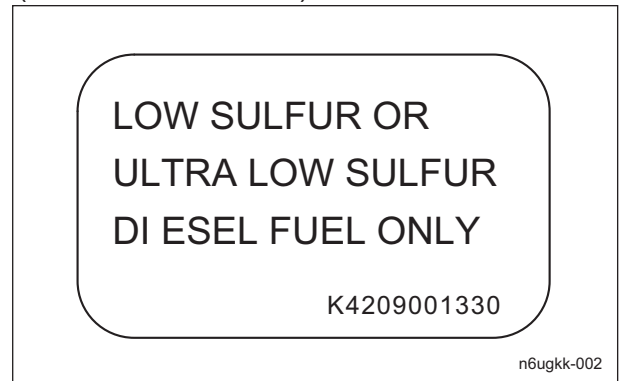

Indicating Diesel Fuel Decal_001

(For USA)



Recycle Decal_002

California Proposition 65 Decal (Riding Type)

(For the State of California, USA)
California Proposition 65 decal describes the warning messages as required by California Proposition 65.

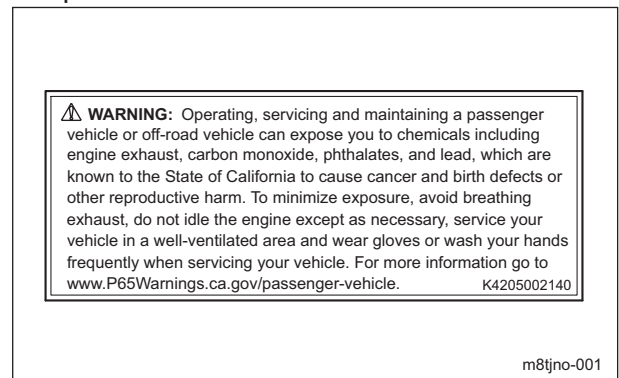

California Proposition 65 Decal (Riding Type)_001

Spark Arrester Warning Decal

(For the State of California, USA)

Spark arrester warning decal describes the warning messages as required by California Public Resources Code.

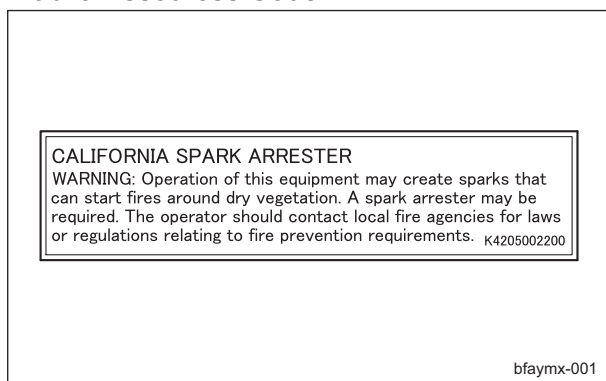

Spark Arrester Warning Decal_001

Safety Signs and Instruction Signs

About Safety Signs and Instruction Signs

Important

Safety decals and instruction decals are attached to this product. Make sure that they are preserved in their entirety. If they are damaged, become dirty, or peel off, replace them with new ones.

Part numbers for decals that need to be replaced are listed in the parts catalog. Order them from a Baroness dealer or Kyoeshia.

Positions of Safety Decals and Instruction Decals

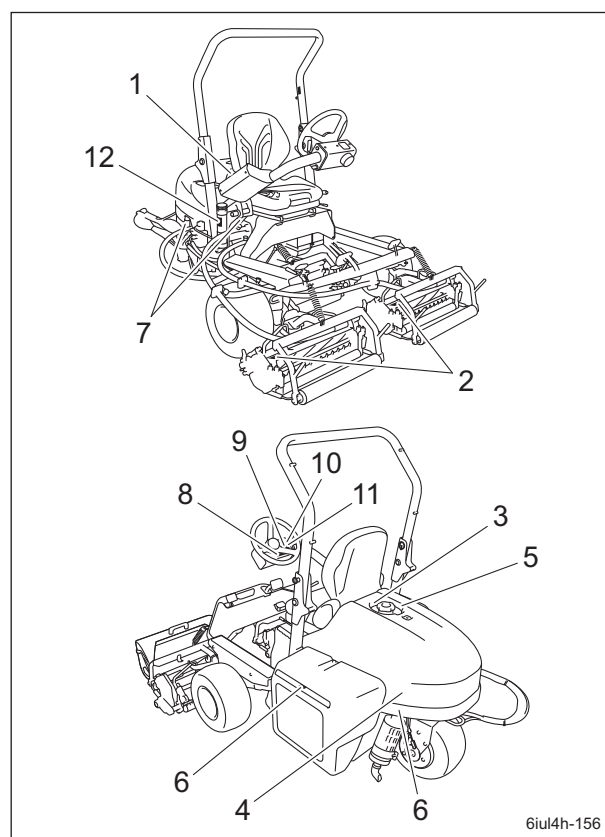

Positions of Safety Decals and Instruction Decals_001

1	D operation decal
2	Caution to mutilation decal
3	Fire prohibited decal
4	Hydraulic oil icon
5	Diesel fuel decal
6	Caution for high temperatures decal
7	Caution to getting entangled decal
8	Caution slope decal
9	Caution exhaust gas and flying object decal
10	Caution for slopes (3WD) decal
11	Caution to noise decal
12	Decal on reading owner's operating manual

Product Overview

Description of Safety Decals and Instruction Decals

D Operation Decal

LM315GC0504B0
Decal D, operation

1.



Read the Owner's Operating Manual.

2.



Apply the parking brake, stop the engine, and then remove the ignition key before leaving the machine.

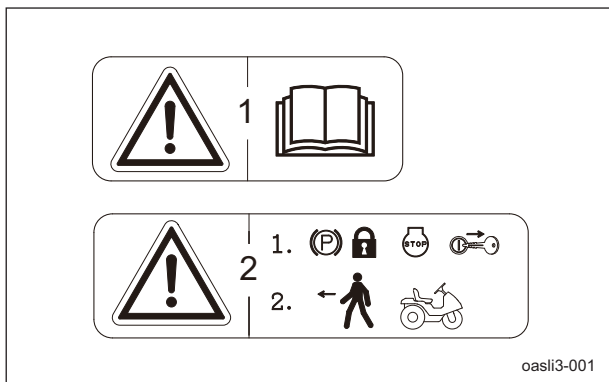

D Operation Decal_001

Caution to Mutilation Decal

K4205001600

DECAL, CAUTION TO MUTILATION



May cut your hand or leg - Stop the cutter rotation and engine. Otherwise you may get injured.

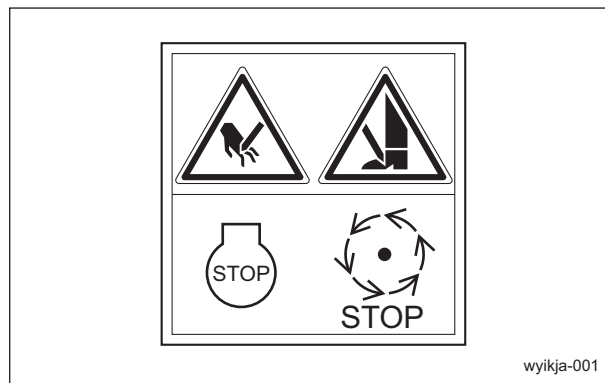

Caution to Mutilation Decal_001

Fire Prohibited Decal

K4205001940

Decal, fire prohibited



Keep away from fire.



Fire Prohibited Decal_001

Product Overview

Hydraulic Oil Icon

K4209000980
Hydraulic oil icon
Read the Owner's Operating Manual.

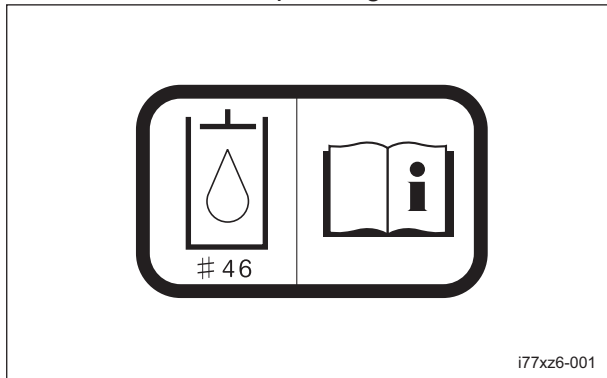

Hydraulic Oil Icon_001

Diesel Fuel Decal

K4209001460
Decal, diesel fuel
Use diesel fuel.

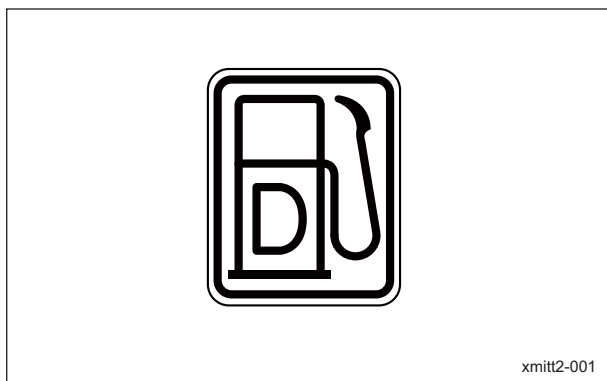

Diesel Fuel Decal_001

Caution for High Temperatures Decal

K4205001920
Decal, caution for high temperatures

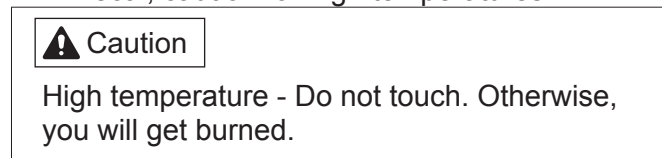

Caution for High Temperatures Decal_001

Caution to Getting Entangled Decal

K4205001910
Decal, caution to getting entangled

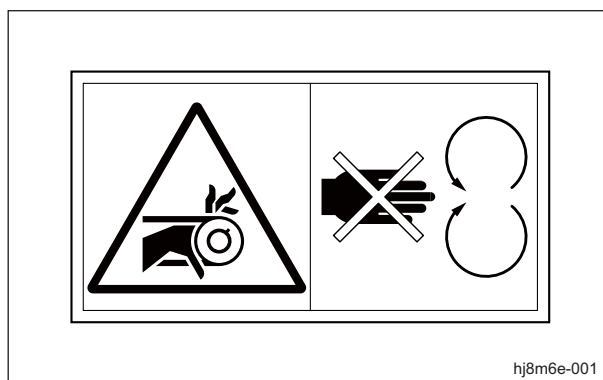
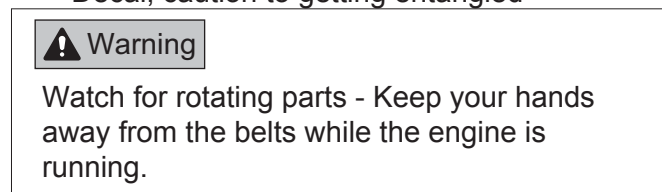

Caution to Getting Entangled Decal_001

Product Overview

Caution Slope Decal

K4205002040
Decal, caution slope

Caution

Rollover - Do not work on slopes of 15 degrees or more.
When you descend a slope, drive at low speed with the mower units lowered.
Fasten your seatbelt when the machine is equipped with ROPS.

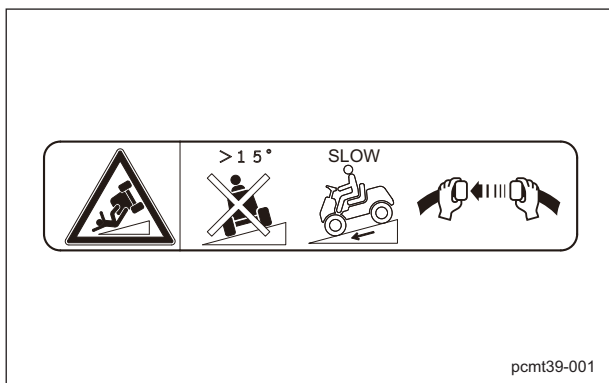

pcmt39-001

Caution Slope Decal_001

Caution Exhaust Gas and Flying Object Decal

K4205002050
Decal, caution flying object

Warning

Caution to exhaust gas diffusion - All persons other than the operator must keep a safe distance from the machine.

Caution

Flying objects - Be sure that people around the machine keep a safe distance away.

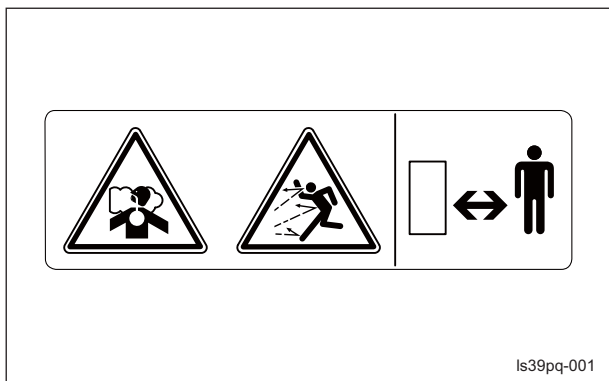

ls39pq-001

Caution Exhaust Gas and Flying Object Decal_001

Caution for Slopes (3WD) Decal

K4205002080
Decal, caution for slopes (3WD)
(3WD spec model only)

Warning

Rollover - Do not switch between 2WD and 3WD while traveling on downward slopes.
Do not set the reel rotation switch to the "Rotation" position while traveling on downward slopes.
Do not travel in three-wheel drive on downward slopes.

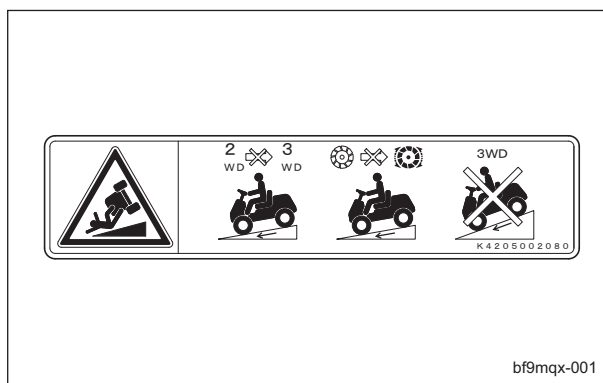

bf9mqx-001

Caution for Slopes (3WD) Decal_001

Caution to Noise Decal

K4205002090
Decal, caution to noise



bwu9po-001

Caution to Noise Decal_001

Decal on Reading Owner's Operating Manual

K4205001560

Decal, read Owner's Operating Manual

 Warning

Read the Owner's Operating Manual.

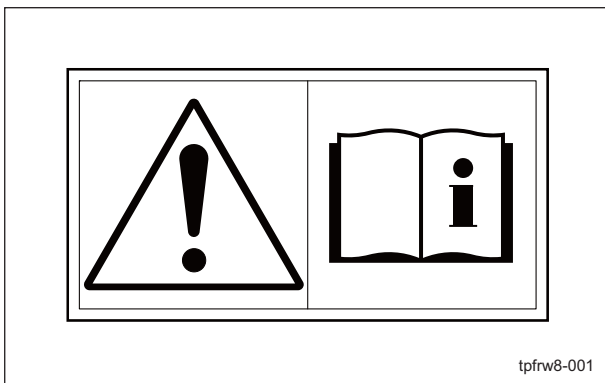

Decal on Reading Owner's Operating Manual_001

Product Overview

Handling Instructions

Inspections	Page 4-3	Warning Mechanisms	Page 4-26
Reel Cutter (Cutting Cylinder) and Bed Knife (Bottom Blade)	Page 4-3	Operation Method	Page 4-26
Cover	Page 4-3	Cautions for when You Leave The Machine	Page 4-26
Roller	Page 4-3	Positions of Operation Decals	Page 4-26
Radiator Cover	Page 4-3	Description of Operation Decals	Page 4-27
Dustproof Net	Page 4-4	Light Switch	Page 4-29
Radiator	Page 4-4	Throttle Lever	Page 4-30
Coolant	Page 4-5	Mower Pedal	Page 4-30
Hydraulic Oil	Page 4-6	Joystick	Page 4-31
Air Cleaner	Page 4-7	Mower Unit Up Switch	Page 4-31
Battery	Page 4-8	2WD/3WD Selector Switch	Page 4-32
Tire	Page 4-9	Reel Rotation Switch	Page 4-33
Brake	Page 4-9	Reel Reverse Lever	Page 4-33
Belt	Page 4-9	Transmission Selector Lever	Page 4-34
Wire	Page 4-9	Traveling Pedal	Page 4-34
Around The Engine	Page 4-9	Parking Brake Lever	Page 4-35
Engine Oil	Page 4-9	Hood	Page 4-35
Fuel	Page 4-10	Underseat Cover	Page 4-36
Fuel Filter	Page 4-12	Broom Holder	Page 4-36
Oil Leakage	Page 4-12	Swisher Holder	Page 4-37
Grass Catcher	Page 4-12	Instruments	Page 4-37
Tightening Torques	Page 4-13	Instruments on The Operation Panel ...	Page 4-37
Standard Tightening Torques	Page 4-13	Hour Meter	Page 4-37
Principal Tightening Torques	Page 4-15	Water Temperature Gauge	Page 4-38
Adjustment before Work	Page 4-17	Pilot Lamps	Page 4-38
Adjustment of Seat	Page 4-17	Fuel Gauge	Page 4-39
Adjustment of Armrest	Page 4-17	Travel of Machine	Page 4-39
Adjustment of Steering Wheel	Page 4-17	Moving The Machine	Page 4-39
Adjustment of Blade Engagement	Page 4-18	Towing The Machine	Page 4-40
Adjustment of Cutting Height	Page 4-19	Cutting Work	Page 4-40
Adjustment of Groomer	Page 4-21	Cutting Work	Page 4-40
Cutting Height and Blade Thickness of Bed Knife (Bottom Blade)	Page 4-23	Reel Excess Discharge System	Page 4-41
Adjustment of Cutter Adjustment Spring	Page 4-24	Removing Grass Catcher	Page 4-42
Procedure to Start/Stop Engine	Page 4-24	Transporting	Page 4-42
Start/Stop of Engine	Page 4-24	Transporting Procedure	Page 4-42
Safety Mechanisms	Page 4-26	Storage	Page 4-42

Handling Instructions

Before Long-Term StoragePage 4-42

Inspections

Inspect the machine according to the maintenance schedule so that you will be able to take advantage of its optimum performance for a long period of time.

Reel Cutter (Cutting Cylinder) and Bed Knife (Bottom Blade)

Inspection of Reel Cutter (Cutting Cylinder) and Bed Knife (Bottom Blade)

Caution

Wear gloves when touching edged tools to avoid cutting your hands.

The reel cutter (cutting cylinder) and bed knife (bottom blade) may become dull due to frequent use, objects crushed during mowing, or damage caused during transportation. Inspect the reel cutter (cutting cylinder) and bed knife (bottom blade), and if necessary, adjust the blade engagement, perform back lapping, or sharpen or replace the reel cutter (cutting cylinder) and the bed knife (bottom blade).

1. Check to see whether or not the edge of the reel cutter (cutting cylinder) and the bed knife (bottom blade) are too blunt to cut.
2. Make sure that the reel cutter (cutting cylinder) and the bed knife (bottom blade) are not cracked.
3. Check to see how much the reel cutter (cutting cylinder) and the bed knife (bottom blade) are worn.
4. Make sure that the reel cutter (cutting cylinder) and the bed knife (bottom blade) have not changed color due to heat from grinding.
5. Check to see whether or not the second edge face (relief) remains at the point of reel cutter (cutting cylinder).
6. Make sure that the welding between the reel cutter (cutting cylinder) and the disc has not come off.

Cover

Inspection of Covers

Warning

If you have removed the covers during inspection, be sure to securely install them in their original positions.

If a cover remains removed, the operator may come into contact with rotating parts or belts and foreign objects may fly off, possibly resulting in injuries.

1. Make sure that there is no wear or deterioration of the reel cover and all other covers.
2. Make sure that there is no damage to the reel cover and all other covers.
3. Make sure that there is no interference with moving parts due to deformation of the reel cover and all other covers.
4. Make sure that the reel cover and all other covers are installed in their appropriate positions.

Roller

Inspection of Rollers

Bearing wear due to frequent use or bearing damage caused by water infiltration may prevent the roller from rotating smoothly. Inspect the roller and, if necessary, replace parts such as oil seals and bearings.

1. Make sure that there is no abrasion nor adhesion of the roller.
2. Make sure that there is no wear of the roller shaft.
3. Make sure that there is no wear nor damage of the oil seal.
4. Make sure that there is no wear nor rust of the bearing.
5. Make sure that there is no play in the roller shaft.

Radiator Cover

Inspection of Radiator Cover

1. Make sure that there is no damage to the radiator cover.
2. Make sure that the radiator cover is not contaminated.

Handling Instructions

Dustproof Net

Inspection of Dust-Proof Mesh

1. Make sure that there is no damage to the dust-proof mesh.
2. Make sure that the dust-proof mesh is not contaminated.

Cleaning of Dust-Proof Mesh

Important

An unclean dust-proof mesh may cause overheating or damage to the engine. It may also cause malfunction of the hydraulic system.

If the dust-proof mesh has been contaminated with dust, be sure to clean it. Especially, after operating the machine in a dusty environment, it is important to remove dust as soon as possible.

1. Pull up the dust-proof mesh.

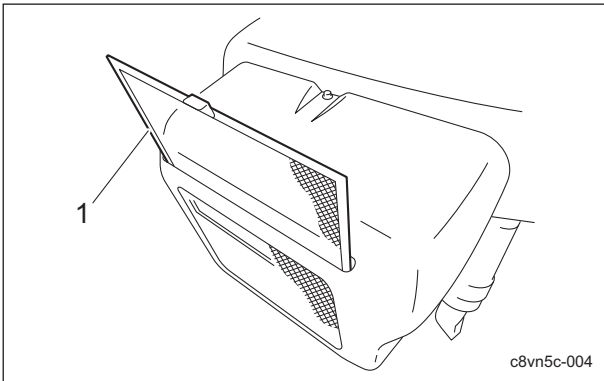

Cleaning of Dust-Proof Mesh_001

1	Dust-proof mesh
---	-----------------

2. Carefully clean the front and back of the dust-proof mesh with water or compressed air.

Radiator

Inspection of Radiator

1. Make sure that there is no damage to the radiator.
2. Make sure that the radiator is not contaminated.

Cleaning of Radiator

Important

An unclean radiator cover may cause overheating or damage to the engine. It may also cause malfunction of the hydraulic system.

Important

Do not use solid objects, such as a spatula or screwdriver, or high-pressure water to clean the radiator or oil cooler. Otherwise, special fins or tubes may be damaged, possibly resulting in reduced cooling performance or coolant leakage.

If the radiator has been contaminated with dust, be sure to clean it. Especially, after operating the machine in a dusty environment, it is important to remove dust as soon as possible.

1. Remove the bolt.
2. Open the radiator cover.
3. Pull up the dust-proof mesh upward and remove it.

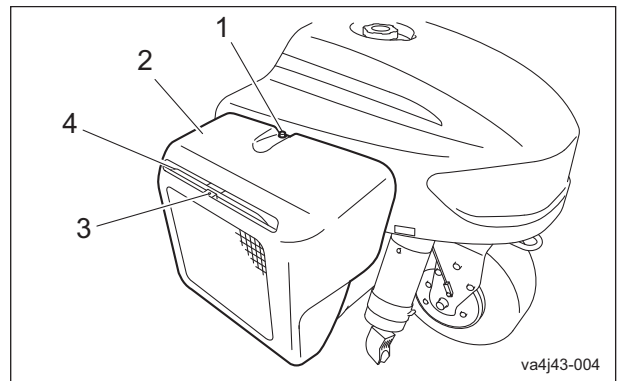

Cleaning of Radiator_001

1	Bolt
2	Radiator cover
3	Dust-proof mesh
4	Radiator

4. Carefully clean the front and back of the radiator with water or compressed air.

Handling Instructions

Coolant

Inspection of Coolant

⚠ Caution

Do not touch the radiator or coolant during engine operation or right after the engine has been turned off. Otherwise, you may get burned due to high temperatures.

⚠ Caution

Inspection should take place after the engine has well cooled down.

1. Make sure that the coolant level in the reserve tank is between "FULL" and "LOW."

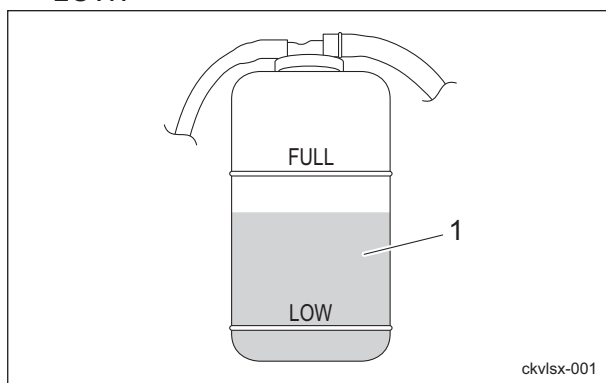

Inspection of Coolant_001

1	Reserve tank
---	--------------

Coolant Supply

⚠ Caution

Do not touch the radiator or coolant during engine operation or right after the engine has been turned off. Otherwise, you may get burned due to high temperatures. After the radiator has well cooled down, open the radiator cap.

⚠ Caution

Supply coolant after the engine has well cooled down.

⚠ Caution

The radiator cap is pressurized. If you remove the radiator cap while the engine is overheated, hot steam will burst out, possibly resulting in burns. Make sure that the water temperature and pressure are reduced, and then grab the cap with a thick cloth and gradually open the cap.

Important

When you supply coolant, be sure to use clean water, such as tap water.

Important

Tightly close the radiator cap. If the cap is loose or incorrectly installed, water may leak and the engine may overheat.

1. If the coolant level in the reserve tank is lower than the "LOW" mark, open the reserve tank cap and fill the tank with clean water up to the "FULL" mark.

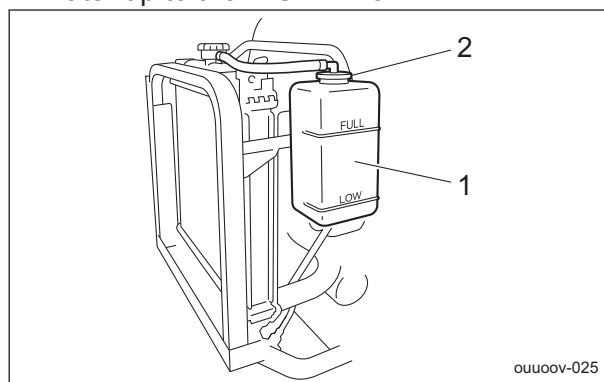

Coolant Supply_001

Handling Instructions

1	Reserve tank
2	Reserve tank cap

2. If no coolant is in the reserve tank, follow the steps below to fill the tank with clean water.

- [1] Open the radiator cap, and then supply clean water up to the opening.
- [2] Open the reserve tank cap, and then supply clean water up to the "FULL" mark.

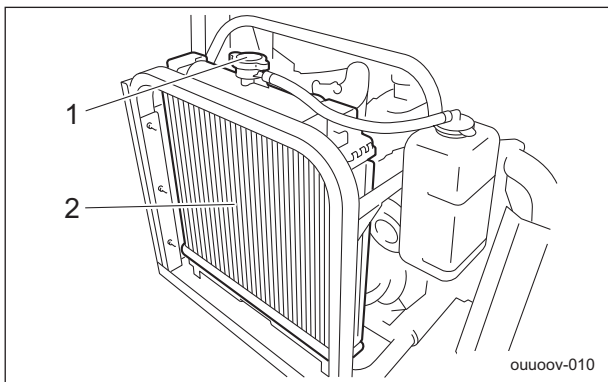

Coolant Supply_002

1	Radiator cap
2	Radiator

Hydraulic Oil

Inspection of Hydraulic Oil

- 1. Raise the mower units and maintain that position on a level surface.
- 2. Make sure that the oil level is at the middle of the oil gauge.

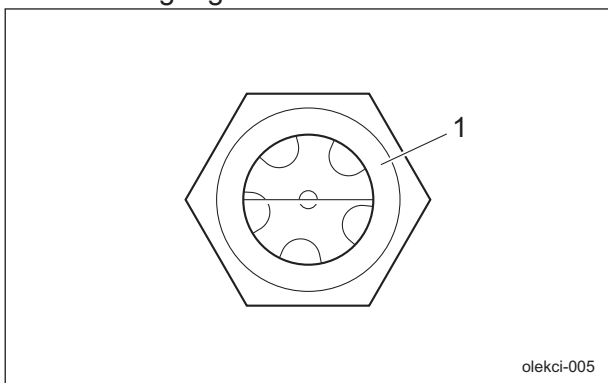

Inspection of Hydraulic Oil_001

1	Oil gauge
---	-----------

3. Check underneath the machine for oil leakage.

Hydraulic Oil Supply

Important

Do not mix different types of oil.

Important

Use Shell Tellus S2M46 (or equivalent) as hydraulic oil.

- 1. Open the hood.
- 2. Follow the steps below to supply oil if the oil level is low.

[1] Open the tank cap and supply oil from the fill port until the oil level reaches the middle of the oil gauge on the hydraulic tank.

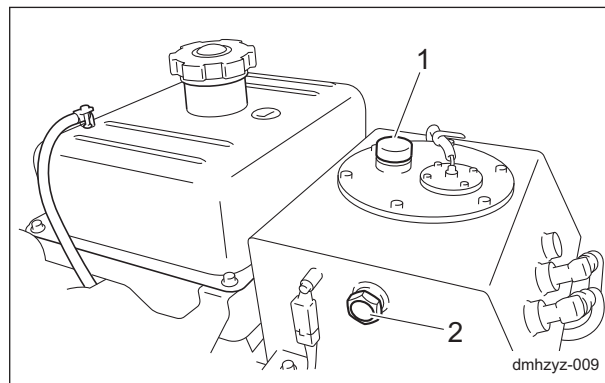

Hydraulic Oil Supply_001

1	Tank cap
2	Oil gauge

- [2] Tighten the tank cap securely.
- 3. Start the engine, raise and lower the mower units, and turn the steering wheel left and right. Move forward and reverse repeatedly several times.
- 4. Raise the mower units and maintain that position on a level surface, and then check to see if the oil level is at the middle of the oil gauge. If necessary, supply oil.
- 5. Check underneath the machine for oil leakage.
- 6. Close the hood.

Handling Instructions

Air Cleaner

Inspection of Air Cleaner

The air cleaner is a component that removes dirt from the intake air to prevent wear of the cylinder liners and piston rings so that the engine will always operate smoothly. A contaminated air cleaner element may cause malfunction of the engine.

1. Make sure that there is no damage to the air cleaner.
2. Make sure that the air cleaner element is not contaminated.

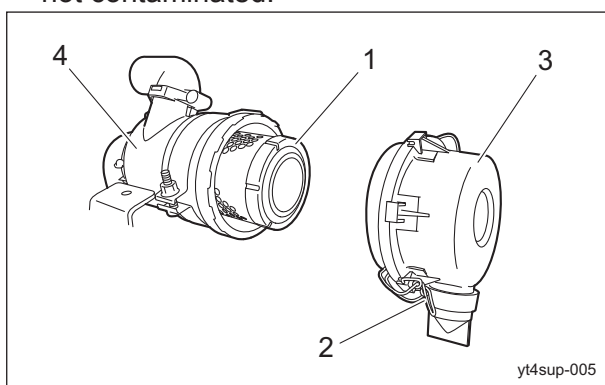

Inspection of Air Cleaner_001

1	Air cleaner element
2	Clip
3	Air cleaner cap
4	Air cleaner body

Cleaning of Air Cleaner

A contaminated air cleaner element may cause malfunction of the engine. To maximize the life of the engine, clean the air cleaner properly.

1. Remove the clips from the two locations and remove the air cleaner cap.
2. Remove the air cleaner element.
3. While paying close attention not to damage the air cleaner element, tap a solid portion of the air cleaner element or blow compressed air from its inside to remove dust and dirt.
If it is extremely smeared, replace with a new air cleaner element.
4. Open the evacuator valve and remove dust and dirt according to the maintenance schedule.
5. Attach the air cleaner element to the air cleaner body.

6. Replace the air cleaner cap, and then fix it securely with the clips.

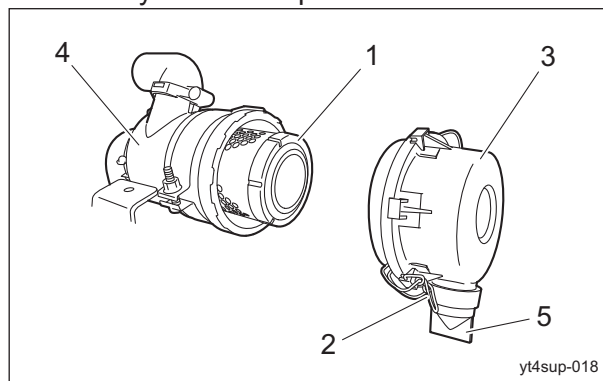

Cleaning of Air Cleaner_001

1	Air cleaner element
2	Clip
3	Air cleaner cap
4	Air cleaner body
5	Evacuator valve

Handling Instructions

Battery

Inspection of Battery

Danger

Keep fire away while inspecting or charging the battery.
The battery may explode.

Warning

Do not allow the battery fluid level to become lower than the LOWER LEVEL (minimum fluid level line).
The battery may explode if it is used or charged while the battery fluid level is at the LOWER LEVEL (minimum fluid level line).

Caution

Implement after the engine and muffler etc. have well cooled down.
Otherwise you may get burned.

1. Clean the areas around the battery fluid level lines using a cloth dampened with water.
2. Make sure that the battery fluid level is between the UPPER LEVEL (maximum fluid level line) and the LOWER LEVEL (minimum fluid level line).

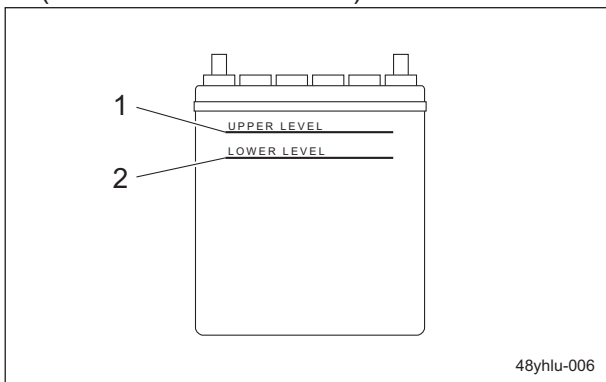

Inspection of Battery_001

1	UPPER LEVEL
2	LOWER LEVEL

Supply of Battery Fluid

Danger

Be careful not to let your skin, eyes or clothes, etc., come into contact with the battery fluid or accidentally swallow the fluid.
Should your skin or clothes come into contact with the battery fluid, immediately wash them away with water.

Danger

When you supply battery fluid, wear protective garments and safety glasses, etc.

Caution

Implement after the engine and muffler etc. have well cooled down.
Otherwise you may get burned.

1. If the battery fluid level is lower than halfway between the UPPER LEVEL (maximum) line and LOWER LEVEL (minimum) line, add purified water up to the UPPER LEVEL (maximum) line.

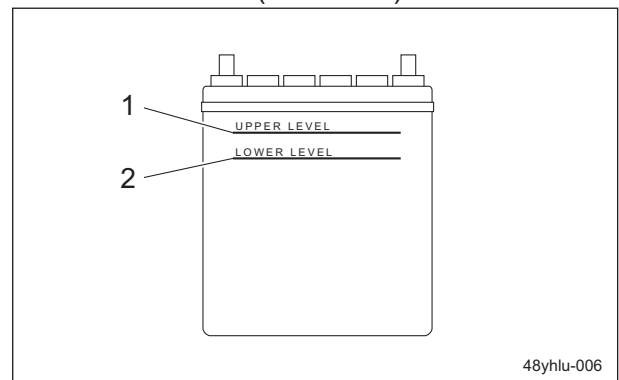

Supply of Battery Fluid_001

1	UPPER LEVEL
2	LOWER LEVEL

Handling Instructions

Tire

Inspection of Tires

1. Check the pneumatic pressure of the tires.
2. Make sure that there are no cracks, damage or abnormal wear.
(For green/For field)

	Tire size	Pneumatic pressure
Front wheel	Smooth 18 × 9.50-8 2P	80 kPa (0.8 kgf/cm ²)
Rear wheel	Smooth 18 × 9.50-8 2P	80 kPa (0.8 kgf/cm ²)

(For teeing ground)

	Tire size	Pneumatic pressure
Front wheel	Pillow Dia 18 × 8.50-8 4P	100 kPa (1.0 kgf/cm ²)
Rear wheel	Pillow Dia 18 × 8.50-8 4P	100 kPa (1.0 kgf/cm ²)

Brake

Inspection of Parking Brake

1. Make sure that the brake is applied when you pull the parking brake lever.
2. Make sure that the brake is not applied even slightly when you press the push button to release the parking brake lever.

Belt

Inspection of Belt

Warning

The engine must be stopped when the belt is inspected.

Important

A slacking or damaged belt or damaged fan may cause overheating or lack of a battery charge.

1. Press the middle of the belt with your finger to check the belt tension.
2. Make sure that there are no cracks, damage or abnormal wear.

Wire

Inspection of Wire

1. Make sure that the wire is not cracked or damaged.
2. If the wire is cracked or damaged, replace it with a new one immediately.

Around The Engine

Inspection of Engine-Associated Parts

1. Check the fuel system parts for loosened or cracked joints and leakage. Replace the parts if necessary.
2. Blow compressed air to clean any grass or flammable materials that may be attached on or around the muffler.

Engine Oil

Inspection of Engine Oil

Important

Securely tighten the oil level gauge and oil filler cap.

1. Stop the engine, wait for 10 to 20 minutes for the engine to cool down, and then check the oil level.
2. Position the machine so that the engine will be level, then insert the oil level gauge all the way to check the oil level.

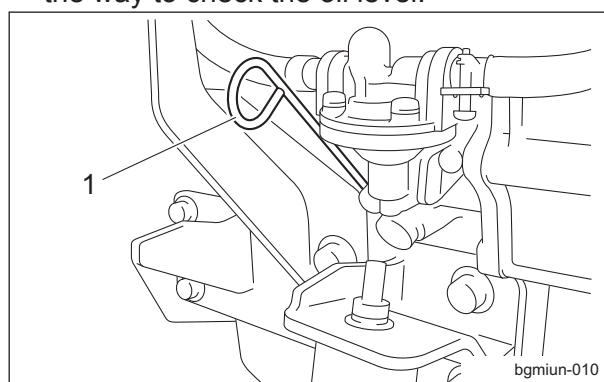

Inspection of Engine Oil_001

1 Oil level gauge

Handling Instructions

3. The appropriate oil level should be between the upper and lower limit lines on the gauge.

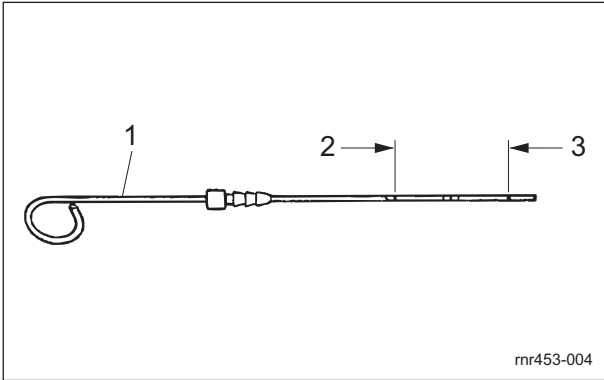

Inspection of Engine Oil_002

1	Oil level gauge
2	Upper limit
3	Lower limit

Supply of Engine Oil

For details on handling the engine, please refer to the separate Engine Handling Manual.

Important
Do not supply too much engine oil. Otherwise, the engine may be damaged.

Important
Do not mix different types of engine oil.

Important
Be sure to use engine oil that is classified as API Service Grade CF or higher, with an SAE Viscosity that is appropriate for the operating environment (ambient temperature).

Important
Securely tighten the oil level gauge and oil filler cap.

1. Engine oil is supplied through the oil filler cap.
Remove the oil filler cap, and then supply new engine oil until the oil reaches a level in between the upper and lower limit lines on the oil level gauge.

2. Replace the oil filler cap.

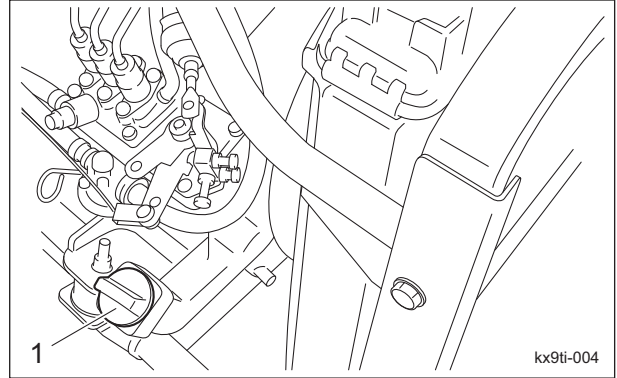

Supply of Engine Oil_001

1	Oil filler cap
---	----------------

3. It will take a while for the supplied engine oil to descend into the oil pan.
Check the oil level again 10 to 20 minutes after filling the oil.

Fuel

Inspection of Fuel Quantity

With the machine on a level surface, observe the fuel gauge on the fuel tank to check the fuel level.

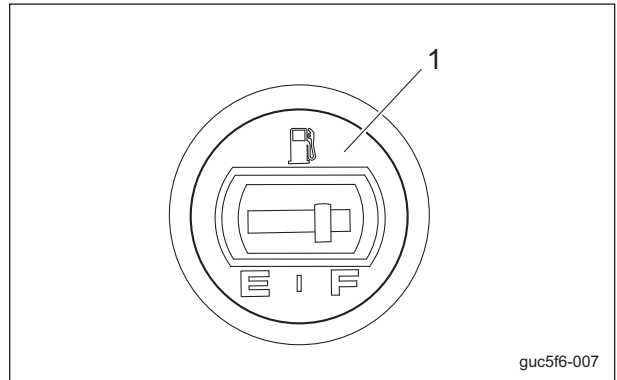

Inspection of Fuel Quantity_001

1	Fuel gauge
---	------------

Handling Instructions

Fuel Supply

Warning

Supply fuel before starting the engine. Never remove the tank cap or supply fuel while the engine is running. When opening the tank cap, wait at least 1 minute after stopping the engine, and then slowly open the cap to release the pressure in the tank. Opening the tank cap quickly may cause fuel to burst out.

Warning

Keep fire away while refueling. Do not smoke while refueling.

Warning

Do not supply fuel above F (FULL) level of the fuel gauge. If you supply too much fuel, it might overflow from the fuel cap when you travel or work on a slope.

If the fuel gauge on the fuel tank indicates a level close to E (EMPTY), supply fuel (diesel) at your earliest convenience.

The fuel tank capacity is approximately 20.0 dm³ (20.0 L).

Note:

If the cargo box installed, slide it backward before supplying fuel.

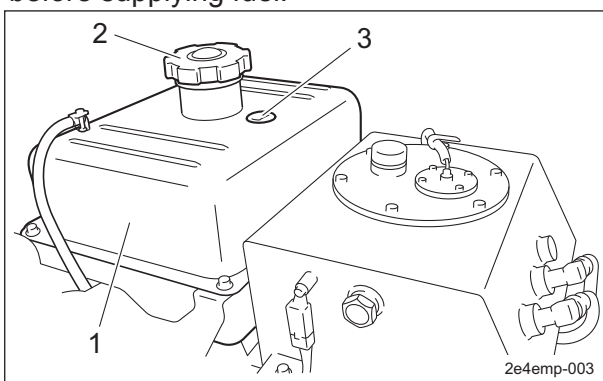

Fuel Supply_001

1	Fuel tank
2	Tank cap
3	Fuel gauge

Air Bleeding of Fuel System

Important

Be sure to tighten the air-bleeding plug except when air bleeding. Otherwise, it may cause the engine stop.

1. Fill up the fuel tank with fuel and open the fuel cock.
2. Loosen the air-bleeding plug of the fuel filter 2 to 3 turns.
3. If air bubble of the fuel from the plug has gone, tighten the plug.

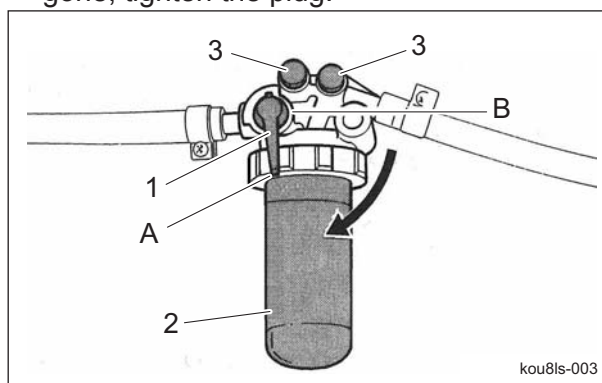

Air Bleeding of Fuel System_001

1	Fuel cock
2	Fuel filter
3	Air-bleeding plug
A	ON (Open)
B	OFF (Close)

4. Loosen the air-bleeding plug of the injection pump.

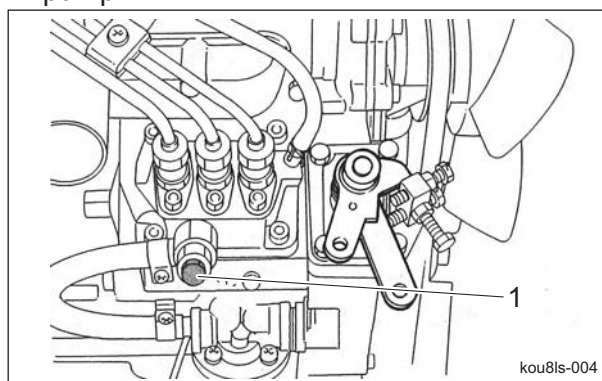

Air Bleeding of Fuel System_002

1	Air-bleeding plug
---	-------------------

5. Sit on the operator's seat.
6. Make sure that the parking brake is applied.
7. Turn the reel rotation switch to the "STOP" side.

Handling Instructions

8. Make sure that the traveling pedal is neutral.
9. Set the ignition key to "START" position.

Important

In the case that there are still air bubbles in the fuel from air-bleeding plug even after 15 seconds or more pass after setting the ignition key to "START", pause for 30 seconds or more and then repeat the same steps.

10. If the starter rotates and air bubble of the fuel from the air-bleeding plug has gone, return the ignition key slowly to "OFF" position and tighten the plug.

Fuel Filter

Inspection of Fuel Filter

The fuel filter works to remove foreign objects mixed into the fuel.

When the fuel flow becomes insufficient, replace the fuel filter if necessary.

1. Make sure that there is no fuel leakage.
2. Make sure that the fuel filter is not damaged or dirty.

Oil Leakage

Inspection of Oil Leakage

⚠ Caution

When performing maintenance on the hydraulic system, lower the mower units.

After approximately 50 hours of operation, some tightened portions may be loosened and oil and grease may leak.

Be sure to retighten the parts.

Check the bottom of the machine for oil and grease leakage.

Grass Catcher

Inspection of Grass Catcher

The grass catcher may no longer correctly collect grass clippings due to its wear, damage, deformation, etc., caused by frequent use.

1. Make sure that there is no wear or deterioration of the grass catcher.
2. Make sure that there is no damage to the grass catcher.
3. Make sure that there is no interference to moving parts due to deformation of the grass catcher.

Tightening Torques

Important

Refer to the Tightening Torque table.
Note that the Baroness product warranty may not apply to defects caused by incorrect or overtorque tightening, etc.

Standard Tightening Torques

Bolts and Nuts

Important

A number of bolts are used in each part of this machine.
Be sure to re-tighten the bolts and nuts, because they may be loosened at the earlier stage of the use.

As to the bolts and nuts without any special instruction, tighten them in appropriate tightening torque with proper tool.

Too much tightening may cause the looseness or damage of the screw.

The strength of tightening is determined by types of screws, strength, the friction of thread face or base face and others.

The table below is for the galvanized or parkerized bolts.

In case that the strength of internal thread is weak, it is not applied.

Do not use rusty or sand attached "screw."

Otherwise, it may cause insufficient tightening even if you apply the specified tightening torque.

The friction of the screw face becomes higher and the tightening torque is canceled out by the friction, therefore sufficient tightening cannot be applied.

If "screw" is wet by water or oil, do not tighten it with normal tightening torque.

If the screw is wet, the torque coefficient will get smaller and it may result in too much tightening.

Too much tightening may cause looseness by the screw stretched or result in damage.

Do not use a bolt experienced too much burden.

Using the impact wrench requires the skill.

Do exercise as much as possible for steady tightening.

Handling Instructions

Nominal diameter	General bolt		
	Strength classification 4.8		
			
	N-m	kgf-cm	lb-in
M5	3 - 5	30.59 - 50.99	26.55 - 44.26
M6	7 - 9	71.38 - 91.77	61.96 - 79.66
M8	14 - 19	142.76 - 193.74	123.91 - 168.17
M10	29 - 38	295.71 - 387.49	256.68 - 336.34
M12	52 - 67	530.24 - 683.20	460.25 - 593.02
M14	70 - 94	713.79 - 958.52	619.57 - 831.99
M16	88 - 112	897.34 - 1142.06	778.89 - 991.31
M18	116 - 144	1,182.85 - 1,468.37	1,026.72 - 1,274.54
M20	147 - 183	1,498.96 - 1,866.05	1,301.10 - 1,619.73
M22	295	3,008.12	2,611.05
M24	370	3,772.89	3,274.87
M27	550	5,608.35	4,868.05
M30	740	7,545.78	6,549.74

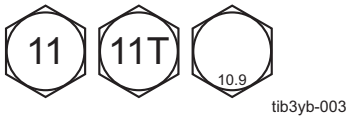
Nominal diameter	Heat-treated bolt					
	Strength classification 8.8			Strength classification 10.9		
						
	N-m	kgf-cm	lb-in	N-m	kgf-cm	lb-in
M5	5 - 7	50.99 - 71.38	44.26 - 61.96	7 - 10	71.38 - 101.97	61.96 - 88.51
M6	8 - 11	81.58 - 112.17	70.81 - 97.36	14 - 18	142.76 - 183.55	123.91 - 159.32
M8	23 - 29	234.53 - 295.71	203.57 - 256.68	28 - 38	285.52 - 387.49	247.83 - 336.34
M10	45 - 57	458.87 - 581.23	398.30 - 504.51	58 - 76	591.43 - 774.97	513.36 - 672.68
M12	67 - 85	683.20 - 866.75	593.02 - 752.34	104 - 134	1,060.49 - 1,366.40	920.50 - 1186.03
M14	106 - 134	1,080.88 - 1,366.40	938.21 - 1,186.03	140 - 188	1,427.58 - 1,917.04	1,239.14 - 1,663.99
M16	152 - 188	1,549.94 - 1,917.04	1,345.35 - 1,663.99	210 - 260	2,141.37 - 2,651.22	1,858.71 - 2,301.26
M18	200 - 240	2,039.40 - 2,447.28	1,770.20 - 2,124.24	280 - 340	2,855.16 - 3,466.98	2,478.28 - 3,009.34
M20	245 - 295	2,498.27 - 3,008.12	2,168.50 - 2,611.05	370 - 450	3,772.89 - 4,588.65	3,274.87 - 3,982.95
M22	-	-	-	530	5,404.41	4,691.03
M24	-	-	-	670	6,831.99	5,930.17
M27	-	-	-	1,000	10,197.00	8,851.00
M30	-	-	-	1,340	14,628.78	11,860.34

Note:

The same values are applied to "fine screw thread."

Handling Instructions

Principal Tightening Torques

Tightening Torque by Model

LM315GC

Tighten the following bolts and nuts at the torque specified in the table.

For thread locking adhesive, apply a middle strength thread locker (ThreeBond 1322 or equivalent anaerobic sealant).

Location	Code	Part name	Tightening torque			Thread locking adhesive
			N-m	kgf-cm	lb-in	
Front frame	K0010080202	Bolt, heat-treated M8-20	23 - 38	234.53 -387.49	203.57 - 336.34	-
Engine coupling	Joint	K0010080152	23 - 38	234.53 -387.49	203.57 - 336.34	-
	Belt collar	K0010080302	23 - 38	234.53 -387.49	203.57 - 336.34	-
Diesel engine	Engine mount	K0017100252	45 - 57	1835.46 - 2039.40	1593.18 - 1770.20	-
	Wire mounting adjuster	K0011100302	45 - 57	1835.46 - 2039.40	1593.18 - 1770.20	-
	Muffler mounting adjuster	K0011100352	45 - 57	1835.46 - 2039.40	1593.18 - 1770.20	-
	Pulley mounting adjuster	K0010080202	23 - 38	234.53 -387.49	203.57 - 336.34	-
	Engine pulley D	K0010080202	23 - 38	234.53 -387.49	203.57 - 336.34	-
	Clamping plates	K0010080252	14 - 19	142.76 - 193.74	123.91 - 168.17	-
Front wheel	Wheel	K0010100302	58 - 76	591.43 - 774.97	513.36 - 672.68	-
	Wheel mounting base	K0138240002	180 - 200	1835.46 - 2039.40	1593.18 - 1770.20	-
3WD rear wheel	Motor	K0000120502	52 - 67	530.24 - 683.20	460.25 - 593.02	-
	Wheel	K0013101202	58 - 76	591.43 - 774.97	513.36 - 672.68	-
	Wheel mounting base	K0138240002	180 - 200	1835.46 - 2039.40	1593.18 - 1770.20	-
	Brake Assy	K0010080252	14 - 19	142.76 - 193.74	123.91 - 168.17	-
2WD rear wheel	Wheel	K0010100302	45 - 57	1835.46 - 2039.40	1593.18 - 1770.20	-
	Brake drum	K0010100302	45 - 57	1835.46 - 2039.40	1593.18 - 1770.20	-

Handling Instructions

Location	Code	Part name	Tightening torque			Thread locking adhesive	
			N-m	kgf-cm	lb-in		
Mower unit	Reel shaft	LM315GB2102Z0	Reel gear fixing nut	2.5	25.49	22.13	-
	Reel shaft (with Groomer)	LM315GB2101Z0	20-tooth reel gear	2.5	25.49	22.13	-
	Bed knife (Bottom blade)	K0071000222	Screw, heat-treated flathead M6-12	7 - 9	71.38 - 91.77	61.96 - 79.66	-
	Groomer reel	K0160000602	17 special nut P1M4	5 - 10	50.99 - 101.97	44.26 - 88.51	-
	Gearbox	LM315GA1817Z0	Reverse shaft	52 - 67	530.24 - 683.20	460.25 - 593.02	○
		LM315GA1816Z0	Intermediate shaft	52 - 67	530.24 - 683.20	460.25 - 593.02	○
	Front roller	K6083000042	Connected pin, 15-19	29 - 38	295.71 - 387.49	256.68 - 336.34	-
		K0071000152	Bolt, Left-handed Thread	29 - 38	295.71 - 387.49	256.68 - 336.34	-
	Groomer mounting	K6809000270	Screw	18	183.55	159.32	-
		LM315GA1835Z0	Mower mounting bolt, left	20	203.94	177.02	-
		LM315GA1836Z0	Mower mounting bolt, right	20	203.94	177.02	-
	ROPS pillar right/left	K0010120402	Bolt, heat-treated M12-40	104 - 134	1,060.49 - 1,366.40	920.5 - 1,186.3	-
CR Brush	LM315GC7603Z2	Pulley, reel shaft	14 - 19	142.76 - 193.74	123.91 - 168.17	○	

Adjustment before Work

Adjustment of Seat

Use the seat adjustment levers to adjust the seat.

Adjust the position according to the operator's body size.

Important

After adjustment of the seat, make sure that the backrest does not interfere with the hood with the operator seated.

1. Use the forward/backward adjustment lever to adjust the seat back and forth.
2. Use the backrest tilt adjustment lever to adjust the angle of the backrest.
3. Pull out the suspension adjustment handle and move it up or down to adjust the firmness of the seat suspension. Observe the suspension adjustment scale while making adjustments. (50 - 160 kg)
4. The seat can be adjusted to one of two levels by pulling up the forward tilt angle adjustment lever.

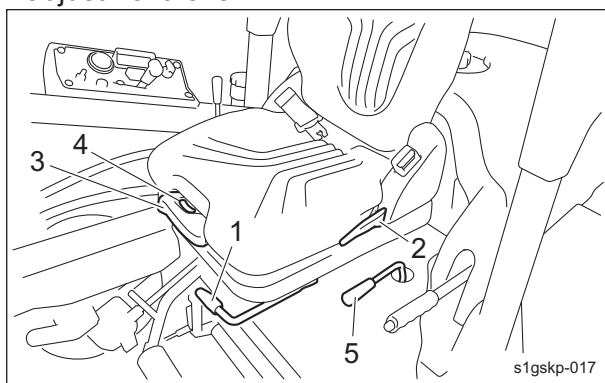

Adjustment of Seat_001

1	Forward/backward adjustment lever
2	Angle adjustment lever
3	Suspension adjustment handle
4	Suspension adjustment scale
5	Forward tilt angle adjustment lever

Adjustment of Armrest

Note:

Depending on the specifications, this function may not be available.

The armrest angle can be adjusted by turning the armrest adjustment knob.

Adjust it to fit the operator.

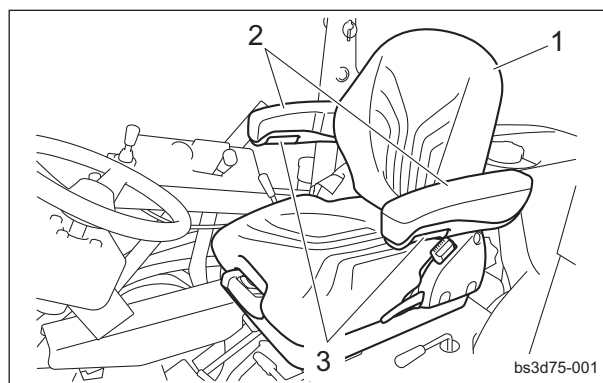

Adjustment of Armrest_001

1	Seat
2	Armrest
3	Armrest adjustment knob

Adjustment of Steering Wheel

Warning

Since it is dangerous, do not adjust the steering wheel while traveling.

Caution

Be sure the steering wheel position is securely locked. It may result in an unexpected accident if it becomes loose while traveling.

Caution

When operating the height adjustment lever, be careful not to pinch your hands.

The steering wheel arm can be adjusted up or down.

Adjust the position according to the operator's body size.

Pull up the height adjustment lever, position the steering wheel arm to a proper position for your work and push down the height adjustment lever to lock it.

The height adjustment lever is attached to the right of the seat.

Handling Instructions

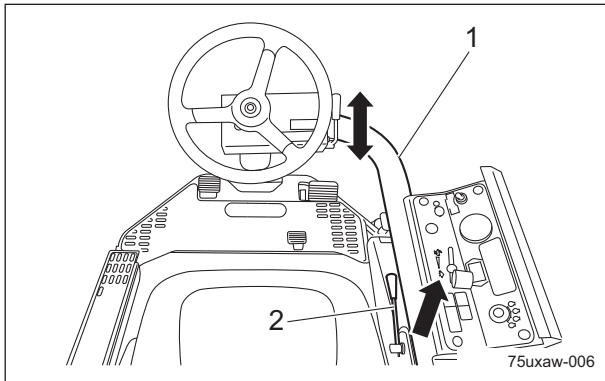

Adjustment of Steering Wheel_001

1	Steering wheel arm
2	Height adjustment lever

The steering wheel angle can be adjusted up or down.
Adjust the position according to the operator's body size.
Pull the angle adjustment lever, position the steering wheel to a proper position for your work and push the angle adjustment lever forward to lock it.
The angle adjustment lever is attached to the right of the steering wheel.

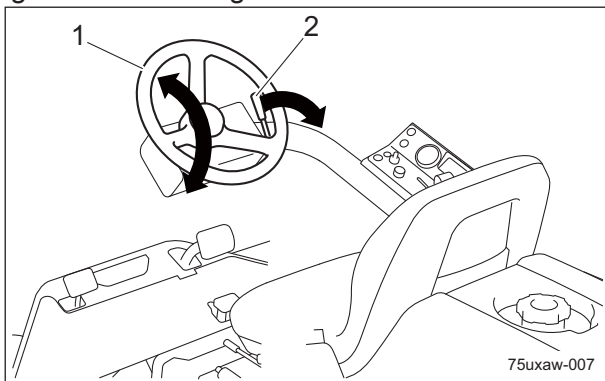

Adjustment of Steering Wheel_002

1	Steering wheel
2	Angle adjustment lever

Adjustment of Blade Engagement

⚠ Caution

When handling the reel cutter (cutting cylinder) or bed knife (bottom blade), wear gloves to protect your hands. Pay attention not to let the reel cutter (cutting cylinder) catch your gloves. Otherwise, you may injure your hand or fingers.

1. Stop the engine.
2. Set the reel reverse lever to the "Neutral" position.

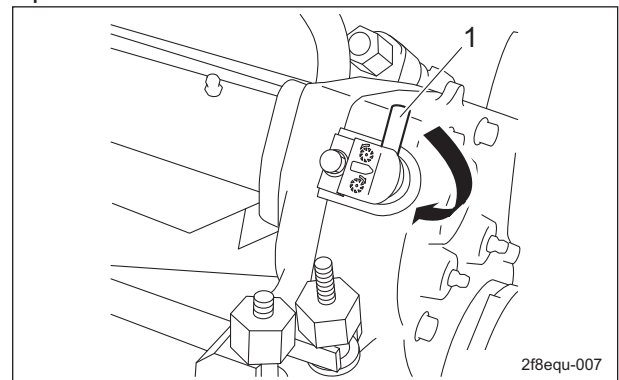

Adjustment of Blade Engagement_001

1	Reel reverse lever
---	--------------------

3. Adjust the engagement between the reel cutter (cutting cylinder) and the bed knife (bottom blade) so that newspaper (one piece) will be cut cleanly by the edge of both blades when the blades in their entirety come slightly into contact with each other via the cutter adjustment nuts.
4. Insert a strip of newspaper into the space between the reel cutter (cutting cylinder) and the bed knife (bottom blade) at an angle of 90 degrees. Then, rotate the reel cutter (cutting cylinder) counter-clockwise (when you face the mower unit from the left) to check the sharpness of the blades. Check the sharpness of the entire range (three or four points) of the reel cutter (cutting cylinder).
 - If a gap is created between edges: Loosen (rotate counter-clockwise) the cutter adjustment nut to apply more contact pressure between the reel cutter (cutting cylinder) and the bed knife (bottom blade).

Handling Instructions

- If the reel cutter (cutting cylinder) is too tight to turn:
Tighten (rotate clockwise) the cutter adjustment nut to reduce the contact pressure between the reel cutter (cutting cylinder) and the bed knife (bottom blade).
- If the sharpness is not improved by the adjustment:
Perform back lapping.

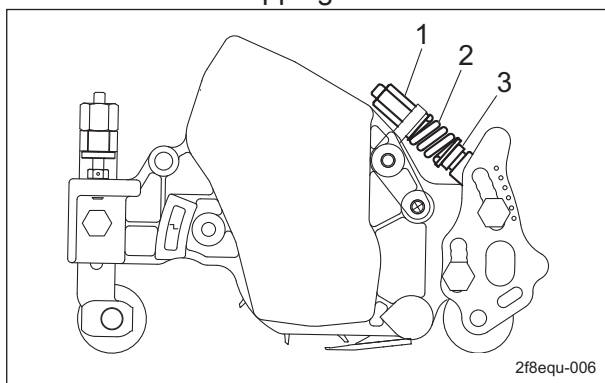

Adjustment of Blade Engagement_002

1	Cutter adjustment nut
2	Spring
3	Pipe with cutter adjusting screw

Adjustment of Cutting Height

Adjust the cutting height to fit your cutting work.

Important

This applies the set cutting height that differs from the actual cutting height.

Adjustment of Rear Roller

LM315GC (for greensmowing)

You can adjust the rear roller by six stages.

1. Attach the rear roller in a position that suits your work requirements within the cutting height range.

Note:

The figure below shows the position of the rear roller bracket with a new reel cutter when using a 2.0 mm bed knife. The lowest cutting height differs with thickness of the bed knife.

"Cutting Height and Blade Thickness of Bed Knife (Bottom Blade)" (Page 4-23)

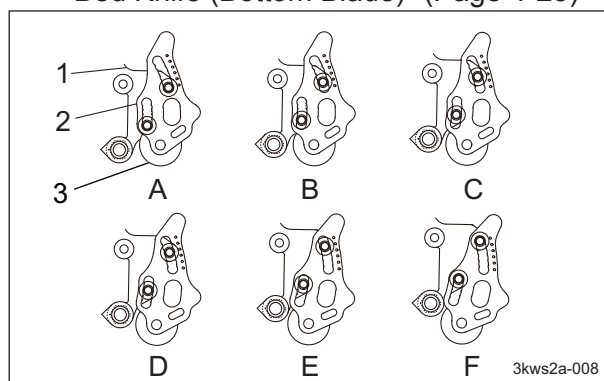

Adjustment of Rear Roller_001

1	Mower frame
2	Rear roller bracket
3	Rear roller
A	Use when the reel cutter is worn out
B	3.5 - 5.0 mm (0.138 - 0.197 in)
C	3.5 - 10.0 mm (0.138 - 0.394 in)
D	10.0 - 14.0 mm (0.394 - 0.551 in)
E	14.0 - 18.0 mm (0.551 - 0.709 in)
* F	18.0 - 20.0 mm (0.709 - 0.787 in)

* Not recommended by manufacturer.

Note:

If the cutting height was the same with settings B and C, the volume of mowing would be larger with C since the offset distance is larger.

Handling Instructions

LM315GC (for tee mowing)

You can adjust the rear roller by eight stages.

1. Attach the rear roller in a position that suits your work requirements within the cutting height range.

Note:

The figure below shows the position of the rear roller bracket with a new reel cutter using 3.0 mm bed knife.

The lowest cutting height differs with thickness of the bed knife.

"Cutting Height and Blade Thickness of Bed Knife (Bottom Blade)" (Page 4-23)

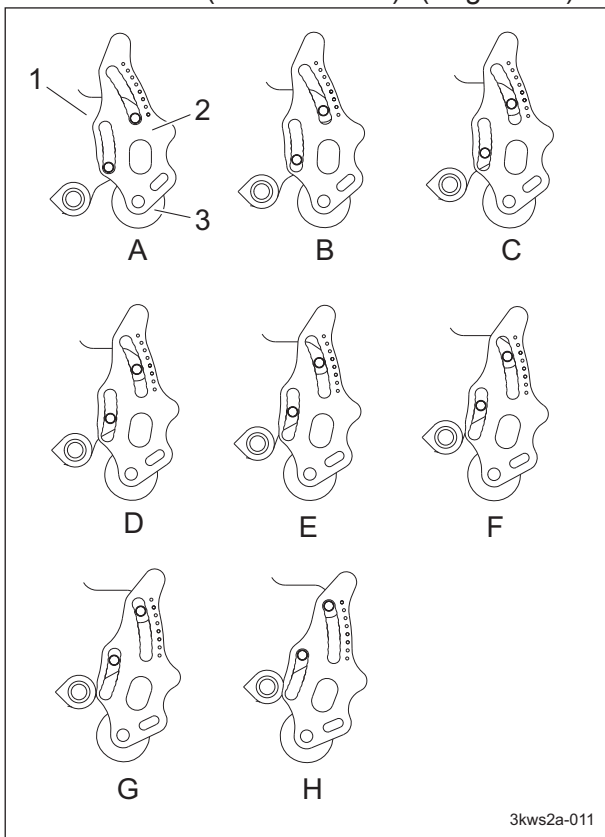

Adjustment of Rear Roller_002

1	Mower frame
2	Rear roller bracket
3	Rear roller
A	Use when the reel cutter is worn out
B	6.0 - 13.0 mm (0.236 - 0.512 in)
C	13.0 - 17.0 mm (0.512 - 0.669 in)
D	17.0 - 20.0 mm (0.669 - 0.787 in)
* E	20.0 - 25.0 mm (0.787 - 0.984 in)
* F	25.0 - 28.0 mm (0.984 - 1.102 in)
* G	28.0 - 32.0 mm (1.102 - 1.260 in)
* H	32.0 - 35.0 mm (1.260 - 1.378 in)

* Not recommended by manufacturer.

LM315GC (for field mowing)

You can adjust the rear roller by eight stages.

1. Attach the rear roller in a position that suits your work requirements within the cutting height range.

Note:

The figure below shows the position of the rear roller bracket with a new reel cutter using 3.0 mm bed knife.

The lowest cutting height differs with thickness of the bed knife.

"Cutting Height and Blade Thickness of Bed Knife (Bottom Blade)" (Page 4-23)

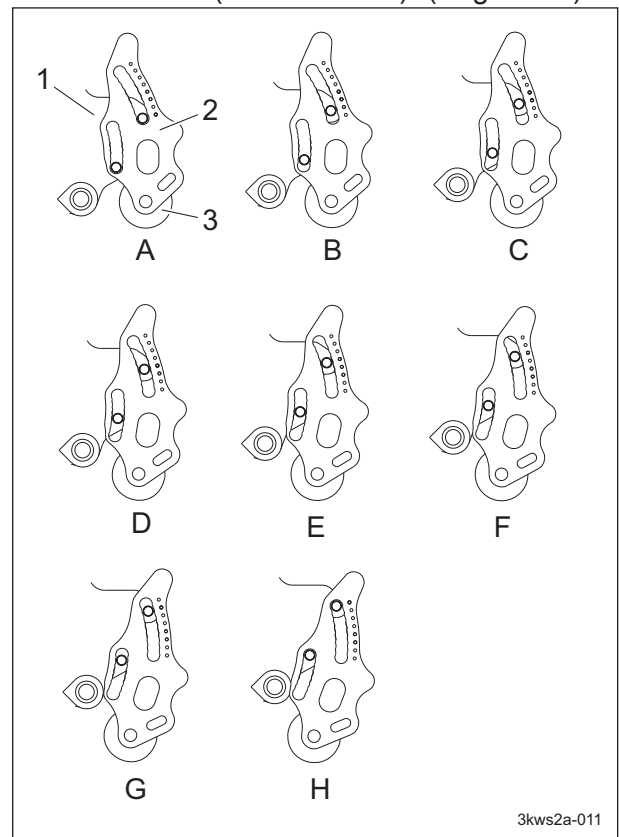

Adjustment of Rear Roller_003

1	Mower frame
2	Rear roller bracket
3	Rear roller
A	10.0 - 13.0 mm (0.394 - 0.512 in)
B	13.0 - 17.0 mm (0.512 - 0.669 in)
C	17.0 - 22.0 mm (0.669 - 0.866 in)
D	22.0 - 28.0 mm (0.866 - 1.102 in)
E	28.0 - 33.0 mm (1.102 - 1.299 in)
F	33.0 - 37.0 mm (1.299 - 1.457 in)
G	37.0 - 40.0 mm (1.457 - 1.575 in)
* H	40.0 - 43.0 mm (1.575 - 1.693 in)

* Not recommended by manufacturer.

Handling Instructions

Adjustment of Front Roller

1. Set the slide caliper to the required cutting height, adjust the neck position of the cutting height setting screw of the cutting height gauge and securely lock with a fly nut.
2. Loosen the nut which fixes the roller bracket of the front roller.
3. Apply the cutting height gauge to the front and rear rollers at each edge of left and right of the mower unit.

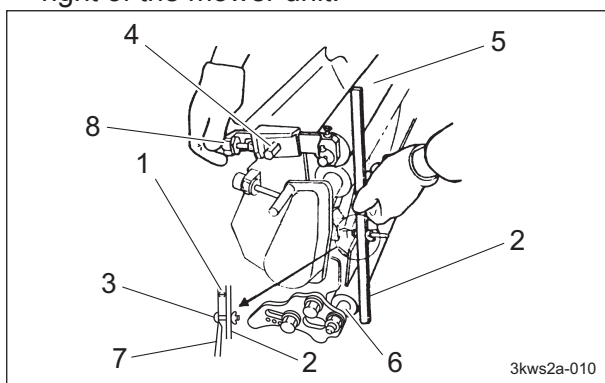

Adjustment of Front Roller_001

1	Cutting height
2	Cutting height gauge
3	Cutting height setting screw
4	Nut
5	Front roller
6	Rear roller
7	Bed knife (bottom blade)
8	Roller adjuster

4. Adjust the front roller up and down by the roller adjuster to determine the position of the front roller, in order not to have a gap with the neck position of the cutting height setting screw of the cutting height gauge, at the edge of the bed knife.

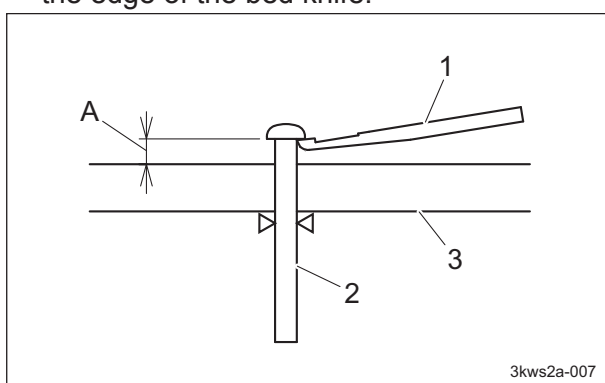

Adjustment of Front Roller_002

1	Bed knife (bottom blade)
2	Cutting height setting screw
3	Cutting height gauge
A	Cutting height

5. Repeat the same process at the opposite side for the adjustment of cutting height.
6. Tighten the nuts that secure the right and left roller brackets to secure them firmly.
7. Again, make sure that the cutting height is at the required position by applying the cutting height gauge to the front and rear rollers at each edge of right and left of the mower unit.

Adjustment of Groomer

Note:

Depending on the specifications, this function may not be available.

Important

- For adjustment, be sure to use the cutting height gauge so that the right and left sides can be parallel. Otherwise it may cause damage on the bearings.
- Set the grooming height more than 0.0 mm from the ground. Otherwise it may cause damage on the groomer shaft, bearings and gears etc.
- When using the grooming brush, set it to the same height as the cutting height. If it is set lower, it may wear easily.

1. Set the groomer setting screw of the cutting height gauge to the desired height.

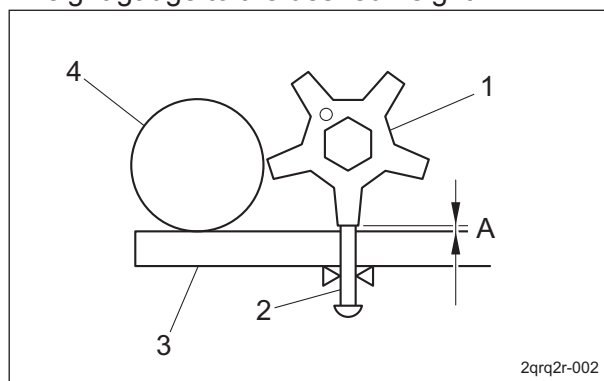

Adjustment of Groomer_001

Handling Instructions

1	Front groomer
2	Groomer setting screw
3	Cutting height gauge
4	Front roller
A	Operating height

2. Loosen the nuts fixing the right and left groomer adjustment bolts.

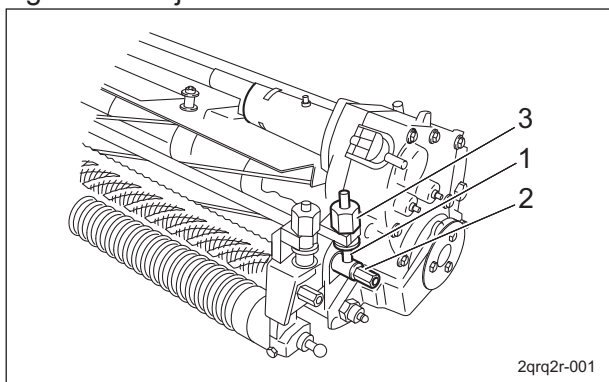

Adjustment of Groomer_002

1	Groomer adjustment bolt
2	Nut
3	Groomer adjuster

3. Adjust the groomer adjuster so that the groomer setting screw can contact with the cutting edge of the groomer.

- [1] Place the cutting height gauge set to the desired height on the ends of the front and rear rollers.
- [2] Adjust the groomer adjuster up and down so that the right and left sides can be parallel.
- [3] Adjust it at the other side in the same manner.
- [4] Tighten the nuts securely after adjustment.

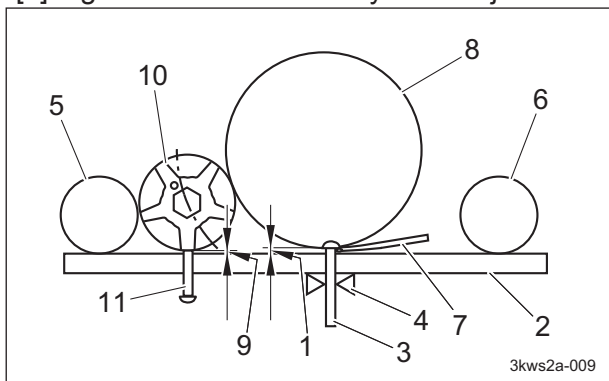

Adjustment of Groomer_003

1	Cutting height
2	Cutting height gauge
3	Cutting height setting screw
4	Nut
5	Front roller
6	Rear roller
7	Bed knife (bottom blade)
8	Reel cutter (cutting cylinder)
9	Grooming height
10	Front groomer
11	Groomer setting screw

Handling Instructions

Cutting Height and Blade Thickness of Bed Knife (Bottom Blade)

Important

The recommended minimum cutting heights are based on those of common greens. They may vary according to the green conditions and machine specifications. If the green undulation is hard, set it a little bit higher in order not to damage the green surface.

Blade thickness of the bed knife (bottom blade) roughly affects the recommended minimum cutting height like the figures below.

Thickness of blade (mm/inch)	Rough minimum cutting height (mm/inch)	Code	Part name	Remarks	
1.0/0.039	2.5/0.098	K2511000490	1 Bed knife (bottom blade) 22	Off set 2.5 mm	For green
		K2511000510	1 Bed knife (bottom blade) 22-44.5		
1.5/0.059	3.0/0.118	K2511000270	1.5 Bed knife (bottom blade) 55G	Off set 5 mm	For green
		K2510000320 (*)	1.5 Bed knife (bottom blade) 22		
		K2511000390	1.5 Bed knife (bottom blade) 55G-47		
		LM55GD-9085A0	1.5 Bed knife (bottom blade) 55G-44.5		
2.0/0.079	3.5/0.138	K2511000280	2 Bed knife (bottom blade) 55G	Off set 5 mm	For green
		K2511000350	2 Bed knife (bottom blade) 55G-47		
		K2511000450	2 Bed knife (bottom blade) 56G-44.5		
2.5/0.098	4.0/0.157	K2511000050	2.5 Bed knife (bottom blade) 55G	Off set 5 mm	For green
		K2511000240	2.5 Bed knife (bottom blade) 55G-47		
3.0/0.118	4.5/0.177	K2510000060	3 Bed knife (bottom blade) 62.5-559		For teeing ground/For field

* : STD for GB

Handling Instructions

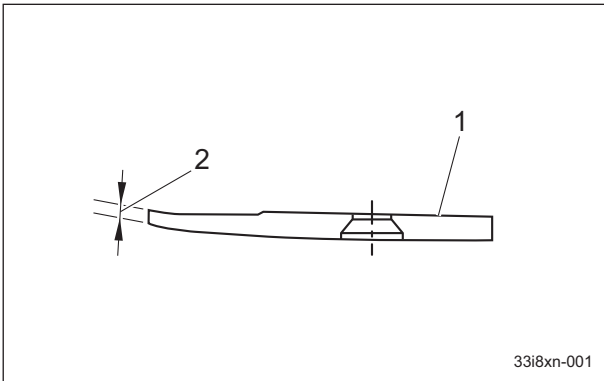

Cutting Height and Blade Thickness of Bed Knife (Bottom Blade)_001

1	Bed knife (bottom blade)
2	Thickness of blade

Adjustment of Cutter Adjustment Spring

If the diameter of the reel cutter (cutting cylinder) becomes smaller, adjust the cutter adjustment spring.

1. Adjust the blade engagement.
2. Loosen the pipe with cutter adjusting screw, and then adjust the length of the spring coil to approximately 26.0 mm (1.024 in).

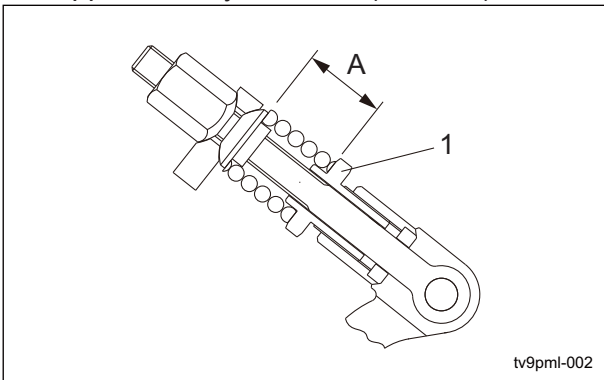

Adjustment of Cutter Adjustment Spring_001

1	Pipe with cutter adjusting screw
A	26.0 mm (1.024 in)

Procedure to Start/Stop Engine

Start/Stop of Engine

Procedure to Start Engine

Caution

Before starting the engine, make sure that there are no other people or obstacles around the machine.

Important

Starter operation must take 15 seconds or less.

If the engine does not start, stop using the battery for 30 to 60 seconds to avoid exhausting the battery.

1. Open the fuel cock.
The fuel cock is located beneath the fuel tank.

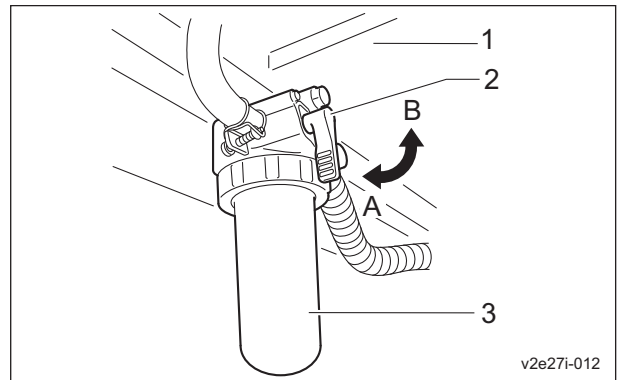

Procedure to Start Engine_001

1	Fuel tank
2	Fuel cock
3	Fuel filter
A	ON (open)
B	OFF (closed)

2. Sit on the seat.
3. Make sure that the parking brake is applied.
4. Set the reel rotation switch to the "Stop" position.

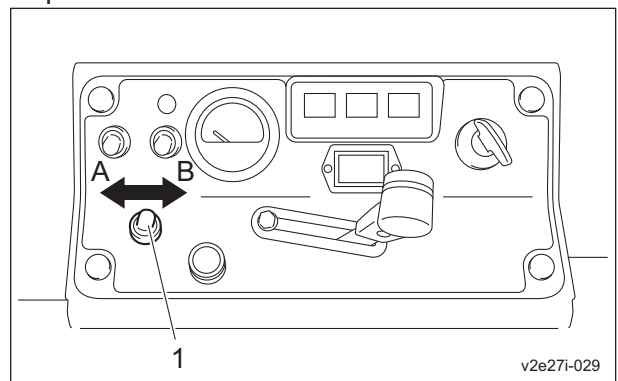

Procedure to Start Engine_002

1	Reel rotation switch
A	Rotate
B	Stop

5. Make sure that the traveling pedal is in the neutral position.

Handling Instructions

6. Shift the throttle lever halfway from the "Low speed" to the "High speed" position.

Important

The thermo-start lamp turns off at the specified time. However, the lamp turning off is not related to the glow plug generating heat. If the ignition key is left in the "GLOW" position after the lamp is turned off, the plug will still generate heat. The lamp will stay illuminated for five seconds.

7. Switch the ignition key to the "GLOW" position.

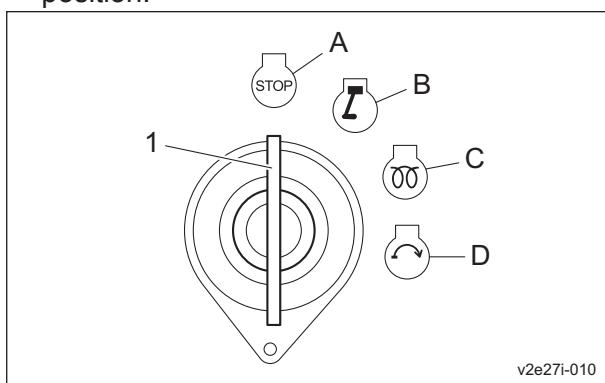

Procedure to Start Engine_003

1	Ignition key
A	OFF
B	ON
C	GLOW
D	START

8. Make sure that the glow plug is generating heat and the thermo-start lamp is turned on.

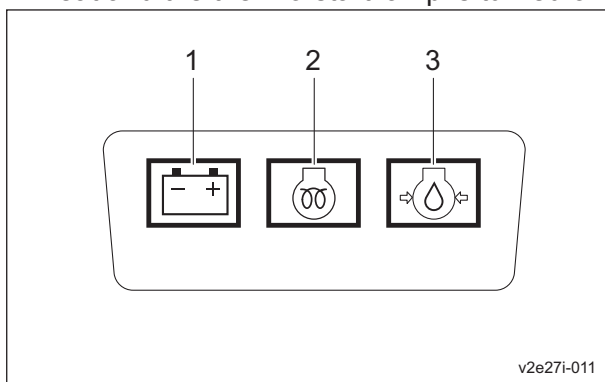

Procedure to Start Engine_004

1	Charge lamp
2	Thermo-start lamp
3	Oil pressure lamp

Important

Quickly returning the ignition key from the "START" position to the "ON" position may result in damage to the machine.

- After the thermo-start lamp turns off, immediately set the ignition key to the "START" position.
- When the starter starts rotating and the engine starts, slowly return the ignition key to the "ON" position.
- Make sure that the charge lamp and engine oil pressure lamp turn off. If they do not turn off, stop the engine and inspect the machine.
- Shift the throttle lever to the "Low speed" position, and then warm up the engine for 1-2 minutes.
- Gradually move the throttle lever to the "High speed" position.

Procedure to Stop Engine

- Set the traveling pedal to the neutral position.
- Apply the parking brake.
- Set the reel rotation switch to the "Stop" position.
- Shift the throttle lever to the "Low speed" position, and then warm up the engine for 1-2 minutes.
- Switch the ignition key to the "OFF" position.
- Make sure that the engine has stopped.
- Remove the ignition key.
- Leave the driver's seat.
- Close the fuel cock.
The fuel cock is located beneath the fuel tank.

Handling Instructions

Safety Mechanisms

This machine features a safety device for starting/stopping the engine.

- As for starting the engine, the safety device prevents the engine from starting unless it meets each of the following four conditions.
 - An operator is sitting on the seat.
 - The parking brake is applied.
 - The reel rotation switch is set to the "Stop" position.
 - The traveling pedal is set to the neutral position.
- The safety device will be activated and will stop the engine under any of the following conditions:
 - The operator leaves the seat without applying the parking brake.
 - The operator leaves the seat while the reel cutter (cutting cylinder) is positively rotating.
 - The traveling pedal is operated after the parking brake is applied and the operator leaves the seat.

Warning Mechanisms

This machine features warning mechanisms on overheating, hydraulic oil level and preventing traveling while the parking brake is applied.

- If water temperature inside the engine exceeds 105 degrees Celsius, a buzzer will sound. (intermittent tone)
- If the oil level in the hydraulic tank declines from the specified level by approximately 1.2 dm³ (1.2 L), a buzzer will sound. (intermittent tone)
- If the traveling pedal is depressed while the parking brake is applied, a buzzer will sound. (intermittent tone)

Operation Method

Cautions for when You Leave The Machine

⚠ Caution

If the brakes are not sufficiently effective, use the wheel stoppers to secure the machine.

⚠ Caution

Never park the machine on a slope.

Positions of Operation Decals

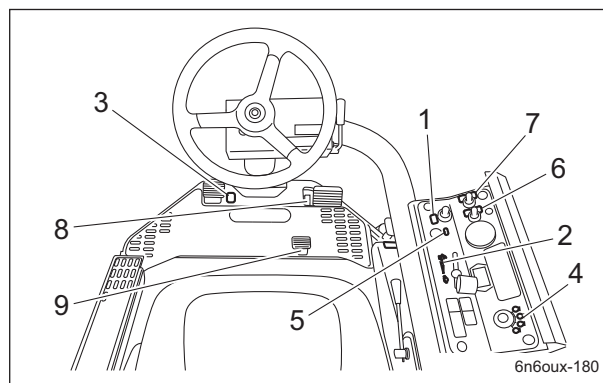

Positions of Operation Decals_001

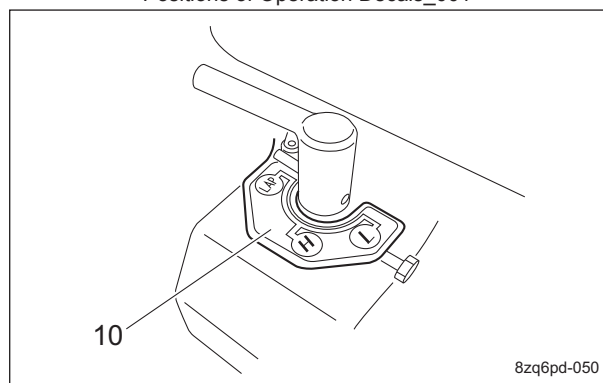

Positions of Operation Decals_002

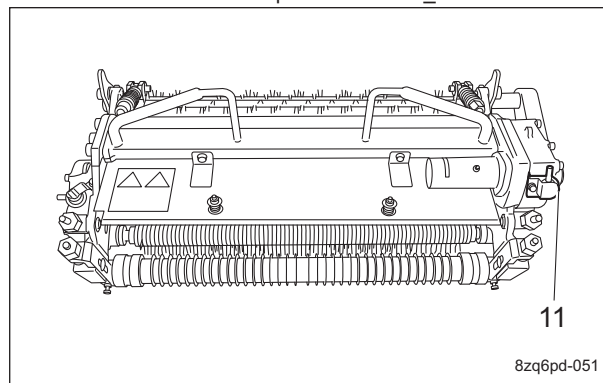

Positions of Operation Decals_003

Handling Instructions

1	Reel rotation/stop mark
2	Engine rotation mark
3	Mower unit Up/Down decal
4	Key switch mark
5	Mower unit up-switch (with reel excess discharge system) mark
6	2WD/3WD changeover decal
7	Light switch decal
8	FORWARD Decal
9	BACKWARD Decal
10	Position decal
11	Mower unit reel rotation changeover decal

1	Low speed
2	High speed

Mower Unit Up/Down Decal

K4203001520

Decal, lifting units

This indicates up-down of the mower unit.

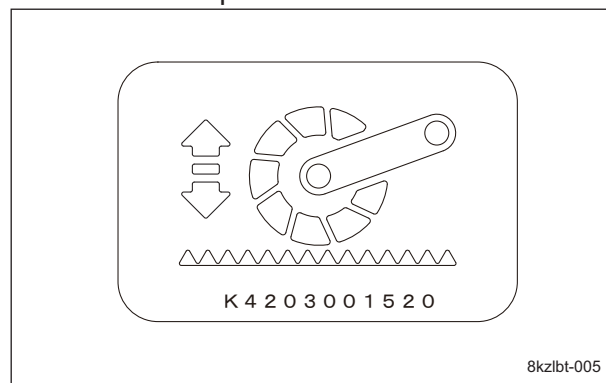

Mower Unit Up/Down Decal_001

Description of Operation Decals

Reel Rotation/Stop Mark

Reel rotation/stop mark

It illustrates Rotation/Stop of the reel cutter (cutting cylinder).

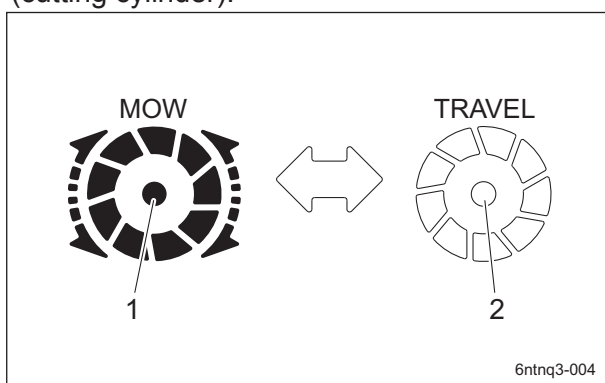

Reel Rotation/Stop Mark_001

1	Rotation
2	Stop

Key Switch Decal

Key switch decal

This indicates the key switch positions.

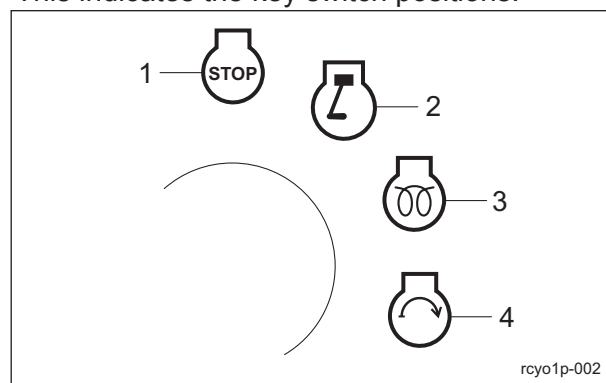

Key Switch Decal_001

1	OFF
2	ON
3	GLOW
4	START

Engine Rotation Mark

Engine rotation mark

This indicates low/high speed of engine rotation.

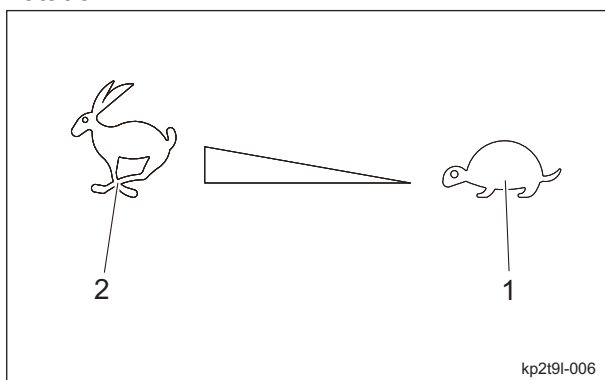

Engine Rotation Mark_001

Handling Instructions

Mower Unit Up-Switch (with Reel Excess Discharge System) Mark

Mower unit up-switch (with reel excess discharge system) mark
 This indicates mower unit up-switch and reel excess discharge system.

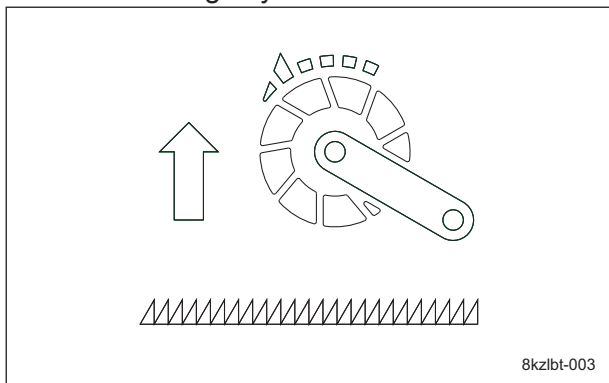

Mower Unit Up-Switch (with Reel Excess Discharge System) Mark_001

Light Switch Mark

Note:
 Depending on the specifications, this function may not be available.
 K4203001610
 DECAL, LIGHT SWITCH
 It illustrates ON/OFF of the light.

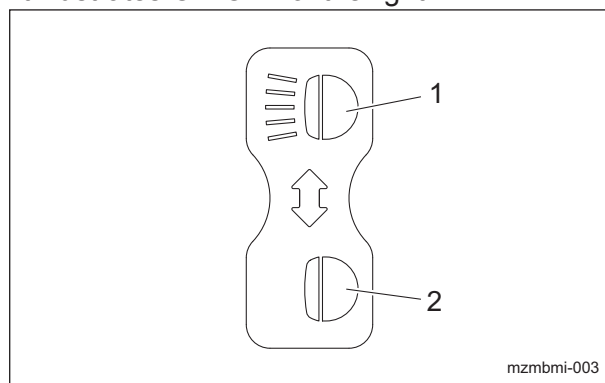

Light Switch Mark_001

1	ON
2	OFF

2WD/3WD Changeover Decal

Note:
 Depending on the specifications, this function may not be available.
 K4203001620
 Decal, shifting 2WD/3WD
 This indicates 2WD/3WD changeover.

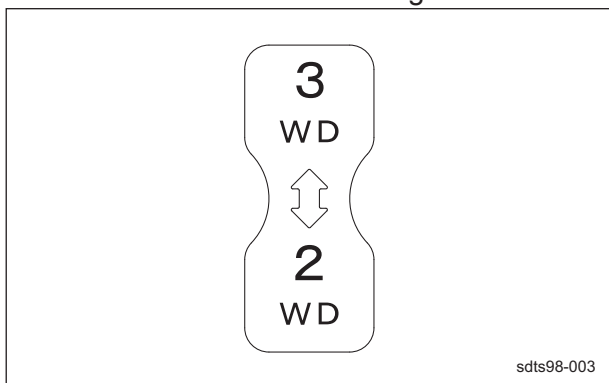

2WD/3WD Changeover Decal_001

FORWARD Decal

K4203001430
 Decal, FORWARD
 This indicates forward travel.



FORWARD Decal_001

Handling Instructions

BACKWARD Decal

K4203001440
Decal, BACKWARD
This indicates backward travel.



BACKWARD Decal_001

Position Decal

LM315GC1418Z0
Decal, position
This indicates changeover of High/Low speed of reel cutter rotation and back lapping rotation.

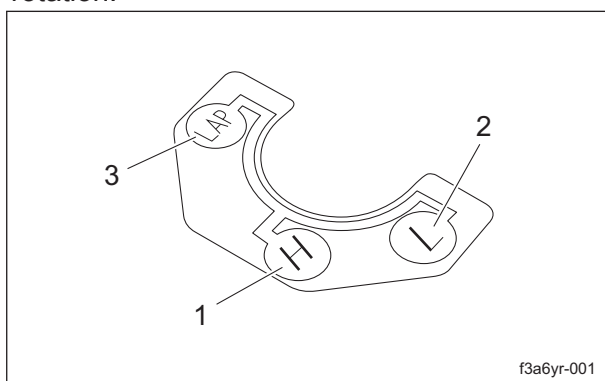

Position Decal_001

1	High speed
2	Low speed
3	Back lapping

Mower Unit Reel Rotation Changeover Decal

K4203001550
Sticker, rotating direction
This indicates changeover of normal rotation, neutral and reverse rotation of mower unit reel cutter.

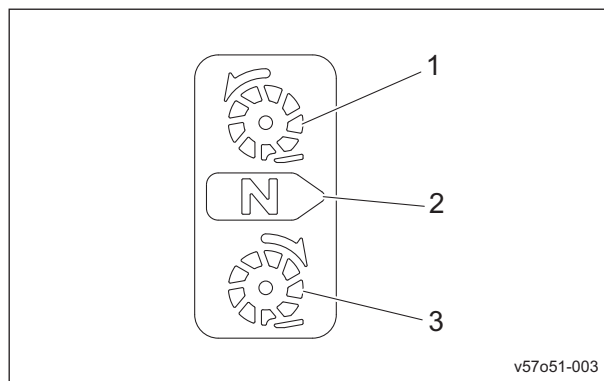

Mower Unit Reel Rotation Changeover Decal_001

1	Normal rotation (cutting rotation)
2	Neutral
3	Reverse rotation (back lapping rotation)

Light Switch

Note:
Depending on the specifications, this function may not be available.
The light switch is located in the operation panel.
Flip the switch up to turn the light on, and down to turn the light off.

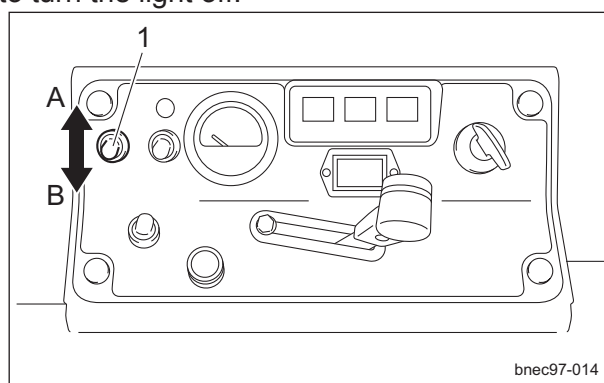

Light Switch_001

1	Light switch
A	ON
B	OFF

Handling Instructions

Throttle Lever

The throttle lever is located in the operation panel and enables you to adjust the engine rpm.

Move the throttle lever toward the "High speed" to increase the engine rpm, and toward the "Low speed" to reduce the rpm.

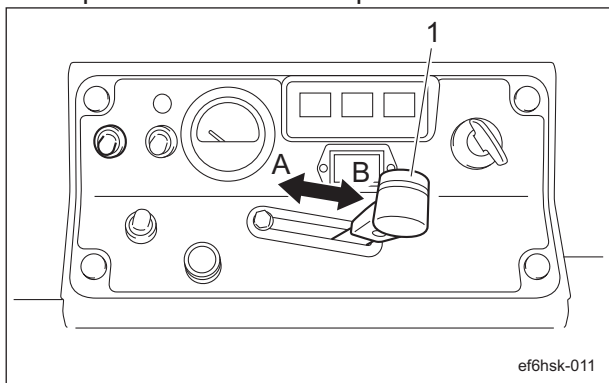

Throttle Lever_001

1	Throttle lever
A	High speed
B	Low speed

Mower Pedal

Caution

Do not keep depressing the mower pedal after an operation. It may cause malfunction.

Important

Even if the reel rotation switch is set to the "Rotation" position, when the mower units are raised, the reel cutters (cutting cylinders) stop rotating.

Important

Operation of the mower pedal cannot raise the mower units to the highest position. When traveling, keep pressing the up switch to raise the mower units to the highest position.

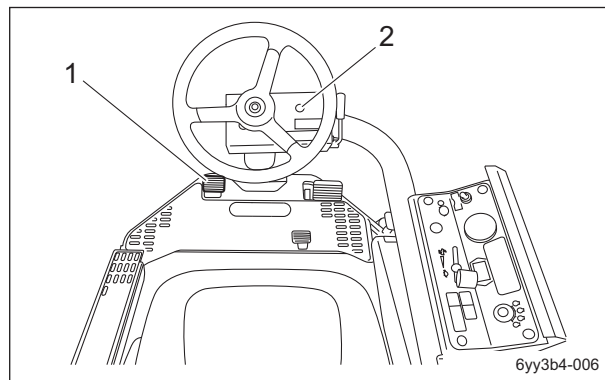

Mower Pedal_001

1	Mower pedal
2	Green LED

The mower pedal is located on the left of the foot area in front of the driver's seat. Depressing the pedal switches the mower units between the up and down positions. When it is switched to the down position, the green LED on the steering column lights up. The Up/Down speed of the mower unit is affected by the engine rotation speed. When the engine rotation is at low speed, the Up/Down speed is at low as well.

Handling Instructions

Joystick

Note:

Depending on the specifications, this function may not be available.

Important

Even if the reel rotation switch is set to the "Rotation" position, when the mower units are raised, the reel cutters (cutting cylinders) stop rotating.

Important

Operation of the joystick cannot raise the mower units to the highest position. When traveling, keep pressing the up switch to raise the mower units to the highest position.

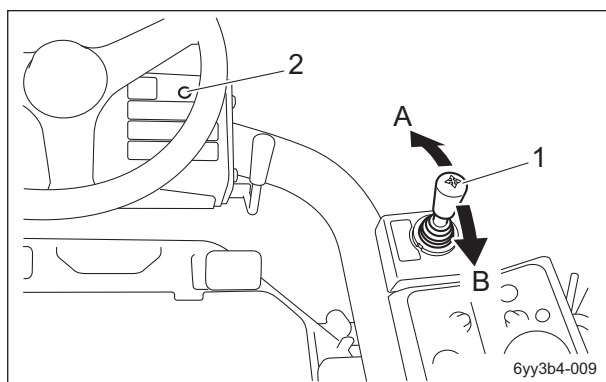

Joystick_001

1	Joystick
2	Green LED lamp
A	Down
B	Up

Tilting the joystick back and forth switches the mower units between the up and down positions.

Only while the joystick tilted to the "Down" position, the green LED on the steering column lights up.

The Up/Down speed of the mower unit is affected by the engine rotation speed. When the engine rotation is at low speed, the Up/Down speed is at low as well.

Mower Unit Up Switch

Up Switch (with Reel Excess Discharge System)

Warning

The reel cutter rotates while holding down the up switch when the reel rotation switch is set to the "Rotation" position.

Set the reel rotation switch to the "Stop" position except during mowing or backlapping and using reel excess discharge system.

Warning

The reel cutter rotates when using reel excess discharge system.

Keep hands and feet away from moving parts.

Caution

Before using reel excess discharge system, make sure that there are no people around the machine.

Important

Do not press the up switch when the mower unit is at lowered position. Otherwise, the harness may get damaged.

Important

The reel cutter keeps rotating even if the mower unit raised to the highest position while holding down the up-switch.

Up Switch

The up switch is located in the operation panel.

If the height of the mower unit is not sufficient for traveling etc, set the reel rotation switch to the "Stop" position and keep pressing the up switch to operate the magnetic valve to raise the mower unit to the highest position.

Handling Instructions

- Reel excess discharge system
 Reel excess discharge system is the function to remove clippings inside the reel cutter by rotating the reel cutter with the up switch on the condition that the mower unit raised and the reel rotation switch set to the "Rotation" position.
 With this function, falling of lumps of clippings can be prevented during mowing operation and the time of washing the vehicle can be shortened.

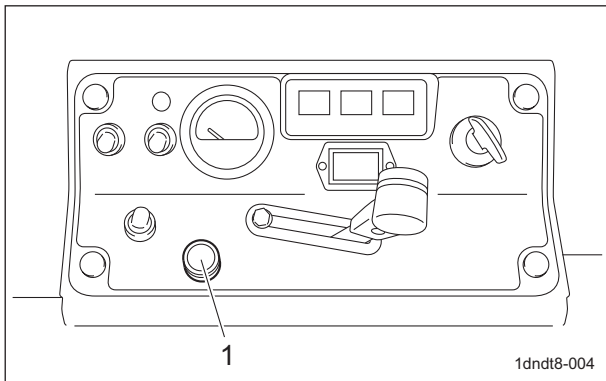

Up Switch (with Reel Excess Discharge System)_001

1	Up Switch(with reel excess discharge system)
---	--

Note:
 Depending on the specifications, this function may not be available.
 The 2WD/3WD selector switch is located in the operation panel.
 Flip the switch to the "2WD" position to select 2WD mode, and flip it to the "3WD" position to select 3WD mode.
 When the traveling mode is switched to 3WD, the red LED above the 2WD/3WD selector switch lights up.

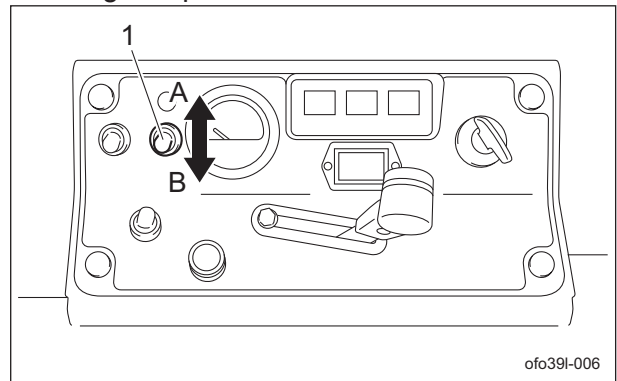

2WD/3WD Selector Switch_001

1	2WD/3WD selector switch
A	3WD
B	2WD

2WD/3WD Selector Switch

Caution

When switching between 2WD and 3WD operation, make sure to stop the machine completely.

Caution

In case of 2WD/3WD model, travel in 2WD mode since it is dangerous to travel on steep downward slopes, wet road surface or downward slopes of wet lawn in 3WD mode. Rear tire going into a skid may cause loss of traveling control.

Important

When the reel rotation switch is set to the "Rotation" position, regardless of the position of the 2WD/3WD selector switch, 3WD is selected.
 When the traveling mode is switched to 3WD, the red LED in front of the 2WD/3WD selector switch lights up.

Handling Instructions

Reel Rotation Switch

Warning

The reel cutter rotates while holding down the up switch when the reel rotation switch is set to the "Rotation" position. Set the reel rotation switch to the "Stop" position except during mowing or backlapping and using reel excess discharge system.

Caution

In case of 2WD/3WD model, travel in 2WD mode since it is dangerous to travel on steep downward slopes, wet road surface or downward slopes of wet lawn in 3WD mode. Rear tire going into a skid may cause loss of traveling control.

Important

In case of 2WD/3WD model, whenever the reel rotation switch is set to the "Rotation" position, the drive mode is put into 3WD regardless of the position of the 2WD/3WD selector switch.

The reel rotation switch is located in the operation panel. Setting the switch to the "Rotation" position rotates the reel, and to the "Stop" position stops the reel.

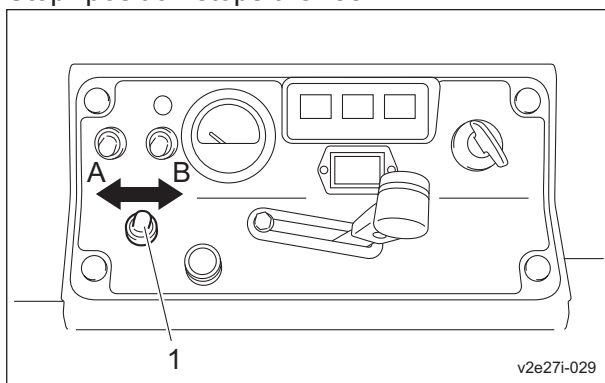

Reel Rotation Switch_001

1	Reel rotation switch
A	Rotate
B	Stop

When the reel rotation switch is set to the "Rotation" position, the reel cutters (cutting cylinders) will rotate or stop in sync with the up and down motion of the mower units. When the mower units are lowered, the reel cutters (cutting cylinders) rotate, and when the mower units are raised, they stop.

1. When the mower units are lowered, the sensor activates the electromagnetic clutch, and the reel cutters (cutting cylinders) start rotating by means of the flexible wire.
2. When the mower units are raised, even if the reel rotation switch is set to the "Rotation" position, the sensor does not activate the electromagnetic clutch, and the reel cutters (cutting cylinders) do not rotate.

Reel Reverse Lever

Important

Operate the reel reverse lever while the rotation of the reel cutter (cutting cylinder) is stopped, and adjust it to the position suitable for your work.

The reel reverse lever is located at the upper part of the gear case of the mower unit. If you set the lever to Normal, it starts cutting rotation, set to Reverse for back lapping rotation and Neutral for free rotation.

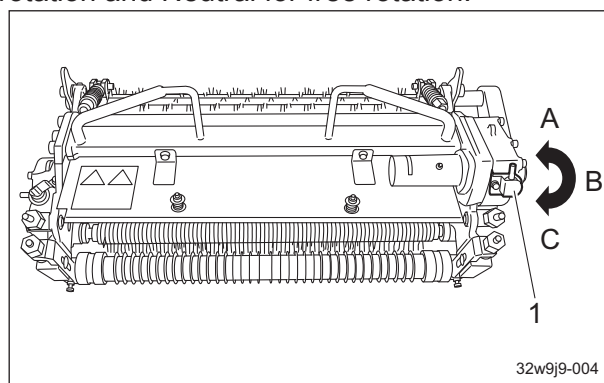

Reel Reverse Lever_001

1	Reel reverse lever
A	Normal rotation
B	Neutral
C	Reverse rotation

Handling Instructions

Transmission Selector Lever

Caution

Be sure to stop the engine before and during shifting the transmission selector. Otherwise, your hands may get caught in the belt.

Caution

The transmission selector lever should be operated while the engine rotation is stopped, and adjusted to the position suitable for your work.

Important

For the LM315GC (for fields), normally cut with the lever set to the "Low speed" position.

The transmission selector lever is located at the upper part of the transmission, behind the driver's seat. When the lever is shifted to the "High speed" position the reel cutters (cutting cylinders) rotate fast; on "Low speed" they rotate slowly; on "Back lapping" they rotate more slowly, at a suitable speed for back lapping.

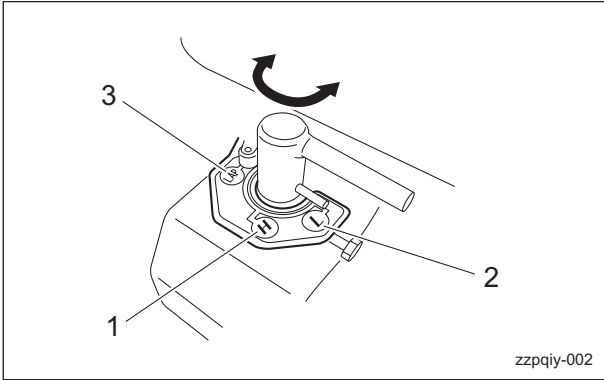

Transmission Selector Lever_001

1	High speed
2	Low speed
3	Back lapping

1. High speed (H)

The reel cutters (cutting cylinders) rotate faster, and the clip pitch (cutting interval) becomes shorter.

This is suitable for the work at a good turf condition.

2. Low speed (L)

The reel cutter (cutting cylinder) rotates slower compared to when it is at the "High speed" position and the clip pitch becomes longer.

This is suitable for the work at the turf condition not so good.

3. Back lapping (LAP)

The reel cutter (cutting cylinder) rotates in a speed suitable for the back lapping and its maintainability increases. (The rotation direction is not changed, so use the reel reverse lever of the mower unit to reverse the rotation).

Traveling Pedal

Caution

When the machine is traveling at a high speed, it will not stop immediately after you take your foot off the traveling pedal.

Important

When the reel rotation switch is turned to the "Rotation" position the working speed is limited by the pedal stopper.

The traveling pedals are located in the right foot area and control forward and reverse operation of the machine.

When the forward pedal (front side) is depressed, the machine travels forward. When the reverse pedal (rear side) is depressed, the machine travels backward.

The speed changes in accordance with how much the pedal is depressed.

When you take your foot off the pedal, the machine stops automatically.

Handling Instructions

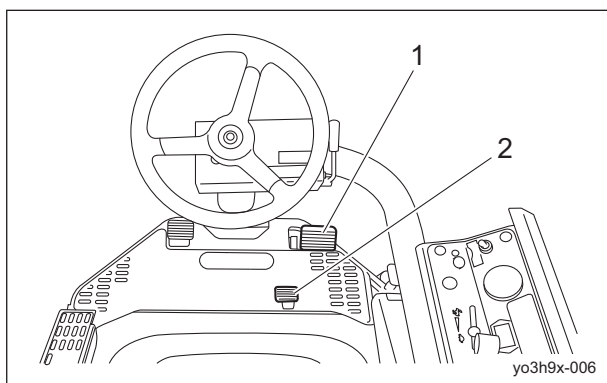

Traveling Pedal_001

1	Forward pedal
2	Reverse pedal

Parking Brake Lever

Caution

Never park the machine on a slope.

Important

Be sure to release the parking brake before driving. Otherwise, it can cause the malfunction of the brake or hydraulic system.

The parking brake lever is located at the left of the driver's seat.

To park the machine, pull the parking brake lever completely.

To release the parking brake, press the push button while lowering the parking brake lever all the way to its resting position.

If the traveling pedal is depressed while the parking brake is applied, a buzzer will sound. (intermittent tone)

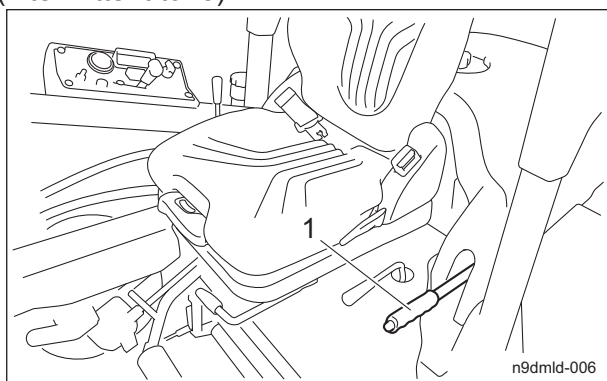

Parking Brake Lever_001

1	Parking brake lever
---	---------------------

Hood

Caution

Do not open the hood in strong winds.

Caution

Be careful not to pinch your fingers when you open or close the hood.

1. Remove the bolt.
2. Lift up the hood.
3. Make sure that the hood will not close, and then remove your hands.

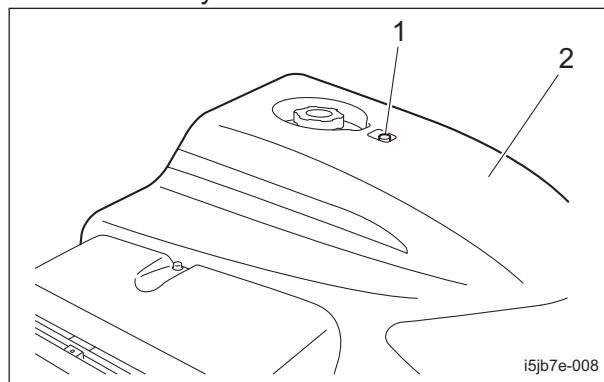

Hood_001

1	Bolt
2	Hood

4. When closing the hood, do the operation slowly.
5. Press the hood lightly and lock it with the bolt.

Handling Instructions

Underseat Cover

⚠ Caution

Be careful not to pinch your fingers when you open or close the underseat cover.

1. Remove the grass catcher located at the center.
"Removing Grass Catcher" (Page 4-42)
2. Adjust the steering wheel arm to the lowest position.
"Adjustment of Steering Wheel" (Page 4-17)
3. Slide the seat forward and rotate the lock lever 90 degrees anticlockwise.

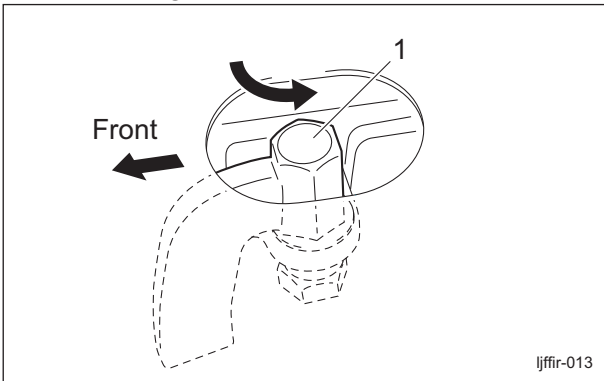

Underseat Cover_001

1	Lock lever
---	------------

4. Pull up the forward tilt angle adjustment lever and lift up the underseat cover together with the seat.

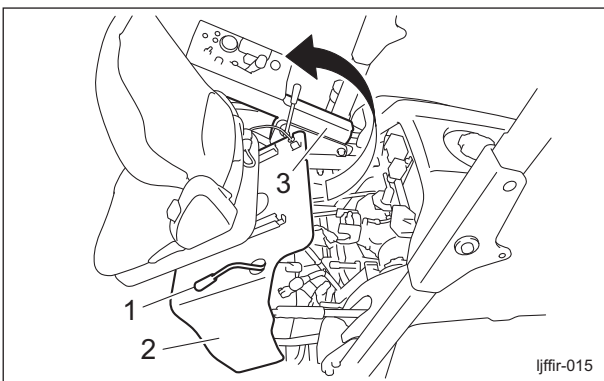

Underseat Cover_002

1	Forward tilt angle adjustment lever
2	Underseat cover
3	Steering wheel arm

5. When closing the underseat cover, do it slowly and be sure to use the forward tilt angle adjustment lever to fix it securely.

6. Rotate the lock lever 90 degrees clockwise to fix the underseat cover.

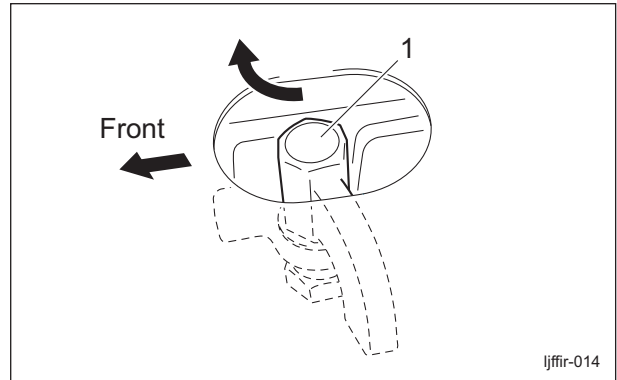

Underseat Cover_003

1	Lock lever
---	------------

Broom Holder

Note:

Depending on the specifications, this function may not be available.

Broom can be stored in this holder for transport.

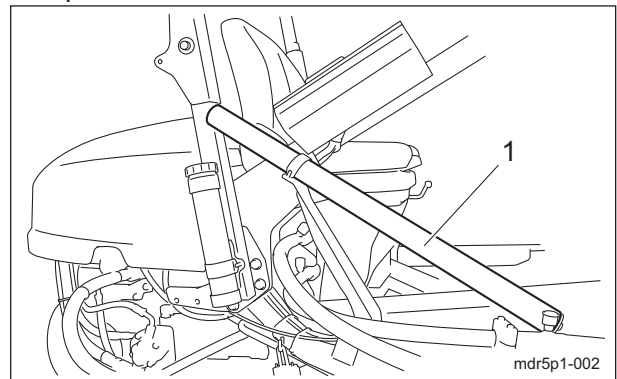

Broom Holder_001

1	Broom holder
---	--------------

Handling Instructions

Swisher Holder

Note:
Depending on the specifications, this function may not be available.
Swisher pole can be stored in this holder for transport.

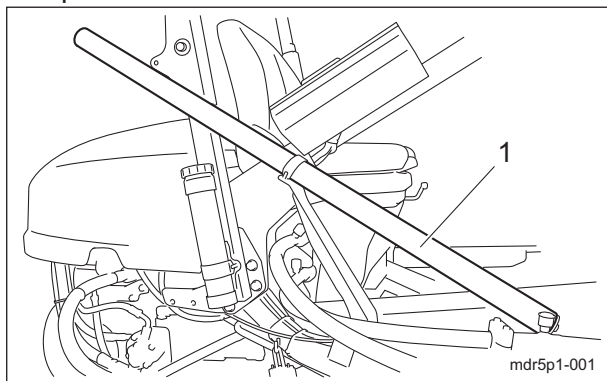

Swisher Holder_001

1	Swisher holder
---	----------------

Instruments

Instruments on The Operation Panel

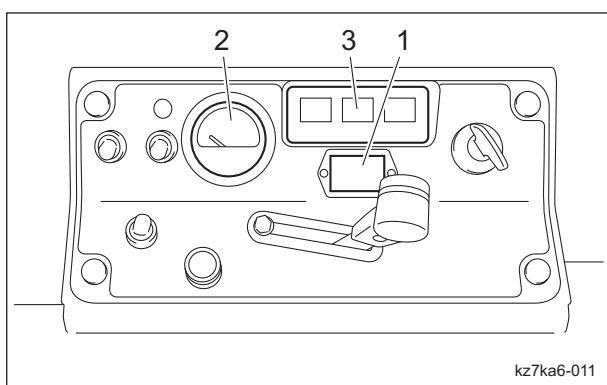

Instruments on The Operation Panel_001

1	Hour meter
2	Water temperature gauge
3	Pilot lamp

Hour Meter

The hour meter is located in the operation panel, and indicates the accumulated operation time of the engine.
The number in black figures on a white background is incremented every six minutes.
The number in white figures on a black background is incremented every hour.
1/10 wheel ... black figures on a white background
Hour wheel ... white figures on a black background

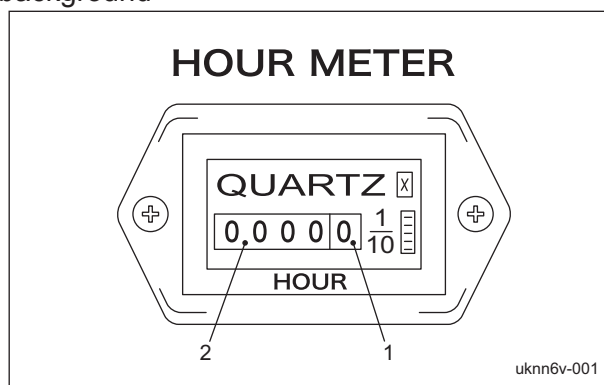

Hour Meter_001

1	1/10 wheel
2	Hour wheel

Handling Instructions

Water Temperature Gauge

The water temperature gauge is located in the operation panel.

This instrument indicates the water temperature inside the engine.

If the water temperature gauge indicates a level close to "H" during operation, the machine is overheated.

Remove the load from the engine, idle the machine for five minutes, stop the engine, and then inspect the machine and perform any necessary maintenance.

If the water temperature exceeds 105 degrees Celsius, a buzzer will sound. (Intermittent tone)

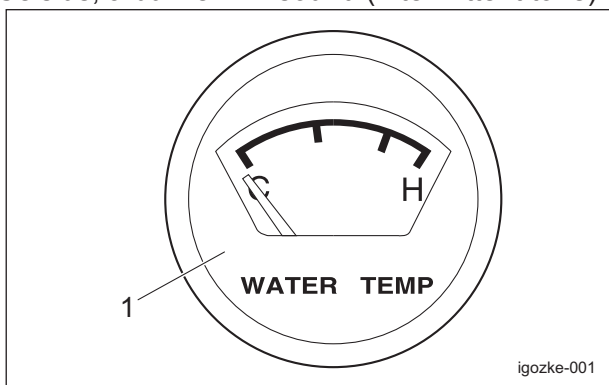

Water Temperature Gauge_001

1	Water temperature gauge
---	-------------------------

Pilot Lamps

Charge Lamp

The charge lamp is the left pilot lamp located in the operation panel.

It turns on when the ignition key is set to the "ON" position before the engine starts. It turns off when the engine starts and the alternator starts operating properly.

If this lamp illuminates while you are operating the machine, stop the engine immediately, and then inspect the machine and perform any necessary maintenance.

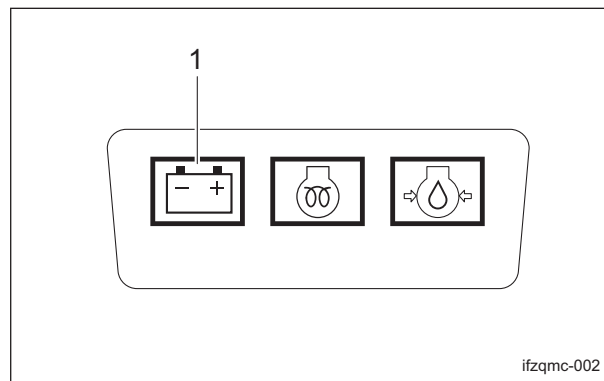

Charge Lamp_001

1	Charge lamp
---	-------------

Thermo-Start Lamp

The thermo-start lamp is the middle pilot lamp located in the operation panel.

When the ignition key is set to the "GLOW" position, it illuminates as the glow plug generates heat.

Illumination of the thermo-start lamp is controlled by the glow lamp timer, and the lamp is turned off after a specified amount of time passes.

The duration of illumination indicates an approximate period of time required for warm-up, and has been fixed at five seconds.

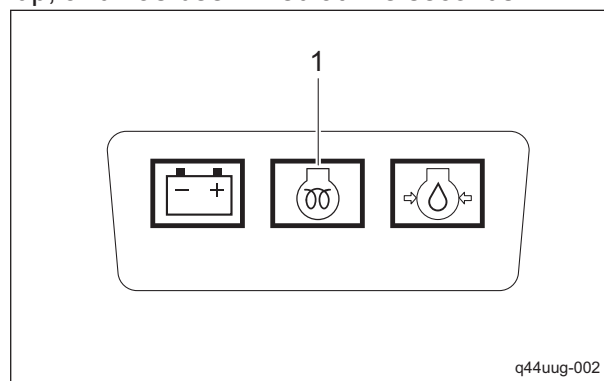

Thermo-Start Lamp_001

1	Thermo-start lamp
---	-------------------

Oil Pressure Lamp

The oil pressure lamp is the right pilot lamp located in the operation panel. It turns on when the ignition key is set to the "ON" position before the engine starts. It turns off when the engine starts and engine oil pressure is generated properly. If this lamp illuminates while you are operating the machine, stop the engine immediately, and then inspect the machine and perform any necessary maintenance.

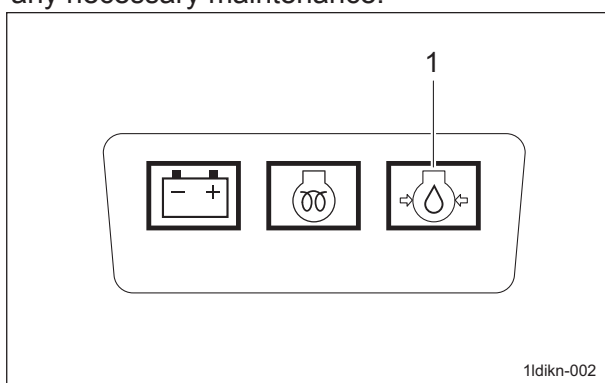

Oil Pressure Lamp_001

1	Oil pressure lamp
---	-------------------

Fuel Gauge

The fuel gauge is located on the fuel tank. This instrument indicates the quantity of fuel inside the fuel tank.

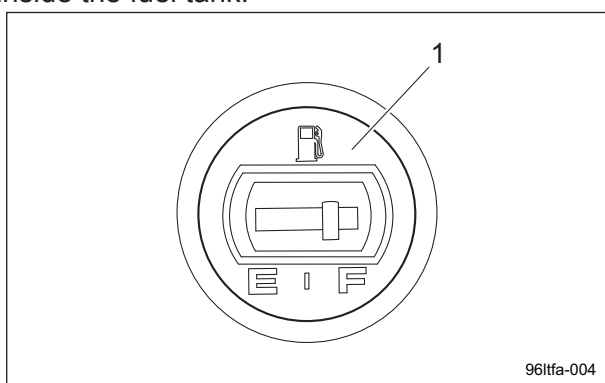

Fuel Gauge_001

1	Fuel gauge
---	------------

Travel of Machine

Moving The Machine

Warning

Set the reel rotation switch to the "Stop" position except during mowing or backlapping and using reel excess discharge system.

Caution

Under any circumstances drive the machine at such a speed that you can stop it immediately for emergencies.

Caution

In case of 2WD/3WD model, travel in 2WD mode since it is dangerous to travel on steep downward slopes, wet road surface or downward slopes of wet lawn in 3WD mode. Rear tire going into a skid may cause loss of traveling control.

Important

In case of 2WD/3WD model, whenever the reel rotation switch is set to the "Rotation" position, the drive mode is put into 3WD regardless of the position of the 2WD/3WD selector switch.

1. Start the engine.
"Procedure to Start Engine" (Page 4-24)
2. Raise all mower units.
3. While pressing the push button, release the parking brake lever.
4. Slowly depress the traveling pedal.
5. The machine can start traveling.

Handling Instructions

Towing The Machine

If the machine does not travel due to engine trouble, etc., you can move it in the following ways:

- Pushing by hand
- Towing (See the following instruction.)

Caution

Do not tow on slopes.

Caution

Tow the machine at a low speed while paying close attention.

Important

Do not touch the unload valve except when towing the machine.

Important

Before restarting the engine, be sure to close the unload valve.

1. Stop the engine.
"Procedure to Stop Engine" (Page 4-25)
2. Apply the parking brake and chock the wheels.
3. The unload valve is located at the lower right of the frame.
While pressing the unload valve, rotate it 90 degrees (vertically) to open.

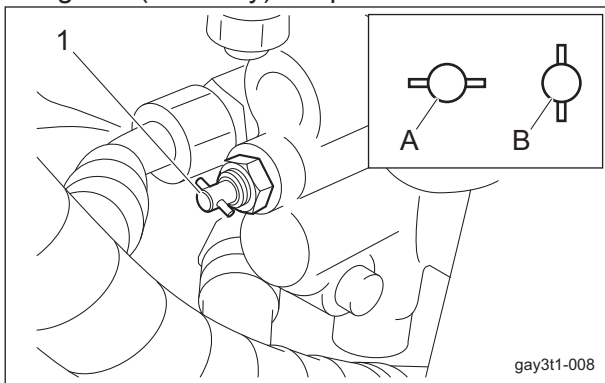

Towing The Machine_001

1	Unload valve
A	Onload
B	Unload

4. While pressing the push button, release the parking brake lever and remove the wheel stopper.

5. Tow the machine slowly.

Cutting Work

Cutting Work

Warning

Do NOT start to move or stop the machine abruptly.
To do so is very dangerous. In addition, it may damage the hydraulic system or result in oil leakage.

Warning

Set the reel rotation switch to the "Stop" position except during mowing or backlapping and using reel excess discharge system.

Caution

In case of 2WD/3WD model, travel in 2WD mode since it is dangerous to travel on steep downward slopes, wet road surface or downward slopes of wet lawn in 3WD mode. Rear tire going into a skid may cause loss of traveling control.

Caution

Be sure to install the grass catchers. Otherwise, flying objects from the mower units may hit your feet.

Important

In case of 2WD/3WD model, whenever the reel rotation switch is set to the "Rotation" position, the drive mode is put into 3WD regardless of the position of the 2WD/3WD selector switch.

1. Install the grass catchers.
2. Start the engine.
"Procedure to Start Engine" (Page 4-24)
3. Raise all mower units.
4. While pressing the push button, release the parking brake lever.
5. Shift the throttle lever to the "High speed" position to run the engine at the maximum speed.
6. Set the reel rotation switch to the "Rotation" position.

Handling Instructions

7. Start the work following the procedure below.

[1] Depress the traveling pedal.

[2] Depress the mower pedal when the mower unit reaches the collar of the green.

[3] Lower the mower units to start rotating the reel cutters (cutting cylinders).

Note:

During the work, the reel cutters (cutting cylinders) will rotate or stop in sync with the up and down motion of the mower units.

8. Set the reel rotation switch to the "Stop" position after the operation completed.

Reel Excess Discharge System

Warning

The reel cutter rotates while holding down the up switch when the reel rotation switch is set to the "Rotation" position.

Set the reel rotation switch to the "Stop" position except during mowing or backlapping and using reel excess discharge system.

Warning

The reel cutter rotates when using reel excess discharge system.

Keep hands and feet away from moving parts.

Caution

Before using reel excess discharge system, make sure that there are no people around the machine.

Important

Do not press the up switch when the mower unit is at lowered position.

Otherwise, the harness may get damaged.

Important

The reel cutter keeps rotating even if the mower unit raised to the highest position while holding down the up-switch.

· Preventing lumps of clippings from falling onto the green.

Use reel excess discharge system so that the clippings inside the reel cutter can be removed during mowing operation or when discarding clippings.

1. Stop the engine.

2. Brush the clippings accumulated on the bracket.

At the time the clippings comes inside of the reel cutter.

3. Install the grass catchers.

4. Sit on the seat.

5. Start the engine.

6. Raise all mower units.

7. Set the reel rotation switch to the "Rotation" position.

8. Hold down the up switch for about a second.

While holding down the up switch, the reel cutter rotates while the mower unit rising and the clippings inside the reel cutter are removed.

9. Set the reel rotation switch to the "Stop" position after the operation completed.

10. Stop the engine.

· Vehicle wash

When washing the vehicle after mowing operation, the clippings can be removed with the reel excess discharge system.

1. Stop the engine.

2. Set the transmission shift lever to the "LAP" position.

3. Sit on the seat.

4. Start the engine.

5. Raise all mower units.

6. Set the reel rotation switch to the "Rotation" position.

7. Stand on the right side of the machine and hold down the up switch for about 2 to 3 seconds.

While holding down the up switch, the reel cutter rotates while the mower unit rising and the clippings inside the reel cutter are removed.

8. Set the reel rotation switch to the "Stop" position after the operation completed.

9. Stop the engine.

Handling Instructions

Removing Grass Catcher

1. To discard the collected grasses, set the reel rotation switch to the "Stop" position.
2. Lower the mower unit.
3. Apply the parking brake.
4. Stop the engine.
5. Lift up the grass catcher and remove it.

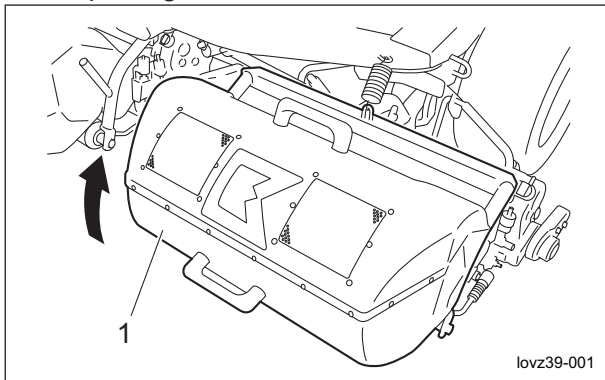

Removing Grass Catcher_001

1	Grass catcher
---	---------------

Transporting

Transporting Procedure

When loading the machine into a trailer or a truck to transport it, drive the machine forward.
When unloading, drive the machine in reverse.

Storage

Before Long-Term Storage

- Remove dirt, grass clippings, debris, oil stains etc. completely.
- Supply oil and apply grease to appropriate parts.
- Remove the negative terminal of the battery.

Maintenance Precautions	Page 5-2
Maintenance Schedule	Page 5-2
Adjusted Value	Page 5-8
Jacking Up The Machine	Page 5-9
About Jacking Up The Machine	Page 5-9
Jack-Up Points	Page 5-9
Greasing	Page 5-10
About Greasing	Page 5-10
Greasing Points	Page 5-10
Lubrication	Page 5-14
About Lubrication	Page 5-14
Lubricating Points	Page 5-14
Maintenance Work	Page 5-15
Back Lapping	Page 5-15
Adjusting CAM	Page 5-17
Sharpening of Reel Cutter (Cutting Cylinder)	Page 5-17
Replacement of Reel Cutter (Cutting Cylinder)	Page 5-19
Replacement of Bed Knife (Bottom Blade)	Page 5-20
Removing/Installing Tires	Page 5-21
Adjustment of Belt Tension	Page 5-22
Adjustment of Parking Brake	Page 5-24
Adjusting Work Speed	Page 5-24
Adjusting The Neutral Position of The Piston Pump	Page 5-24
Change of Coolant	Page 5-25
Change of Hydraulic Oil	Page 5-26
Change of Hydraulic Oil Filter	Page 5-27
Change of Air Cleaner	Page 5-28
Change of Engine Oil	Page 5-28
Replacement of Engine Oil Filter	Page 5-29
Replacement of Fuel Filter Element	Page 5-29
Grease Change of Transmission	Page 5-30
Change of Fuse	Page 5-31
Check The Operation Status of The Relay	Page 5-32
Removal of Mower Unit	Page 5-33

Maintenance

Maintenance Precautions

⚠ Caution

First, learn well the maintenance operations you plan to perform.

Important

Use tools appropriate for each maintenance operation.

Important

For the safe and best performance of your machine, use Baroness genuine parts for replacement and accessories.
Please note that our product warranty may be void if you use non-genuine parts for replacement or accessories.

Maintenance Schedule

LM315GC (Diesel Model)

Follow the maintenance schedule below.

- . . . Inspect, adjust, supply, clean
- . . . Replace (first time)
- △ . . . Replace

Maintenance Item		Before Work	After Work	Every Week	Every 8 hrs.	Every 50 hrs.	Every 100 hrs.	Every 200 hrs.	Every 400 hrs.	Every 500 hrs.	Every 800 hrs.	Every 1500 hrs.	Every 3000 hrs.	every month	every 6 months	Every year	Every 2 years	Every 4 years	When Required	Remarks	
Engine	*1	Check engine oil level	○																		
	*1	Check fuel level	○																		
	*1	Check coolant level	○																		
	*1	Open air cleaner evacuator valve to remove dust	○		○																Open valve every week or daily in dusty conditions
		Clean engine area		○																	
		Clean radiator screen		○																	
		Clean radiator core		○																	
	*1.*5	Check fuel hoses and clamp bands					○														

Maintenance

Maintenance Item		Before Work	After Work	Every Week	Every 8 hrs.	Every 50 hrs.	Every 100 hrs.	Every 200 hrs.	Every 400 hrs.	Every 500 hrs.	Every 800 hrs.	Every 1500 hrs.	Every 3000 hrs.	every month	every 6 months	Every year	Every 2 years	Every 4 years	When Required	Remarks
Engine	*1	Adjust fan belt tension				○	○													50 hours first change, every 100 hours thereafter
	*1	Clean fuel filter				○	○													50 hours first change, every 100 hours thereafter
		Check cooling fan cracks				○	○													50 hours first change, every 100 hours thereafter
	*1	Change engine oil				●	△													50 hours first change, every 100 hours thereafter
	*1	Replace oil filter cartridge				●	△													50 hours first change, every 200 hours thereafter
	*1.*5	Clean air cleaner element (Replace the element after 6-time cleaning)					○									△				Replace every 6 cleanings or every year whichever comes earlier Air cleaner should be cleaned more often in dusty conditions than in normal conditions
	*5	Check intake air line (air cleaner hose)						○												
	*1	Check radiator hoses and clamp bands						○							○					Check every 200 hours or 6 months whichever comes earlier
	*1.*5	Replace fuel filter element							△											
		Clean radiator interior															○			
	*1	Replace fan belt								△										

Maintenance

Maintenance Item		Before Work	After Work	Every Week	Every 8 hrs.	Every 50 hrs.	Every 100 hrs.	Every 200 hrs.	Every 400 hrs.	Every 500 hrs.	Every 800 hrs.	Every 1500 hrs.	Every 3000 hrs.	every month	every 6 months	Every year	Every 2 years	Every 4 years	When Required	Remarks
Engine	*4	Check valve clearance									○									
	*4.*5	Check injection nozzle										○								
	*4.*5	Check injection pump											○							
	*1	Change radiator coolant (L.L.C.)																△		
	*1	Replace radiator hoses and clamp bands																△		
	*1.*4.*5	Replace fuel hoses and clamps																△		
	*5	Replace intake air line (air cleaner hose)																△		
Main vehicle		Check hydraulic oil level	○																	
		Check hydraulic hoses condition (Moving part)	○																	
		Check tire pressures and condition	○																	
		Check V belt	○																	
		Check traveling pedal motion	○																	
		Check brake function	○																	
		Check brake wire	○																	
		Check oil or water leaks	○																	
		Check damaged parts	○																	
		Check tightening bolts and nuts	○																	
		Check light illumination	○																	
		Check meters and lamps	○																	By starting the engine
		Check interlock system safety function	○																	By starting the engine

Maintenance

Maintenance Item		Before Work	After Work	Every Week	Every 8 hrs.	Every 50 hrs.	Every 100 hrs.	Every 200 hrs.	Every 400 hrs.	Every 500 hrs.	Every 800 hrs.	Every 1500 hrs.	Every 3000 hrs.	every month	every 6 months	Every year	Every 2 years	Every 4 years	When Required	Remarks	
Main vehicle		Check steering wheel motion (Lock to lock)	○																	By starting the engine	
		Clean machine exterior		○																	
		Check electrical wiring condition (Damage, defacement and joint looseness)					○	○													50 hours first check, every 100 hours thereafter
		Check looseness of wheel mounting bolt					○	○													50 hours first check, every 100 hours thereafter
		Grease and Lubricate all moving parts					○														
	*3	Grease and Lubricate flexible wires	○		○	○															Maintenance schedules differ according to greasing points
		Replace hydraulic oil						●		△											100 hours first change, every 500 hours thereafter
		Replace hydraulic oil filter						●		△											100 hours first change, every 500 hours thereafter
	*2	Check exterior of battery						○							○						Check every 100 hours or every month whichever comes earlier
	*2	Clean exterior of battery						○							○						Check every 100 hours or every month whichever comes earlier
*2	Check mounting bracket of battery						○							○						Check every 100 hours or every month	

Maintenance

Maintenance Item		Before Work	After Work	Every Week	Every 8 hrs.	Every 50 hrs.	Every 100 hrs.	Every 200 hrs.	Every 400 hrs.	Every 500 hrs.	Every 800 hrs.	Every 1500 hrs.	Every 3000 hrs.	every month	every 6 months	Every year	Every 2 years	Every 4 years	When Required	Remarks	
Main vehicle	*2	Check mounting bracket of battery					○							○						whichever comes earlier	
	*2	Check looseness and corrosion of battery terminals					○							○						Check every 100 hours or every month whichever comes earlier	
	*2	Check battery fluid level					○							○						Check every 100 hours or every month whichever comes earlier	
		Check hydraulic hoses condition (Fixed part)							○								○			Check every 200 hours or every year whichever comes earlier	
	*3	Adjust air gap of EM clutch															○			Air gap 0.2-0.4mm (0.008-0.016in)	
		Check aligning shafts of engine and pump																○		Visual check	
		Replace hydraulic hoses (Moving part)																△			
		Replace hydraulic hoses (Fixed part)																	△		
		Adjust brakes																		○	
		Replace brake shoe																		△	
		Replace brake cables																		△	
	*2	Replace battery																		△	
Mower unit		Check blade condition (Reel cutter and Bedknife)	○																		
		Check cover condition	○																		
		Check roller condition	○																		

Maintenance

Maintenance Item		Before Work	After Work	Every Week	Every 8 hrs.	Every 50 hrs.	Every 100 hrs.	Every 200 hrs.	Every 400 hrs.	Every 500 hrs.	Every 800 hrs.	Every 1500 hrs.	Every 3000 hrs.	every month	every 6 months	Every year	Every 2 years	Every 4 years	When Required	Remarks	
Mower unit	Check groomer condition	<input type="radio"/>																			
	Engage blades	<input type="radio"/>																			
	Check mowing height	<input type="radio"/>																			
	Adjust groomer	<input type="radio"/>																			
	Check damaged parts	<input type="radio"/>																			
	Check tightening bolts and nuts	<input type="radio"/>																			
	Clean Cutting section		<input type="radio"/>																		
	Grease				<input type="radio"/>	<input type="radio"/>															Maintenance schedules differ according to greasing points
	Replace bearings inside gearcase																<input type="checkbox"/>				
	Replace front and rear rollers bearings																<input type="checkbox"/>				
	Replace oil seals inside gearcase																<input type="checkbox"/>				
	Replace front and rear rollers oil seals																<input type="checkbox"/>				
	Replace grease inside gearcase																<input type="checkbox"/>				
	*3 Grease reel cutter shaft bearing																<input type="checkbox"/>				
	Replace CR brush bearing																<input type="checkbox"/>				
Clean and Grease Bedknife Eccentric Bushes																			<input type="radio"/>		
Adjust cutter adjustment spring																			<input type="radio"/>		

Maintenance

Maintenance

Maintenance Item		Before Work	After Work	Every Week	Every 8 hrs.	Every 50 hrs.	Every 100 hrs.	Every 200 hrs.	Every 400 hrs.	Every 500 hrs.	Every 800 hrs.	Every 1500 hrs.	Every 3000 hrs.	every month	every 6 months	Every year	Every 2 years	Every 4 years	When Required	Remarks		
Mower unit	Adjust belt tension of CR brush																			<input type="radio"/>		
	Backlap blades																				<input type="radio"/>	
	Regrind blades (Reel cutter)																				<input type="radio"/>	Grind/Replace blades as and when required

- *1: Refer to the Engine's Owner's Manual.
- *2: Refer to the Battery's Owner's Manual.
- *3: Failed maintenance may largely cause damage to the flexible wires.
- *4: Consult your local Baroness Dealer or local KUBOTA Dealer for this service.
- The items above (*5 marked) are registered as emission related critical parts by KUBOTA in the U.S. EPA nonroad emission regulation.
As the engine owner, you are responsible for the performance of the required maintenance on the engine according to the above instruction.
Please see the Engine's Warranty Statement in detail.
- The values for consumables are not guaranteed.
- Replace the steering cylinder hoses every 2 years.

Adjusted Value

Cutter adjustment spring	26.0 mm (1.024 in)	Total length of spring
Fan belt	7.0 - 9.0 mm (0.276 - 0.354 in)	Belt slack
Reel Cutter Drive Belt	13±2 mm (0.51±0.08 in)	Under load of 55.0 N (5.5 kgf)
Transmission input belt	50.0 mm (1.969 in)	Total length of spring

Jacking Up The Machine

About Jacking Up The Machine

Warning

When replacing a tire or beginning any other maintenance or repairs, be sure to chock the wheels to prevent the machine from moving. Before jacking up the machine, park it on a hard, flat surface such as a concrete floor and remove any obstacles that could prevent you from performing the work safely.

When necessary, use an appropriate chain block, hoist, or jack.

Support the machine securely with jack stands or appropriate blocks.

Failure to do so may cause the machine to move or fall, resulting in injury or death.

Use the jack-up points identified in this manual when jacking up the machine.

Only place a jack under the jack-up points specified.

Placing a jack at any other point could result in damage to the frame or other parts.

Jack-Up Points

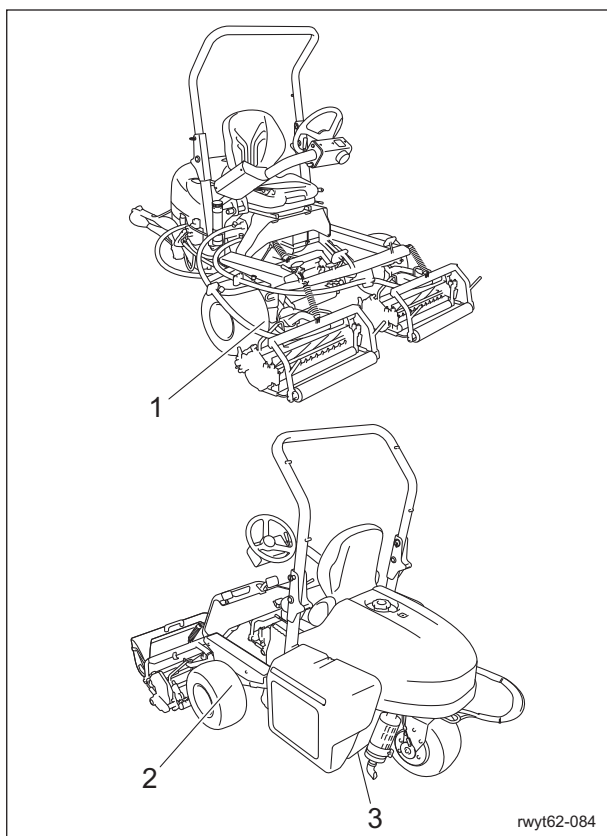

Jack-Up Points_001

1	Front right frame
2	Front left frame
3	Engine mount frame

1. Front right frame

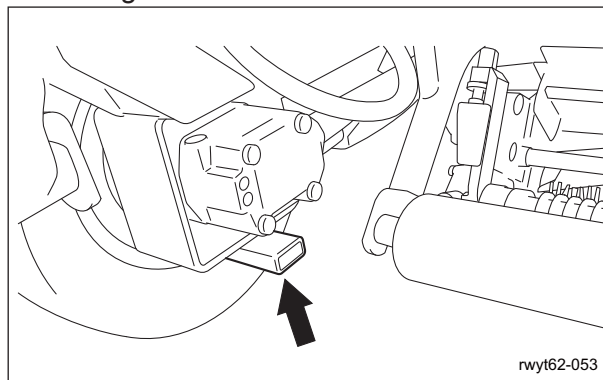

Jack-Up Points_002

2. Front left frame

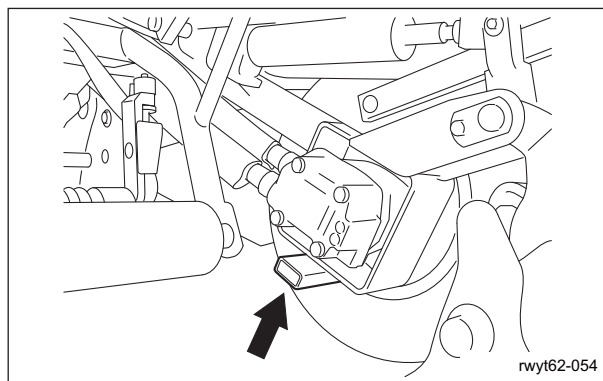

Jack-Up Points_003

3. Engine mount frame

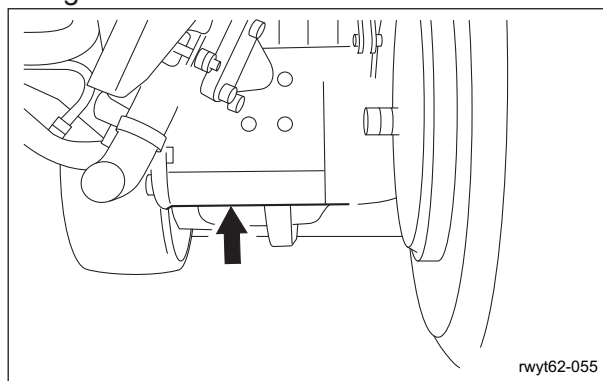

Jack-Up Points_004

Maintenance

Greasing

About Greasing

Since there may be adhesion or damage due to lack of grease on moving parts, they must be greased.

Add urea-based No. 2 grease in accordance with the Maintenance Schedule.

Other locations where the specified grease or lubricant is used are indicated in "Greasing Points".

Add grease using the specified grease or lubricant.

Greasing Points

Grease nipples are installed in the following locations.

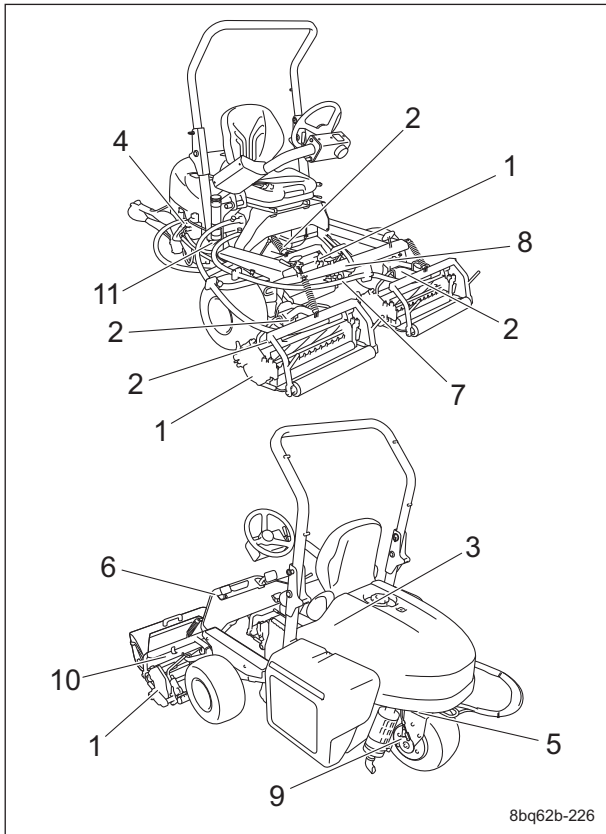

Greasing Points_001

	Location	No. of greasing points	Greasing schedule		
			A	B	C
1	Mower unit	36	A	B	
2	Mower arm fulcrum	6		B	
3	Belt tension lever	1		B	
4	Neutral position area	1		B	
5	Rear wheel pivot	1		B	
6	Mower pedal shaft fulcrum	1		B	
7	Flexible wire bracket	1		B	
8	Traveling pedal shaft fulcrum	1		B	
9	Rear wheel brake lever shaft	1		B	
10	Flexible wire edge	3		B	
11	Flexible wire	6	A		C

Add grease to A every 8 hours, to B every 50 hours and to C before work.

1. Mower unit

Each mower unit has 12 points.

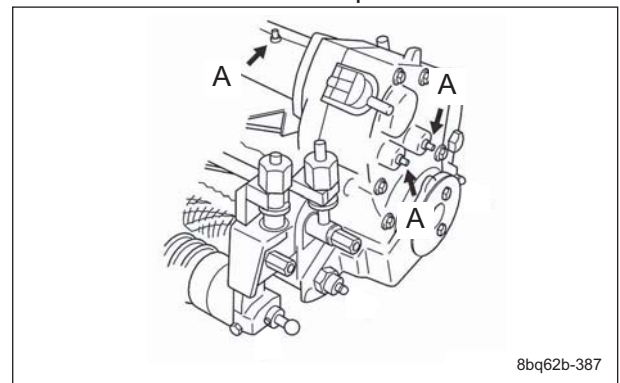

8bq62b-387

Greasing Points_002

Front roller

Note:

Depending on the specifications, this function may not be available.

Split roller has no greasing point.

Left side

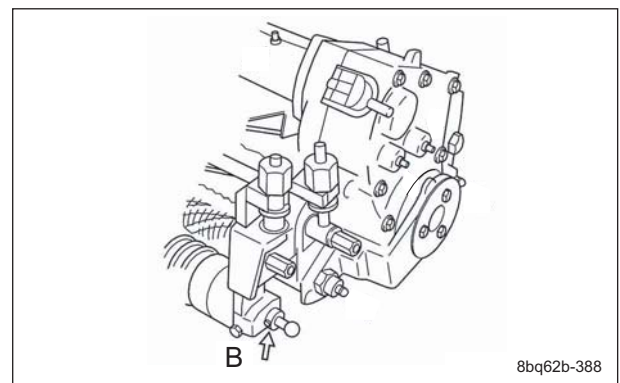

8bq62b-388

Greasing Points_003

Right side

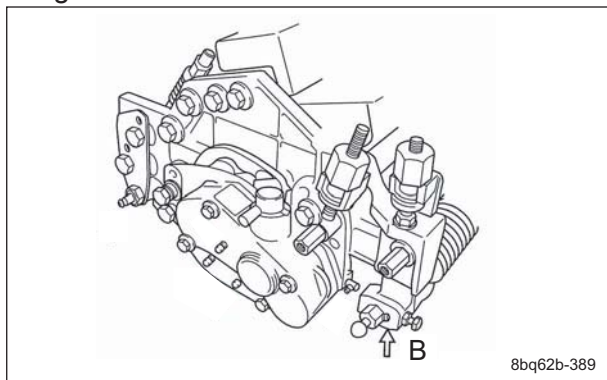

Greasing Points_004

Rear roller

Note:

Depending on the specifications, this function may not be available.

Left side

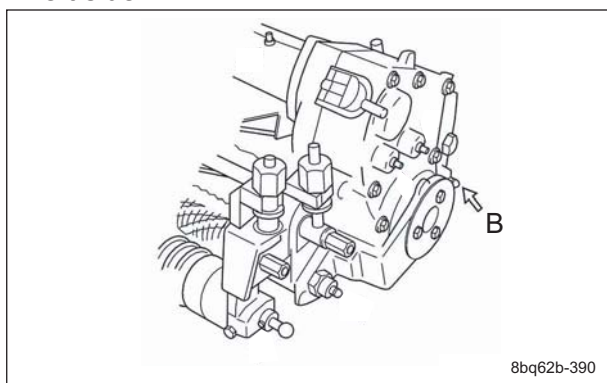

Greasing Points_005

Right side

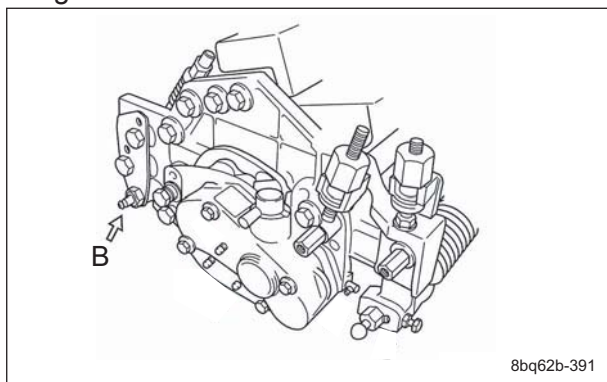

Greasing Points_006

Groomer

Note:

Depending on the specifications, this function may not be available.

Left side

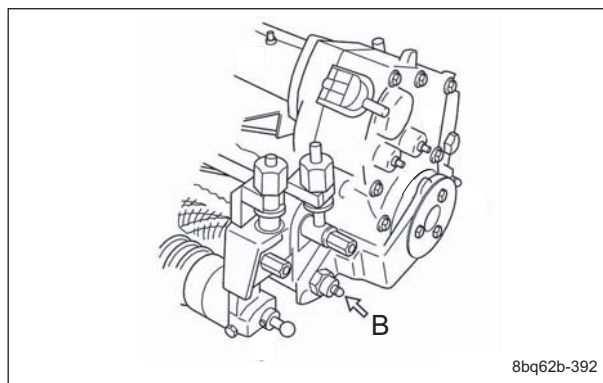

Greasing Points_007

Right side

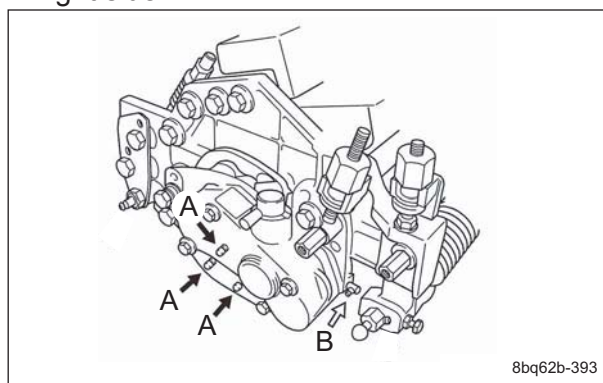

Greasing Points_008

Maintenance

2. Mower arm fulcrum

Important

Without greasing the mower arm fulcrum, the worn shaft can cause backlash in the lift arm and mower arm. The backlash may influence up-down range of the mower unit and cutting finish.

[1] Front mower unit

There are two greasing points on each mower unit.

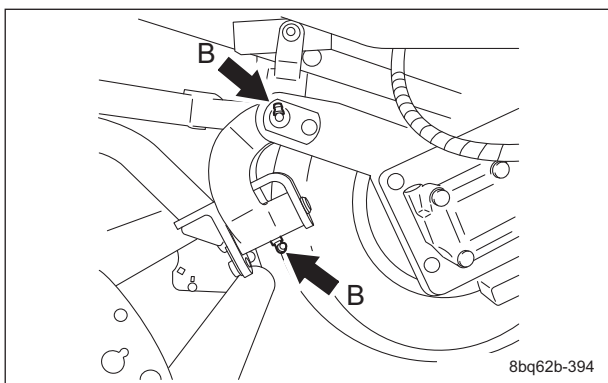

Greasing Points_009

[2] Rear mower unit

There are two locations.

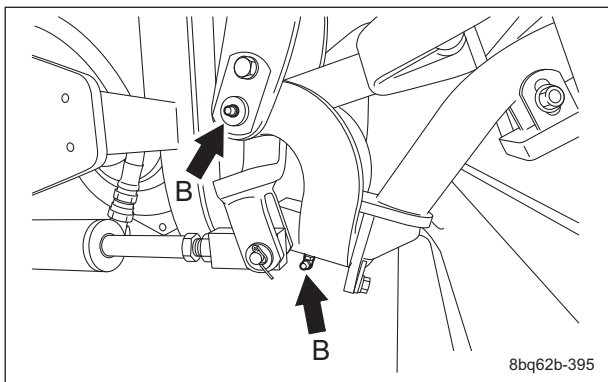

Greasing Points_010

3. Belt tension lever

Important

Without greasing the tension lever, it can adhere.

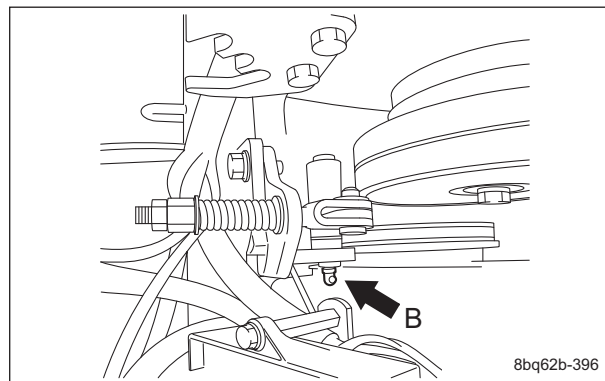

Greasing Points_011

4. Neutral position area

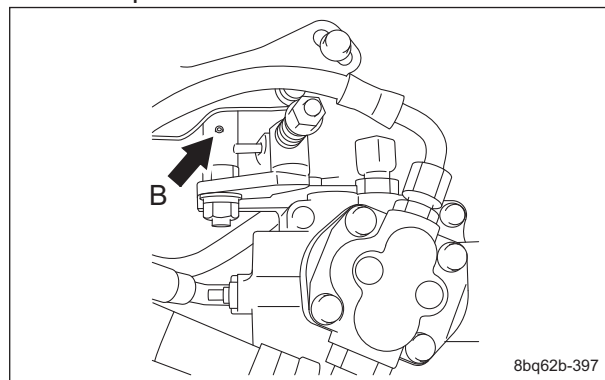

Greasing Points_012

5. Rear wheel pivot

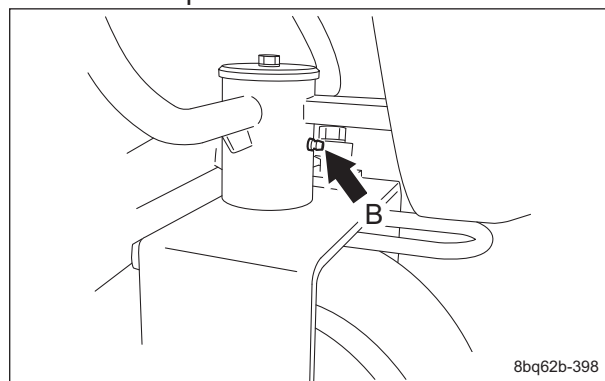

Greasing Points_013

6. Mower pedal shaft fulcrum

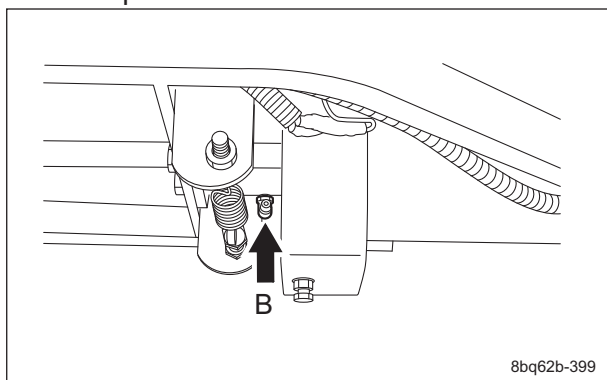

Greasing Points_014

7. Flexible wire bracket

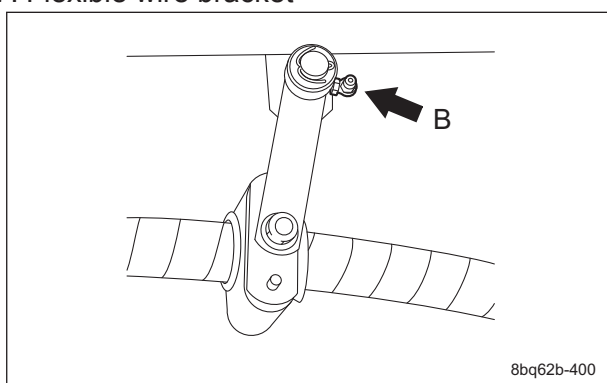

Greasing Points_015

8. Traveling pedal shaft fulcrum

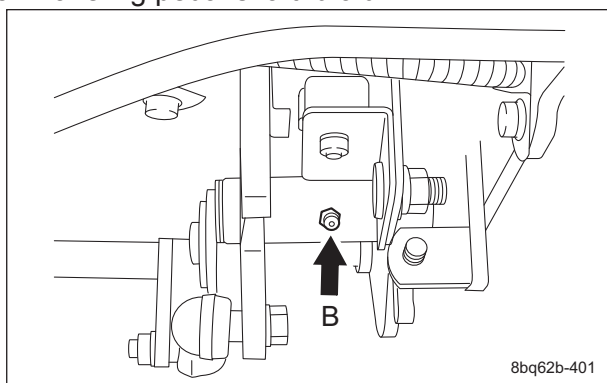

Greasing Points_016

9. Rear wheel brake lever shaft

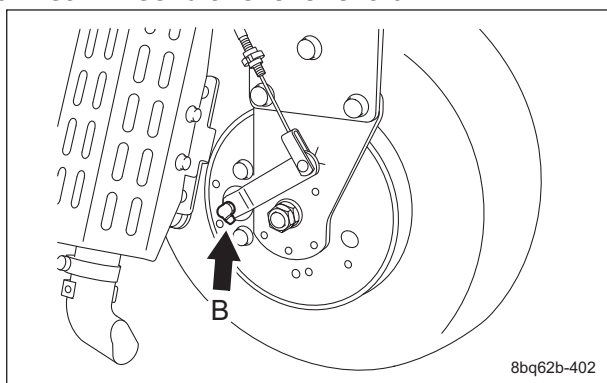

Greasing Points_017

10. Flexible wire edge

There is one greasing point on each flexible wire.

Grease by one stroke (1.0mL) every 50 hours.

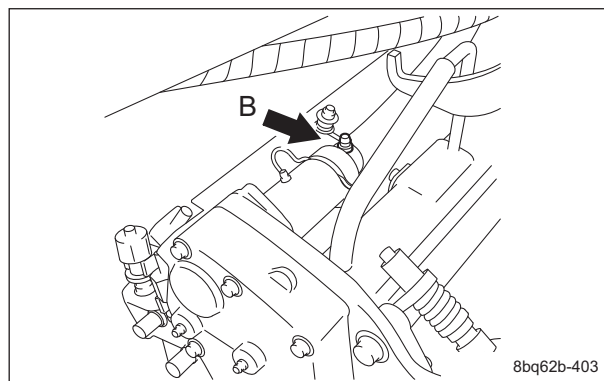

Greasing Points_018

Important

Lack of grease in the flexible wire may cause damage to it.

Grease according to the maintenance schedule.

The inner cable is a strand wire. Lack of grease in the strand wire may cause friction inside it resulting in damage due to abnormal heat generation.

11. Flexible wire

Use Moly speed grease No.2.

Note:

A Bentone grease formulated with molybdenum disulfide that has excellent wear resistance and anti-seizure properties. Little dripping at high temperature.

Main vehicle side

Screw in the grease cup by one turn for greasing before work.

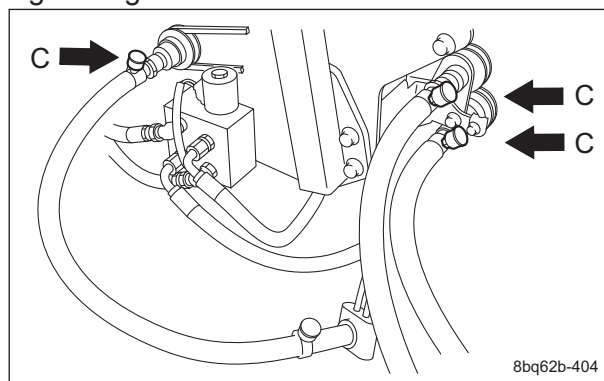

Greasing Points_019

Maintenance

Central part
Screw in the grease cup by one turn for greasing every 8 hours.

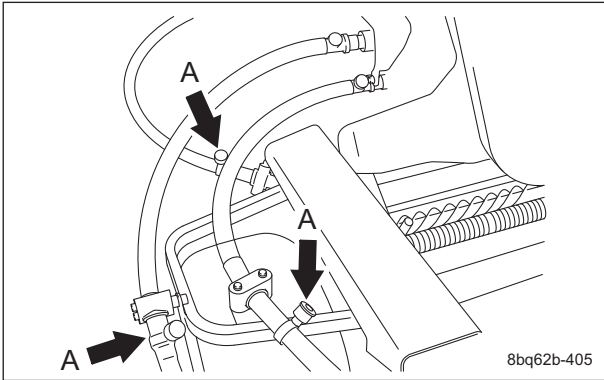

Greasing Points_020

Note:

Follow the steps below for greasing if the grease cup of the flexible wire has been screwed in fully.

- [1] Remove the grease cup.
- [2] Add grease fully to the grease cup without aeration.
- [3] Screw in the grease cup by two turns for installation.

Lubrication

About Lubrication

It is necessary to lubricate moving parts so that they will not become stuck or damaged. The locations where lubricant is used are indicated in "Lubricating Points". Apply the lubricant.

Lubricating Points

Apply lubricant at the following locations every 50 hours of operation.

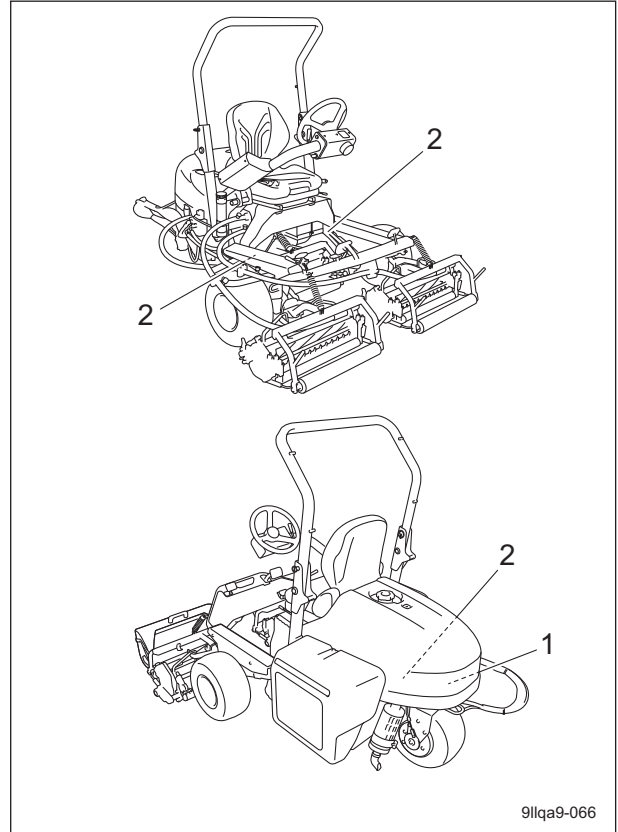

Lubricating Points_001

	Location	No. of lubricating points
1	Steering cylinder spherical bearing	1
2	Mower up/down cylinder spherical bearing	3

- 1. Steering cylinder spherical bearing
There is one point.

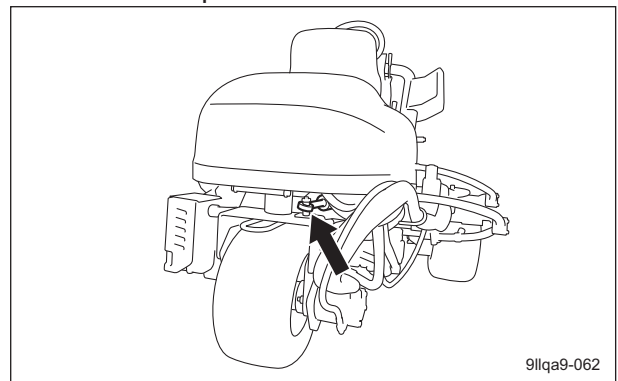

Lubricating Points_002

2. Mower up/down cylinder spherical bearing
There is one point each on the mower up/
down cylinders.

Rear mower unit

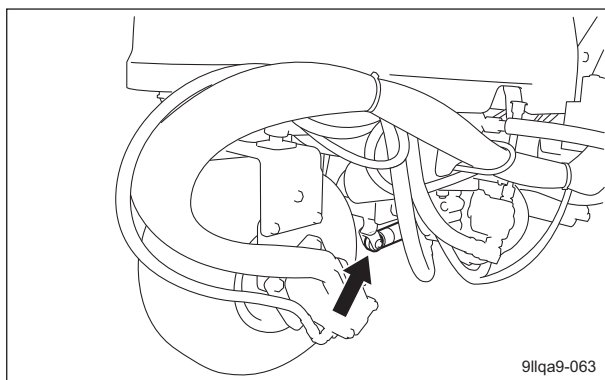

Lubricating Points_003

Left mower unit

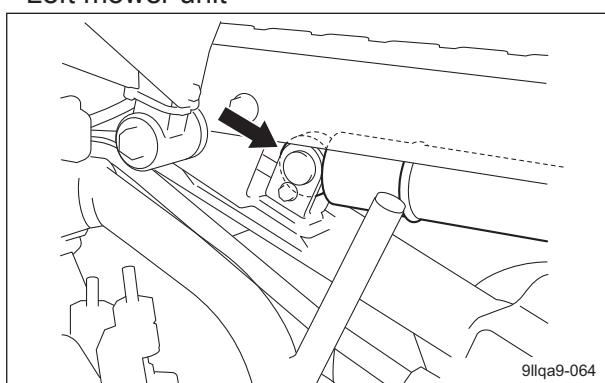

Lubricating Points_004

Right mower unit

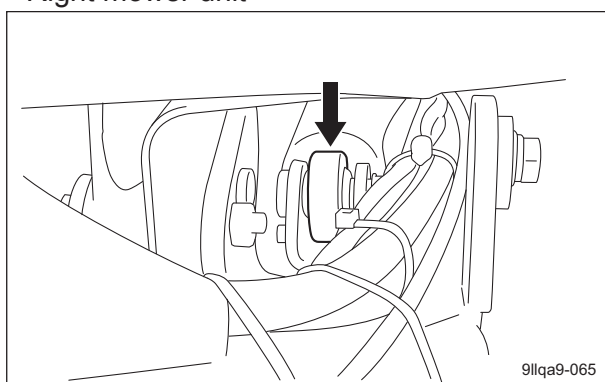

Lubricating Points_005

Maintenance Work

Back Lapping

Back lapping is work similar to sharpening a cooking knife. If the edges of the reel cutter (cutting cylinder) and the bed knife (bottom blade) become blunt and make cutting difficult, both the reel cutter (cutting cylinder) and the bed knife (bottom blade) should be simultaneously sharpened by reversing the reel cutter (cutting cylinder) with an abrasive paste applied.

However, back lapping is a temporary measure and would not restore the sharpness completely.

If the edges of the reel cutter (cutting cylinder) and the bed knife (bottom blade) become blunt and make cutting difficult, follow the steps below to perform back lapping.

⚠ Warning

During back lapping, the reel cutter (cutting cylinder) rotates. Keep hands and feet away from moving parts.

⚠ Caution

Be careful not to inhale exhaust gas during back lapping.

⚠ Caution

Do not perform back lapping with any other persons.

⚠ Caution

Be sure to stop the engine before and during shifting the transmission selector. Otherwise, your hands may get caught in the belt.

1. Have the following items ready: Strips of newspaper, Abrasive [Back lapping powder mixed with oil; or gel compound (Baroness genuine abrasive)], Brush.

Maintenance

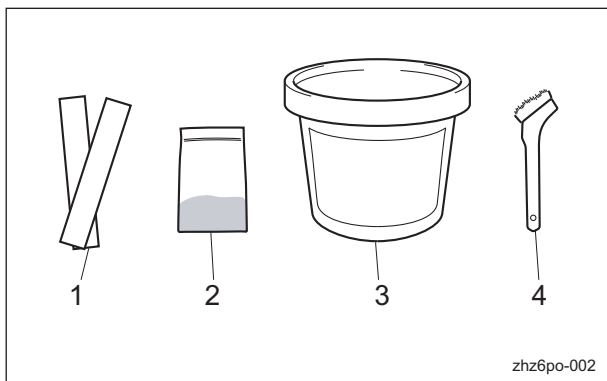

Back Lapping_001

1	Newspaper
2	Back lapping powder
3	Gel compound
4	Brush

Note:

The mixing ratio for the abrasive, in volume, is one part back lapping powder (#200 - #400) to three or four parts oil.

Caution

When handling the reel cutter (cutting cylinder) or bed knife (bottom blade), wear gloves to protect your hands. Pay attention not to let the reel cutter (cutting cylinder) catch your gloves. Otherwise, you may injure your hand or fingers.

Important

Check the sharpness of the blade by checking the blade engagement after cutting grass.

2. Stop the engine.
3. Set the reel reverse lever for the mower units to the "Neutral" position.
4. Insert one or two strips of newspaper into the space between the reel cutter (cutting cylinder) and the bed knife (bottom blade) at an angle of 90 degrees. Then, rotate the reel cutter (cutting cylinder) counter-clockwise (when you face the mower unit from the left) to check the sharpness of the blades.
5. Check the sharpness of the entire range (three or four points) of the reel cutter (cutting cylinder).
6. Using a piece of chalk, mark locations on the blade that are sharp.
7. Set the reel reverse lever for the mower units to be back lapped to the "Reverse" position. Shift the lever(s) to the "Neutral" position for the mower unit(s) for which you will not perform back lapping.
8. Set the transmission selector lever to the "Back lapping" position.
9. Take the operator's seat, apply the parking brake and then start the engine.
10. Lower all the mower units to the ground.
11. Reduce the engine rotation speed.
12. Set the reel rotation switch to the "Rotation" position to reverse the reel cutter (cutting cylinder).
13. Apply the abrasive evenly with the brush on the top side of reel cutter (cutting cylinder) where the newspaper was cut well or of chalk-marked locations. (Never apply to blunt areas.)
14. Let the reel rotate for a while and, when contact noise is no longer heard, return the reel rotation switch to the "Stop" position to stop the reel cutter (cutting cylinder).
15. Raise all the mower units.
16. Stop the engine.
17. Wash off or wipe off with a cloth, etc., the abrasive from the reel cutter (cutting cylinder), and then check it for sharpness.
18. Repeat steps 3 to 17 until the entire range (three or four points) of the reel cutter (cutting cylinder) will be uniformly sharpened.
19. Lower all the mower units to the ground.
20. Finally, apply abrasive to the entire blade width of the reel cutter (cutting cylinder) and perform final back lapping.
21. Return the reel rotation switch to the "Stop" position to stop the rotation of the reel cutter (cutting cylinder), stop the engine, and then wash off the abrasive using a washer etc.
22. Set the transmission selector lever to the desired position.
23. Set the reel reverse lever to the "Neutral" position.
24. While checking the blade for sharpness, adjust blade engagement.

Adjusting CAM

When the gap at the left frame side between the reel cutter (cutting cylinder) and the bed knife (bottom blade) appears.

1. Loosen the locknut and turn the left cam bush clockwise for the gap size.
When you raise the bed knife (bottom blade) for 0.1mm (0.039 inch), turn the left cam bush clockwise for 30 degrees.

2. Once the adjustment completed, tighten the locknut securely.

When the gap at the right frame side between the reel cutter (cutting cylinder) and the bed knife (bottom blade) appears.

1. Loosen the locknut and turn the right cam bush anticlockwise for the gap size.
2. Once the adjustment completed, tighten the locknut securely.

Note:

The figure below shows the situation when you see from the left frame.

The right frame is mirror reversed.

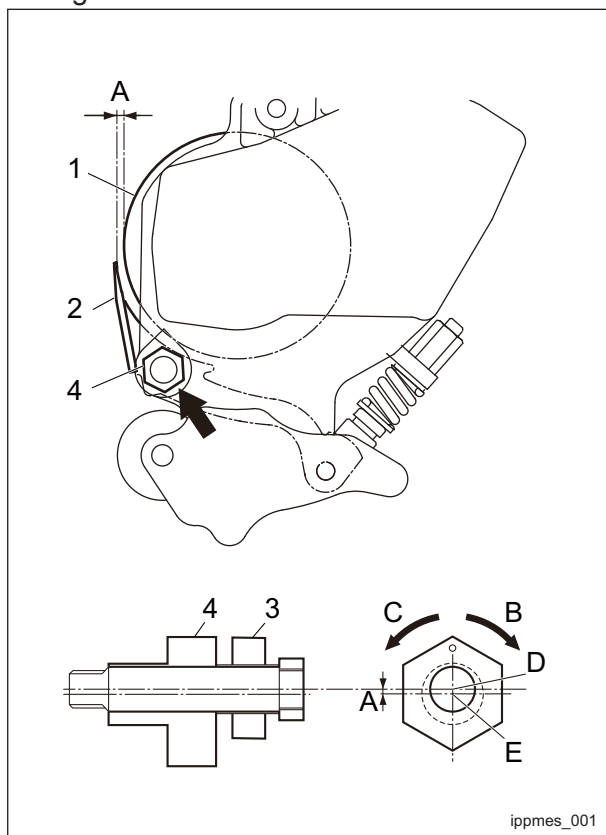

Adjusting CAM_001

1	Reel cutter (Cutting cylinder)
2	Bed knife (Bottom blade)
3	Lock nut
4	Cam bush
A	Max 0.3 mm (0.012 inch)
B	Bed knife (bottom blade) moving up
C	Bed knife (bottom blade) moving down
D	Center of cutter pin
E	Center of cam bush

Sharpening of Reel Cutter (Cutting Cylinder)

The sharpening of the reel cutter (cutting cylinder) consists in maintaining its roundness and creating a relief (second edge face). This work should be performed if the sharpness cannot be restored, even after back lapping, or if the relief (second edge face) has worn away.

Sharpen the reel cutter (cutting cylinder) when the sharpness cannot be restored, even after back lapping, or when the relief (second edge face) has worn away, there is full contact or back lapping takes too much time.

In addition, if the reel cutter (cutting cylinder) becomes worn and its shape conical, perform cylindrical grinding to return it to a cylindrical shape.

For sharpening the reel cutter (cutting cylinder), contact your dealer or Baroness unless you have a grinding machine.

⚠ Caution

Both the reel cutter (cutting cylinder) and the bed knife (bottom blade) are edged tools. Handle them carefully, since they could cut your hands and feet.

⚠ Caution

Wear gloves when touching edged tools to avoid cutting your hands.

The criteria for sharpening the reel cutter (cutting cylinder) are described below. However, these criteria are only references and do not guarantee performance of a reel cutter (cutting cylinder).

Maintenance

1. If the outer diameter of the reel cutter (cutting cylinder) after sharpening is more than the usage limit, the reel cutter (cutting cylinder) can be sharpened.

New		Usage limit	
Dimension A (Outer diameter of reel cutter (cutting cylinder))	Dimension B (Distance from blade edge to outer edge of reel cutter (cutting cylinder) shaft)	Dimension A (Outer diameter of reel cutter (cutting cylinder))	Dimension B (Distance from blade edge to outer edge of reel cutter (cutting cylinder) shaft)
128 mm (5.04 in)	51.3 mm (2.02 in)	118 mm (4.65 in)	46.3 mm (1.82 in)

Note:

The outer diameter of the reel cutter (cutting cylinder) shaft is 25.4 mm (1.00 in).

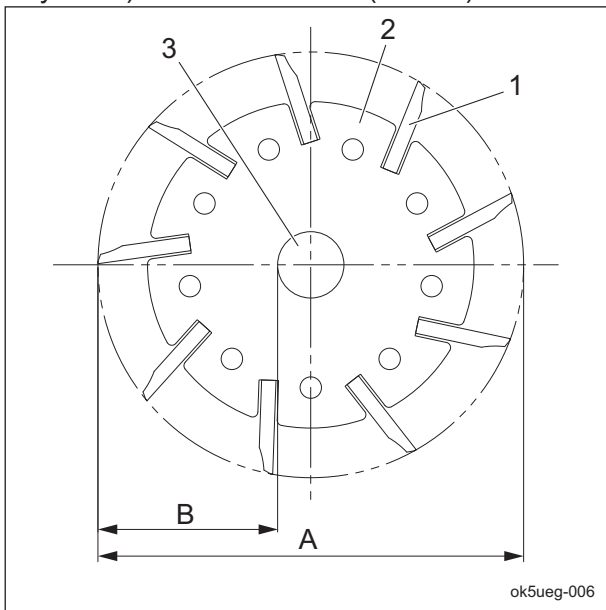

Sharpening of Reel Cutter (Cutting Cylinder)_001

1	Reel cutter (cutting cylinder) blade
2	Reel cutter (cutting cylinder) disc
3	Reel cutter (cutting cylinder) shaft
A	Outer diameter of reel cutter (cutting cylinder)
B	Distance from blade edge to outer edge of reel cutter (cutting cylinder) shaft

2. Sharpening is necessary when the reel cutter (cutting cylinder) reaches a condition described below.

[1] When the sharpening width (length of contacting surface of bed knife (bottom blade)) for the outer diameter of the reel cutter (cutting cylinder) is greater than the usage limit.

Outer diameter of reel cutter (cutting cylinder) (new part)	Usage limit of sharpening width for outer diameter of reel cutter (cutting cylinder)
128 mm (5.04 in)	2.5 mm (0.10 in) (factory-recommended)

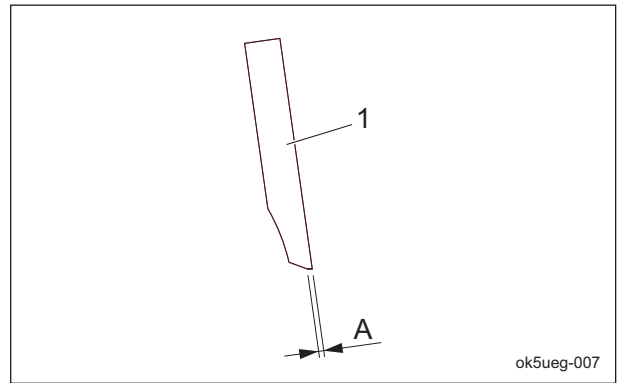

Sharpening of Reel Cutter (Cutting Cylinder)_002

1	Reel cutter (cutting cylinder) blade
A	Sharpening width for outer diameter of reel cutter (cutting cylinder)

[2] When the edges become blunt or the blade edge cannot be formed with back lapping

[3] When the reel cutter (cutting cylinder) becomes worn and its shape conical, or when blade engagement adjustment cannot be performed

Replacement of Reel Cutter (Cutting Cylinder)

⚠ Caution

Both the reel cutter (cutting cylinder) and the bed knife (bottom blade) are edged tools. Handle them carefully, since they could cut your hands and feet.

⚠ Caution

Wear gloves when touching edged tools to avoid cutting your hands.

The criteria for replacing the reel cutter (cutting cylinder) are described below.

However, these criteria are only a reference and do not guarantee performance like that of a new reel cutter (cutting cylinder).

1. When the outer diameter of the reel cutter (cutting cylinder) is less than the usage limit

New		Usage limit	
Dimension A (Outer diameter of reel cutter (cutting cylinder))	Dimension B (Distance from blade edge to outer edge of reel cutter (cutting cylinder) shaft)	Dimension A (Outer diameter of reel cutter (cutting cylinder))	Dimension B (Distance from blade edge to outer edge of reel cutter (cutting cylinder) shaft)
128 mm (5.04 in)	51.3 mm (2.02 in)	118 mm (4.65 in)	46.3 mm (1.82 in)

Note:

The outer diameter of the reel cutter (cutting cylinder) shaft is 25.4 mm (1.00 in).

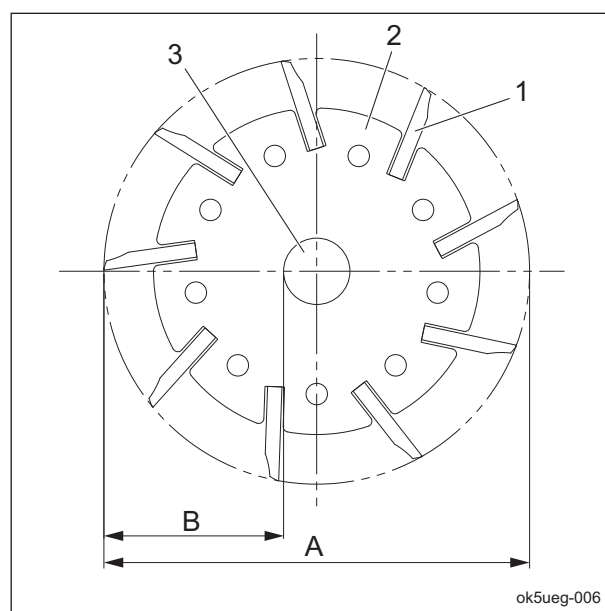

Replacement of Reel Cutter (Cutting Cylinder)_001

1	Reel cutter (cutting cylinder) blade
2	Reel cutter (cutting cylinder) disc
3	Reel cutter (cutting cylinder) shaft
A	Outer diameter of reel cutter (cutting cylinder)
B	Distance from blade edge to outer edge of reel cutter (cutting cylinder) shaft

Attaching Reel Cutter (Cutting Cylinder)

⚠ Caution

Both the reel cutter (cutting cylinder) and the bed knife (bottom blade) are edged tools. Handle them carefully, since they could cut your hands and feet.

Follow the instruction below to replace the reel cutter bearing (right/left) and seal. Use 30204JRP6 as bearing.

1. Fill up the bearings and seal with grease (Excelite EP No.2).
2. Attach the reel cutter (cutting cylinder) to the frame like the figure below.
3. Tighten the inner nut and check the bearing for backlash.
4. Loosen the inner nut at the level that the reel cutter (cutting cylinder) can be rotated lightly by your hand and you don't feel the backlash.

Tightening torque: 7 N-m (71.4 kgf-cm / 61.96 lb-in)

Maintenance

5. Tighten the outer locknut.

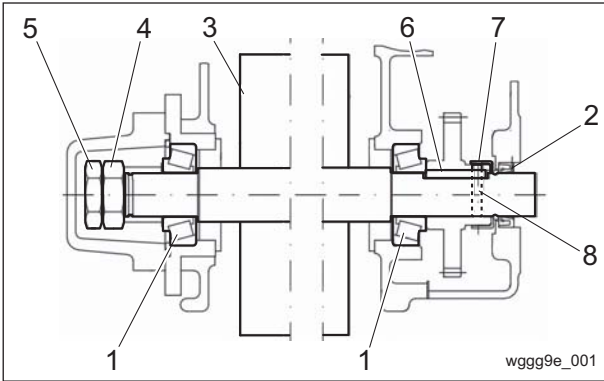

Attaching Reel Cutter (Cutting Cylinder)_001

1	Bearing
2	Seal
3	Reel cutter (Cutting cylinder)
4	Inner nut
5	Outer nut
6	Key
7	Cover
8	Pin

Standard blade

Replace the bed knife (bottom blade) before it no longer has a front face.

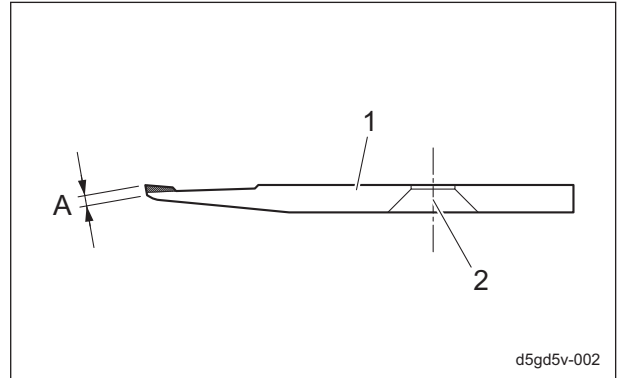

Replacement of Bed Knife (Bottom Blade)_001

1	Bed knife (bottom blade)
2	Mounting hole
A	Front face

High-speed-steel-tipped blade

Replace the bed knife (bottom blade) before it no longer has a tip.

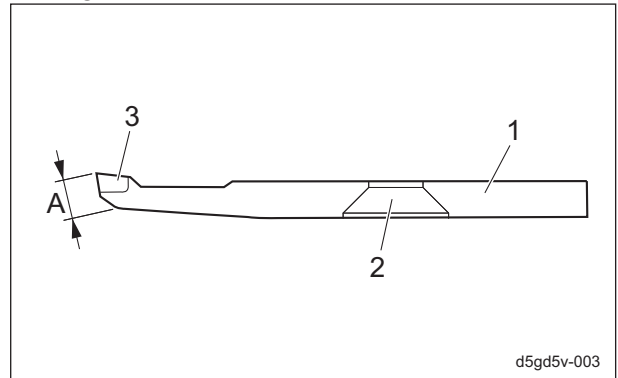

Replacement of Bed Knife (Bottom Blade)_002

1	Bed knife (bottom blade)
2	Mounting hole
3	Tip
A	Front face

Replacement of Bed Knife (Bottom Blade)

⚠ Caution

Both the reel cutter (cutting cylinder) and the bed knife (bottom blade) are edged tools. Handle them carefully, since they could cut your hands and feet.

⚠ Caution

Wear gloves when touching edged tools to avoid cutting your hands.

The criteria for replacing the bed knife (bottom blade) are described below.

1. When the reel cutter (cutting cylinder) is ground
2. When the reel cutter (cutting cylinder) is replaced
3. When the bed knife (bottom blade) is worn

Removing/Installing Tires

Front Tire

Follow the steps below to remove the front tire:

1. Loosen the bolts.

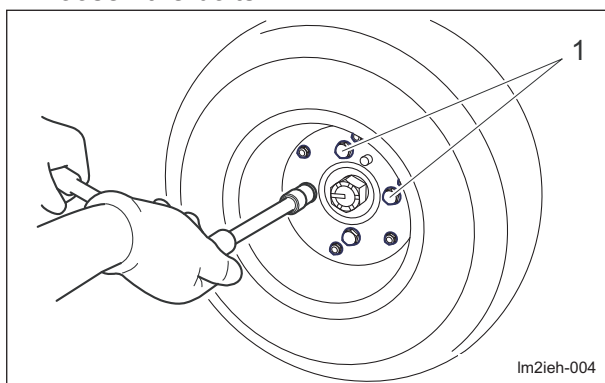

Front Tire_001

1	Heat-treated bolt
---	-------------------

2. Securely place the jack beneath the jack-up point of the front right/left frame area, and then raise it until the tire lifts off the ground. "Jack-Up Points" (Page 5-9)
3. Remove the bolts.
4. Remove the tire from the wheel mounting base.

Important

Tighten the bolts in the tightening order (crosswise).

For installing the front tires, reverse the removing procedure.

Rear Tire

Follow the steps below to remove the rear tires:

[2WD]

1. Securely place the jack beneath the jack-up points of the engine mount frame area, and then raise it until the tire lifts off the ground. "Jack-Up Points" (Page 5-9)
2. Remove the wire.
3. Remove the right/left bolts.
4. Remove the rear wheel Assy.

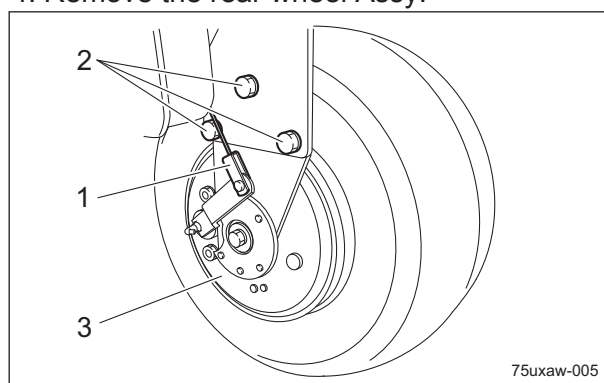

Rear Tire_001

1	Wire
2	Bolt
3	Rear wheel Assy

5. Remove the bolts.

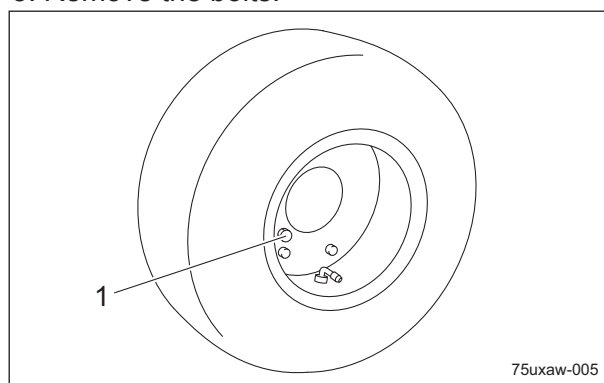

Rear Tire_002

1	Bolt
---	------

6. Remove the tire from the wheel mounting base.

Maintenance

Important

Tighten the bolts in the tightening order (crosswise).

For installing the rear tires, reverse the removing procedure.
[3WD]

1. Securely place the jack beneath the jack-up points of the engine mount frame area, and then raise it until the tire lifts off the ground. "Jack-Up Points" (Page 5-9)
2. Remove the wire.
3. Remove right/left the bolt A(s).
4. Remove the bolt B at the center.
5. Remove the brake shoe Assy.
6. Remove the brake drum.

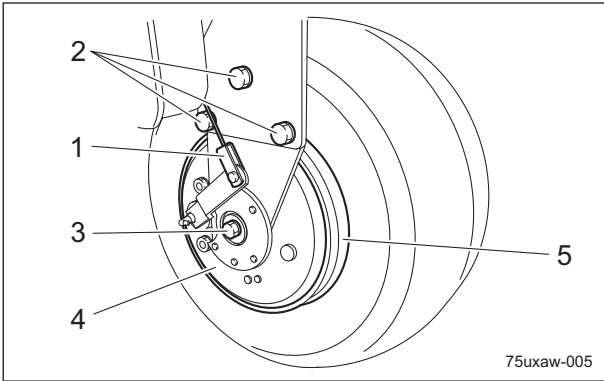

Rear Tire_003

1	Wire
2	Bolt A
3	Bolt B
4	Brake shoe Assy
5	Brake drum

7. Remove the bolts.

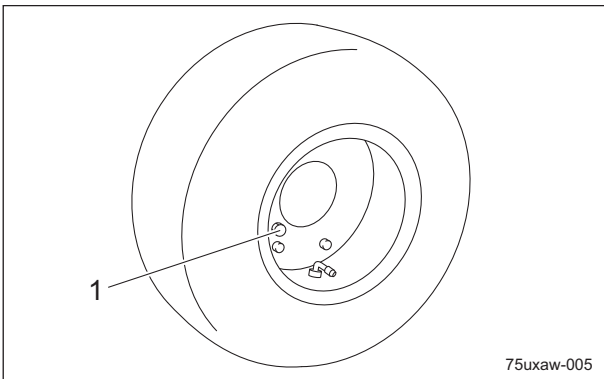

Rear Tire_004

1	Bolt
---	------

8. Remove the tire from the wheel mounting base.

Important

Tighten the bolts in the tightening order (crosswise).

For installing the rear tires, reverse the removing procedure.

Adjustment of Belt Tension

Warning

Be sure to stop the engine before adjusting the belts.

Important

Before making sure of belt tension, rotate the belt several times.

If the belt becomes slack due to frequent use, it may jump or slip. In addition, if it is overtightened, it may wear prematurely. If necessary, adjust it, and always check the belt for appropriate tension.

Fan Belt

1. Open the hood.
2. Press the middle of the belt with your finger to check the belt tension.
3. If the belt tension is inappropriate, loosen the nuts and bolts fixing the alternator, and then move the alternator to adjust the tension.

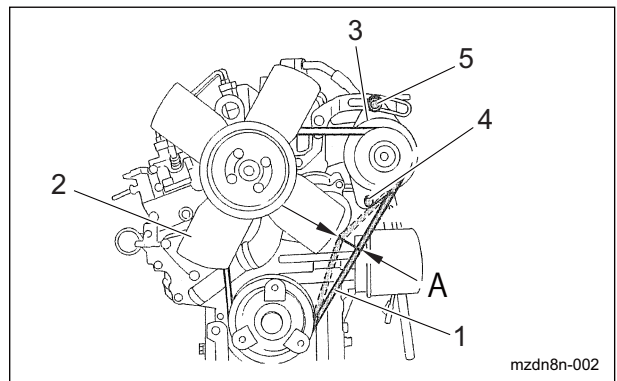

Fan Belt_001

1	Fan belt
2	Blade
3	Alternator
4	Nut
5	Bolt
A	7.0 - 9.0 mm (0.276 - 0.354 in)

Reel Cutter Drive Belt

1. Tilt the underseat cover forward and open the cover.
2. Open the hood.
3. Press the middle of the belt with your finger to check the belt tension.
4. If the belt tension is inappropriate, loosen the bolts and move the flexible wire housing (the pulley attached) with the spanner to adjust the tension.

Adjust belt tension so that the deflection may be 13 ± 2 mm (0.51 ± 0.08 in) when applying 55.0 N (5.5 kgf) load right in the middle of pulleys.

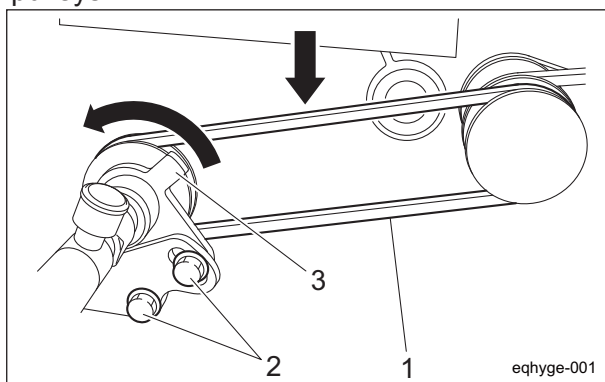

Reel Cutter Drive Belt_001

1	Reel cutter drive belt
2	Bolt
3	Flexible wire housing

Transmission Input Belt

Important

Check adhesion of the tension lever.
It may shorten the belt lifetime.

1. Tilt the underseat cover forward and open the cover.
2. Open the hood.
3. Press the middle of the belt with your finger to check the belt tension.

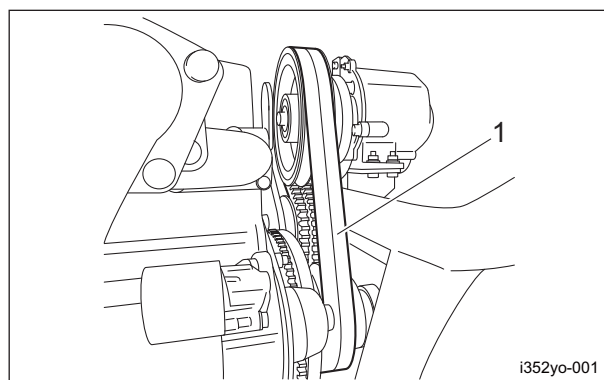

Transmission Input Belt_001

1	Engine tension belt
---	---------------------

4. Loosen the nut to adjust the length of the spring is 50.0 mm (1.969 in).

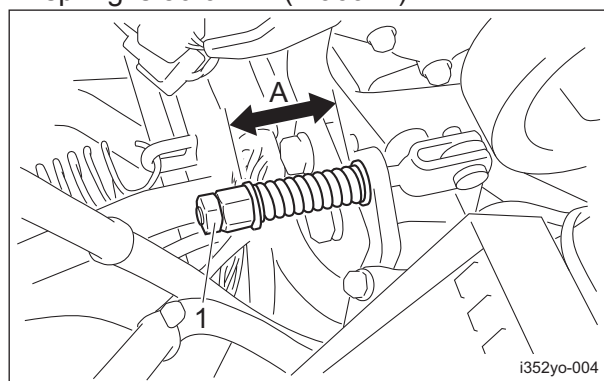

Transmission Input Belt_002

1	Nut
A	50.0 mm (1.969 in)

5. Lock it with the nut.

Maintenance

Adjustment of Parking Brake

⚠ Caution

If the brake wire is cut, the machine will be unable to stop.
If the brake wire is cracked or damaged, replace it with a new one immediately.

Important

Make sure that the brake is effective on slopes and that it is not applied any longer when you release it.
Adjust the parking brake system whenever there is any abnormality.

Adjust the parking brake by tightening the brake wire adjustment bolt.

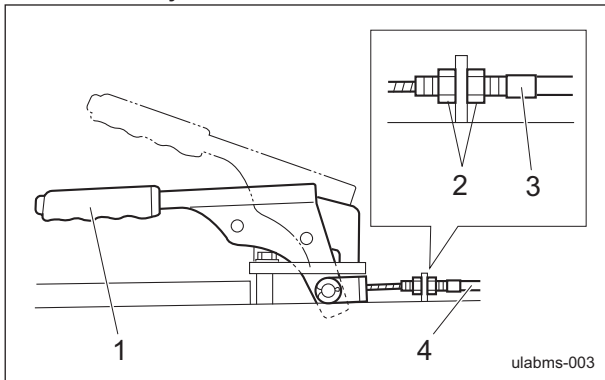

Adjustment of Parking Brake_001

1	Parking brake lever
2	Lock nut
3	Adjustment bolt
4	Brake wire

Adjusting Work Speed

1. Lower the mower units.
2. Loosen the locknut on the side of the rod head for the right cylinder to adjust the length of the bolt.
 - Length of the bolt (Longer): Slower
 - Length of the bolt (Shorter): Faster
 Once the adjustment has completed, be sure to lock with the nut.

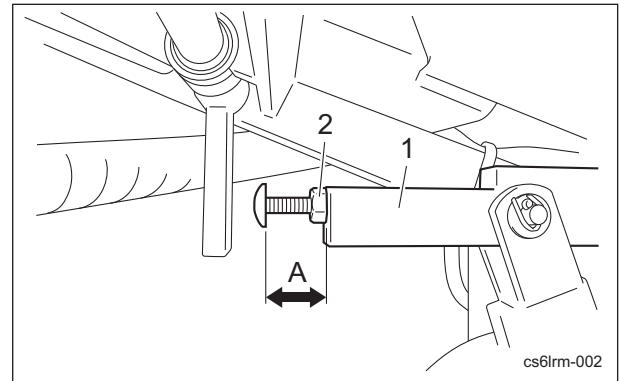

Adjusting Work Speed_001

1	Rod head
2	Lock nut
A	Length of the bolt

Adjusting The Neutral Position of The Piston Pump

⚠ Caution

Make sure not to touch rotating tires.

⚠ Caution

When adjusting the neutral position, pay close attention to abrupt start of the machine.
Place the jacks beneath the jack-up points, and then lift the machine until all the tires get off the ground.

If the machine moves forward or backward while the traveling pedals are released, they are not set to the neutral position.
Follow the steps below to make adjustments.

1. Stop the engine.
2. Place the jacks beneath the jack-up points, and then lift the machine off the ground.
"Jack-Up Points" (Page 5-9)
3. Make sure that no tires get contact with the jack stand.
4. Start the engine, and rev it up to the maximum rpm.
5. Adjust the neutral position.
 - [1] Loosen the lock nut.
 - [2] Rotate the camshaft slowly until the front wheel stops.
Find the position where the front wheel stops and lock the camshaft with the nut.

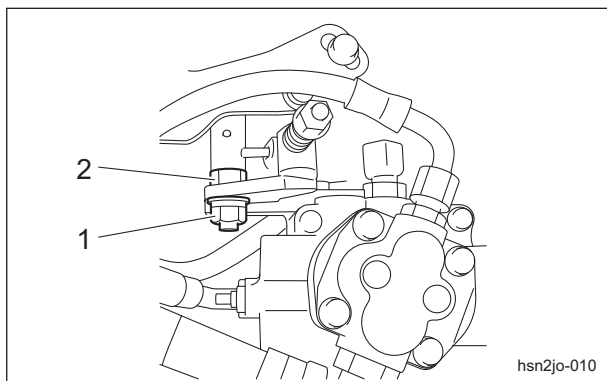

Adjusting The Neutral Position of The Piston Pump_001

1	Lock nut
2	Cam shaft

Change of Coolant

⚠ Caution

Do not touch the radiator or coolant during engine operation or immediately after the engine has been turned off. Otherwise, you may get burned due to high temperatures.

⚠ Caution

Change coolant after the engine has well cooled down.

⚠ Caution

The radiator cap is pressurized. If you remove the radiator cap while the engine is overheated, hot steam will burst out, possibly resulting in burns. Make sure that the water temperature and pressure are reduced, and then grab the cap with a thick cloth and gradually open the cap.

Important

When changing the coolant, be sure to drain it into a container and discard it in accordance with local laws and regulations.

Important

When changing the coolant, be sure to mix clean water (soft water) and antifreeze (long-life coolant), and then pour it into the radiator and reserve tank.

Important

Tightly close the radiator cap. If the cap is loose or incorrectly installed, water may leak and the engine may overheat.

When mixing antifreeze and clean water (soft water), refer to "Relationship between concentration of long-life coolant (LLC) and freezing temperature" below for the mixing ratio.

Relationship between concentration of long-life coolant (LLC) and freezing temperature

Freezing temperature	LLC concentration (volume %)
Down to -10 °C (14 °F)	20 %
Down to -15 °C (5 °F)	30 %
Down to -20 °C (-4 °F)	35 %
Down to -25 °C (-13 °F)	40 %

1. Stop the engine, and then allow the radiator to cool.
2. Open the radiator cover.
3. Follow the steps below to drain the coolant.
 - [1] Position a container to drain the coolant into.
 - [2] Remove the drain plug from the radiator.

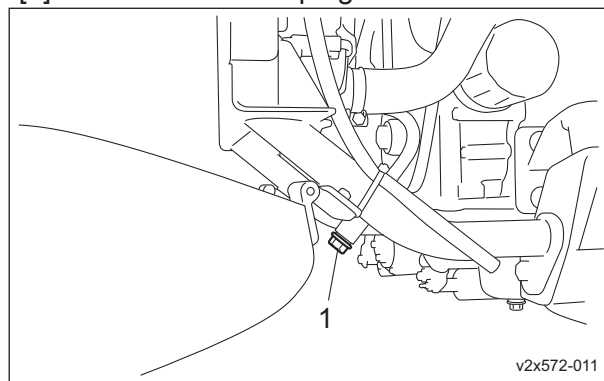

Change of Coolant_001

1	Radiator drain plug
---	---------------------

Maintenance

- [3] Remove the radiator cap and drain the coolant.

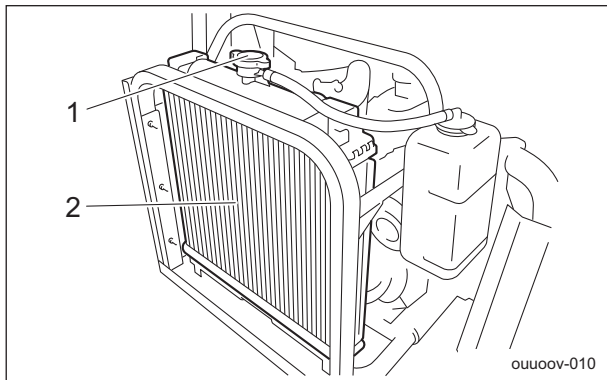

Change of Coolant_002

1	Radiator cap
2	Radiator

- [4] Remove the reserve tank.

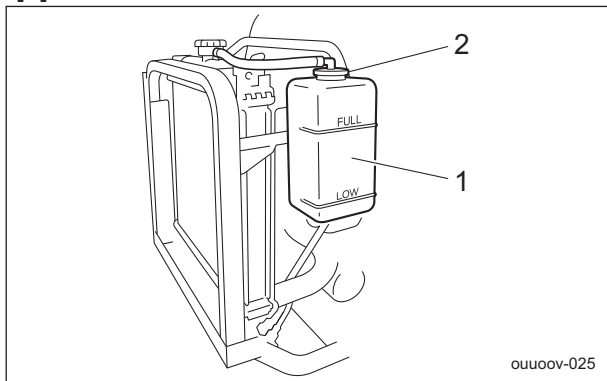

Change of Coolant_003

1	Reserve tank
2	Reserve tank cap

- [5] Open the reserve tank cap, and then drain the coolant.

4. Install the reserve tank.
5. Clean the radiator with clean water to remove any debris or rust.
6. Drain all water from the radiator.
7. Follow the steps below to fill with coolant. The coolant quantity, including the reserve tank, is 3.0 dm³ (3.0 L).
 - [1] Install the drain plug.
 - [2] Supply clean water and antifreeze into the radiator up to the radiator cap opening.
 - [3] Close the radiator cap.
 - [4] Supply clean water and antifreeze into the reserve tank up to the "FULL" mark.
 - [5] Close the reserve tank cap.
8. Start the engine, and then idle for several minutes to bleed air from the system.

9. Stop the engine, and then allow the radiator to cool.
10. Check if the coolant level in the reserve tank is between "FULL" and "LOW", and then supply coolant if necessary.
11. Close the radiator cover.

Change of Hydraulic Oil

⚠ Caution

Be careful with hot oil, which could cause burns if it contacts your skin.

Important

When you change the hydraulic oil, be sure to drain it into a bowl and discard it in accordance with local laws and regulations.

Important

If the oil emulsifies or if it becomes even slightly less transparent, change the oil immediately.

Important

Use Shell Tellus S2M46 (or equivalent) as hydraulic oil.

1. Follow the steps below to remove the old oil.
 - [1] Start and run the engine to warm up the oil.
 - [2] On a level surface, lower the mower units, and then stop the engine.
 - [3] Remove the drain plug of the hydraulic tank, and then drain the old oil into a container.
 - [4] Wind new sealing tape on the drain plug, and then attach it to the hydraulic tank.

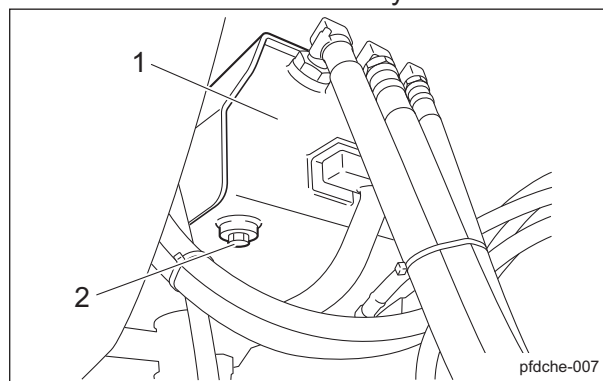

Change of Hydraulic Oil_001

1	Hydraulic tank
2	Drain plug

2. Open the hood.

3. Follow the steps below to fill with new coolant.

The hydraulic tank capacity is approximately 16.0 dm³ (16.0 L).

[1] Open the tank cap, and then pour new oil from the fill port until the oil level reaches the middle of the oil gauge on the hydraulic tank.

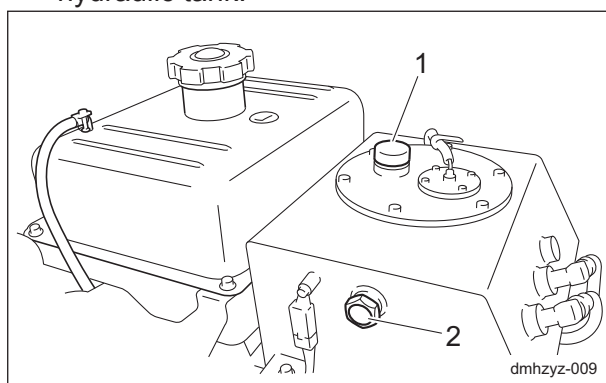

Change of Hydraulic Oil_002

1	Tank cap
2	Oil gauge

[2] Tighten the tank cap securely.

4. Start the engine, raise and lower the mower units, and turn the steering wheel left and right.

Move forward and reverse repeatedly several times.

5. Raise the mower units and maintain that position on a level surface, and then check to see if the oil level is at the middle of the oil gauge. If necessary, supply oil.

6. Check underneath the machine for oil leakage.

7. Close the hood.

Change of Hydraulic Oil Filter

⚠ Caution

Be careful with hot oil, which could cause burns if it contacts your skin.

Important

When replacing the hydraulic oil filter, be sure to drain the oil into a container and discard it in accordance with local laws and regulations.

Important

If the hydraulic oil emulsifies or if it becomes even slightly less transparent, change the oil immediately.

Important

Use Shell Tellus S2M46 (or equivalent) as hydraulic oil.

1. Lower the mower units on a level surface.
2. Stop the engine.
3. Remove the old filter cartridge.

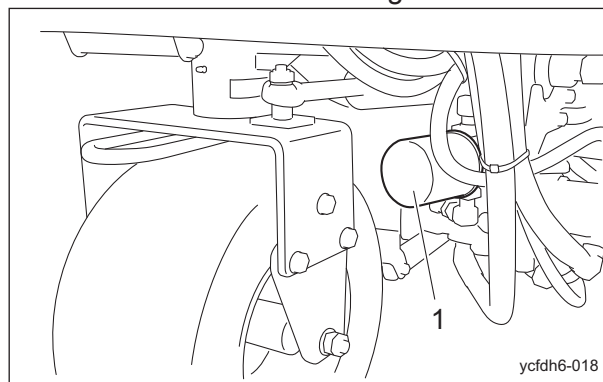

Change of Hydraulic Oil Filter_001

1	Filter cartridge
---	------------------

4. Lightly coat the packing of the new filter cartridge with hydraulic oil, and then install the cartridge.
5. Screw in the filter cartridge by hand until the packing contacts the mounting surface. Then tighten additional 1/2 turn from that point.
6. Supply hydraulic oil until it reaches the specified level.
"Hydraulic Oil Supply" (Page 4-6)
7. Start the engine, and then stop it after 10 to 20 minutes.
8. Make sure that there is no oil leakage at the sealing surface of the filter cartridge.
9. Check the hydraulic oil level.
If it is low, supply hydraulic oil until it reaches the specified level.

Maintenance

10. Check underneath the machine for oil leakage.

Change of Air Cleaner

A contaminated air cleaner element may cause malfunction of the engine.

To maximize the life of the engine, replace the air cleaner element at the appropriate times.

1. The timing for replacing the air cleaner element is described below.
 - [1] Replace the air cleaner element in accordance with the Maintenance Schedule.
 - [2] If it is significantly contaminated, replace it, even if the hours of operation do not exceed the specified time.
2. Replace the air cleaner element by following the same steps as for cleaning the air cleaner.

"Cleaning of Air Cleaner" (Page 4-7)

Change of Engine Oil

Caution

Be careful with hot oil, which could cause burns if it contacts your skin.

Important

When you change the engine oil, be sure to drain it into a bowl and discard it in accordance with local laws and regulations.

Important

Be sure to use engine oil that is classified as API Service Grade CF or higher, with an SAE Viscosity that is appropriate for the operating environment (ambient temperature).

Important

Securely tighten the oil level gauge and oil filler cap.

Change the engine oil more frequently if the engine oil is contaminated and, especially, if you use the machine in dusty areas or operate the engine at high loads or in high temperatures.

1. Follow the steps below to remove the old engine oil.
 - [1] Start and run the engine to warm up the engine oil.
 - [2] With the machine on a level surface, stop the engine.
 - [3] Remove the drain plug, and then drain the old engine oil into a container.

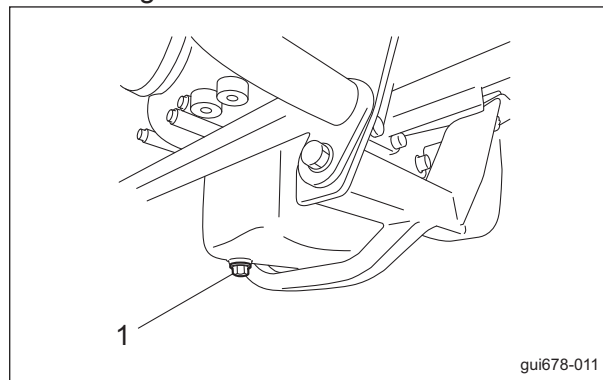

Change of Engine Oil_001

1	Drain plug
---	------------

- [4] Replace the drain plug in the engine.
2. Remove the oil filler cap, and supply new engine oil until the oil reaches a level in between the upper and lower limit lines on the oil level gauge.

Engine oil quantity is approximately 2.8 dm³ (2.8 L).
3. Replace the oil filler cap.

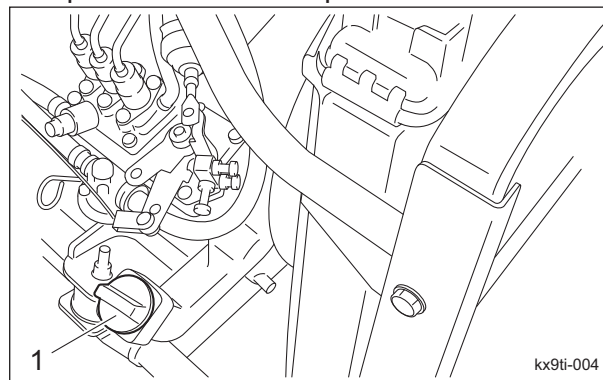

Change of Engine Oil_002

1	Oil filler cap
---	----------------

4. It will take a while for the supplied engine oil to descend into the oil pan.

Check the oil level again 10 to 20 minutes after filling the oil.
5. Check underneath the machine for oil leakage.

Replacement of Engine Oil Filter

⚠ Caution

Be careful with hot oil, which could cause burns if it contacts your skin.

Important

When replacing the engine oil filter, be sure to drain the engine oil into a container and discard it in accordance with local laws and regulations.

Important

Be sure to use engine oil that is classified as API Service Grade CF or higher, with an SAE Viscosity that is appropriate for the operating environment (ambient temperature).

Important

Securely tighten the oil level gauge and oil filler cap.

1. With the filter wrench, remove the old filter cartridge.

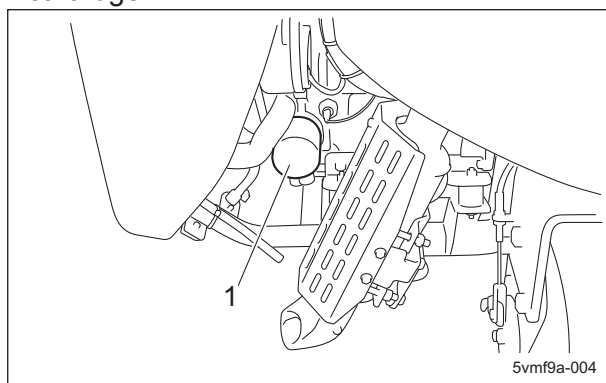

Replacement of Engine Oil Filter_001

1	Filter cartridge
---	------------------

2. Lightly coat the packing of the new filter cartridge with engine oil.
3. Hand-tighten the filter cartridge until the packing contacts the mounting surface, and then hand-tighten additional 1/2 turn.
4. Supply engine oil until it reaches the specified level.
"Supply of Engine Oil" (Page 4-10)
5. Start the engine, and then stop it after 10 to 20 minutes.

6. Make sure that there is no oil leakage at the sealing surface of the filter cartridge.
7. Check the engine oil level.
If it is low, supply engine oil until it reaches the specified level.
8. Check underneath the machine for oil leakage.

Replacement of Fuel Filter Element

If dust or dirt accumulates in the fuel filter, the fuel flow will become insufficient. Replace the fuel filter at the appropriate times. The fuel filter is on the left side under the fuel tank.

1. Close the fuel cock of the fuel filter.

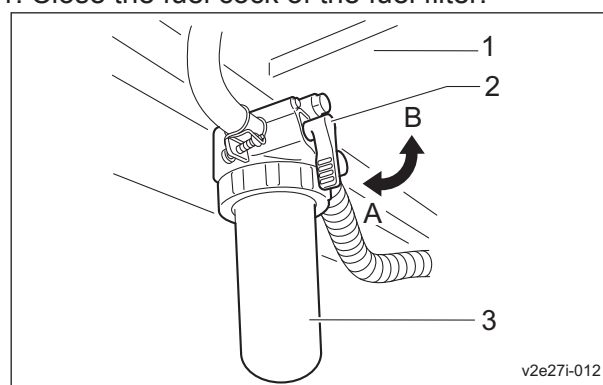

Replacement of Fuel Filter Element_001

1	Fuel tank
2	Fuel cock
3	Fuel filter
A	ON (open)
B	OFF (close)

Maintenance

2. Remove the ring nut, and then remove the cup.

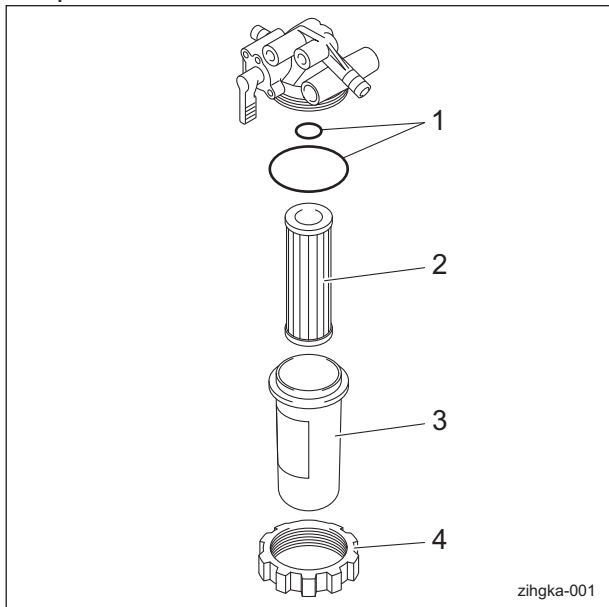

Replacement of Fuel Filter Element_002

1	O-ring
2	Element
3	Cup
4	Ring nut

3. Clean the inside of the filter cup with diesel fuel.

Important

While installing the fuel filter, prevent contamination with dirt or dust. The fuel contaminated with dirt or dust will cause engine failure.

4. Install a new fuel filter element, and then correctly install all parts in their original positions.

5. Fill up the fuel tank with fuel, and then open the fuel cock.

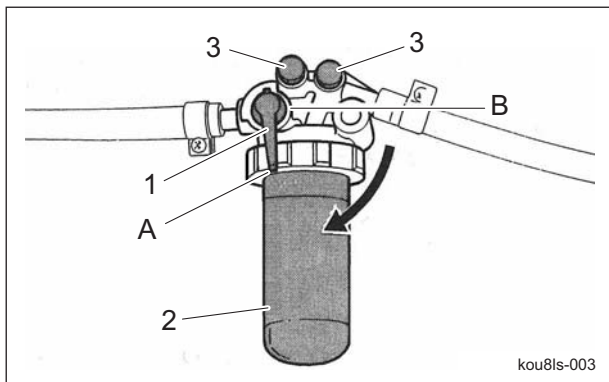

Replacement of Fuel Filter Element_003

1	Fuel cock
2	Fuel filter
3	Air-bleeding plug
A	ON (open)
B	OFF (close)

6. Remove air out of the fuel.

Grease Change of Transmission

The transmission is located behind the driver's seat.

Change grease every two years.

Grease type	Pyronoc CC1
Grease quantity	400 g

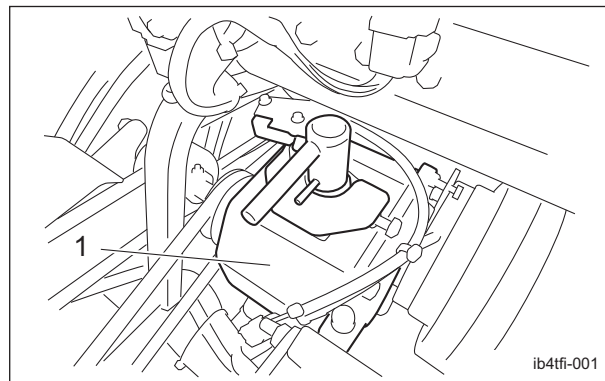

Grease Change of Transmission_001

1	Transmission
---	--------------

Change of Fuse

Fuse Box

Important

Before performing maintenance on the electrical system, be sure to disconnect the negative terminal of the battery.

Important

If a fuse is blown, the electrical circuit may be shorted.
Check to identify the cause, such as a bad terminal connection, damaged wiring or terminals, or incorrect wiring.

The fuse box includes spare fuses and tools.

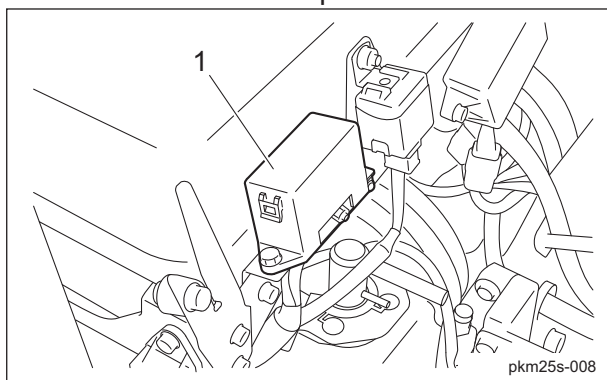

Fuse Box_001

1	Fuse box
---	----------

The machine uses a mini fuse for automobiles.
Replace an old fuse with a new fuse of the specified capacity.

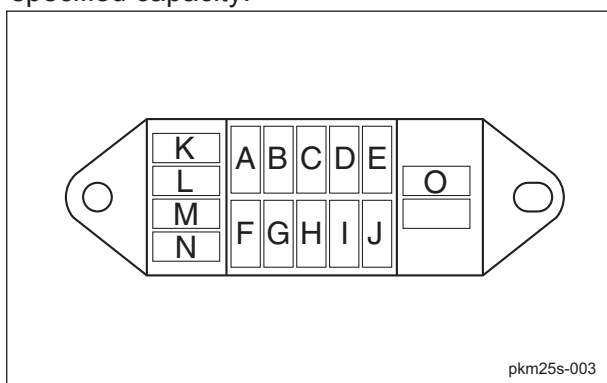

Fuse Box_002

A	5 A	Glow lamp timer
B	5 A	Key stop timer
C	5 A	Glow lamp timer, glow lamp (thermo-start lamp)
D	-	-
E	-	-
F	15 A	Engine stop solenoid
G	15 A	Others
H	5 A	Water temperature gauge, regulator
I	-	-
J	-	-
K	5 A	Spare
L	5 A	
M	15 A	
N	15 A	
O	Fuse removal tool	

Fusible Link

Fuse capacity of the fusible link is 50A.

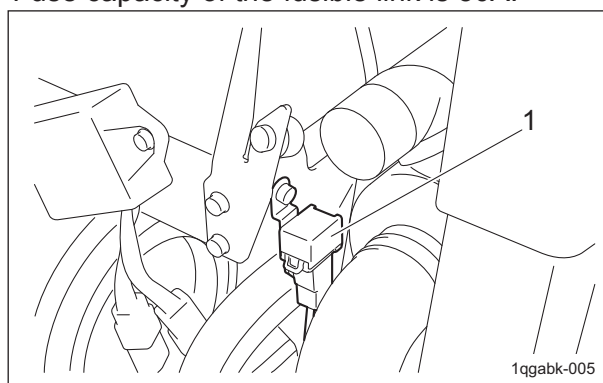

Fusible Link_001

1	Fusible link
---	--------------

Maintenance

Check The Operation Status of The Relay

Mower Unit Control Relay

The relay box is located behind the seat. This controls Up/Down of the mower unit and Rotate/Stop of the reel cutter (cutting cylinder). The operating condition can be checked by the illumination of the LEDs.

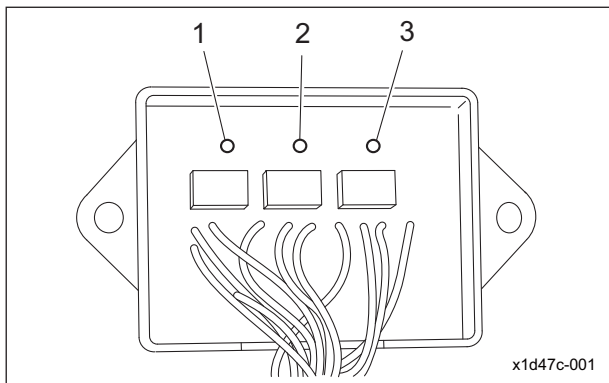

Mower Unit Control Relay_001

Refer to the table below to check the LED status.

		Condition	LED status
1	Front right up/down cylinder (Reel rotation)	Down	ON
		Up	OFF
2	Center mower up/down cylinder (Before pressing Raise/Lower switch)	Up	ON
		Down	OFF
3	Center mower up/down cylinder (After pressing Raise/Lower switch)	Down	ON
		Up	OFF

Interlock Relay

The relay box is located under the underseat cover.

This controls a safety device for starting/stopping the engine.

The operating condition can be checked by the illumination of the LEDs.

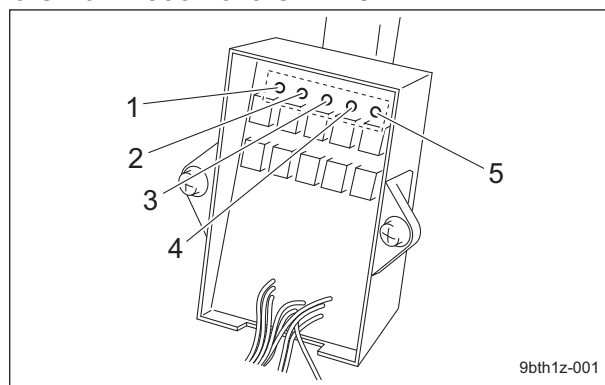

Interlock Relay_001

Refer to the table below to check the LED status.

		Condition	LED status
1	Traveling pedal switch	Neutral	ON
		Depress	OFF
2	Parking brake switch	Pull	ON
		Release	OFF
3	Seat switch	Away	ON
		Seated	OFF
4	Reel rotation switch	ON	ON
		OFF	OFF
5	Transmission selector lever	LAP	ON
		H	OFF
		L	OFF

Removal of Mower Unit

1. Remove the clip which fixes the mower unit and flexible wire.

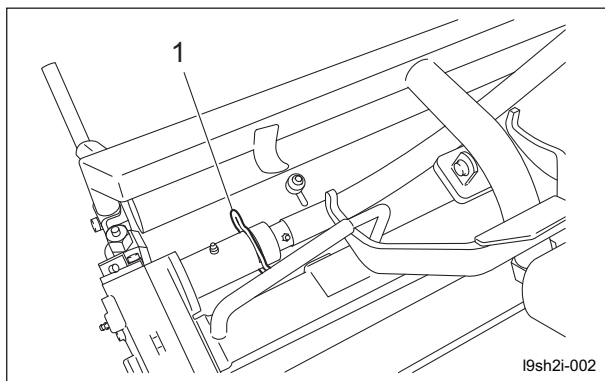

Removal of Mower Unit_001

1	Clip
---	------

2. Slide the stopper of the mower attaching pipe forward and pull it out.
3. Pull out the mower unit and remove it.

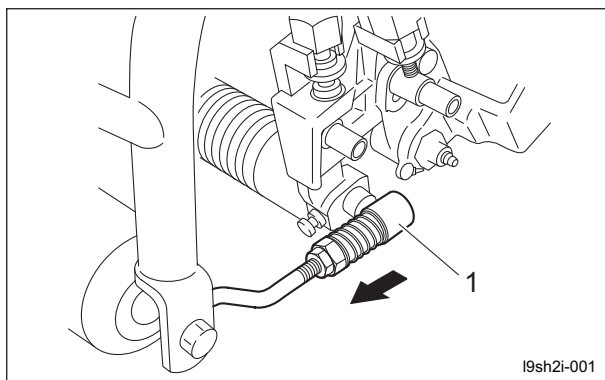

Removal of Mower Unit_002

1	Stopper (right/left)
---	----------------------

Note:
For installing the mower unit, reverse the removing procedure.

Maintenance

EU Declaration of Conformity

Product Identification

Product : Lawnmower
Brand-Name : BARONESS
Type : LM315
Version(s) : GC
Starting Serial No. : **31228**
Measured Sound Power Level : LWA 102.40 dB
Guaranteed Sound Power Level : LWA 103 dB
Manufacturer Name : Kyoeshisa Co., Ltd.
Address : 1-26 Miyuki-cho, Toyokawa, Aichi-pref., Japan

Conforms to the following Directives

2006/42/EC Machinery (MD)
2014/30/EU Electromagnetic compatibility (EMC)
2000/14/EC Noise emissions from outdoor equipment

We have been designed and manufactured under the following specifications

ISO 12100 : 2010 (2006/42/EC)
ISO 5395-1 : 2013 (2006/42/EC)
ISO 5395-3 : 2013 (2006/42/EC)
ISO 14982 : 1998 (2014/30/EU)

Keeper of Technical Documentation

Name : Kyoeshisa Co., Ltd.
Address : 1-26 Miyuki-cho, Toyokawa, Aichi-pref., Japan

Compiler of the technical file (2006/42/EC)

Name : Kyoeshisa U.K.Ltd.
Address : Unit 5 Hatch Industrial Park Grewell Road, Basingstoke Hampshire RG24 7NG, the United Kingdom

Conformity assessment procedures

Internal production control : Module A (2006/42/EC)
EC-type examination : Module B (2014/30/EU)
Internal control of production with assessment of technical documentation and periodical checking (2000/14/EC)

Involved Notified Body (2000/14/EC)

Name : TÜV SÜD Industrie Service GmbH
Address : Westendstraße 199 80686 München
Certificate : Notified Body NB0036 according 2000/14/EC

Place : Japan
Date : 1 June 2020 (1 / 6 / 2020)

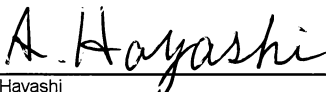
Signature : 
Name : Akio Hayashi
Position : Quality Dept. Director

(fr)

Déclaration de conformité UE

Identification du produit

Produit : Tondeuse à gazon
Fabriquant : BARONESS
Type : LM315
Version(s) : GC
Numéro de série de début : **31228**
Niveau de puissance acoustique mesuré : LwA 102.40 dB
Niveau de puissance acoustique garanti : LwA 103 dB
Fabricant Nom : Kyoeshisa Co., Ltd.
Adresse : 1-26, Miyuki-cho, Toyokawa, préfecture d'Aichi, Japon

Conforme aux directives suivantes :

2006/42/CE Machine (MD)
2014/30/UE Compatibilité électromagnétique (CEM)
2000/14/CE Émissions sonores de l'équipement de plein air

Conception et fabrication en respect des spécifications suivantes :

ISO 12100 : 2010 (2006/42/CE)
ISO 5395-1 : 2013 (2006/42/CE)
ISO 5395-3 : 2013 (2006/42/CE)
ISO 14982 : 1998 (2014/30/UE)

Fiche technique

Marque : Kyoeshisa Co., Ltd.
Adresse de la marque : 1-26, Miyuki-cho, Toyokawa, préfecture d'Aichi, Japon

Compilateur de la fiche technique (2006/42/CE)

Nom : Kyoeshisa U.K. Ltd.
Adresse : Unit 5 Hatch Industrial Park Greywell Road, Basingstoke Hampshire RG24 7NG, Royaume-Uni

Procédures d'évaluation de la conformité

Contrôle de production interne : module A (2006/42/CE)
Examen de type CE : module B (2014/30/UE)
Contrôle interne de la production avec évaluation de la fiche technique et vérification périodique (2000/14/CE)

Organisme notifié impliqué (2000/14/CE)

Nom : TÜV SÜD Industrie Service GmbH
Adresse : Westendstraße 199 80686 München / Munich Deutschland / Germany
N° de certificat : Notified Body NB0036 according 2000/14/EC

Declaración de conformidad de la UE

Identificación del producto

Producto: Cortacésped
 Marca: BARONESS
 Tipo: LM315
 Versión: GC
 N.º de serie inicial: **31228**
 Nivel de potencia sonora medido: LWA 102.40 dB
 Nivel de potencia sonora garantizado: LWA 103 dB
 Fabricante Nombre: Kyoeshia Co., Ltd.
 Dirección: 1-26 Miyuki-cho, Toyokawa, Aichi-pref., Japón

Cumple las siguientes Directivas

2006/42/CE Maquinaria (MD)
 2014/30/UE Compatibilidad electromagnética (EMC)
 2000/14/CE Emisiones sonoras de máquinas de uso al aire libre

Se ha diseñado y fabricado utilizando las siguientes especificaciones

ISO 12100 : 2010 (2006/42/CE)
 ISO 5395-1 : 2013 (2006/42/CE)
 ISO 5395-3 : 2013 (2006/42/CE)
 ISO 14982 :1998 (2014/30/UE)

Documentación técnica

Nombre del responsable: Kyoeshia Co., Ltd.
 Dirección del responsable: 1-26 Miyuki-cho, Toyokawa, Aichi-pref., Japón

Compilador del archivo técnico (2006/42/CE)

Nombre: Kyoeshia U.K. Ltd.
 Dirección: Unit 5 Hatch Industrial Park Greywell Road, Basingstoke Hampshire RG24 7NG, Reino Unido

Procedimientos de evaluación de conformidad

Control de fabricación interno: Módulo A (2006/42/CE)
 Examen de tipo CE: Módulo B (2014/30/UE)
 Control interno de fabricación con evaluación de documentación técnica y comprobaciones periódicas (2000/14/CE)

Organismo notificado implicado (2000/14/CE)

Nombre: TÜV SÜD Industrie Service GmbH
 Dirección: Westendstraße 199 80686 München / Munich Deutschland / Germany
 Certificado: Notified Body NB0036 according 2000/14/EC

EU-Konformitätserklärung

Produktbeschreibung

Produkt: Rasenmäher
 Marke: BARONESS
 Modell: LM315
 Version(en): GC
 Startseriennummer: **31228**
 Gemessener Schalleistungspegel: LWA 102.40 dB
 Garantiertes Schalleistungspegel: LWA 103 dB
 Hersteller Name: Kyoeshia Co., Ltd.
 Adresse: 1-26 Miyuki-cho, Toyokawa, Aichi-pref., Japan

Entspricht den folgenden Richtlinien

2006/42/EG Maschinenrichtlinie
 2014/30/EU Elektromagnetische Verträglichkeit (EMV)
 2000/14/EG Geräuschemission von im Freien betriebenen Geräten

Unter Anwendung der folgenden Bestimmungen entwickelt und hergestellt

ISO 12100 : 2010 (2006/42/EG)
 ISO 5395-1 : 2013 (2006/42/EG)
 ISO 5395-3 : 2013 (2006/42/EG)
 ISO 14982 :1998 2014/30/EU)

Technische Dokumentation

Name des Halters: Kyoeshia Co., Ltd.
 Adresse des Halters: 1-26 Miyuki-cho, Toyokawa, Aichi-pref., Japan

Technische Unterlagen erstellt von (2006/42/EG)

Name: Kyoeshia U.K. Ltd.
 Adresse: Unit 5 Hatch Industrial Park Greywell Road, Basingstoke Hampshire RG24 7NG, Großbritannien

Konformitätsbewertungsverfahren

Interne Produktionskontrolle : Modul A (2006/42/EG)
 EG-Baumusterprüfung : Modul B (2014/30/EU)
 Interne Produktionskontrolle mit Bewertung der technischen Unterlagen und regelmäßiger Überprüfung (2000/14/EG)

Beteiligte benannte Stelle (2000/14/EG)

Name: TÜV SÜD Industrie Service GmbH
 Adresse : Westendstraße 199 80686 München / Munich Deutschland / Germany
 Bescheinigung. : Notified Body NB0036 according 2000/14/EC

EU-försäkran om överensstämmelse

Produktidentifikation

Produkt : Gräsklippare
Märke: BARONESS
Typ: LM315
Version(er): GC
Serienummer startar på: **31228**
Uppmätt ljudeffektnivå: LWA 102.40 dB
Garanterad ljudeffektnivå: LWA 103 dB
Tillverkare Namn: Kyoisha Co., Ltd.
Adress: 1-26 Miyuki-cho, Toyokawa, Aichi-pref., Japan

Uppfyller följande direktiv

2006/42/EG Maskindirektivet
2014/30/EU Elektromagnetisk kompatibilitet (EMC)
2000/14/EG Bulleremission från utomhusutrustning

Följande kravspecifikationer har följts vid konstruktion och tillverkning

ISO 12100 : 2010 (2006/42/EG)
ISO 5395-1 : 2013 (2006/42/EG)
ISO 5395-3 : 2013 (2006/42/EG)
ISO 14982 : 1998 (2014/30/EU)

Teknisk dokumentation

Innehavarens namn: Kyoisha Co., Ltd.
Innehavarens adress: 1-26 Miyuki-cho, Toyokawa, Aichi-pref., Japan

Den tekniska filen(2006/42/EG) har tagits fram av

Namn: Kyoisha U.K.Ltd.
Adress: Unit 5 Hatch Industrial Park Grewell Road, Basingstoke Hampshire RG24 7NG, Storbritannien

Förfarande för bedömning av överensstämmelse

Intern produktionskontroll: Modul A (2006/42/EG)
EG-typprovning: Modul B (2014/30/EU)
Intern kontroll av produktion med fastställande av teknisk dokumentation och periodiska kontroller (2000/14/EG)

Anmält organ (2000/14/EG)

Namn: TÜV SÜD Industrie Service GmbH
Adress: Westendstraße 199 80686 München / Munich Deutschland / Germany
Certifikat : Notified Body NB0036 according 2000/14/EC

BARONESS[®]
Quality on Demand

 **KYOEISHA CO., LTD.**
Head Office 1-26, Miyuki-cho, Toyokawa-city, Tel :+81-533-84-1390
Aichi-pref, 442-8530 JAPAN Fax:+81-533-84-1220