

GREEN MOWER

***LM56GA***  
***LM66TA***

**BARONNESS**  
**LAWN MOWER**

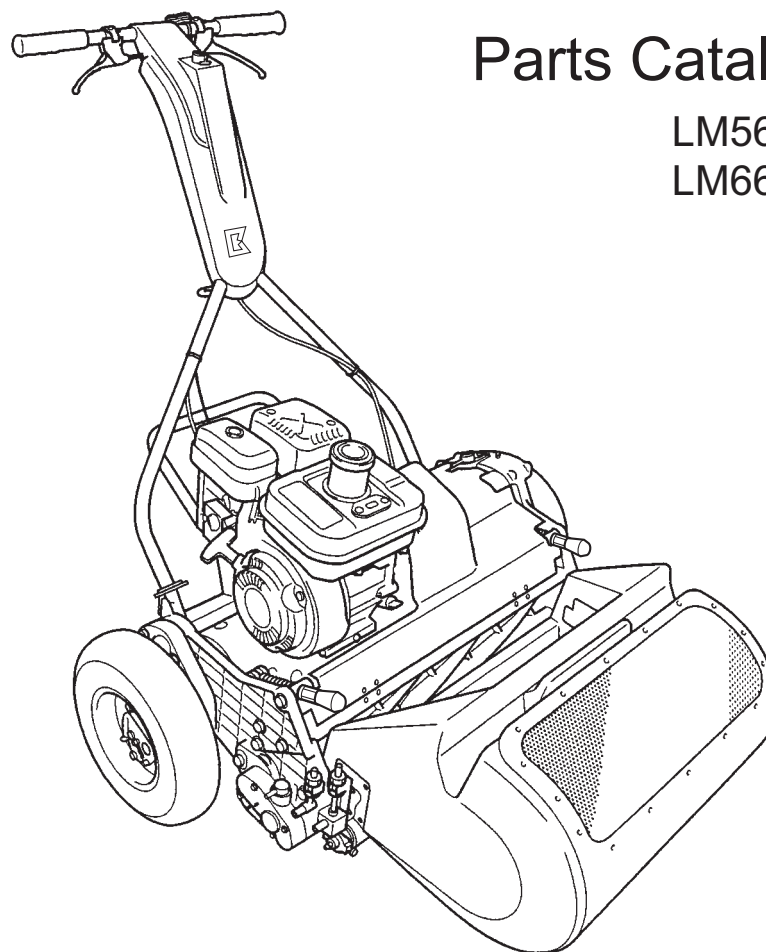

Parts Catalogue (The second edition)

LM56GA SN 14723 and onwards

LM66TA SN 10045 and onwards

**BARONNESS**

# Contents

PARTS CATALOGUE .....	2
1. Blade reel cylinder/bottom blade .....	3
2. Front roller (Without independent arm) .....	7
3. Front roller (For independent arm) .....	9
4. Drum wheel .....	11
5. Clutch .....	13
6. Frame transmission .....	15
7. Handle/engine/brake .....	19
8. Groomer .....	21
9. Brush .....	25
10. Grass catcher/tool .....	27
11. Independent arm grass catcher .....	29
12. Maintenance supplies.....	31

GREEN MOWER

***LM56GA***

***LM66TA***

**BARONESS**

**LAWN MOWER**

## PARTS CATALOGUE

☆ **Ordering parts**

All parts in this parts catalogue are controlled by computer.

For prevention of delivery of wrong parts, advise us of the catalogue No., code No., and part name.

(Example)	Cat No.	Code No.	Part Name	Qty
	1-1	LM56GA-0506Z2	blade adjusting nut	2



Cat No.	Code No.	Part Name	Qty		Remark
			LM56	LM66	
1-1	LM56GA-0506Z2	blade adjusting nut	2	2	
1-2	K5000100002	10 washer	4	4	
1-3	K6500000102	5 SS41 metal washer 10.522	4	4	
1-4					
1-5	LM56GA-0509Z2	support metal	2	2	
1-6	LM56G--0504Z2	spring adjusting screw	2	2	
1-7	K0160000582	14 nut 3P1.25	2	2	
1-8	K1000000458	5 compression spring 2560	2	2	
1-9	K6206000052	spring receiver	2	2	
1-10	K1310000150	rubber cap 14	2	2	
1-11	LM56GA-0503A2	bottom blade mount arm	2	2	
1-12	K6511000082	cutter adjusting bolt 140	2	2	
1-13	LM56GA-2601Z0	bottom blade mount COMP3	1	0	
1-14	LM66TA-0501Z0	bottom blade mount COMP5	0	1	
1-15	LM56GA-0501ZR	bottom blade mount	1	0	
1-16	LM66GA-0501ZR	bottom blade mount	0	1	
1-17	K2511000270	1.5 bottom blade 55G	1	0	
1-18	K2510000150	3 bottom blade 62.5-648.4	0	1	
1-19	K0071000222	6 heat-treated countersunk head screw 12	13	15	
1-20	K6082000010	cutter pin R	2	2	
1-21	K0160000112	locknut	2	2	
1-22	K6010000010	cam bushing	2	2	
1-23	K5073208202	3.2 SPHC metal washer 820	2	2	
1-24	K0200080002	8S washer	6	6	
1-25	K0000080152	8 bolt 15	4	4	
1-26	K0100080002	8 nut	1	1	
1-27					
1-28	K690200005D	cover	1	1	
1-29	K5000080002	8 washer	4	4	
1-30	K0000080502	8 bolt 50	1	1	
1-31	K0882045000	O-ring G45	1	1	
1-32	LM56G--1208A0	reel gear fixing nut	1	1	
1-33					
1-34	LM56G--1204Z0	20 reel gear	1	1	
1-35	K1000000740	3.2 compression spring 26.922	1	1	

Cat No.	Code No.	Part Name	Qty		Remark
			LM56	LM66	
1-36	K0631302040	taper roller 30204JRP6	2	2	
1-37	K0053080202	8 conical head bolt with hex. hole 20	3	3	
1-38	K0830000020	oil seal 254210	2	2	
1-39	K280561090R	reel cutter 557-9	1	0	
1-40	K280661090R	reel cutter 646-9	0	1	
1-41	K280561010R	reel cutter 557-11	1	0	
1-42	K280661010R	reel cutter 646-11	0	1	
1-43	K6213000040	bearing collar (L)	1	1	
1-44	K5300000282	pin stopper cover	1	1	
1-45	K0311045250	4.5 needle roller 25.8	1	1	
1-46	LM56G--0105A0	33 reel gear	1	0	
1-47	LM56G--0109Z8	gear support collar	1	1	
1-48	K6032000062	10 flat-head pin 32	2	2	
1-49	K0400008002	stop ring E8	2	2	
1-50	LM56GA-0510Z2	wind arrangement board 560	1	0	
1-51	LM66GA-0510Z2	wind arrangement board 650	0	1	
1-52	LM56GA-0502ZR	reel cover	1	0	
1-53	LM66GA-0502ZR	reel cover	0	1	
1-54	K0000060102	6 bolt 10	2	2	
1-55	K0200060002	6S washer	2	2	
1-56	LM56G--0521ZR	reel cover support	1	0	
1-57	LM66G--0521ZR	reel cover support	0	1	
1-58	LM56G--0606Z2	right reel housing	1	1	
1-59	K0144060002	6U nut	2	2	
1-60	K5011606202	1.6 SPCC metal washer 620	4	4	
1-61	K1000000309	1.6 compression spring 13.720	2	2	
1-62	K6000000540	23SUS bushing 2515	2	2	
1-63	K280661070R	reel cutter 646-7	0	1	
1-64	K2511000280	2 bottom blade 55G	1	0	
1-65	K2511000300	2 bottom blade 65G	0	1	
1-66	K2511000310	1.5 bottom blade 65G	0	1	
1-67	K2511000050	2.5 bottom blade 55G	1	0	
1-68	K2510000060	3.0 bottom blade 62.5-559	1	0	
1-69	K2511000200	2.5 bottom blade 65G	0	1	
1-70	K2510000170	5 bottom blade 62.5-648.4	0	1	

# 1. Blade reel cylinder/bottom blade

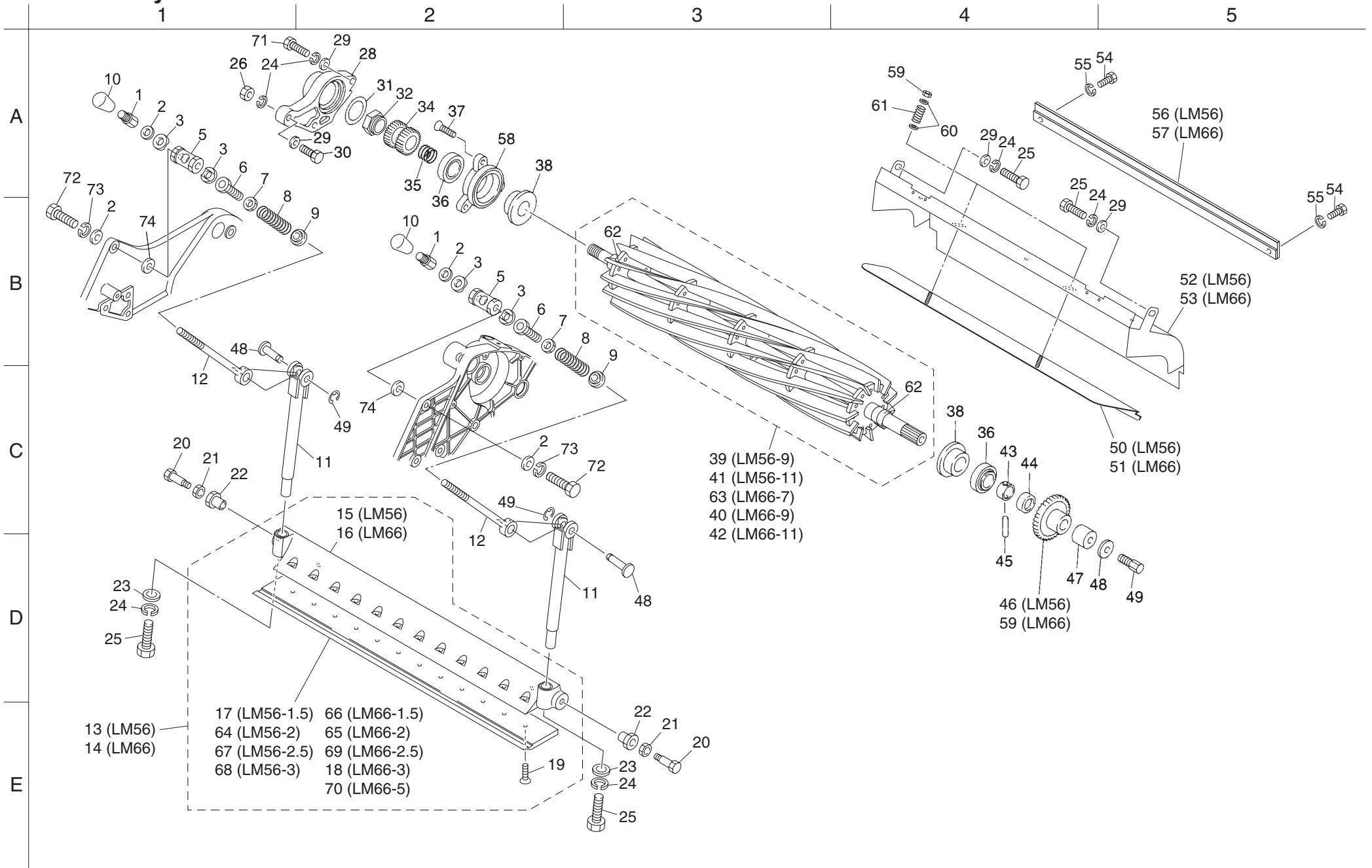

Cat No.	Code No.	Part Name	Qty		Remark
			LM56	LM66	
1-71	K0000080252	8 bolt 25	1	1	
1-72	K0000100302	10 bolt 30	2	2	
1-73	K0200100002	10S washer	2	2	
1-74	K5010412202	0.4 SPCC metal washer 1220	0~6	0~6	

Cat No.	Code No.	Part Name	Qty		Remark
			LM56	LM66	

2. Front roller (Without independent arm)

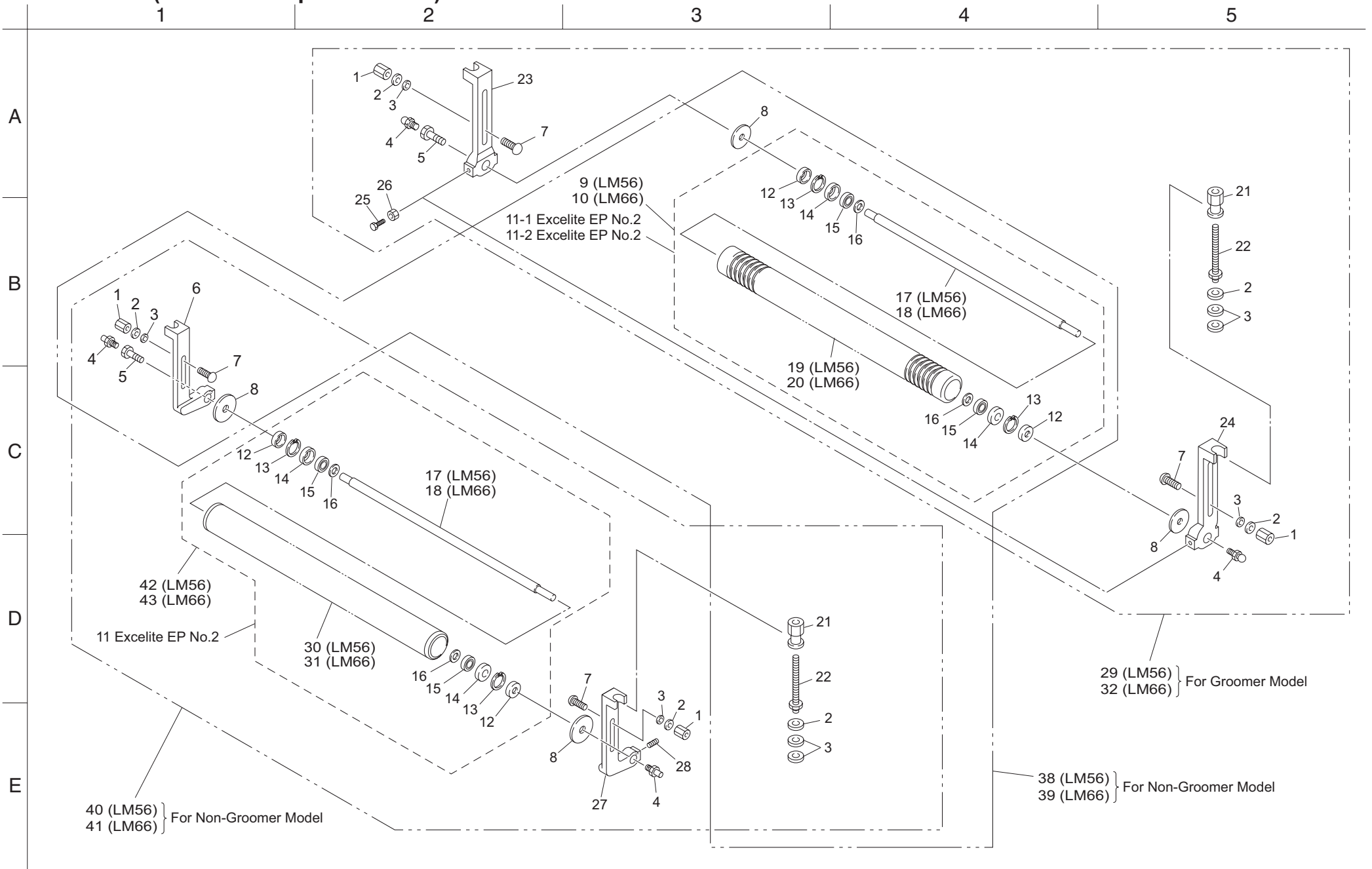









4. Drum wheel

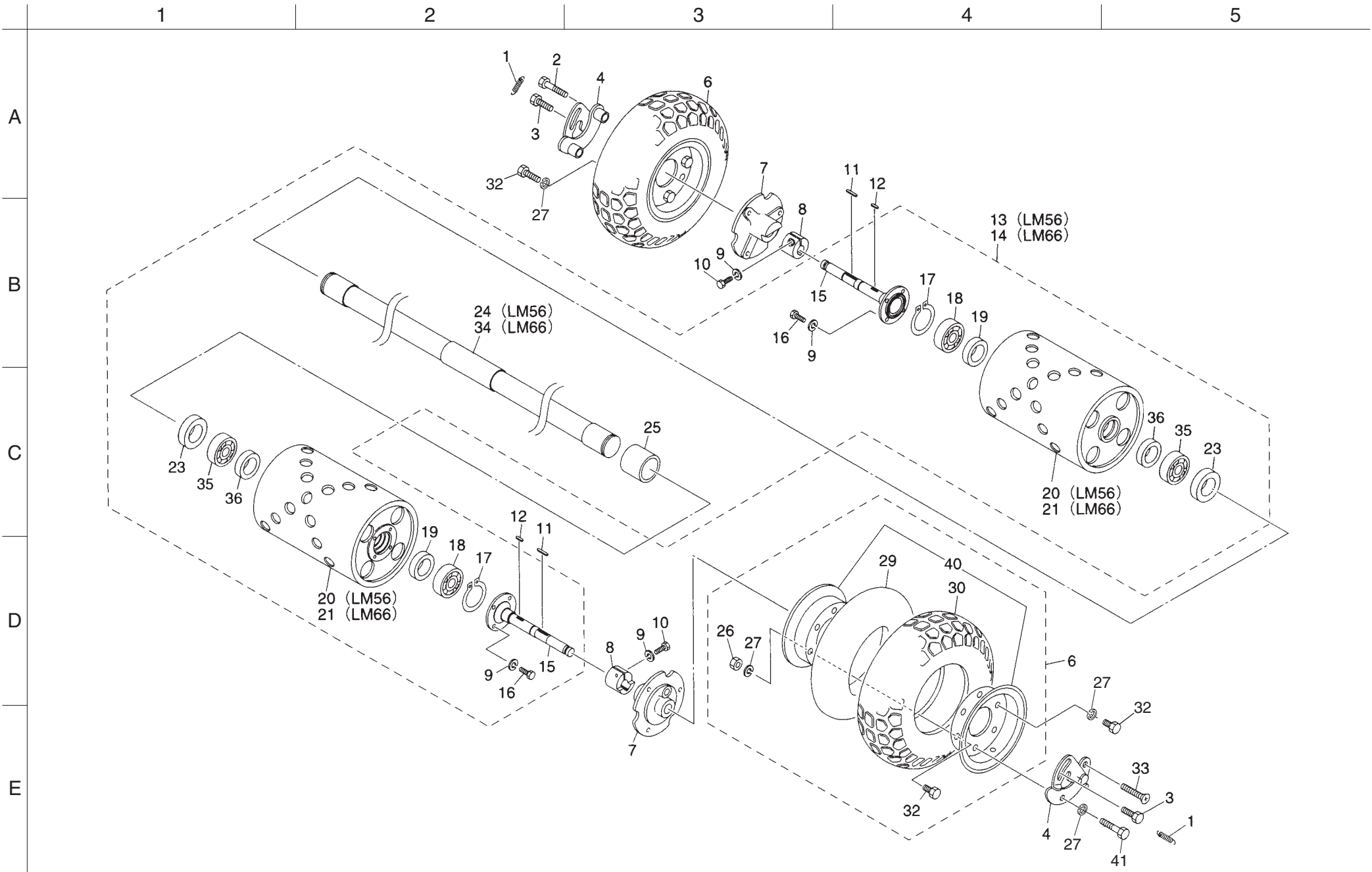



5. Clutch

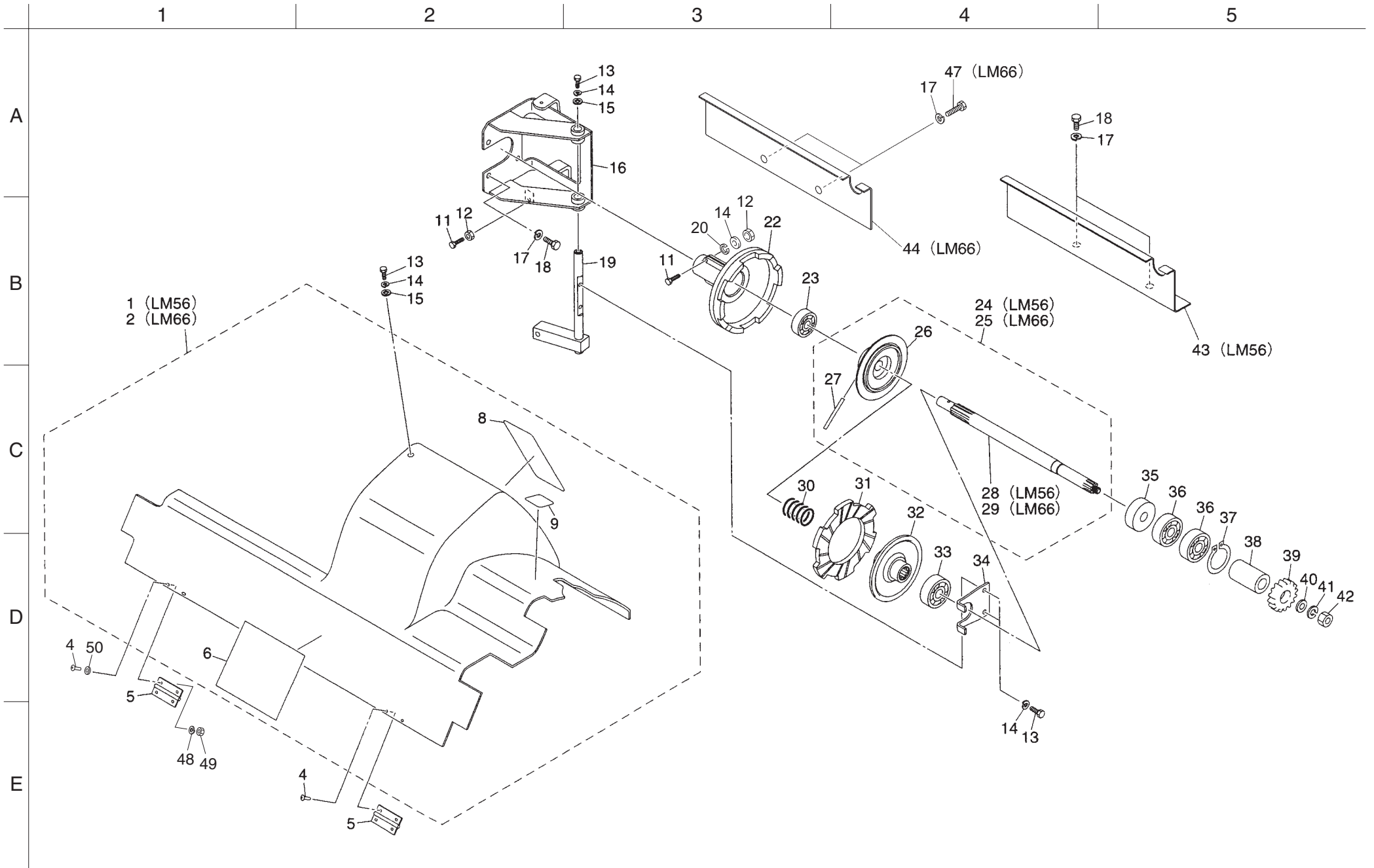



6. Frame transmission

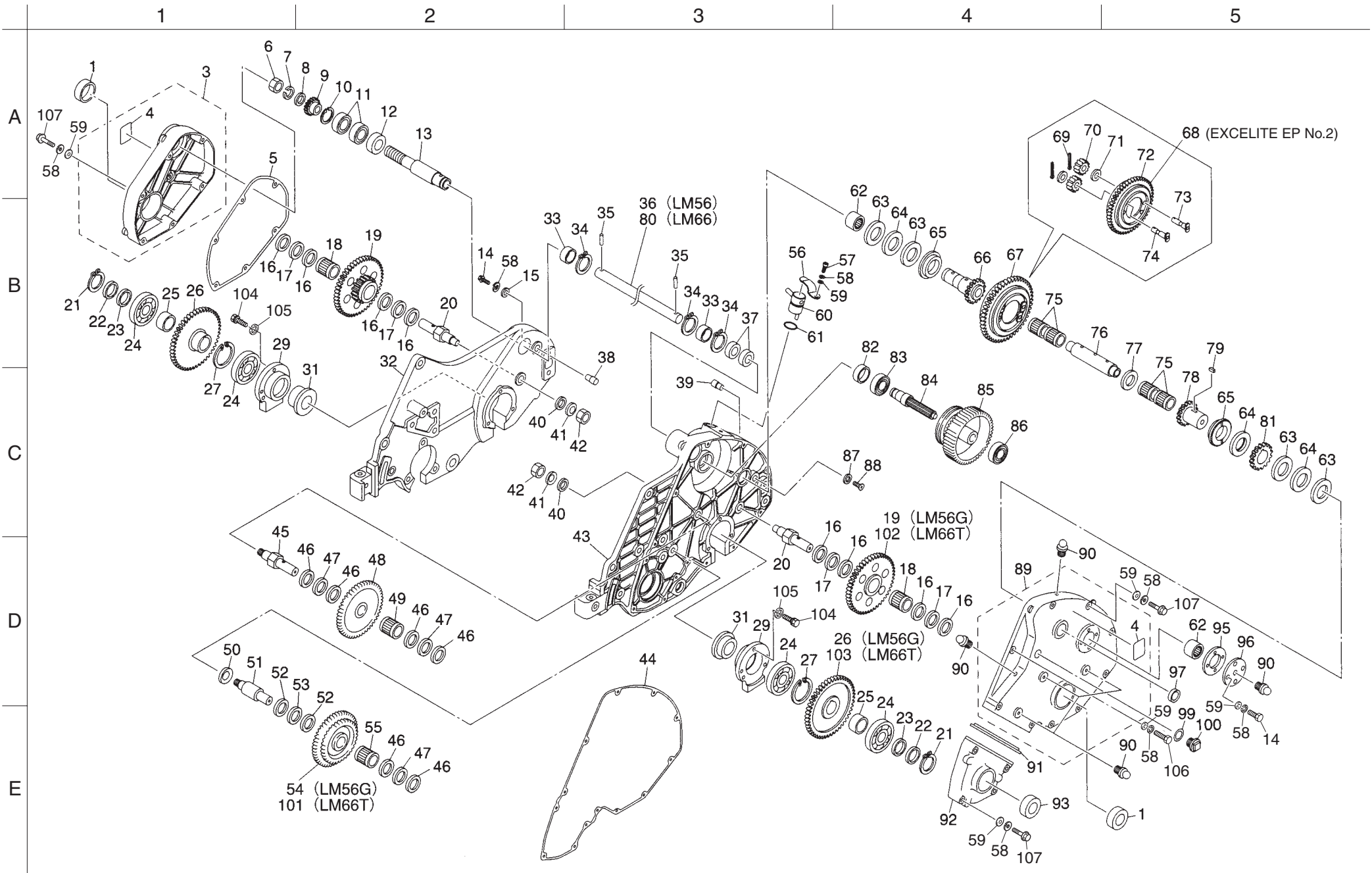



Cat No.	Code No.	Part Name	Qty		Remark
			LM56	LM66	
6-1	K0822047060	oil seal MHSA20476	2	2	
6-2					
6-3	LM56G--0613Z0	right cover with mark	1	1	
6-4	K4209000370	grease after 10 hours mark	2	2	
6-5	LM56G--0609Z0	packing (R)	1	1	
6-6	K0183140002	14 left-hand thread nut P1.5	1	1	
6-7	K0210140002	14 conicak disk spring L	1	1	
6-8	K5000140002	14 washer	1	1	
6-9	K6188000010	18 gear with screw M2	1	1	
6-10	K0402035001	stop ring R35	1	1	
6-11	K0616062020	bearing 62022NSEC3	2	2	
6-12	K0802030050	oil seal MH20305	1	1	
6-13	K6122000188	transmission shaft (R)	1	1	
6-14	K0000060152	6 bolt 15	5	5	
6-15	K5012306202	2.3 SPCC metal washer 620	1	1	
6-16	K5051013220	1C5191P metal washer 1322	8	8	
6-17	K5020813220	0.8NBS55 metal washer 1322	4	4	
6-18	K0711317200	needle KTW131720F01C3	2	2	
6-19	LM55GB-0219C0	46/16 gear	2	0	
6-20	LM56G--0204Z0	4th shaft (drum side)	2	2	
6-21	K0401020001	stop ring S20	2	2	
6-22	K5010320282	0.3 SPCC metal washer 2028	2	2	
6-23	K5011020282	1 SPCC metal washer 2028	2	2	
6-24	K0601062040	bearing 6204C3	4	4	
6-25	LM55GB-0234A0	collar (L)	2	2	
6-26	LM55GB-0221C0	46 wheel shaft gear	2	0	
6-27	K0402047001	stop ring R47	2	2	
6-28					
6-29	LM56G--0615Z0	gear (interchangeable with -0615A0)	2	2	
6-30					
6-31	K0830000020	oil seal 254210	2	2	
6-32	LM56G--0602BR	frame (R)	1	1	
6-33	LM55GB-0224Z2	differential joint shaft collar	2	2	
6-34	K0403018001	stop ring round S18	3	3	
6-35	K0311040170	4 needle roller 17.8	2	2	

Cat No.	Code No.	Part Name	Qty		Remark
			LM56	LM66	
6-36	LM56G--0205Z8	transmission shaft	1	0	
6-37	K0870182640	seal for needle OS18264	2	2	
6-38	K6155000042	handle mount pin (R)	1	1	
6-39	K6155000152	handle mount pin (L)	1	1	
6-40	K5000100002	10 washer	3	3	
6-41	K0211100001	10 conical disk spring H	3	3	
6-42	K0160000282	10 nut 3P1OH1	3	3	
6-43	LM56G--0601BR	frame (L)	1	1	
6-44	LM56G--0608Z0	packing (L)	1	1	
6-45	LM55GB-0201A0	2nd shaft	1	1	
6-46	K5051013280	1C5191P metal washer 1328	6	6	
6-47	K5020813280	0.8NBS55 metal washer 1328	3	3	
6-48	LM56G--0103A0	46 gear	1	1	
6-49	K0701317120	needle KT131712	1	1	
6-50	K0211120002	12 conical disk spring H	1	1	
6-51	LM55GC-0102Z0	reel intermediate shaft	1	1	
6-52	K5051015280	1C5191P metal washer 1528	2	2	
6-53	K5020815280	0.8NBS55 metal washer 1528	1	1	
6-54	LM56G--0104B0	36/45 gear	1	0	
6-55	K0701519180	needle KT151918	1	1	
6-56	K1090000058	clutch support spring	1	1	
6-57	K0000060102	6 bolt 10	1	1	
6-58	K0200060002	6S washer	25	25	
6-59	K5000060002	6 washer	24	24	
6-60	LM56G--0206Z8	clutch changeover lever	1	1	
6-61	K0880021000	O-ring P21	1	1	
6-62	K0722210000	needle TA2210Z	2	2	
6-63	K5051022300	1C5191P metal washer 2230	4	4	
6-64	K5020822300	0.8NBS55 metal washer 2230	3	3	
6-65	K6202000140	differential gear shaft receiver	2	2	
6-66	LM55GB-0210A3	16 differential gear (R)	1	1	
6-67	K8000000030	50 differential gear ASS'Y	1	1	
6-68-1	K2931000400	Excelite EP No.2 400mL	—	—	use 50g
6-68-2	K2931018000	Excelite EP No.2 18kg can	—	—	use 50g
6-69	K0300025202	2.5 split pin 20	4	4	
6-70	K6191000040	differential pinion gear 12	4	4	

6. Frame transmission

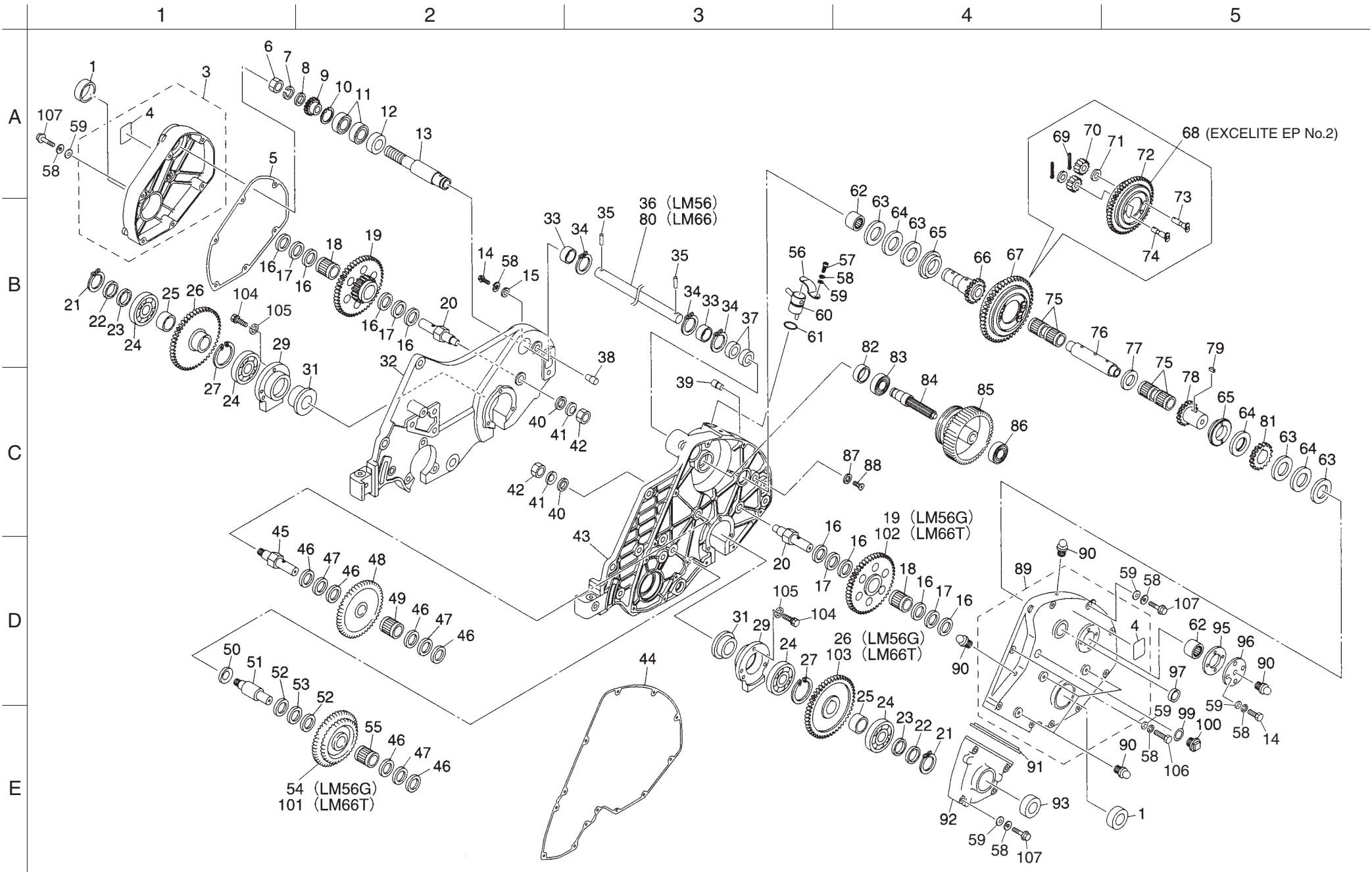





Cat No.	Code No.	Part Name	Qty		Remark
			LM56	LM66	
7-1					
7-2	K2620000370	Robin EX130D70060	1	1	
7-3	K3620000550	engine switch cord 8A	1	1	
7-4					
7-5	K6810000060	engine base M	1	1	
7-6	K0000100352	10 bolt 35	6	6	
7-7	K0213100002	10 metal washer with conical disk washer 1H	14	14	
7-8	K5000100002	10 washer	16	16	
7-9	LM56G--0706ZR	front frame stay	1	1	
7-10	LM66G--0706AR	front frame stay	0	0	
7-11	K0000100302	10 bolt 30	2	2	
7-12	K0071000592	M10 knock bolt 40	4	4	
7-13	LM56G--0705Z2	front stay pipe	1	1	
7-14	LM66G--0705Z2	front stay pipe	0	0	
7-15	K3662000050	engine swtich	1	1	
7-16	K9100000160	handle cover COMP-U.K	1	1	
7-17					
7-18					
7-19	K4201000590	K mark	1	1	
7-20					
7-21	K4021000010	anchor clip 7.5	4	4	
7-22	K1300000140	handle grip (black) 21	2	2	
7-23	K1211260040	clutch lever E126004	1	1	
7-24	K1203521000	throttle lever E352100	1	1	
7-25					
7-26					
7-27					
7-28					
7-29					
7-30					
7-31					
7-32	LM56GA-1901ZL	handle 56E	1	1	
7-33	LM66GA-1901ZL	handle 66E	0	0	
7-34	K4241000010	nylon band 140	3	3	
7-35	K4241000070	urethane tube 7	3	3	

Cat No.	Code No.	Part Name	Qty		Remark
			LM56	LM66	
7-36	K0010100252	10 heat-treated bolt 25	2	2	
7-37					
7-38	K1110117000	throttle wire 1170	1	1	
7-39	LM55GB-0716E0	handle adjuster (R)	1	1	
7-40	K1130137400	clutch wire 1374	1	1	
7-41	K6030050122	5 flat-head pin 12	2	2	
7-42	K0300020122	2 split pin 12	2	2	
7-43	LM55GB-0715E0	handle adjuster (L)	1	1	
7-44	K1120134700	brake wire 1347	1	1	
7-45	LM56G--0708ZL	stand	1	1	
7-46	K0100100002	10 nut	2	2	
7-47	K0000100252	10 bolt 25	2	2	
7-48	K1020000198	2.6 round hook spring 15.584	1	1	
7-49	K0401014001	stop ring S14	1	1	
7-50	LM56GA-0707ZR	rear frame stay	1	0	
7-51	LM66GA-0707ZR	rear frame stay	0	1	
7-52	LM56G--1102Z2	wire mount plate	1	1	
7-53	K0000060152	6 bolt 15	5	5	
7-54	K0200060002	6S washer	5	5	
7-55	K1720000150	brake ASS'Y62	1	1	
7-56	K4019000020	brake cover packing	1	1	
7-57	K1211460010	clutch lever E146001	1	1	
7-58	K100000082D	2.6 compression spring 17.270	1	1	
7-59	K5000080002	8 washer	9	9	
7-60	K0100080002	8 nut	3	3	
7-61	K0200080002	8S washer	9	13	
7-62	K0000080152	8 bolt 15	0	2	
7-63	K0000080202	8 bolt 20	0	2	
7-64	LM66G--0709ZR	reinforcing plate	0	1	
7-65	K0000080302	8 bolt 30	4	4	
7-66	K0000080402	8 bolt 40	4	4	

### 8. Groomer

1

2

3

4

5

※ The number of dethatching blades, collars, adjusting washers, and washers differs according to the models.

	LM56-78	LM66-92	LM56-39-1 (t=1)	LM66-46-1 (t=1)
8-23 (0.5mm)	78	92	0	0
8-22	81	95	81	95
8-24	3~5	4~6	0	0
8-70	0	0	0	0
8-73 (1.0mm)	0	0	39	46

A

B

C

D

E

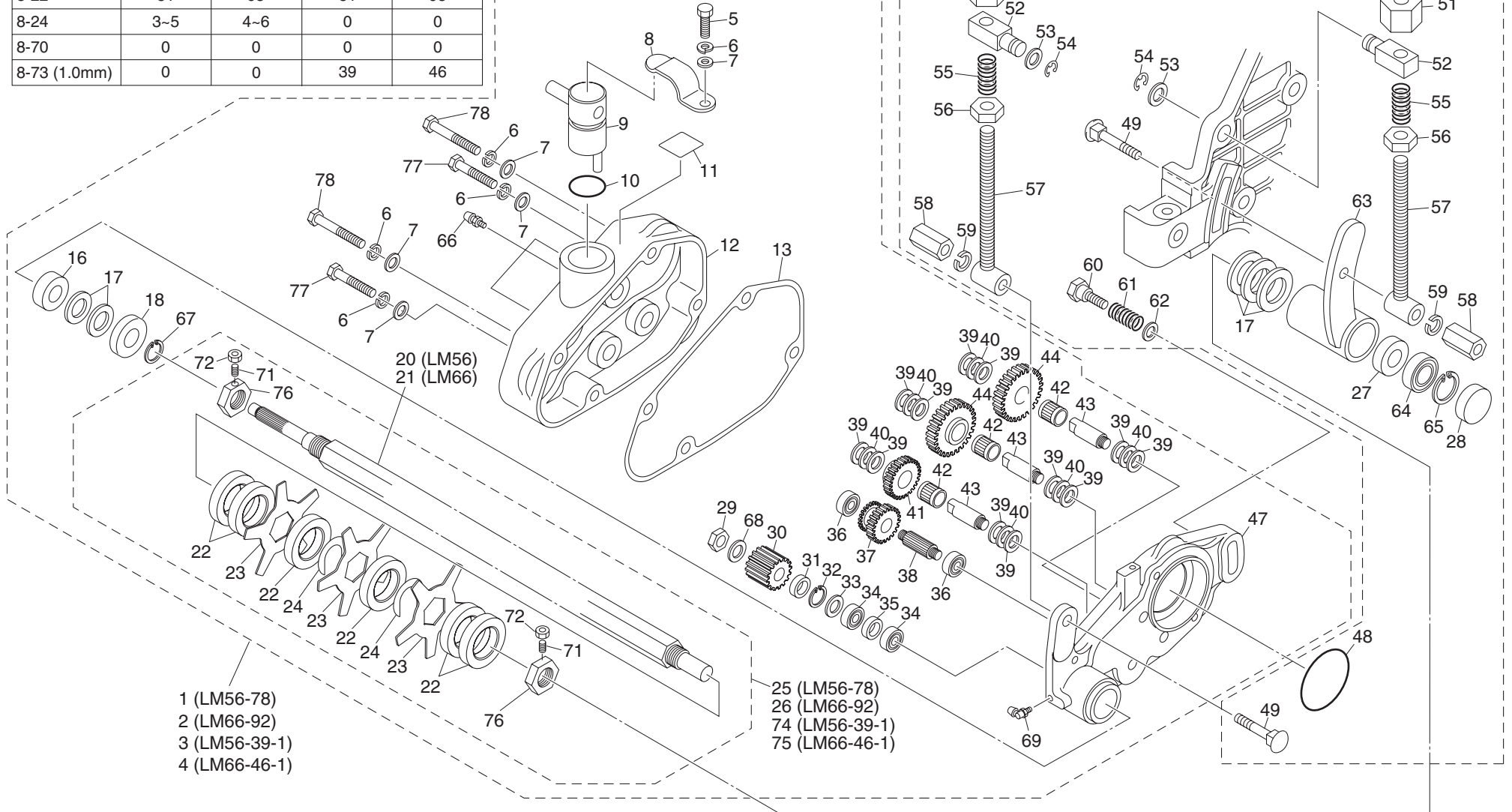

Cat No.	Code No.	Part Name	Qty		Remark
			LM56	LM66	
8-1	LM56G--8001Z0	56 groomer gear 78ASS'Y	1	0	
8-2	LM66G--8001Z0	66 groomer gear 92ASS'Y	0	1	
8-3	LM56G--8801Z0	56 groomer gear 39-1ASS'Y	1	0	
8-4	LM66T--8001Z0	66 groomer gear 46-1ASS'Y	0	1	
8-5	K0000060102	6 bolt 10	1	1	
8-6	K0200060002	6S washer	5	5	
8-7	K5000060002	6 washer	5	5	
8-8	K1090000058	clutch support spring	1	1	
8-9	K7321000148	vertical clutch lever	1	1	
8-10	K0880018000	O-ring P18	1	1	
8-11	K4203001120	groomer operation mark	1	1	
8-12	K690200004R	gearcase cover	1	1	
8-13	LM56G--8002A0	gearcase packing	1	1	
8-14					
8-15					
8-16	K0821522070	oil seal MHSA15227	1	1	
8-17	K5051015280	1C5191P metal washer 1528	5	5	
8-18	K5300000293	dustproof cover	1	1	
8-19	LM56GA-2907Z0	56/66 attachment fitting parts Kit	1	1	
8-20	K6084000118	vertical shaft	1	0	
8-21	LM66G--1211Z8	vertical shaft	0	1	
8-22	K6214000030	19.7AC collar 326.1	81	95	
8-23	K2570000019	thatching blade 63	78	92	
8-24	K5090000673	0.5SPCC adjusting metal washer	5	5	
8-25	LM56G--1219Z0	groomer reel 78COMP	1	1	
8-26	LM66G--1219Z0	grommer reel 92COMP	0	0	
8-27	K0821525070	oil seal MHSA15257	1	1	
8-28	K0890000060	plug 30	1	1	
8-29	K0160000322	10 left-hand thread nut P1	1	1	
8-30	K6180000160	20 vertical gear	1	1	
8-31	K6212001910	12.1STKM collar 176	1	1	
8-32	K0402024001	stop ring R24	1	1	
8-33	K0220160110	16011 wave metal washer	1	1	
8-34	K0611069010	bearing 6901RDC3	2	2	
8-35	K6212001590	12.1STKM collar 1714	1	1	

Cat No.	Code No.	Part Name	Qty		Remark
			LM56	LM66	
8-36	K0608060000	bearing 60002RS	2	2	
8-37	K6180000150	23 clutch gear	1	1	
8-38	K6100000100	clutch shaft	1	1	
8-39	K5051010160	1C5191P metal washer 1016	12	12	
8-40	K5020810160	0.8NBS55 metal washer 1016	6	6	
8-418	K6186000040	18 gear B	1	1	
8-42	K0701013100	needle KT101310EGB2	3	3	
8-43	K6120000310	intermediate shaft	3	3	
8-44	K6186000050	24 gear	2	2	
8-45					
8-46					
8-47	K690100013R	vertical gearcase	1	1	
8-48	K0882045000	O-ring G45	1	1	
8-49	K0025080552	8 rectangular neck round head bolt 55	2	2	
8-50	LM56G--1216Z2	8 special nut B	2	2	
8-51	LM56G--1215Z2	8 special nut A	2	2	
8-52	LM56G--1217Z2	adjuster receiver	2	2	
8-53	K5011013222	1 SPCC metal washer 1322	2	2	
8-54	K0400010002	stop ring E10	2	2	
8-55	K1000000238	1.4 compression spring 13.342	2	2	
8-56	K0100080002	8 nut	2	2	
8-57	LM56G--1218Z2	adjusting screw 108	1	1	
8-58	K0149083202	8-13 high nut 20	2	2	
8-59	K0200080002	8S washer	2	2	
8-60	K6083000143	right case stop bolt	1	1	
8-61	K1000000309	1.6 compression spring 13.720	1	1	
8-62	K5090000250	2C5191P metal washer 8.522	1	1	
8-63	LM56G--1212BR	vertical housing (L)	1	1	
8-64	K0608069020	bearing 69022RS	1	1	
8-65	K0402028001	stop ring R28	1	1	
8-66	K1440000010	grease nipple	3	3	
8-67	K0401015001	stop ring S15	1	1	
8-68	K0213100002	10 metal washer with conical disk spring 1H	1	1	
8-69	K1440000020	C-shaped grease nipple	1	1	
8-70					

# 8. Groomer

1

2

3

4

5

※ The number of dethatching blades, collars, adjusting washers, and washers differs according to the models.

	LM56-78	LM66-92	LM56-39-1 (t=1)	LM66-46-1 (t=1)
8-23 (0.5mm)	78	92	0	0
8-22	81	95	81	95
8-24	3~5	4~6	0	0
8-70	0	0	0	0
8-73 (1.0mm)	0	0	39	46

A

B

C

D

E

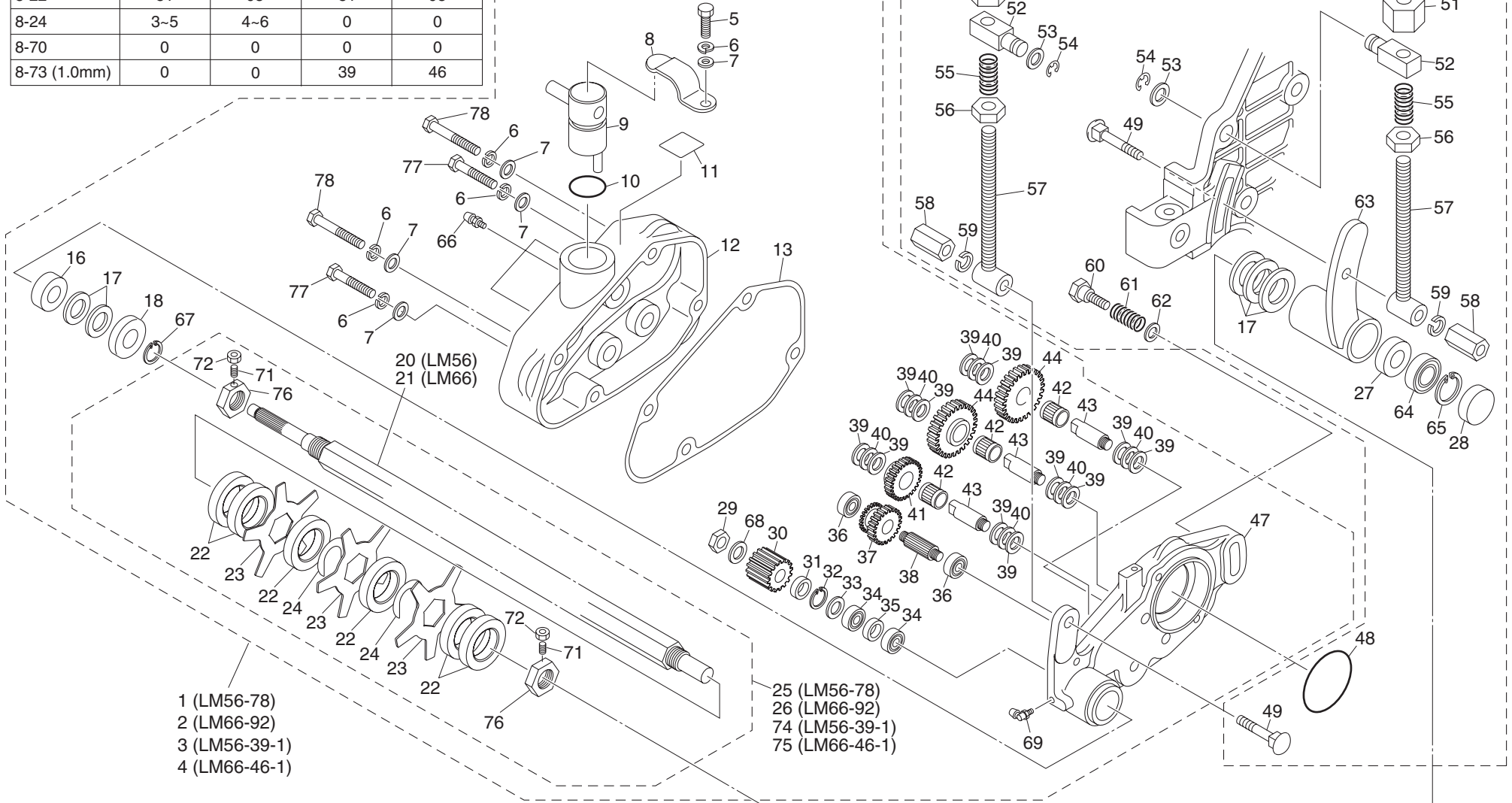

- 1 (LM56-78)
- 2 (LM66-92)
- 3 (LM56-39-1)
- 4 (LM66-46-1)

- 25 (LM56-78)
- 26 (LM66-92)
- 74 (LM56-39-1)
- 75 (LM66-46-1)



Cat No.	Code No.	Part Name	Qty		Remark
			LM56	LM66	
8-71	K0023000041	4 hollow set screw 8	2	2	
8-72	K0100040002	4 nut	2	2	
8-73	K2570000099	thatching blade 63-1	39	46	
8-74	LM56G--2102Z0	groomer reel 39-1COMP	1	0	
8-75	LM66G--2102Z0	groomer reel 46-1COMP	0	1	
8-76	K0160000602	17 special nut with P1M4	2	2	
8-77	K0000060402	6 bolt 40	2	2	
8-78	K0000060502	6 bolt 50	2	2	
		Item 8-23 is 0.5 mm thick Item 8-73 is 1.0 mm thick			

Cat No.	Code No.	Part Name	Qty		Remark
			LM56	LM66	

9. Brush

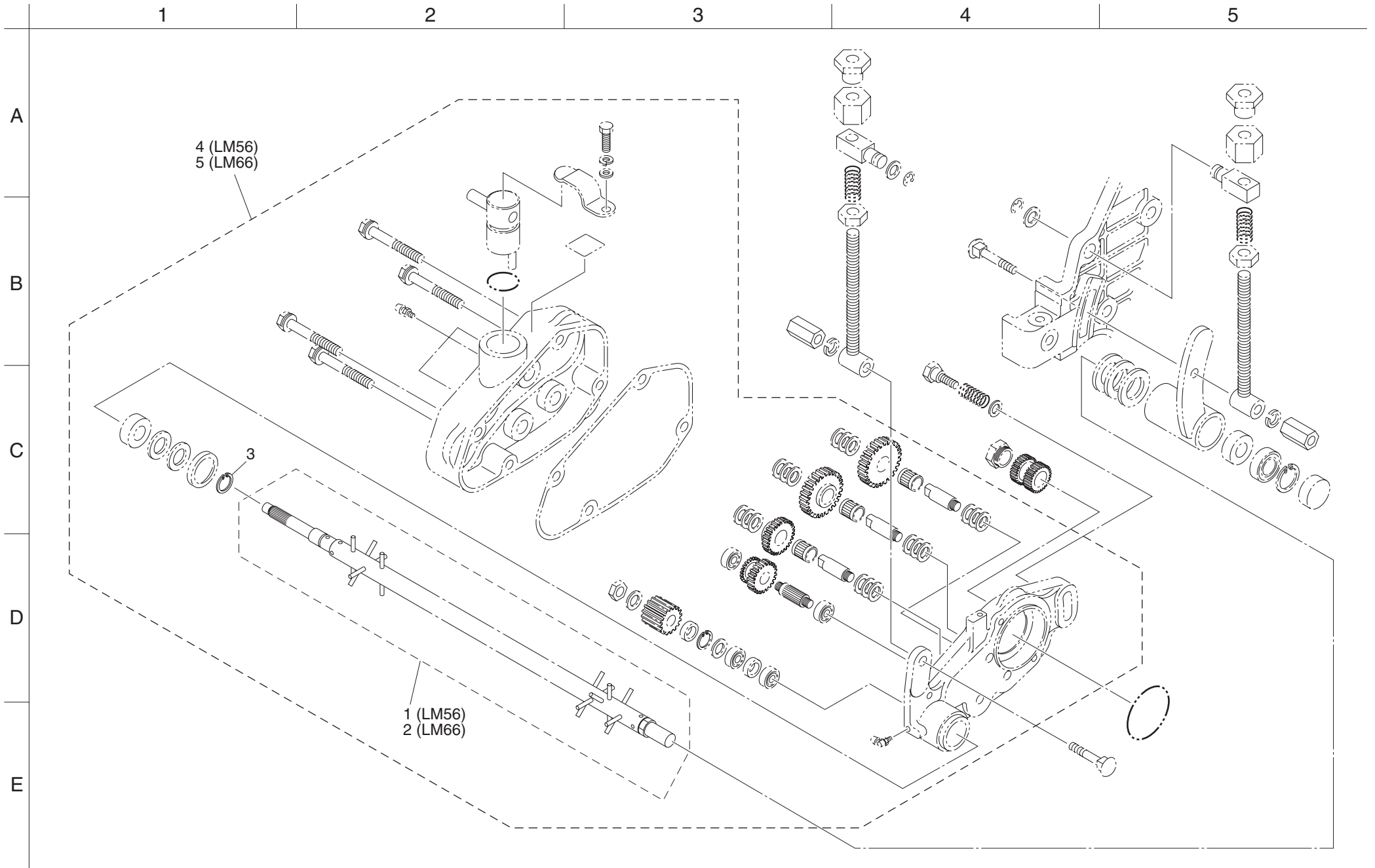

Cat No.	Code No.	Part Name	Qty		Remark
			LM56	LM66	
9-1	K4150000190	brush with shaft ASS'Y	1	0	
9-2	LM66G--1404A0	brush with shaft ASS'Y	0	1	
9-3	K0401015001	stop ring S15	1	1	
9-4	LM56G--8701Z0	56 brush gear case assy	1	0	
9-5	LM66G--8701Z0	66 brush gear case assy	0	1	

Cat No.	Code No.	Part Name	Qty		Remark
			LM56	LM66	

10. Grass catcher/tool

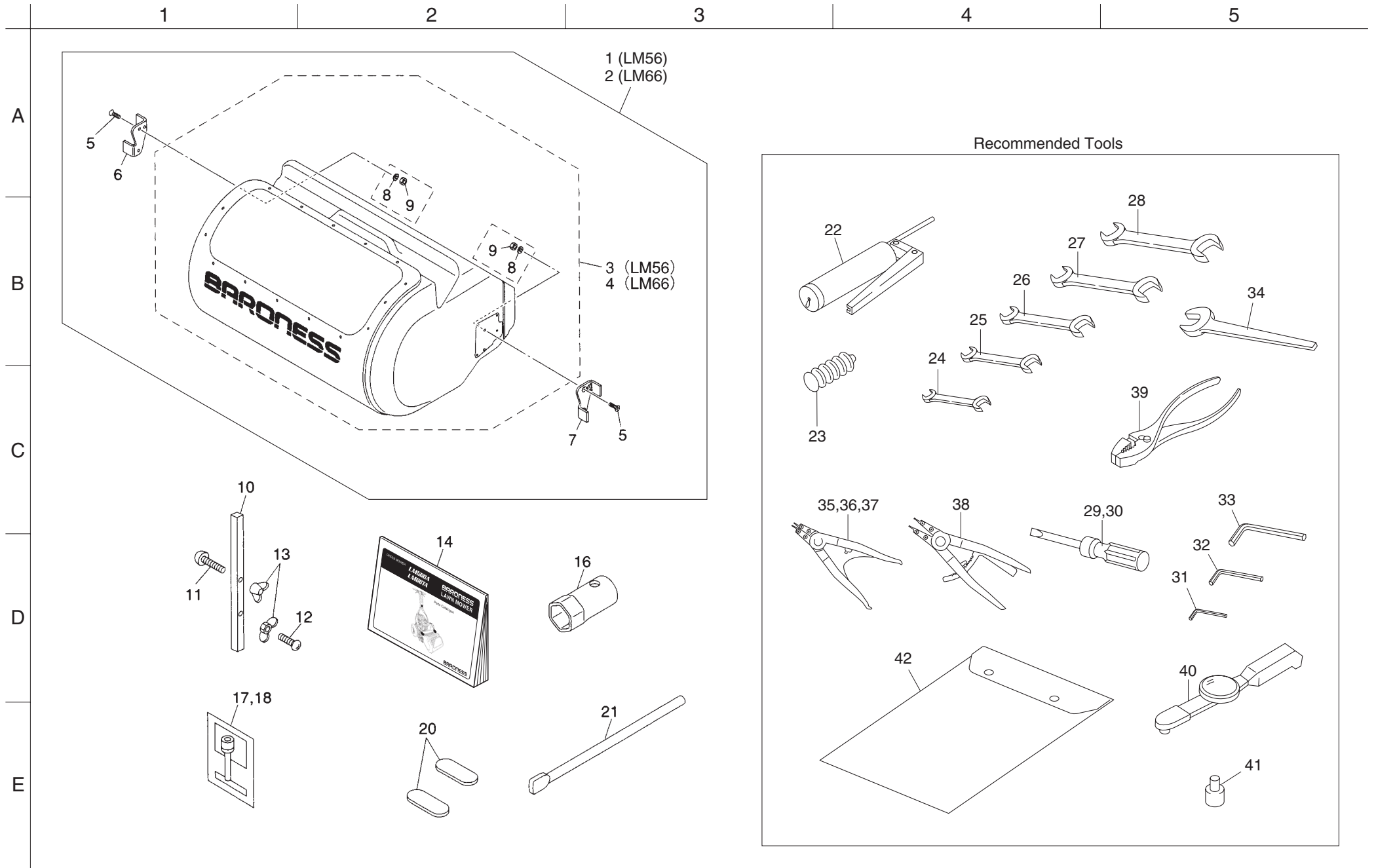



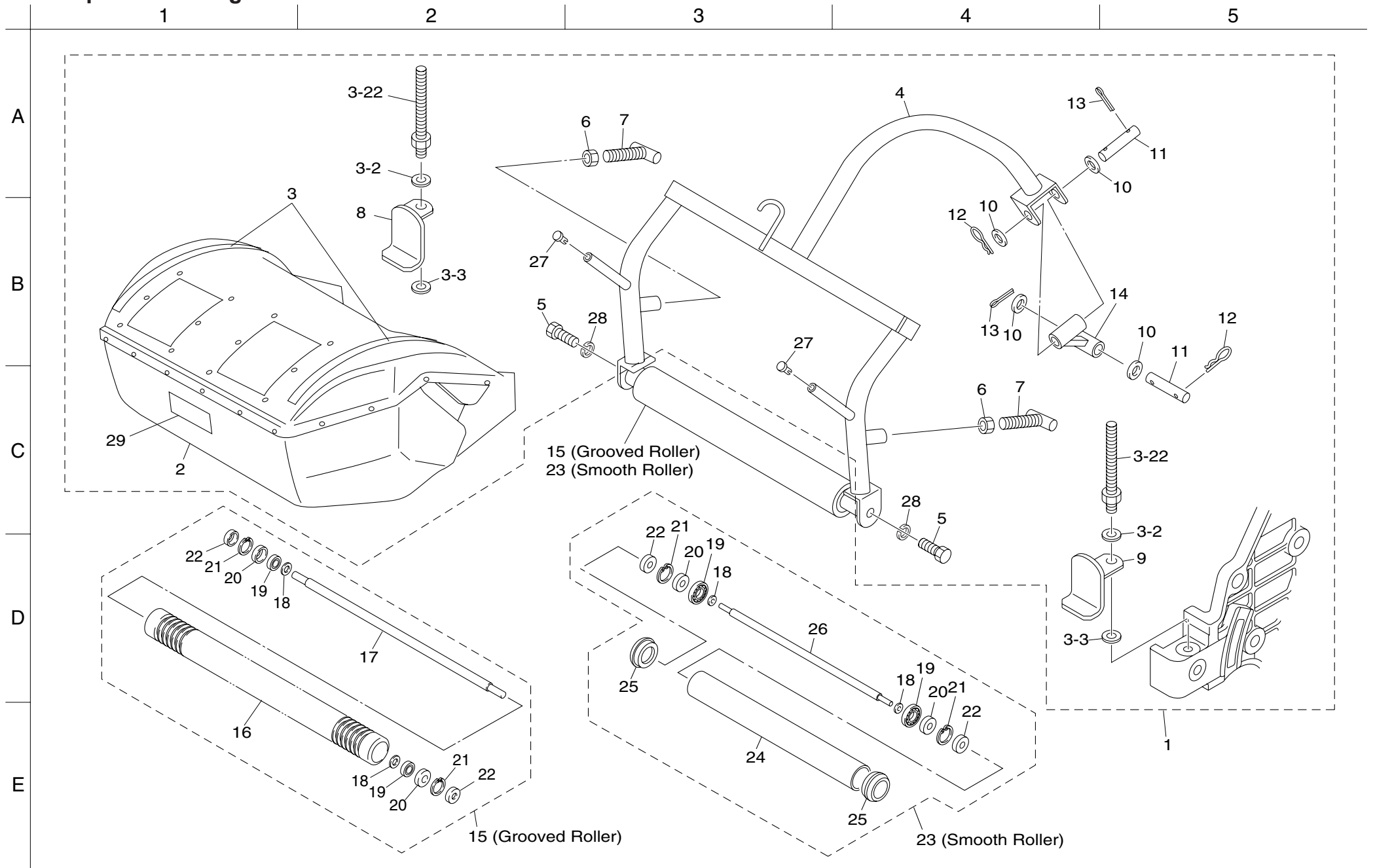

11. Independent arm grass catcher



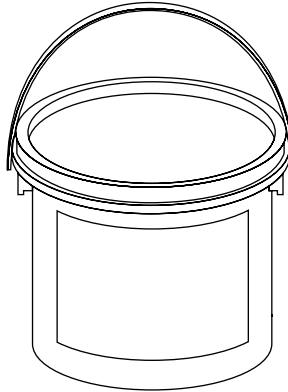
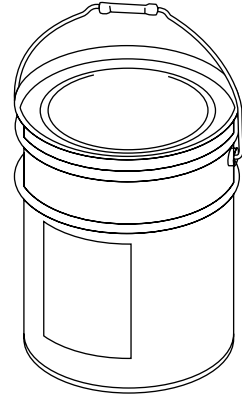

12. Maintenance supplies

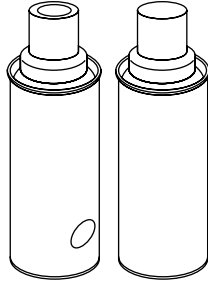
	1	2	3	4	5
A			■ Gel compound		
B					
C			Gel compound #220 1 Can (3.5kg) (6902110) Gel compound #220 1 case (4 Cans) (6902111)		
D	■ Excelite Ep2 grease			■ BARONESS lacquer spray (400 ml)	
E	 18kg Can (2931018000)	 400g tube (K2931000400)		 Wine red (750301) Light gray (750302)	



# MEMO

# MEMO

# MEMO



**KYOISHA CO., LTD.**

Head Office 1-26, Miyuki-cho, Toyokawa,  
Aichi-Pref. 442-8530 Japan.

**BRONSS**  
Turf Care Machinery  
Tel: (0533) 84-1390  
Fax: (0533) 89-3623